

DATA SHEET

BFQ18A NPN 4 GHz wideband transistor

Product specification
File under Discrete Semiconductors, SC14

September 1995

NPN 4 GHz wideband transistor

BFQ18A

DESCRIPTION

NPN transistor in a plastic SOT89 envelope intended for application in thick and thin-film circuits. It is primarily intended for MATV purposes.

PINNING

PIN	DESCRIPTION
Code: FF	
1	emitter
2	collector
3	base

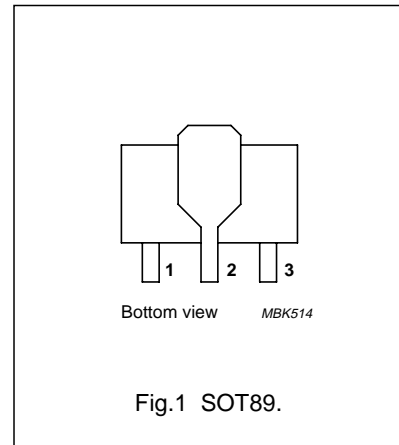

QUICK REFERENCE DATA

SYMBOL	PARAMETER	CONDITIONS	TYP.	MAX.	UNIT
V_{CBO}	collector-base voltage	open emitter	–	25	V
V_{CEO}	collector-emitter voltage	open base	–	18	V
I_C	DC collector current		–	150	mA
P_{tot}	total power dissipation	up to $T_s = 155\text{ °C}$ (note 1)	–	1	W
f_T	transition frequency	$I_C = 100\text{ mA}$; $V_{CE} = 10\text{ V}$; $f = 500\text{ MHz}$; $T_j = 25\text{ °C}$	4	–	GHz
C_{re}	feedback capacitance	$I_C = 0$; $V_{CE} = 10\text{ V}$; $f = 10.7\text{ MHz}$	1.2	–	pF
d_{im}	intermodulation distortion	$I_C = 80\text{ mA}$; $V_{CE} = 10\text{ V}$; $R_L = 75\text{ }\Omega$; $V_o = 700\text{ mV}$; measured at $f_{(p+q-r)} = 793.25\text{ MHz}$	–	–60	dB

LIMITING VALUES

In accordance with the Absolute Maximum System (IEC 134).

SYMBOL	PARAMETER	CONDITIONS	MIN.	MAX.	UNIT
V_{CBO}	collector-base voltage	open emitter	–	25	V
V_{CEO}	collector-emitter voltage	open base	–	18	V
V_{EBO}	emitter-base voltage	open collector	–	2	V
I_C	DC collector current		–	150	mA
P_{tot}	total power dissipation	up to $T_s = 155\text{ °C}$ (note 1)	–	1	W
T_{stg}	storage temperature		–65	150	°C
T_j	junction temperature		–	175	°C

Note

- T_s is the temperature at the soldering point of the collector tab.

NPN 4 GHz wideband transistor

BFQ18A

THERMAL RESISTANCE

SYMBOL	PARAMETER	CONDITIONS	THERMAL RESISTANCE
$R_{th\ j-s}$	thermal resistance from junction to soldering point	up to $T_s = 155\text{ °C}$ (note 1)	20 K/W

Note

- T_s is the temperature at the soldering point of the collector tab.

CHARACTERISTICS

$T_j = 25\text{ °C}$ unless otherwise specified.

SYMBOL	PARAMETER	CONDITIONS	MIN.	TYP.	UNIT
h_{FE}	DC current gain	$I_C = 100\text{ mA}$; $V_{CE} = 10\text{ V}$	25	–	
C_c	collector capacitance	$I_E = i_e = 0$; $V_{CB} = 10\text{ V}$; $f = 1\text{ MHz}$	–	2	pF
C_e	emitter capacitance	$I_C = i_c = 0$; $V_{EB} = 0.5\text{ V}$; $f = 1\text{ MHz}$	–	11	pF
C_{re}	feedback capacitance	$I_C = 0$; $V_{CE} = 10\text{ V}$; $f = 10.7\text{ MHz}$	–	1.2	pF
f_T	transition frequency	$I_C = 100\text{ mA}$; $V_{CE} = 10\text{ V}$; $f = 500\text{ MHz}$	–	4	GHz
d_{im}	intermodulation distortion (see Fig.2)	note 1	–	–60	dB

Note

- $I_C = 80\text{ mA}$; $V_{CE} = 10\text{ V}$; $R_L = 75\ \Omega$;
 $V_p = V_o = 700\text{ mV}$; $f_p = 795.25\text{ MHz}$;
 $V_q = V_o - 6\text{ dB}$; $f_q = 803.25\text{ MHz}$;
 $V_r = V_o - 6\text{ dB}$; $f_r = 805.25\text{ MHz}$;
measured at $f_{(p+q-r)} = 793.25\text{ MHz}$.

NPN 4 GHz wideband transistor

BFQ18A

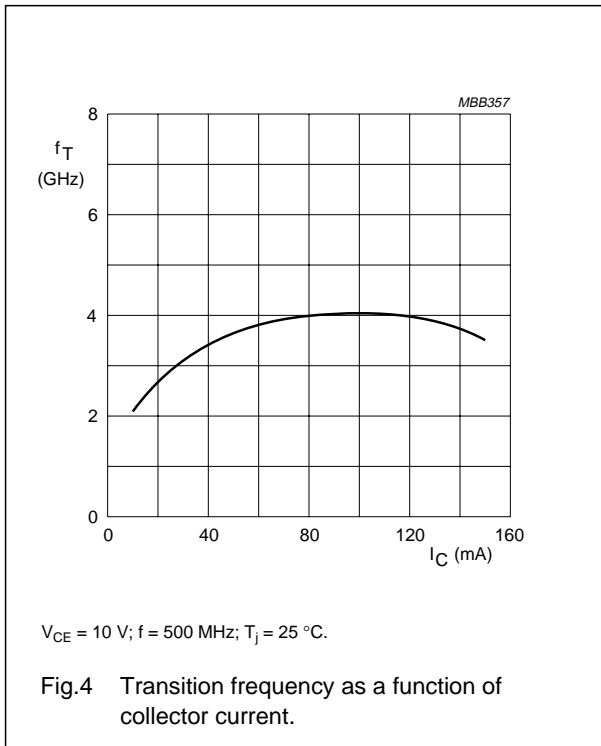
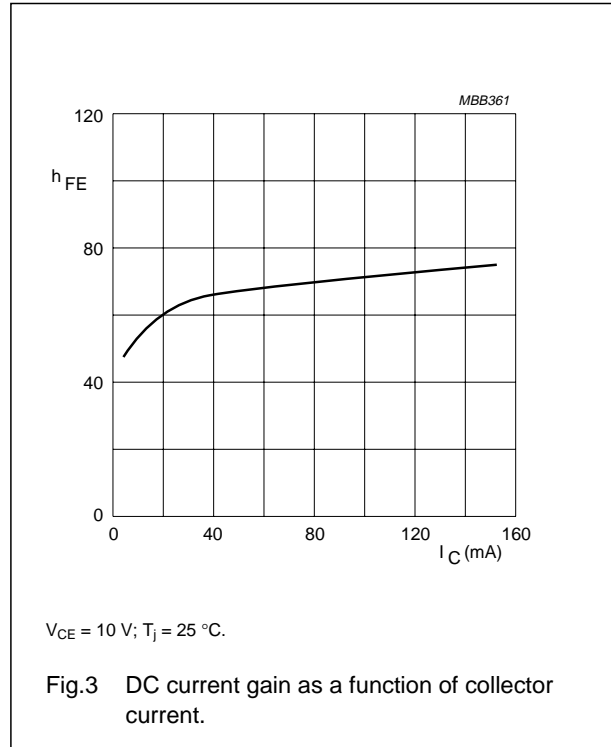
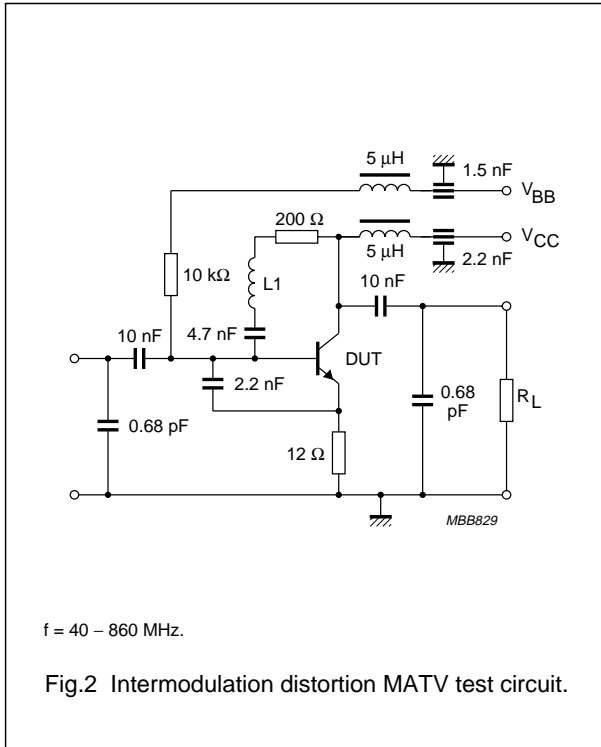

NPN 4 GHz wideband transistor

BFQ18A

PACKAGE OUTLINE

Plastic surface mounted package; collector pad for good heat transfer; 3 leads

SOT89

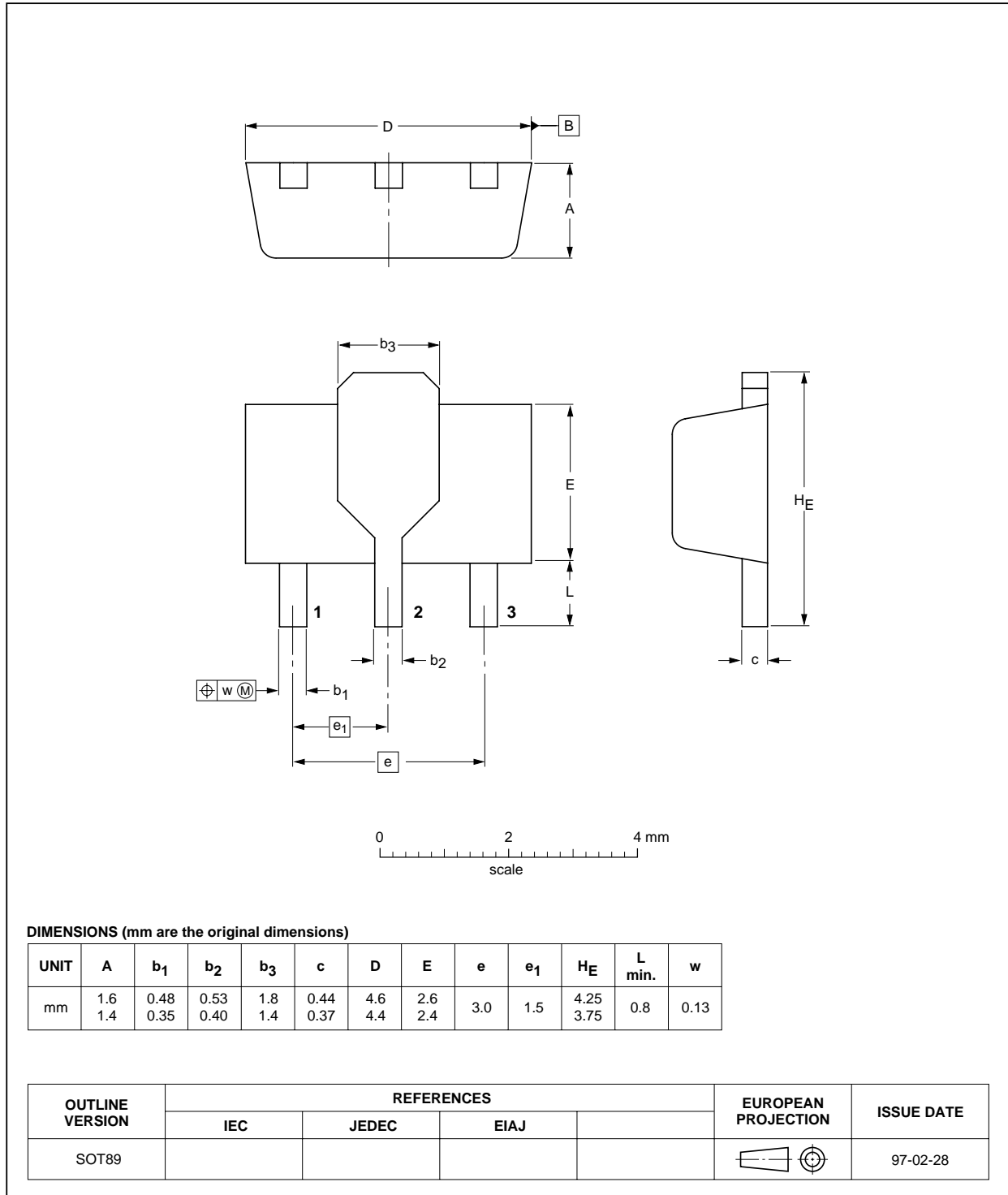

NPN 4 GHz wideband transistor

BFQ18A

DEFINITIONS

Data Sheet Status	
Objective specification	This data sheet contains target or goal specifications for product development.
Preliminary specification	This data sheet contains preliminary data; supplementary data may be published later.
Product specification	This data sheet contains final product specifications.
Limiting values	
Limiting values given are in accordance with the Absolute Maximum Rating System (IEC 134). Stress above one or more of the limiting values may cause permanent damage to the device. These are stress ratings only and operation of the device at these or at any other conditions above those given in the Characteristics sections of the specification is not implied. Exposure to limiting values for extended periods may affect device reliability.	
Application information	
Where application information is given, it is advisory and does not form part of the specification.	

LIFE SUPPORT APPLICATIONS

These products are not designed for use in life support appliances, devices, or systems where malfunction of these products can reasonably be expected to result in personal injury. Philips customers using or selling these products for use in such applications do so at their own risk and agree to fully indemnify Philips for any damages resulting from such improper use or sale.