

Mobile DiskOnChip® Plus 16/32MByte

1.8V I/O Flash Disk, Protection and Security-Enabling Features



Highlights

Mobile DiskOnChip Plus 16/32MByte (128/256Mbit) is one of the industry's most efficient storage solutions, with the fastest write rates, the smallest size and lowest power consumption.

Additionally, it offers advanced data protection and security-enabling features. Based on a monolithic (dual-die) chip that utilizes Toshiba's 0.16 μ NAND technology, Mobile DiskOnChip Plus attains levels of reliability that surpass competing products.

These characteristics make Mobile DiskOnChip Plus ideal for meeting the growing demand for secure and reliable data storage in mobile multimedia devices, such as mobile phones and Personal Digital Assistants (PDAs).

Mobile DiskOnChip Plus 16/32MByte features:

- Exceptional read, write and erase performance
- Advanced protection and security-enabling features for data and code
- Low voltage:
 - Core – 3V
 - I/O – 1.8V/3V auto-detect
- Small form factor: 69-ball 9x12 mm Fine-Pitch Ball Grid Array (FBGA)
- NAND-based flash technology that enables high density and small die size
- Proprietary TrueFFS® technology for full hard disk emulation, high data reliability and maximum flash lifetime
- Single-die chip: 16MByte
Dual -die chip: 32MByte with device cascade options for up to 64MByte (512Mbit) capacity
- Programmable Boot Block with eXecute In Place (XIP) functionality using 16-bit access, with download support for more code
- Configurable for 8/16/32-bit bus interface
- Data integrity with Reed-Solomon-based Error Detection Code/Error Correction Code (EDC/ECC)
- Deep Power-Down mode for reduced power consumption
- Support for all major mobile OSs, including: Symbian OS, Windows CE, Smartphone 2002/3, Pocket PC, Nucleus, OSE, and Linux



Performance

- Burst read/write: 13.3 MB/sec
- Sustained read: 1.7 MB/sec
- Sustained write: 0.86 MB/sec

Protection and Security Enabling Features

- 16-byte Unique Identification (UID) number
- 6KByte user-configurable One Time Programmable (OTP) area
- Two configurable write-protected and read-protected partitions for data and boot code
- Hardware data and code protection:
 - Protection key and LOCK# signal
 - Sticky Lock option for lock of boot partition
 - Protected Bad Block Table

Boot Capability

- Programmable Boot Block with XIP functionality to replace boot ROM:
 - 1KB for 16MB devices
 - 2KB for 32MB devices
- Download Engine (DE) for automatic download of boot code from Programmable Boot Block
- Boot capabilities:
 - CPU initialization
 - Platform initialization
 - OS boot
- Asynchronous Boot mode to boot CPUs that wake up in burst mode

The following abbreviations are used in this document: MB for MByte, Mb for Mbit.

Reliability

- On-the-fly Reed-Solomon Error Detection Code/Error Correction Code (EDC/ECC)
- Guaranteed data integrity, even after power failure
- Transparent bad-block management
- Dynamic and static wear-leveling

Hardware Compatibility

- Configurable interface: simple SRAM-like or multiplexed A/D interface
- Compatible with all major CPUs, including:
 - ARM-based CPUs
 - Texas Instruments OMAP
 - Intel StrongARM/XScale
 - AMD Alchemy
 - Motorola PowerPC™ MPC8xx
 - Motorola DragonBall MX1
 - Philips PR31700
 - Hitachi SuperH™ SH-x
 - NEC VR Series
- 8-bit, 16-bit and 32-bit bus architecture support

TrueFFS Software

- Full hard-disk read/write emulation for transparent file system management
- Identical software for all DiskOnChip capacities
- Patented methods to extend flash lifetime, including:
 - Dynamic virtual mapping
 - Dynamic and static wear-leveling

- Support for all major OS environments, including:
 - Symbian OS
 - Windows CE
 - Pocket PC
 - Smartphone
 - OSE
 - ATI Nucleus
 - Linux
- Support for OS-less environments
- 8KByte memory window

Power Requirements

- Operating voltage
 - Core: 2.5 to 3.6V
 - I/O (auto-detect): 1.65 - 1.95V or 2.5V - 3.6V
- Current
 - Active: 25 mA (Typ.)
 - Deep Power-Down (Typ.): 10 μ A (16MB) 20 μ A (32MB)

Capacities

- 16MB (128Mb) with device-cascading option for up to 64MB (512Mb)
- 32MB (256Mb) with device cascading option for up to 64MB (512Mb)

Packaging

- 69-ball FBGA: 9 x 12 x 1.4 mm (max)

Table of Contents

1. Introduction	7
2. Product Overview	8
2.1 Product Description	8
2.2 Standard Interface	9
2.2.1 Ball Diagram	9
2.2.2 System Interface	10
2.2.3 Signal Description	11
2.3 Multiplexed Interface	13
2.3.1 Ball Diagram	13
2.3.2 System Interface	14
2.3.3 Signal Description	15
3. Theory of Operation	17
3.1 Overview	17
3.2 System Interface	18
3.3 Configuration Interface	18
3.4 Protection and Security-Enabling Features	18
3.4.1 Read/Write Protection	18
3.4.2 Unique Identification (UID) Number	19
3.4.3 One-Time Programmable (OTP) Area	19
3.5 Programmable Boot Block with eXecute In Place (XIP) Functionality	19
3.6 Download Engine (DE)	19
3.7 Error Detection Code/Error Correction Code (EDC/ECC)	20
3.8 Data Pipeline	20
3.9 Control & Status	20
3.10 Flash Architecture	20
4. Hardware Protection	22
4.1 Method of Operation	22
4.2 Low-Level Structure of the Protected Area	23
5. Modes of Operation	24
5.1 Normal Mode	25
5.2 Reset Mode	25
5.3 Deep Power-Down Mode	25
6. TrueFFS Technology	26
6.1 General Description	26
6.1.1 Built-In Operating System Support	26
6.1.2 TrueFFS Software Development Kit (SDK)	27
6.1.3 File Management	27
6.1.4 Bad-Block Management	27
6.1.5 Wear-Leveling	27
6.1.6 Power Failure Management	28
6.1.7 Error Detection/Correction	28
6.1.8 Special Features through I/O Control (IOCTL) Mechanism	28

6.1.9	Compatibility.....	28
6.2	8KB Memory Window in Mobile DiskOnChip Plus 16MB.....	29
6.3	8KB Memory Window for Mobile DiskOnChip Plus 32MB	30
7.	Register Descriptions	31
7.1	Definition of Terms.....	31
7.2	Reset Values	31
7.3	Chip Identification (ID) Register.....	31
7.4	No Operation (NOP) Register.....	32
7.5	Test Register	32
7.6	DiskOnChip Control Register/Control Confirmation Register.....	33
7.7	Device ID Select Register.....	34
7.8	Configuration Register	34
7.9	Output Control Register.....	35
7.10	Interrupt Control.....	35
7.11	Toggle Bit Register	36
8.	Bootng from Mobile DiskOnChip Plus	37
8.1	Introduction.....	37
8.2	Boot Procedure in PC-Compatible Platforms	37
8.3	Boot Replacement	38
8.3.1	PC Architectures	38
8.3.2	Non-PC Architectures	38
8.3.3	Using Mobile DiskOnChip Plus in Asynchronous Boot Mode.....	39
9.	Design Considerations	40
9.1	Design Environment	40
9.2	System Interface.....	41
9.2.1	Standard Interface.....	41
9.2.2	Multiplexed Interface	42
9.3	Connecting Signals.....	42
9.3.1	Standard Interface.....	42
9.3.2	Multiplexed Interface	43
9.4	Implementing the Interrupt Mechanism	43
9.4.1	Hardware Configuration	43
9.4.2	Software Configuration	43
9.5	Platform-Specific Issues	44
9.5.1	Wait State.....	44
9.5.2	Big and Little Endian Systems	44
9.5.3	Busy Signal	44
9.5.4	Working with 8/16/32-Bit Systems with a Standard Interface	44
9.6	Device Cascading.....	46
9.6.1	Standard Interface.....	46
9.6.2	Multiplexed Interface	46
9.6.3	Memory Map in a Cascaded Configuration	47
10.	Product Specifications	48

10.1 Environmental Specifications	48
10.1.1 Operating Temperature Ranges	48
10.1.2 Thermal Characteristics	48
10.1.3 Humidity	48
10.1.4 Endurance	48
10.2 Disk Capacity	48
10.3 Electrical Specifications	49
10.3.1 Absolute Maximum Ratings	49
10.3.2 Capacitance	49
10.3.3 DC Electrical Characteristics Over Operating Range	50
10.3.4 AC Operating Conditions	52
10.4 Timing Specifications	53
10.4.1 Read Cycle Timing Standard Interface	53
10.4.2 Write Cycle Timing Standard Interface	56
10.4.3 Read Cycle Timing Multiplexed Interface	58
10.4.4 Write Cycle Timing Multiplexed Interface	60
10.4.5 Power-Up Timing	62
10.4.6 Interrupt Timing	63
10.5 Mechanical Dimensions	64
11. Ordering Information.....	65

Revision History

Revision	Date	Description	Reference
1.7	February 2003	ID[0:1], AVD# and VCCQ - description detailed Ordering info table updated to reflect Pb-free ordering info	Section 2.2.3 Section 11

1. Introduction

This data sheet includes the following sections:

- Section 1:** Overview of data sheet contents
- Section 2:** Product overview, including a brief product description, pin and ball diagrams and signal descriptions
- Section 3:** Theory of operation for the major building blocks
- Section 4:** Hardware Protection mechanism
- Section 5:** Modes of operation
- Section 6:** TrueFFS technology, including power failure management and 8Kbyte memory window
- Section 7:** Register description
- Section 8:** Using Mobile DiskOnChip Plus as a boot device
- Section 9:** Hardware and software design considerations
- Section 10:** Environmental, electrical, timing and product specifications
- Section 11:** Information on ordering Mobile DiskOnChip Plus
- Appendix A:** Sample code for verifying Mobile DiskOnChip Plus operation

To contact M-Systems' worldwide offices for general information and technical support, please see the listing on the back cover, or visit M-Systems' website (www.m-sys.com).

2. Product Overview

2.1 Product Description

Mobile DiskOnChip Plus 16/32MB is a member of M-Systems' DiskOnChip product series. It is based on a single die (16MB) or dual die (32MB) with an embedded flash controller and flash memory, providing a complete, easily integrated flash disk for highly reliable data storage. Mobile DiskOnChip Plus also offers advanced features for hardware-protected data and code and security-enabling features for both data and code storage. With superior read and write performance, small size and low power consumption, it is optimized for the high-end handset, multimedia handset and PDA markets. These markets require fast read and write rates, minimum weight and space, and low power consumption to support the large and growing pool of data-rich applications.

Mobile DiskOnChip Plus protection and security features offer unique benefits. Two write- and read-protected partitions, with both software- and hardware-based protection, can be configured independently for maximum design flexibility. The 16-byte Unique ID (UID) identifies each flash device, used with security and authentication applications, eliminating the need for a separate ID device (i.e. EEPROM) on the motherboard. The user-configurable One Time Programmable (OTP) area, written to once and then locked to prevent data and code from being altered, is ideal for storing customer and product-specific information. In addition, the Bad Block Table is hardware protected, ensuring that it will not be damaged or accidentally changed to ensure maximum reliability.

Mobile DiskOnChip Plus devices have a simple SRAM-like interface, for easy integration. It can also be configured to work with a multiplexed interface. Multiplexing data and address lines can save board space, reduce RF noise effects and more.

Mobile DiskOnChip Plus is based on Toshiba's cutting-edge 0.16 μ NAND flash technology. This technology enables Mobile DiskOnChip Plus to provide unmatched physical and performance-related benefits. It has the highest flash density in the smallest die size available on the market, for the best cost structure and the smallest real estate. Mobile DiskOnChip Plus devices use 8-bit internal flash access, featuring unrivaled write and read performance.

Mobile DiskOnChip Plus is a cost-effective solution for code storage as well as data storage. A Programmable Boot Block with eXecute In Place (XIP) functionality can store boot code, replacing the boot ROM to function as the only non-volatile memory on board. The Programmable Boot Block is 1KB for 16MB devices, and 2KB for 32MB devices. This reduces hardware expenditures and board real estate. M-Systems' Download Engine (DE) is an automatic bootstrap mechanism that expands the functionality of the Programmable Boot Block to enable CPU and platform initialization directly from Mobile DiskOnChip Plus.

M-Systems' patented TrueFFS software technology fully emulates a hard disk to manage the files stored on Mobile DiskOnChip Plus. This transparent file system management enables read/write operations that are identical to a standard, sector-based hard disk. In addition, TrueFFS employs various patented methods, such as dynamic virtual mapping, dynamic and static wear-leveling, and automatic bad-block management to ensure high data reliability and to maximize flash lifetime. TrueFFS binary drivers are available for a wide range of popular OSs, including Symbian OS, Pocket PC, Smartphone, Windows CE/.NET, OSE, Nucleus, and Linux. Customers developing for target platforms not supported by TrueFFS binary drivers can use the *TrueFFS Software Development Kit (SDK)* developer guide. For customized boot solutions, M-Systems provides the *DiskOnChip Boot Software Development Kit (BDK)* developer guide.

Mobile DiskOnChip Plus is designed for compatibility and easy scalability. All capacities of Mobile DiskOnChip Plus have the same ballout and are interchangeable. Greater capacities may easily be obtained by cascading up to four 16MB devices or two 32MB devices with no additional glue logic. This upgrade path provides a flash disk of up to 64MB (512Mb), while remaining totally transparent to the file system and user.

2.2 Standard Interface

2.2.1 Ball Diagram

See Figure 1 for the Mobile DiskOnChip Plus standard interface FBGA ball diagram. To ensure proper device functionality, balls marked RSRVD are reserved for future use and should not be connected.

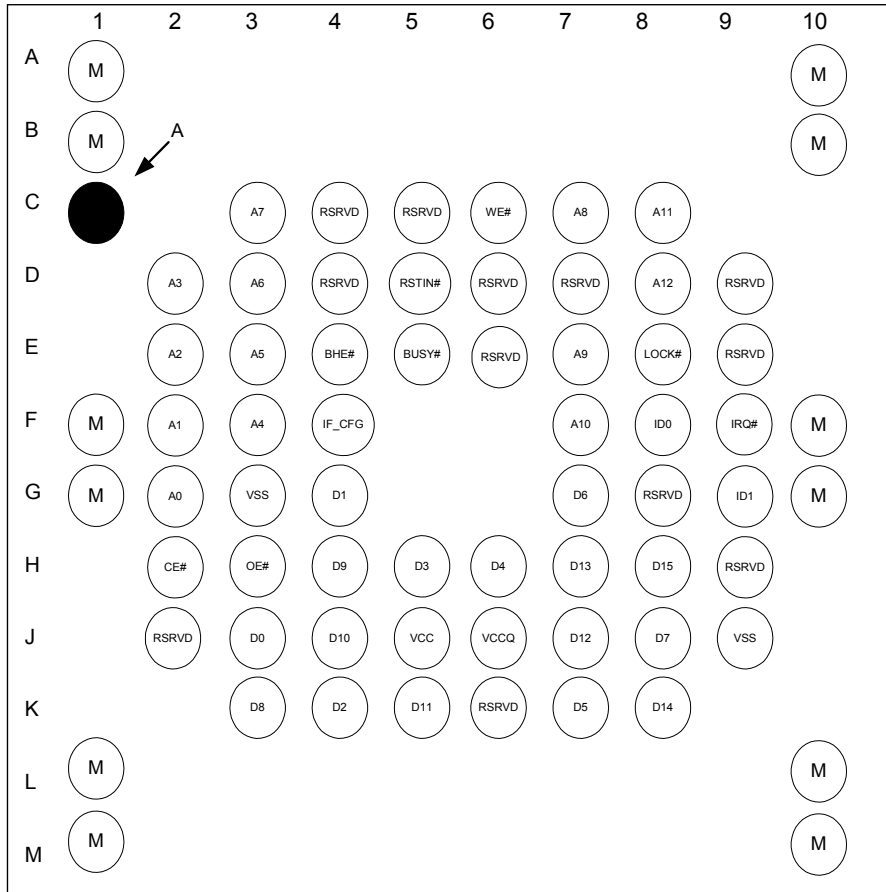

Figure 1: Standard Interface FBGA Ball Diagram (Top View)

2.2.2 System Interface

See Figure 2 for a simplified I/O diagram for a standard interface.

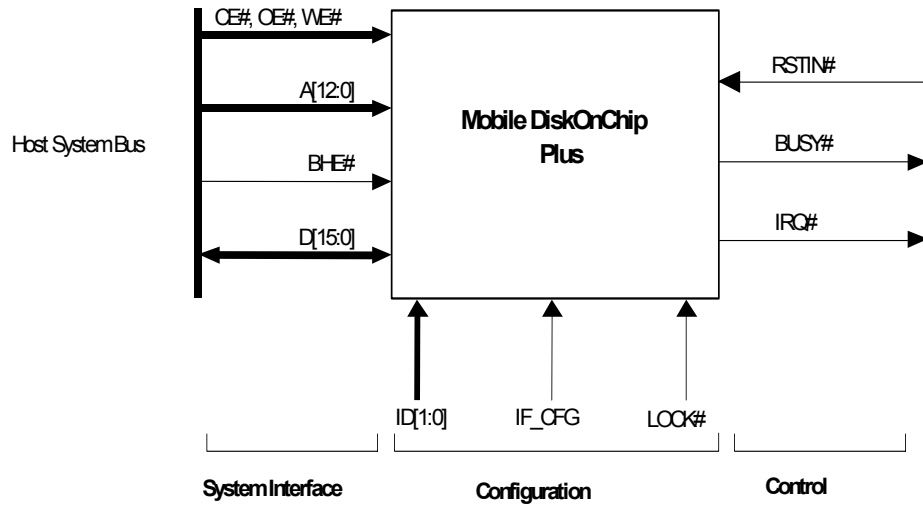

Figure 2: Standard Interface Simplified I/O Diagram

2.2.3 Signal Description

The ball designations are listed in the signal descriptions, presented in logic groups, in Table 1.

Table 1: Standard Interface Signal Descriptions

Signal	Ball No.	Input Type	Description	Signal Type
System Interface				
A[12:11] A[10:8] A[7:4] A[3:0]	D8, C8 F7, E7, C7 C3, D3, E3, F3 D2, E2, F2, G2	ST	Address bus.	Input
BHE#	E4	ST, R8	Byte High Enable, active low. When low, data transaction on D[15:8] is enabled. Not used and may be left floating when IF_CFG is set to 0 (8-bit mode).	Input
CE#	H2	ST, R	Chip Enable, active low.	Input
D[7:0]	J8, G7, K7, H6, H5, K4, G4, J3	IN	Data bus, low byte.	Input/ Output
D[15:8]	H8, K8, H7, J7, K5, J4, H4, K3	IN, R8	Data bus, high byte. Not used and may be left floating when IF_CFG is set to 0 (8-bit mode).	Input/ Output
OE#	H3	ST	Output Enable, active low	Input
WE#	C6	ST	Write Enable, active low	Input
Configuration				
ID[1:0]	G9, F8	ST	Identification. For Mobile DiskOnChip 16MB, up to four chips can be cascaded in the same memory window, according to the following assignment: Chip 1 = ID1, ID0 = VSS, VSS (0,0); required for single chip Chip 2 = ID1, ID0 = VSS, VCC (0,1) Chip 3 = ID1, ID0 = VCC, VSS (1,0) Chip 4 = ID1, ID0 = VCC, VCC (1,1) For Mobile DiskOnChip 32MB, up to two chips can be cascaded in the same memory window, according to the following assignment: Chip 1 : ID1=VSS, ID0 = VSS ;required for single chip Chip 2 : ID1=VSS, ID0 = VCC	Input
IF_CFG	F4	ST	Interface Configuration, 1 for 16-bit interface mode, 0 for 8-bit interface mode.	Input
LOCK#	E8	ST	Lock, active low. When active, provides full hardware data protection of selected partitions.	Input
Control				
BUSY#	E5	OD	Busy, active low, open drain. Indicates that DiskOnChip is initializing and should not be accessed. A 10 K Ω pull-up resistor is required even if the ball is not used.	Output
IRQ#	F9	-	Interrupt Request. Requires a 10 K Ω pull-up resistor.	Output
RSTIN#	D5	ST	Reset, active low.	Input
Power				
VCCQ	J6		I/O power supply. Sets the logic '1' voltage level range of I/O balls/pins. VCCQ may be either 2.5V to 3.6V or 1.65V to 2.0V. Requires a 10 nF and 0.1 μ F capacitor.	Supply

Signal	Ball No.	Input Type	Description	Signal Type
VCC	J5	-	Device supply. Requires a 10 nF and 0.1 μ F capacitor.	Supply
VSS	G3, J9	-	Ground. All VSS balls must be connected.	Supply
Reserved				
RSRVD	K6	-	Reserved signal that is not connected internally. Note: Future DiskOnChip devices will use this pin as a clock input. To be forward compatible, this pin can already be connected to the system CLK or to VCC when the clock input feature is not required.	
	Other. See Figure 1	-	All reserved signals are not connected internally and must be left floating to guarantee forward compatibility with future products. They should not be connected to arbitrary signals.	
Mechanical				
-	M	-	Mechanical. These balls are for mechanical placement, and are not connected internally.	
-	A	-	Alignment. This ball is for device alignment, and is not connected internally.	

The following abbreviations are used:

IN	Standard (non-Schmidt) input
ST	Schmidt Trigger input
OD	Open drain
R8	Nominal 22 K Ω pull-up resistor, enabled only for 8-bit interface mode (IF_CFG input is 0)
R	3.7 M Ω nominal pull-up resistor

Note: For forward compatibility with future DiskOnChip 7x10 FBGA products, additional pads are required. Please refer to application note AP-DOC-067, *Preparing Your PCB Footprint for the DiskOnChip BGA Migration Path*, for detailed information.

2.3 Multiplexed Interface

2.3.1 Ball Diagram

See Figure 3 for the Mobile DiskOnChip Plus multiplexed interface FBGA ball diagram. To ensure proper device functionality, balls marked RSRVD are reserved for future use and should not be connected.

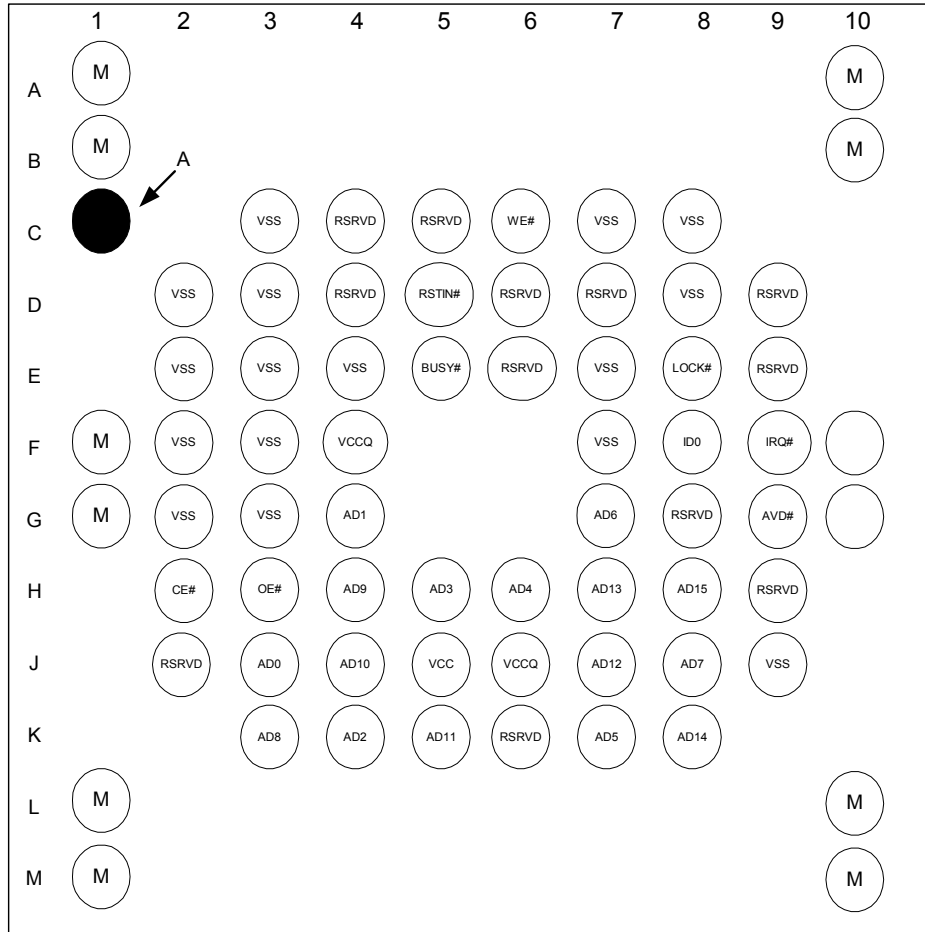

Figure 3: Multiplexed Interface Mobile DiskOnChip Plus 16MB FBGA Ball Diagram (Top View)

2.3.2 System Interface

See Figure 4 for a simplified I/O diagram.

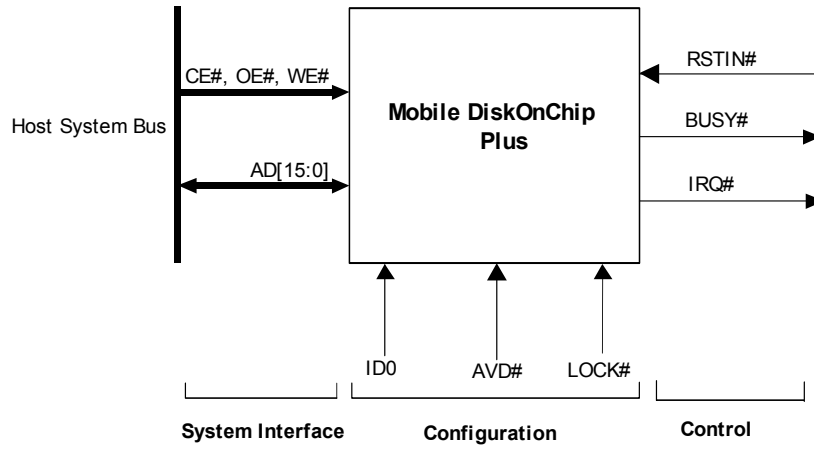

Figure 4: Multiplexed Interface Simplified I/O Diagram

2.3.3 Signal Description

The ball designations are listed in the signal descriptions, presented in logic groups, in Table 2.

Table 2: Multiplexed Interface Signal Descriptions

Signal	Ball No.	Input Type	Description	Signal Type
System Interface				
AD[15:12] AD[11:8] AD[7:4] AD[3:0]	H8, K8, H7, J7, K5, J4, H4, K3, J8, G7, K7, H6, H5, K4, G4, J3	IN	Multiplexed bus. Address and data signals.	Input/ Output
CE#	H2	ST, R	Chip Enable, active low.	Input
OE#	H3	ST	Output Enable, active low.	Input
WE#	C6	ST	Write Enable, active low.	Input
Configuration				
AVD#	G9 (For Mobile DiskOnChip 16MB only)	ST	Sets multiplexed interface. Multiplexed mode is automatically entered when a rising edge is detected on this ball.	Input
ID0	F8 (For Mobile DiskOnChip 16MB only)	ST	Identification. For Mobile DiskOnChip 16MB, up to two chips can be cascaded in the same memory window, according to the following assignment: Chip 1: ID0 = VSS; required for single chip Chip 2: ID0 = VCC	Input
LOCK#	E8	ST	Lock, active low. When active, provides full hardware data protection of selected partitions.	Input
Control				
BUSY#	E5	OD	Busy, active low, open drain. Indicates that DiskOnChip is initializing and should not be accessed. A 10 K Ω pull-up resistor is required even if the ball is not used.	Output
IRQ#	F9	-	Interrupt Request. Requires a 10 K Ω pull-up resistor.	Output
RSTIN#	D5	ST	Reset, active low.	Input
Power				
VCCQ	F4, J6		I/O power supply. Sets the logic '1' voltage level range of I/O balls/pins. VCCQ may be either 2.5V to 3.6V or 1.65V to 2.0V. Requires a 10 nF and 0.1 μ F capacitor.	Supply
VCC	J5	-	Device supply. All VCC balls must be connected; each VCC ball requires a 10 nF and a 0.1 μ F capacitor.	Supply
VSS	C3, C7, C8, D2, D3, D8, E2, E3, E4, E7, F2, F3, F7, G2, G3, J9	-	Ground. All VSS balls must be connected.	Supply

Signal	Ball No.	Input Type	Description	Signal Type
Reserved				
RSRVD	K6	-	Reserved signal that is not connected internally. Note: Future DiskOnChip devices will use this pin as a clock input. To be forward compatible, this pin can already be connected to the system CLK or to VCC when the clock input feature is not required.	
	Other. See Figure 3	-	Reserved signal that is not connected internally and must be left floating to guarantee forward compatibility with future products. It should not be connected to arbitrary signals.	
Mechanical				
-	M	-	Mechanical. These balls are for mechanical placement, and are not connected internally.	
-	A	-	Alignment. This ball is for device alignment, and is not connected internally.	

The following abbreviations are used:

IN	Standard (non-Schmidt) input
ST	Schmidt Trigger input
OD	Open drain
R8	Nominal 22 K Ω pull-up resistor, enabled only for 8-bit interface mode (IF_CFG input is 0)
R	3.7 M Ω nominal pull-up resistor

Note: For forward compatibility with future DiskOnChip 7x10 FBGA products, additional pads are required. Please refer to Application Note AP-DOC-067, *Preparing your PCB Footprint for the DiskOnChip BGA Migration Path*, for detailed information.

3. Theory of Operation

3.1 Overview

Mobile DiskOnChip Plus consists of the following major functional blocks, as shown in Figure 5.

- **System Interface** for host interface
- **Configuration Interface** for configuring Mobile DiskOnChip Plus to operate in 8/16-bit mode, cascaded configuration and hardware write protection.
- **Protection and Security-Enabling** containing write/read protection and One-Time Programming (OTP), for advanced data/code security and protection.
- **Programmable Boot Block** with XIP capability enhanced with a **Download Engine (DE)** for system initialization capability.
- **Reed-Solomon-based Error Detection and Error Correction Code (EDC/ECC)** for on-the-fly error handling.
- **Data Pipeline** through which the data flows from the system to the NAND flash arrays.
- **Control & Status** block that contains registers responsible for transferring the address, data and control information between the TrueFFS driver and the flash media.
- **Flash Interface** consists of a single 16MB NAND flash array (Figure 5). Mobile DiskOnChip Plus achieves a 32MB capacity using two stacked 16MB devices in a dual-die package.
- **Bus Control** for translating the host bus address, data and control signals into valid NAND flash signals.
- **Address Decoder** to enable the relevant unit inside the DiskOnChip controller, according to the address range received from the system interface.

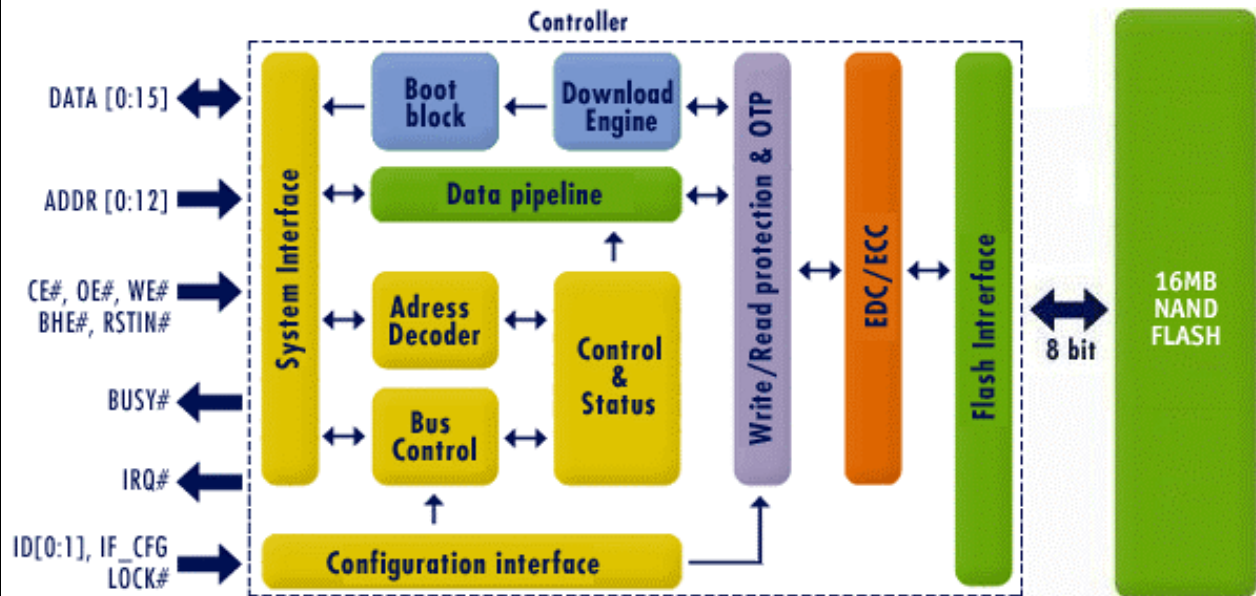

Figure 5: Standard Interface Simplified Block Diagram

3.2 System Interface

The system interface block provides an easy-to-integrate SRAM-like (also EEPROM-like) interface to Mobile DiskOnChip Plus, enabling it to interface with various CPU interfaces, such as a local bus, ISA bus, SRAM interface, EEPROM interface or any other compatible interface. In addition, the EEPROM-like interface enables direct access to the Programmable Boot Block to permit XIP functionality during system initialization.

A 13-bit wide address bus enables access to the DiskOnChip 8KB memory window (as shown in Section 6.2). The 16-bit data bus permits 16-bit wide access to the host. The internal access to the flash is 8-bit.

The Chip Enable (CE#), Write Enable (WE#) and Output Enable (OE#) signals trigger read and write cycles. A write cycle occurs while both the CE# and the WE# inputs are asserted. Similarly, a read cycle occurs while both the CE# and OE# inputs are asserted. Note that Mobile DiskOnChip Plus does not require a clock signal. Mobile DiskOnChip Plus features a unique analog static design, optimized for minimal power consumption. The CE#, WE# and OE# signals trigger the controller (e.g., system interface block, bus control and data pipeline) and flash access.

The Reset In (RSTIN#) and Busy (BUSY#) control signals are used in the reset phase. See Section 5.2 for further details.

The Interrupt Request (IRQ#) signal can be used when long I/O operations, such as Block Erase, delay the CPU resources. The signal is also asserted when a Data Protection violation has occurred. When this signal is implemented, the CPU can run other tasks and only returns to continue read/write operations with Mobile DiskOnChip Plus after the IRQ# signal has been asserted and an Interrupt Handling Routine (implemented in the OS) has been called to return control to the TrueFFS driver.

3.3 Configuration Interface

The Configuration Interface block enables the designer to configure Mobile DiskOnChip Plus to operate in different modes. The identification signals (ID[1:0]) are used for identifying the relevant DiskOnChip device in a cascaded configuration (see Section 9.6 on cascading for further details). The Lock (LOCK#) signal enables hard-wire hardware-controlled protection of code and data, as described below. For a standard interface, the Interface Configuration (IF_CFG) signal configures Mobile DiskOnChip Plus for 16-bit or 8-bit data access (see Section 9.5.4).

3.4 Protection and Security-Enabling Features

The protection and security-enabling block, consisting of read/write protection, UID and OTP area, enables advanced data and code security and protection. Located on the main route of traffic between the host and the flash, this block monitors and controls all data and code transactions to and from Mobile DiskOnChip Plus.

3.4.1 Read/Write Protection

Data and code protection is implemented through a Protection State Machine (PSM). The user can configure one or two independently programmable areas of the flash memory as read protected, write protected, or read/write protected.

A protection area may be protected by either/both of these hardware mechanisms:

- 64-bit protection key
- Hard-wired LOCK# signal

The size and location of each area is user-defined to provide maximum flexibility for the target platform and application requirements.

The configuration parameters of the protected areas are stored on the flash media and are automatically downloaded from the flash to the PSM upon power-up, to enable robust protection throughout the flash lifetime.

In the event of an attempt to bypass the protection mechanism, illegally modify the protection key or in any way sabotage the configuration parameters, the entire DiskOnChip becomes both read and write protected, and is completely inaccessible.

For further information on the hardware protection mechanism, refer to Section 4.

3.4.2 Unique Identification (UID) Number

Each Mobile DiskOnChip Plus is assigned a 16-byte UID number. Burned onto the flash during production, the UID cannot be altered and is unique worldwide. The UID is essential in security-related applications, and can be used to identify end-user products in order to fight fraudulent duplication by imitators.

The UID on Mobile DiskOnChip Plus eliminates the need for an additional on-board ID device, such as a dedicated EEPROM.

3.4.3 One-Time Programmable (OTP) Area

The 6KB OTP area is user-programmable for complete customization. The user can write to this area once, after which it is automatically locked permanently. After it is locked, the OTP area becomes read only, just like a ROM device.

Typically, the OTP area is used to store customer and product information such as: product ID, software version, production data, customer ID and tracking information.

3.5 Programmable Boot Block with eExecute In Place (XIP) Functionality

During boot, code must be executed directly from the flash media, rather than first copied to the host RAM and then executed from there. This direct XIP code execution functionality is essential for booting.

The Programmable Boot Block with XIP functionality enables Mobile DiskOnChip Plus to act as a boot ROM device in addition to being a flash disk. This unique design enables the user to benefit from the advantages of NOR flash, typically used for boot and code storage, and NAND flash, typically used for data storage. No other boot device is required on the motherboard.

Mobile DiskOnChip Plus 16MB contains a 1KB Programmable Boot Block, whereas Mobile DiskOnChip Plus 32MB contains a 2KB Programmable Boot Block. The Download Engine (DE) described in the next section expands the functionality of this block by copying the boot code from the flash into the boot block.

When the maximum number of Mobile DiskOnChip Plus devices are cascaded, the Programmable Boot Block provides 4KB of boot block area. The Programmable Boot Block of each device is mapped to a unique address space.

3.6 Download Engine (DE)

Upon power up or when the RSTIN# signal is asserted high, the DE automatically downloads the Initial Program Loader (IPL) from the flash to the Programmable Boot Block. The IPL is responsible for starting the boot process. The download process is quick (1.3 ms max) and is designed so that when the CPU accesses Mobile DiskOnChip Plus for code execution, the IPL code is already located in the Programmable Boot Block.

In addition, the DE downloads the Data Protection Structures (DPS) from the flash to the Protection State Machines (PSMs), so that Mobile DiskOnChip Plus is secure and protected from the first moment it is active.

During the download process, Mobile DiskOnChip Plus asserts the BUSY# signal to indicate to the system that it is not yet ready to be accessed. After BUSY# is negated, the system can access Mobile DiskOnChip Plus.

A failsafe mechanism prevents improper initialization due to a faulty VCC or invalid assertion of the RSTIN# input. Another failsafe mechanism is designed to overcome possible NAND flash data errors. It prevents internal registers from powering up in a state that bypasses the intended data protection. In addition, in any attempt to sabotage the data structures causes the entire Mobile DiskOnChip Plus to become both read- and write-protected and completely inaccessible.

3.7 Error Detection Code/Error Correction Code (EDC/ECC)

NAND flash, being an imperfect memory, requires error handling. Mobile DiskOnChip Plus implements Reed-Solomon Error Detection Code (EDC). A hardware-generated, 6-byte error detection signature is computed each time a page (512 bytes) is written to or read from Mobile DiskOnChip Plus.

The TrueFFS driver implements complementary Error Correction Code (ECC). Unlike error detection, which is required on every cycle, error correction is relatively seldom required, hence implemented in software. The combination of Mobile DiskOnChip Plus's built-in EDC mechanism and the TrueFFS driver ensures highly reliable error detection and correction, while providing maximum performance.

The following detection and correction capability is provided for each 512 bytes:

- Corrects up to two 10-bit symbols, including two random bit errors.
- Corrects single bursts up to 11 bits.
- Detects single bursts up to 31 bits and double bursts up to 11 bits.
- Detects up to 4 random bit errors.

3.8 Data Pipeline

Mobile DiskOnChip Plus uses a two-stage pipeline mechanism, designed for maximum performance while enabling on-the-fly data manipulation, such as read/write protection and Error Detection/Error Correction.

3.9 Control & Status

The Control & Status block contains registers responsible for transferring the address, data and control information between the DiskOnChip TrueFFS driver and the flash media. Additional registers are used to monitor the status of the flash media (ready/busy) and of the DiskOnChip controller. For further information on the Mobile DiskOnChip Plus registers, refer to Section 6.3).

3.10 Flash Architecture

A 16MB flash bank consists of 1024 blocks organized in 32 pages, as follows:

- **Page** – Each page contains 512 bytes of user data and a 16-byte extra area that is used to store flash management and EDC/ECC signature data, as shown in Figure 6. A page is the minimal unit for read/write operations.
- **Block** – Each block contains 32 pages (total of 16KB), as shown in Figure 7. A block is the minimal unit that can be erased, and is sometimes referred to as an erase block.

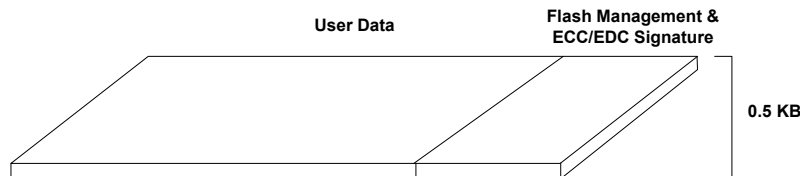

Figure 6: Page Structure

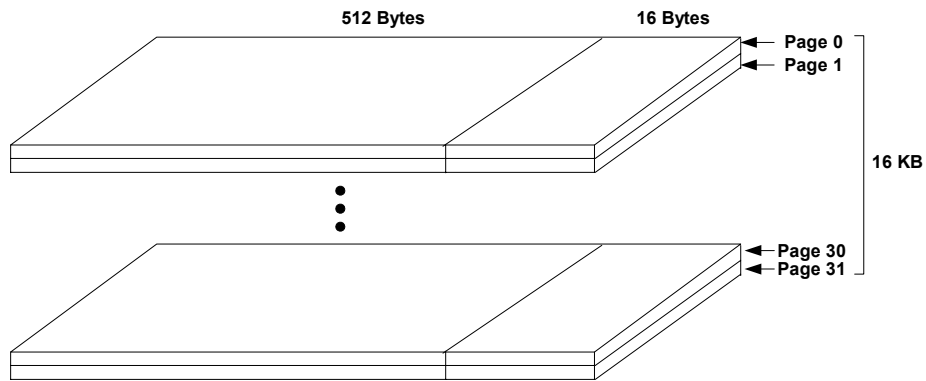

Figure 7: Block Structure

Mobile DiskOnChip Plus 32MB consists of two stacked 16MB devices, each designed with a single-bank 16MB flash array, consisting of 1024 blocks organized in 32 pages.

4. Hardware Protection

4.1 Method of Operation

Mobile DiskOnChip Plus enables the user to define two partitions that are protected (in hardware) against any combination of read or write operations. The two protected areas can be configured as read protected or write-protected, and are protected by a protection key (i.e. password) defined by the user. Each of the protected areas can be configured separately and can function separately, providing maximal flexibility for the user.

The size and protection attributes (protection key/read/write/changeable/lock) of the protected partition are defined in the media formatting stage (DFORMAT utility or the format function in the TrueFFS SDK).

In order to set or remove a read/write protection, the protection key (i.e., password) must be used, as follows:

- Insert the protection key to remove read/write protection.
- Remove the protection key to set read/write protection.

Mobile DiskOnChip Plus has an additional hardware safety measurement. If the Lock option is enabled (by means of software) and the LOCK# ball is asserted, the protected partition has an additional hardware lock that prevents read/write access to the partition, even with the use of the correct protection key. The LOCK# ball must be asserted during DFORMAT (and later when the partition is defined as changeable) to enable the additional hard-wired safety lock.

It is possible to set the Lock option for one session only, that is, until the next power-up or reset. This Sticky Lock feature can be useful when the boot code in the boot partition must be read/write protected. Upon power-up, the boot code must be unprotected so the CPU can run it directly from Mobile DiskOnChip Plus. At the end of the boot process, protection can be set until the next power-up or reset.

Setting the Sticky Lock (SLOCK) bit in the Output Control register to 1 has the same effect as asserting the LOCK# ball. Once set, SLOCK can only be cleared by asserting the RSTIN# input. Like the LOCK# input, the assertion of this bit prevents the protection key from disabling the protection for a given partition. For more information, see Section 7.9. The target partition does not have to be mounted before calling a hardware protection routine.

Only one partition can be defined as “changeable”; i.e., its password and attributes are fully configurable at any time (from read to write, both or none and visa versa). Note that “un-changeable” partition attributes cannot be changed unless the media is reformatted.

A change of any of the protection attributes causes a reset of the protection mechanism and consequently the removal of *all* device protection keys. That is, if the protection attributes of one partition are changed, the other partition will lose its key-protected read/write protection.

The only way to read or write from a read or write protected partition is to use the insert key call (even DFORMAT does not remove the protection). This is also true for modifying its attributes (key, read, write and lock enable state). Read/write protection is disabled in each one of the following events:

- Power-down
- Change of any protection attribute (not necessarily in the same partition)
- Write operation to the IPL area
- Removal of the protection key.

For further information on hardware protection, please refer to the *TrueFFS Software Development Kit (SDK)* developer guide or application note AP-DOC-057, *Protection and Security-Enabling Features in DiskOnChip Plus*.

4.2 Low-Level Structure of the Protected Area

The first three blocks on Mobile DiskOnChip Plus contain foundry information, the Data Protect structures, IPL code, and bad-block mapping information. See Figure 8.

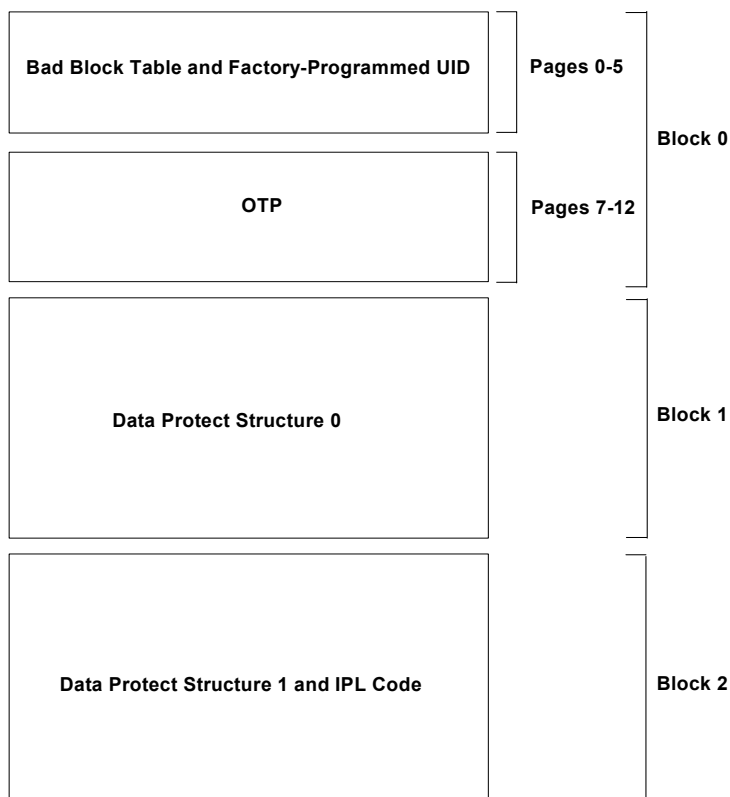

Figure 8: Low Level Structure of Mobile DiskOnChip Plus

Blocks 0, 1 and 2 in Mobile DiskOnChip Plus contain the following information:

Block 0

- Bad Block Table (page 2). Contains the mapping information to unusable Erase units on the flash media.
- UID (16 bytes). This number is written during the manufacturing stage, and cannot be altered at a later time.
- Customer OTP (occupies pages 26-31). The OTP area is written once and then locked.

Block 1

- Data Protect Structure 0. This structure contains configuration information on one of the two user-defined protected partitions.

Block 2

- Data Protect Structure 1. This structure contains configuration information on one of the two user-defined protected partitions.
- IPL Code (1KB). This is the boot code that is downloaded by the DE to the internal boot block.

5. Modes of Operation

Mobile DiskOnChip Plus has three modes of operation:

- Reset
- Normal
- Deep Power-Down

Mode changes can occur due to any of the following events, as shown in Figure 9:

- Assertion of the RSTIN# signal sets the device in Reset mode.
- During power-up, boot detector circuitry sets the device in Reset mode.
- A valid write sequence to Mobile DiskOnChip Plus sets the device in Normal mode. This is done automatically by the TrueFFS driver on power-up (reset sequence end).
- Switching back from Normal mode to Reset mode can be done by a valid write sequence to Mobile DiskOnChip Plus, or by triggering the boot detector circuitry (by soft reset).
- Power-down.
- A valid write sequence, initiated by software, sets the device from Normal mode to Deep Power-Down mode. Four read cycles from offset 0x1FFF set the device back to Normal mode. Alternately, the device can be set back to Normal mode with an extended access time during a read from the Programmable Boot Block (see Section 10.4.1 for read cycle timing).
- Asserting the RSTIN# signal and holding it in this state while in Normal mode puts the device in Deep Power-Down mode. When the RSTIN# signal is released, the device is set in Reset mode.

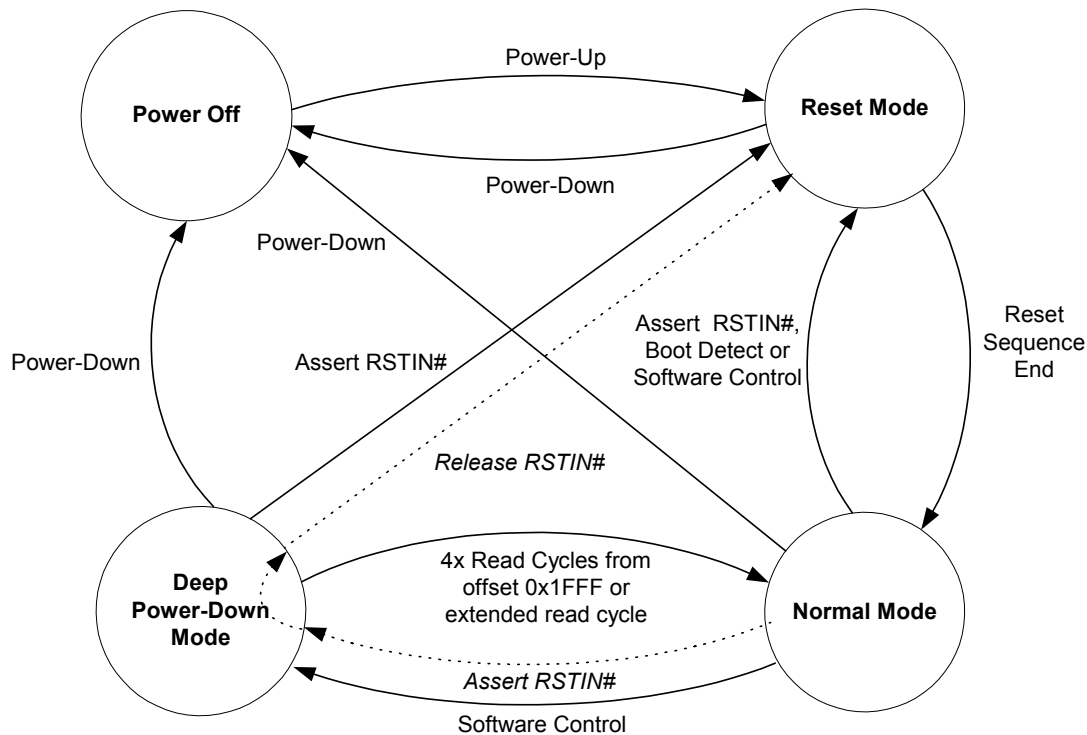

Figure 9: Operation Modes and Related Events

5.1 Normal Mode

This is the mode in which standard operations involving the flash memory are performed. Normal mode is automatically entered when a valid write sequence is sent to the DiskOnChip Control register and Control Confirmation register. The boot detector circuit triggers the software to set the device to Normal mode.

A write cycle occurs when both the CE# and WE# inputs are asserted. Similarly, a read cycle occurs when both the CE# and OE# inputs are asserted. Because the flash controller generates its internal clock from these CPU cycles and some read operations return volatile data, it is essential that the specified timing requirements contained in Section 10.4.1 be met. It is also essential that read and write cycles are not interrupted by glitches or ringing on the CE#, WE#, OE# address inputs. All inputs to Mobile DiskOnChip Plus are Schmidt Trigger types to improve noise immunity.

In Normal mode, Mobile DiskOnChip Plus responds to every valid hardware cycle. When there is no activity, it is possible to reduce the power consumption to a typical deep-power-down current of 10 μ A (16MB) or 20 μ A (32MB) by setting the device in Deep Power-Down mode.

5.2 Reset Mode

In Reset mode, Mobile DiskOnChip Plus ignores all write cycles, except for those to the DiskOnChip Control register and Control Confirmation register. All register read cycles return a value of 00H. Before attempting to perform a register read operation, the device is set to Normal mode by the TrueFFS software.

5.3 Deep Power-Down Mode

In Deep Power-Down mode, Mobile DiskOnChip Plus internal high current voltage regulators are disabled to reduce quiescent power consumption to 10 μ A (16MB) or 20 μ A (32MB) (Typ.). The following signals are also disabled in this mode:

- Standard interface: input buffers A[12:0], BHE#, WE#, D[15:0] and OE# (when CE# is negated)
- Multiplexed interface: input buffers AD[15:0], AVD#, WE# and OE# (when CE# is negated).

To enter Deep Power-Down mode, a proper sequence must be written to the DiskOnChip Control registers and DiskOnChip Control Confirmation register, and the CE# input must be negated (CE# = VCC). All other inputs should be VSS or VCC.

An additional option for setting the device into Deep Power-Down mode, when in Normal mode, is by asserting the RSTIN# signal and holding it in the low state (see the dotted line in Figure 9). When the RSTIN# signal is released, the device is set in Reset mode.

In Deep Power-Down mode, write cycles have no effect and read cycles return indeterminate data (Mobile DiskOnChip Plus does not drive the data bus). Entering Deep Power-Down mode and then returning to the previous mode does not affect the value of any register.

To exit Deep Power-Down mode, perform the following sequence:

- Read four times from address 1FFFH. The data returned is undefined. (This option is valid for both standard and multiplexed interfaces).
- Perform a single read cycle from the Programmable Boot Block with an extended access time and address hold time as specified in Section 10.4.1. The data returned will be correct.

Applications that require both Deep Power-Down mode and boot detection require BIOS support to ensure that Mobile DiskOnChip Plus exits from Power-Down mode prior to the expansion ROM scan. Similarly, applications that use Mobile DiskOnChip Plus as a boot ROM must ensure that the device is *not* in Deep Power-Down mode before reading the boot vector/instructions, either by pulsing RSTIN# to the asserted state and waiting for the BUSY# output to be negated, or by entering Reset mode via software.

6. TrueFFS Technology

6.1 General Description

M-Systems' patented TrueFFS technology was designed to maximize the benefits of flash memory while overcoming inherent flash limitations that would otherwise reduce its performance, reliability and lifetime. TrueFFS emulates a hard disk, making it completely transparent to the OS. In addition, since it operates under the OS file system layer (see Figure 10), it is completely transparent to the application.

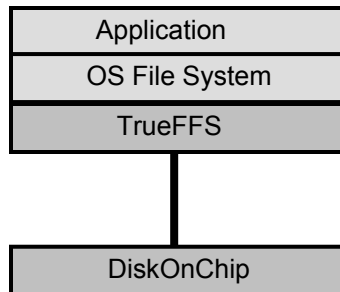

Figure 10: TrueFFS Location in System Hierarchy

TrueFFS technology support includes:

- Binary driver support for all major OSs
- *TrueFFS Software Development Kit (SDK)* developer guide
- *DiskOnChip Boot Software Development Kit (BDK)* developer guide
- Support for all major CPUs, including 8-, 16- and 32-bit bus architectures

TrueFFS technology features:

- Block device API
- Flash file system management
- Bad-block management
- Dynamic virtual mapping
- Dynamic and static wear-leveling
- Power failure management
- Implementation of Reed-Solomon EDC/ECC
- Performance optimization
- Compatibility with all DiskOnChip products

6.1.1 Built-In Operating System Support

The TrueFFS driver is integrated into all major OSs, including Symbian OS, Windows CE, Pocket PC, Smartphone, OSE, Nucleus, and others. For a complete listing of all available drivers, please refer to M-Systems' website <http://www.m-sys.com>. It is advised to use the latest driver versions that can be downloaded from the Mobile DiskOnChip Plus web page on the M-Systems site.

6.1.2 TrueFFS Software Development Kit (SDK)

The basic *TrueFFS Software Development Kit (SDK)* provides the source code of the TrueFFS driver. It can be used in an OS-less environment or when special customization of the driver is required for proprietary OSs.

When using Mobile DiskOnChip Plus as the boot replacement device, the TrueFFS SDK also incorporates in its source code the BDK, software that is required for this configuration (this package is also available separately). Please refer to the *DiskOnChip Boot Software Development Kit (BDK)* developer guide for further information on using this software package.

6.1.3 File Management

TrueFFS accesses the flash memory within Mobile DiskOnChip Plus through an 8KB window in the CPU memory space. It provides block device API, by using standard file system calls, identical to those used by a mechanical hard disk, to enable reading from and writing to any sector on Mobile DiskOnChip Plus. This makes it compatible with any file system and file system utilities such as diagnostic tools and applications. When using the File Allocation Table (FAT) file system, the data stored on Mobile DiskOnChip Plus uses FAT-16.

Note: Mobile DiskOnChip Plus is shipped unformatted and contains virgin media.

6.1.4 Bad-Block Management

As NAND flash is an imperfect storage media, it contains some bad blocks that cannot be used for storage because of their high error rates. TrueFFS automatically detects and maps bad blocks upon system initialization, ensuring that they are not used for storage. This management process is completely transparent to the user, who remains unaware of the existence and location of bad blocks, while remaining confident of the integrity of data stored. The Bad Block Table on Mobile DiskOnChip Plus is hardware-protected for ensured reliability.

6.1.5 Wear-Leveling

Flash memory can be erased a limited number of times. This number is called the *erase cycle limit* or *write endurance limit* and is defined by the flash array vendor. The erase cycle limit applies to each individual erase block in the flash device. In Mobile DiskOnChip Plus, the erase cycle limit of the flash is 300,000 erase cycles. This means that after approximately 300,000 erase cycles, the erase block begins to make storage errors at a rate significantly higher than the error rate that is typical to the flash.

In a typical application and especially if a file system is used, a specific page or pages are constantly updated (e.g., the page/s that contain the FAT, registry etc.). Without any special handling, these pages would wear out more rapidly than other pages, reducing the lifetime of the entire flash.

To overcome this inherent deficiency, TrueFFS uses M-Systems' patented wear-leveling algorithm. The wear-leveling algorithm ensures that consecutive writes of a specific sector are not written physically to the same page in the flash. This spreads flash media usage evenly across all pages, thereby maximizing flash lifetime. TrueFFS wear-leveling extends the flash lifetime 10 to 15 years beyond the lifetime of a typical application.

Dynamic Wear-Leveling

TrueFFS uses statistical allocation to perform dynamic wear-leveling on newly written data. This not only minimizes the number of erase cycles per block, it also minimizes the total number of erase cycles. Because a block erase is the most time-consuming operation, dynamic wear-leveling has a major impact on overall performance. This impact cannot be noticed during the first write to flash (since there is no need to erase blocks beforehand), but it is more and more noticeable as the flash media becomes full.

Static Wear-Leveling

Areas on the flash media may contain static files, characterized by blocks of data that remain unchanged for very long periods of time, or even for the whole device lifetime. If wear-leveling were only applied on newly written pages, static areas would never be cycled. This limited application of wear-leveling would lower life expectancy significantly in cases where flash memory contains large static areas. To overcome this problem, TrueFFS forces data transfer in static areas as well as in dynamic areas, thereby applying wear-leveling to the entire media.

6.1.6 Power Failure Management

TrueFFS uses algorithms based on “erase after write” instead of “erase before write” to ensure data integrity during normal operation and in the event of a power failure. Used areas are reclaimed for erasing and writing the flash management information into them only *after* an operation is complete. This procedure serves as a check on data integrity.

The “erase after write” algorithm is also used to update and store mapping information on the flash memory. This keeps the mapping information coherent even during power failures. The only mapping information held in RAM is a table pointing to the location of the actual mapping information. This table is reconstructed during power-up or after reset from the information stored in the flash memory.

To prevent data from being lost or corrupted, TrueFFS uses the following mechanisms:

- When writing, copying, or erasing the flash device, the data format remains valid at all intermediate stages. Previous data is never erased until the operation has been completed and the new data has been verified.
- A data sector cannot exist in a partially written state. Either the operation is successfully completed, in which case the new sector contents are valid, or the operation has not yet been completed or has failed, in which case the old sector contents remain valid.

6.1.7 Error Detection/Correction

TrueFFS implements a Reed-Solomon Error Correction Code (ECC) algorithm to ensure data reliability. Refer to Section 3.7 for further information on the EDC/ECC mechanism.

6.1.8 Special Features through I/O Control (IOCTL) Mechanism

In addition to standard storage device functionality, the TrueFFS driver provides extended functionality. This functionality goes beyond simple data storage capabilities to include features such as: format the media, read/write protect, binary partition(s) access, flash defragmentation and other options. This unique functionality is available in all TrueFFS-based drivers through the standard I/O control command of the native file system.

For further information, please refer to the *Extended Functions of the TrueFFS Driver for DiskOnChip* developer guide.

6.1.9 Compatibility

The TrueFFS driver supports all released DiskOnChip products. Upgrading from one product to another requires no additional software integration.

When using different drivers (e.g. TrueFFS SDK, BDK, BIOS extension firmware, etc.) to access Mobile DiskOnChip Plus, the user must verify that all software is based on the same code base version. It is also important to use only tools (e.g. DFORMAT, DINFO, GETIMAGE, etc.) derived from the same version as the firmware version and the TrueFFS drivers used in the application. Failure to do so may lead to unexpected results, such as lost or corrupted data. The driver and firmware version can be verified by the sign-on messages displayed, or by the version information stored in the driver or tool.

Note: When a new M-Systems DiskOnChip product with new features is released, a new TrueFFS version is required.

6.2 8KB Memory Window in Mobile DiskOnChip Plus 16MB

TrueFFS utilizes an 8KB memory window in the CPU address space consisting of four 2KB sections, as depicted in Figure 11. When in Reset mode, the Programmable Boot Block in sections 0 and 3 will show the IPL (1KB), aliased twice, to support systems that search for a checksum at the boot stage from the top and bottom of memory. Read cycles from sections 1 and 2 always return the value 00H to create a fixed and known checksum. When in Normal mode, sections 1 and 2 are used for the internal registers.

The addresses described here are relative to the absolute starting address of the 8KB memory window.

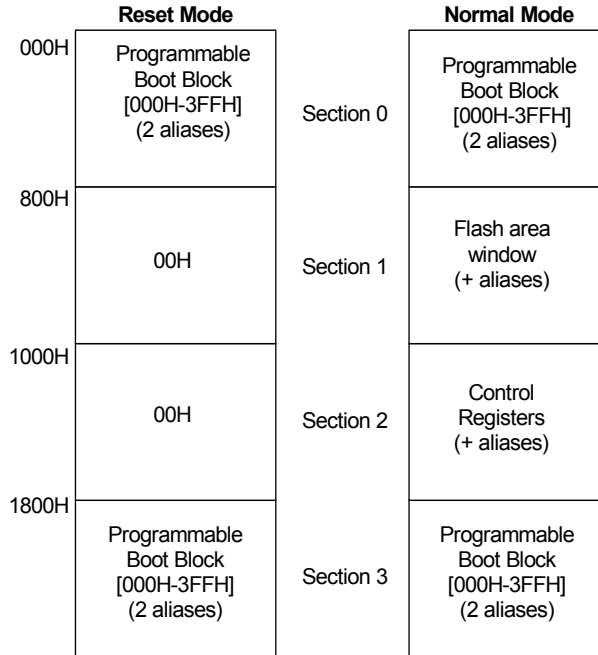

Figure 11: Mobile DiskOnChip Plus 16MB Memory Map

6.3 8KB Memory Window for Mobile DiskOnChip Plus 32MB

TrueFFS utilizes an 8KB memory window in the CPU address space consisting of four 2KB sections, as depicted in Figure 11. When in Reset mode, the Programmable Boot Block in sections 0 and 3 will show the IPL (1KB) of the first 16MB of the dual die, aliased twice. Read cycles from sections 1 and 2 always return the value 00H to create a fixed and known checksum.

After setting the MAX_ID field in the Configuration register (done by IPL0), the second copy of IPL0 is replaced with the IPL of the second 16MB device of the dual die, thereby creating a 2KB Programmable Boot Block.

When in Normal mode, sections 1 and 2 are used for the internal registers. The Programmable Boot Block in section 0 contains IPL0 and IPL1. Section 3 contains IPL0 aliased twice.

The addresses described here are relative to the absolute starting address of the 8KB memory window.

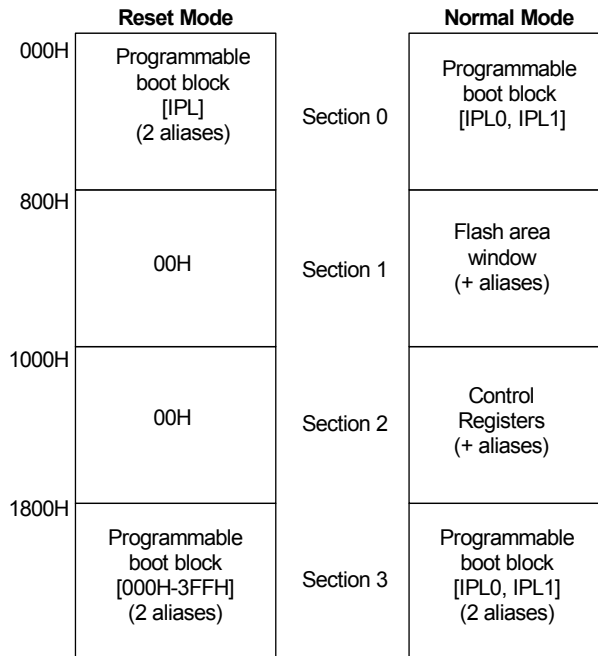

Figure 12: Mobile DiskOnChip Plus 32MB Memory Map

7. Register Descriptions

This section describes various Mobile DiskOnChip Plus registers and their functions, as listed in Table 3. This section can be used to enable the designer to better evaluate DiskOnChip technology.

Table 3: Mobile DiskOnChip Plus Registers

Address (Hex)	Register Name
1000	Chip Identification (ID)
1002	No Operation (NOP)
1004	Test
1006	DiskOnChip Control
1008	Device ID Select
100A	Configuration
100C	Output Control
100E	Interrupt Control
1046	Toggle Bit
1076	DiskOnChip Control Confirmation

7.1 Definition of Terms

The following abbreviations and terms are used within this section:

- RFU Reserved for future use. This bit is undefined during a read cycle and “don’t care” during a write cycle.
- RFU_0 Reserved for future use; when read, this bit always returns the value 0; when written, software should ensure that this bit is always set to 0.
- RFU_1 Reserved for future use; when read, this bit always returns the value 1; when written, software should ensure that this bit is always set to 1.
- Reset Value Refers to the value immediately present after exiting from Reset mode to Normal mode.

7.2 Reset Values

All registers return 00H while in Reset mode. The Reset value written in the register description is the register value after exiting Reset mode and entering Normal mode. Some register contents are undefined at that time (N/A).

7.3 Chip Identification (ID) Register

- Description: This register is used to identify the device residing on the host platform. It always returns 41H when read.
- Address (hex): 1000
- Type: Read only
- Reset Value: 41H

Bit 7	Bit 6	Bit 5	Bit 4	Bit 3	Bit 2	Bit 1	Bit 0
41H							

7.4 No Operation (NOP) Register

Description: A call to this register results in no operation. To aid in code readability and documentation, software should access this register when performing cycles intended to create a time delay.

Address (hex): 1002

Type: Write

Reset Value: None

7.5 Test Register

Description: This register enables software to identify multiple Mobile DiskOnChip Plus devices or multiple aliases in the CPUs memory space. Data written is stored but does not affect the behavior of Mobile DiskOnChip Plus.

Address (hex): 1004

Type: Read/Write

Reset Value: 00H

Bit 7	Bit 6	Bit 5	Bit 4	Bit 3	Bit 2	Bit 1	Bit 0
D[7:0]							

Bit No.	Description
0-7	D[7:0]: Data bits

7.6 DiskOnChip Control Register/Control Confirmation Register

Description: These two registers are identical and contain information on the operation mode of Mobile DiskOnChip Plus. After writing the required value to the DiskOnChip Control register, the complement of that data byte must also be written to the Control Confirmation register. The two writes cycles must not be separated by any other read or write cycles to the Mobile DiskOnChip Plus memory space, except for reads from the Programmable Boot Block space.

Address (hex): 1006/1076

Type: Read/Write

Reset Value: 10H

Bit 7	Bit 6	Bit 5	Bit 4	Bit 3	Bit 2	Bit 1	Bit 0
RFU_0			RST_LAT	BDET	MDWREN	Mode[1:0]	

Bit No.	Description
0-1	Mode. These bits select the mode of operation, as follows: 00: Reset 01: Normal 10: Deep Power-Down
2	MDWREN (Mode Write Enable). This bit must be set to 1 before changing the mode of operation.
3	BDET (Boot Detect). This bit is set whenever the device has entered Reset mode as a result of the Boot Detector triggering. It is cleared by writing a 1 to this bit.
4	RST_LAT (Reset Latch). This bit is set whenever the device has entered the Reset mode as a result of the RSTIN# input signal being asserted or the internal voltage detector triggering. It is cleared by writing a 1 to this bit.
5-7	Reserved for future use

7.7 Device ID Select Register

Description: In a cascaded configuration, this register controls which device provides the register space. The value of bits ID[0:1] is compared to the value of the ID configuration input balls, as defined in Section 9.6. The device whose ID input balls matches the value of bits ID[0:1] responds to read and write cycles to register space.

Address (hex): 1008

Type: Read/Write

Reset Value: 00H

Bit 7	Bit 6	Bit 5	Bit 4	Bit 3	Bit 2	Bit 1	Bit 0
RFU_0						ID[1:0]	

Bit No.	Description
0-1	ID[1:0] (Identification). The device whose ID input balls matches the value of bits ID[0:1] responds to read and write cycles to register space.
2-7	Reserved for future use

7.8 Configuration Register

Description: This register indicates the current configuration of the device. Unless otherwise noted, the bits are reset only by a hardware reset, and not upon boot detection or any other entry to Reset mode.

Address (hex): 100A

Type: Read/Write (except bit 7, which is Read Only)

Reset Value: X0000X10

Bit 7	Bit 6	Bit 5	Bit 4	Bit 3	Bit 2	Bit 1	Bit 0
IF_CFG	RFU_0	MAX_ID		RFU		RFU_0	

Bit No.	Description
0-3, 6	Reserved for future use
4-5	MAX_ID (Maximum Device ID). This field controls the RAM address mapping when multiple devices are used in a cascaded configuration, using the ID[1:0] inputs. It should be programmed to the highest ID value that is found by software in order to map all available boot blocks into usable address space.
7	IF_CFG (Interface Configuration). Reflects the state of the IF_CFG input pin.

7.9 Output Control Register

Description: This register controls the behavior of certain output balls.

Address (hex): 100C

Type: Read/Write

Reset Value: 01H

Bit 7	Bit 6	Bit 5	Bit 4	Bit 3	Bit 2	Bit 1	Bit 0
RFU_0				SLOCK	RFU_1	RFU_0	RFU_1

Bit No.	Description
0-2, 4-7	Reserved for future use.
3	SLOCK [Sticky Lock]. Setting this bit to a 1 has the same effect as asserting the LOCK# input, up until the next power-up or reset. Once set, this bit can only be cleared by asserting the RSTIN# input. Like the LOCK# input, the assertion of this bit prevents the protection key from disabling the protection for a given partition if the value of the LOCK bit in its respective Data Protect Structure is set. When read, this bit always returns the value 0. Setting this bit affects the state of the LOCK# bit in the Protection Status register.

Note: For further information on the Output Control and Protection Status registers, refer to the addendum to this data sheet, *Mobile DiskOnChip Plus/DIMM Plus Register Description*.

7.10 Interrupt Control

Description: Interrupts may be generated when the flash transitions from the busy state to the ready state, or by a data protection violation.

Address (hex): 100E

Type: Read/Write

Reset Value: 00H

Bit 7	Bit 6	Bit 5	Bit 4	Bit 3	Bit 2	Bit 1	Bit 0
RFU_0	IRQ_P	IRQ_F	EDGE	PROT_T	FRDY_T[2:0]		

Bit No.	Description
0-2	FRDY_T[2:0] (Flash Ready Trigger). This field determines if an interrupt will be generated when the flash array of Mobile DiskOnChip Plus is ready, as follows: 000: Interrupts are disabled – Holds the IRQ# output in the negated state. 001: Interrupt when flash array is ready.
3	PROT_T (Protection Trigger). When set, an interrupt is generated upon a data protection violation.
4	EDGE (Edge-sensitive interrupt) 0: Specifies level-sensitive interrupts in which the IRQ# output remains asserted until the interrupt is cleared. 1: Specifies edge-sensitive interrupts in which the IRQ# output pulses low.
5	IRQ_F: (Interrupt Request when flash array is ready) Indicates that the IRQ# output has been asserted due to an indication that the flash array is ready. Writing 1 to this bit clears its value,

	negates the IRQ# output and permits subsequent interrupts to occur.
6	IRQ_P (Interrupt Request on Protection Violation). Indicates that the IRQ# output has been asserted due to a data protection violation. Writing a 1 to this bit clears its value, negates the IRQ# output and permits subsequent interrupts to occur.
7	Reserved for future use.

7.11 Toggle Bit Register

Description: This register identifies the presence of the device.

Address (hex): 1046

Type: Read Only

Reset Value: 82H

Bit 7	Bit 6	Bit 5	Bit 4	Bit 3	Bit 2	Bit 1	Bit 0
RFU			RFU_0	RFU	TOGGLE	RFU_1	RFU

Bit No.	Description
0, 1, 3-7	Reserved for future use.
2	TOGGLE. This read-only bit toggles on consecutive reads and identifies the presence of the device.

8. Booting from Mobile DiskOnChip Plus

8.1 Introduction

Mobile DiskOnChip Plus can function both as a flash disk and the system boot device. If DiskOnChip is configured as a flash disk, it can operate as the OS boot device. DiskOnChip default firmware contains drivers to enable it to perform as the OS boot device under DOS (see Section 8.2). For other OSs, please refer to the *readme* file of the TrueFFS driver.

If Mobile DiskOnChip Plus is configured as a flash disk and as the system boot device, it contains the boot loader, an OS image and a file system. In such a configuration, Mobile DiskOnChip Plus can serve as the only non-volatile device on board. Refer to Section 8.3.2 for further information on boot replacement.

8.2 Boot Procedure in PC-Compatible Platforms

When used in PC-compatible platforms, Mobile DiskOnChip Plus is connected to an 8KB memory window in the BIOS expansion memory range, typically located between 0C8000H to 0EFFFFH. During the boot process, the BIOS loads the TrueFFS firmware into the PC memory and installs Mobile DiskOnChip Plus as a disk drive in the system. When the operating system is loaded, Mobile DiskOnChip Plus is recognized as a standard disk. No external software is required to boot from Mobile DiskOnChip Plus.

Figure 13 illustrates the location of the Mobile DiskOnChip Plus memory window in the PC memory map.

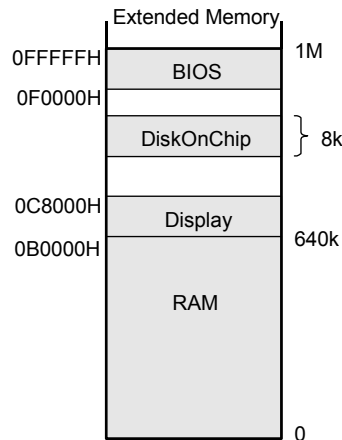

Figure 13: Mobile DiskOnChip Plus Memory Window in PC Memory Map

After reset, the BIOS code first executes the Power On Self-Test (POST) and then searches for all expansion ROM devices. When Mobile DiskOnChip Plus is located, the BIOS code executes from it the IPL code, located in the XIP portion of the Programmable Boot Block. This code loads the TrueFFS driver into system memory, installs Mobile DiskOnChip Plus as a disk in the system, and then returns control to the BIOS code. The operating system subsequently identifies Mobile DiskOnChip Plus as an available disk. TrueFFS responds by emulating a hard disk.

From this point onward, Mobile DiskOnChip Plus appears as a standard disk drive. It is assigned a drive letter and can be used by any application, without any modifications to either the BIOS set-up or the autoexec.bat/config.sys files. Mobile DiskOnChip Plus can be used as the only disk in the system, with or without a floppy drive, and with or without hard disks.

The drive letter assigned depends on how Mobile DiskOnChip Plus is used in the system, as follows:

- If Mobile DiskOnChip Plus is used as the only disk in the system, the system boots directly from it and assigns it drive C.
- If Mobile DiskOnChip Plus is used with other disks in the system:
 - Mobile DiskOnChip Plus can be configured as the last drive (the default configuration). The system assigns drive C to the hard disk and drive D to Mobile DiskOnChip Plus.
 - Alternatively, Mobile DiskOnChip Plus can be configured as the system's first drive. The system assigns drive D to the hard disk and drive C to Mobile DiskOnChip Plus.
- If Mobile DiskOnChip Plus is used as the OS boot device when configured as drive C, it must be formatted as a bootable device by copying the OS files onto it. This is done by using the SYS command when running DOS.

8.3 Boot Replacement

8.3.1 PC Architectures

In current PC architectures, the first CPU fetch (after reset is negated) is mapped to the boot device area, also known as the *reset vector*. The reset vector in PC architectures is located at address FFFF0, by using a Jump command to the beginning of the BIOS chip (usually F0000 or E0000). The CPU executes the BIOS code, initializes the hardware and loads Mobile DiskOnChip Plus software using the BIOS expansion search routine (e.g. D0000). Refer to Section 8.2 for a detailed explanation on the boot sequence in PC-compatible platforms.

Mobile DiskOnChip Plus implements both disk and boot functions when it replaces the BIOS chip. To enable this, Mobile DiskOnChip Plus requires a location at two different addresses:

- After power-up, Mobile DiskOnChip Plus must be mapped in F segment, so that the CPU fetches the reset vector from address FFFF0, where Mobile DiskOnChip Plus is located.
- After the BIOS code is loaded into RAM and starts execution, Mobile DiskOnChip Plus must be reconfigured to be located in the BIOS expansion search area (e.g. D0000) so it can load the TrueFFS software.

This means that the CS# signal must be remapped between two different addresses. For further information on how to achieve this, refer to application note AP-DOC-047, *Designing DiskOnChip as a Flash Disk and Boot Device Replacement*.

8.3.2 Non-PC Architectures

In non-PC architectures, the boot code is executed from a boot ROM, and the drivers are usually loaded from the storage device.

When using Mobile DiskOnChip Plus as the system boot device, the CPU fetches the first instructions from the Mobile DiskOnChip Plus Programmable Boot Block, which contains the IPL. Since in most cases this block cannot hold the entire boot loader, the IPL runs minimum initialization, after which the Secondary Program Loader (SPL) is copied to RAM from flash. The remainder of the boot loader code then runs from RAM.

The IPL and SPL are located in a separate (binary) partition on Mobile DiskOnChip Plus, and can be hardware protected if required.

For further information on software boot code implementation, refer to application note AP-DOC-044, *Writing an IPL for DiskOnChip Plus 16MByte Devices*.

8.3.3 Using Mobile DiskOnChip Plus in Asynchronous Boot Mode

Platforms that host CPUs that wake up in burst mode should use Asynchronous Boot mode when using Mobile DiskOnChip Plus as the system boot device.

During platform initialization, certain CPUs wake up in 32-bit mode and issue instruction fetch cycles continuously. An XScale CPU, for example, initiates a 16-bit read cycle, but after the first word is read, it continues to hold CE# and OE# asserted while it increments the address and reads additional data as a burst. A StrongARM CPU wakes up in 32-bit mode and issues double-word instruction fetch cycles.

Since Mobile DiskOnChip Plus derives its internal clock signal from the CE#, OE# and WE# inputs, it cannot distinguish between these burst cycles. To support this type of access, Mobile DiskOnChip Plus needs to be set in Asynchronous Boot mode.

To set Mobile DiskOnChip Plus in Asynchronous Boot mode, set the byte RAM MODE SELECT to 8FH. This can be done through the Mobile DiskOnChip Plus format utility or by customizing the IPL code. For more information on the format utility, refer to the *DiskOnChip Software Utilities* user manual or the *TrueFFS Software Development Kit (SDK)* developer guide. For further details on customizing the IPL code, refer to application note AP-DOC-044, *Writing an IPL for DiskOnChip Plus 16MByte*.

Once in Asynchronous Boot mode, the CPU can fetch its instruction cycles from the Mobile DiskOnChip Plus Programmable Boot Block. After reading from this block and completing boot, Mobile DiskOnChip Plus returns to derive its internal clock signal from the CE#, OE# and WE# inputs. Please refer to Section 10.4 for read timing specifications for Asynchronous Boot mode.

9. Design Considerations

9.1 Design Environment

Mobile DiskOnChip Plus provides a complete design environment consisting of:

- Evaluation Boards (EVB) for enabling software integration and development with Mobile DiskOnChip Plus, even before the target platform is available. An EVB with Mobile DiskOnChip Plus soldered on it is available with an ISA standard connector and a PCI standard connector for immediate plug-and-play usage.
- Programming solutions:
 - o GANG programmer
 - o Programming house
 - o On-board programming
- TrueFFS Software Development Kit (SDK) and BDK
- DOS utilities:
 - o DFORMAT
 - o GETIMG/PUTIMG
 - o DINFO
- Documentation:
 - o Data sheet
 - o Application notes
 - o Technical notes
 - o Articles
 - o White papers

Please visit the M-Systems website (www.m-sys.com) for the most updated documentation, utilities and drivers.

9.2 System Interface

9.2.1 Standard Interface

Mobile DiskOnChip Plus uses an SRAM-like interface that can easily be connected to any microprocessor bus. With a standard interface, it requires 13 address lines, 8 data lines and basic memory control signals (CE#, OE#, WE#), as shown in Figure 14 below. Typically, Mobile DiskOnChip Plus can be mapped to any free 8KB memory space. In a PC compatible platform, it is usually mapped into the BIOS expansion area. If the allocated memory window is larger than 8KB, an automatic anti-aliasing mechanism prevents the firmware from being loaded more than once during the ROM expansion search.

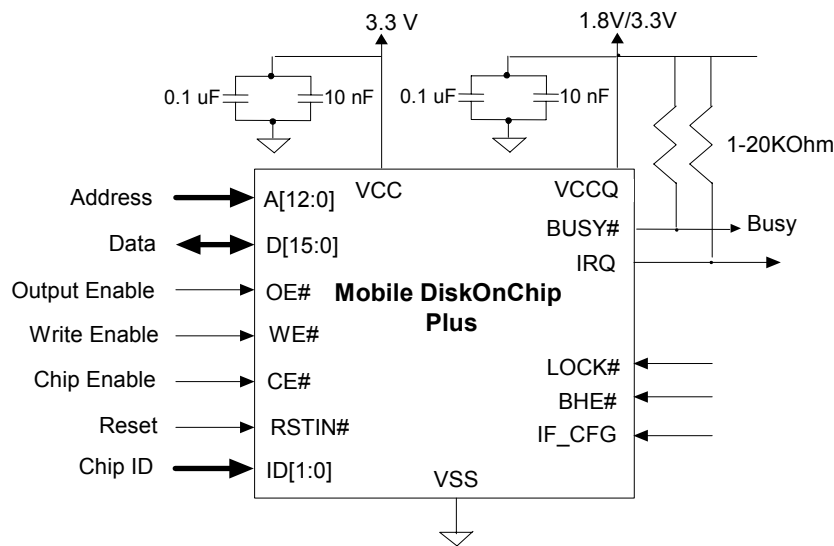

Figure 14: Standard System Interface

- Notes:
1. The 0.1 μ F and the 10 nF low-inductance high-frequency capacitors must be attached to each of the device's VCC and VSS balls. These capacitors must be placed as close as possible to the package leads.
 2. Mobile DiskOnChip Plus is an edge-sensitive device. CE#, OE# and WE# should be properly terminated (according to board layout, serial parallel or both terminations) to avoid signal ringing.
 3. All capacities support the standard interface.

9.2.2 Multiplexed Interface

With a multiplexed interface, Mobile DiskOnChip Plus requires the signals shown in Figure 15 below.

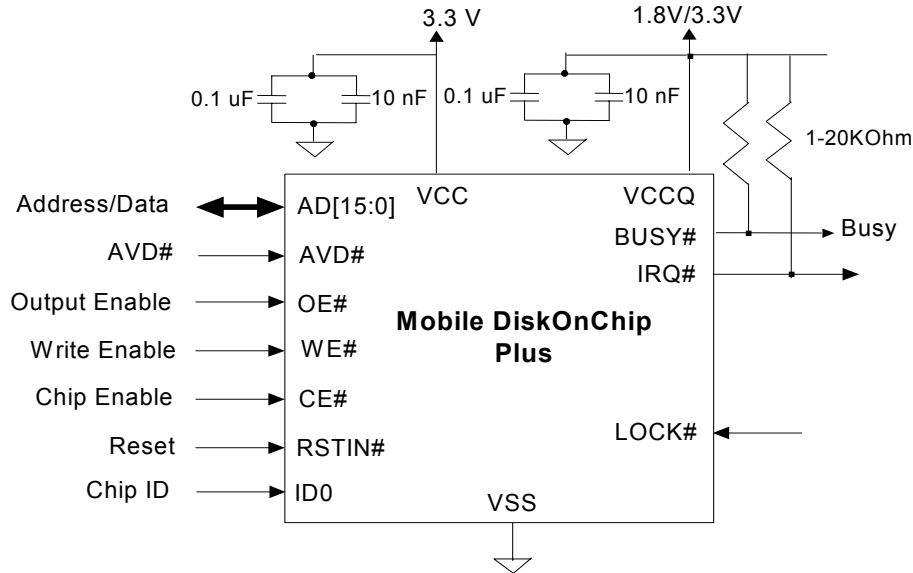

Figure 15: Multiplexed System Interface

9.3 Connecting Signals

9.3.1 Standard Interface

Mobile DiskOnChip Plus uses standard SRAM-like control signals, which should be connected as follows:

- Address (A[12:0]) – Connect these signals to the host address bus.
- Data (D[15:0]) – Connect these signals to the host data bus.
- Write (WE#) and Output Enable (OE#) – Connect these signals to the host WR# and RD# signals, respectively.
- Chip Enable (CE#) – Connect this signal to the memory address decoder.
- Chip Identification (ID[0:1]) – Both signals must be connected to GND if only one Mobile DiskOnChip Plus is being used. If more than one, refer to Section 9.6 for more information on cascaded configuration.
- Power-On Reset In (RSTIN#) – Connect this signal to the host Power-On Reset signal.
- Busy (BUSY#) – Connect this signal to an input port. It indicates when the device is ready for first access after hardware reset.
- Interrupt (IRQ#) – Connect this signal to the host interrupt to release the host of this task and improve performance.
- Byte High Enable (BHE#) – This signal definition is compatible with 16 bit platforms that use the BHE#/BLE# protocol. This signal is only relevant during the boot phase.
- Hardware Lock (LOCK#) – This signal prevents the use of the write protect key to disable the protection.
- 8/16 Bit Configuration (IF_CFG) – This signal is required for configuring the device for 8 or 16-bit access mode. When negated, the device is configured for 8-bit access mode. When asserted, 16-bit access mode is operative.

Mobile DiskOnChip Plus derives its internal clock signal from the CE#, OE# and WE# inputs. Since access to Mobile DiskOnChip Plus' registers is volatile, much like a FIFO or UART, ensure that these signals have clean rising and falling edges, and are free from ringing that can be interpreted as multiple edges. PC board traces for these three signals must either be kept short or properly terminated to guarantee proper operation.

9.3.2 Multiplexed Interface

Mobile DiskOnChip Plus can also be configured to work with a multiplexed interface where data and address line are multiplexed. In this configuration, AVD# input is driven by the host's AVD# signal, and the D[15:0] pins, used for both address and data, are connected to the host AD[15:0] bus. DiskOnChip address lines A[12:0] and BHE# should be connected to VSS. IF_CFG should be connected to VCC.

Note: When used in a multiplexed interface, it is not possible to cascade Mobile DiskOnChip Plus 32MB.

This mode is automatically entered when a falling edge is detected on AVD# input. This edge must occur after RSTIN# is negated and before OE# and CE# are both asserted, i.e. the first read cycle made to Mobile DiskOnChip Plus must observe the multiplex mode protocol.

Please refer to Section 2.3 for pinout and signal descriptions and to Section 10.4.3 for timing specifications for a multiplexed interface.

9.4 Implementing the Interrupt Mechanism

9.4.1 Hardware Configuration

To configure the hardware, connect the IRQ# pin to the host interrupt input.

Note: A nominal 10 K Ω pull-up resistor must be connected to this pin.

9.4.2 Software Configuration

Configuring the software to support the IRQ# interrupt is performed in two stages.

Stage 1

Configure the software so that upon system initialization, the following steps occur:

1. The correct value is written to the Interrupt Control register to configure Mobile DiskOnChip Plus for:
 - Interrupt source: Flash ready and/or data protection
 - Output sensitivity: Either edge or level triggered

Note: Refer to Section 7.10 for further information on the value to be written to this register.

2. The host interrupt is configured to the selected input sensitivity, either edge or level.
3. The handshake mechanism between the interrupt handler and the OS is initialized.
4. The interrupt service routine to the host interrupt is connected and enabled.

Stage 2

Configure the software so that for every long flash I/O operation, the following steps occur:

1. The correct value is written to the Interrupt Control register to enable the IRQ# interrupt.

Note: Refer to Section 7.10 for further information on the value to be written to this register.

2. The flash I/O operation starts.
3. Control is returned to the OS to continue other tasks. When the IRQ# interrupt is received, other interrupts are disabled and the OS is flagged.

4. The OS either returns control immediately to the TrueFFS driver, or waits for the appropriate condition to return control to the TrueFFS driver.

For further information on implementing the interrupt mechanism, please refer to application note AP-DOC-063, *Improving the Performance of DiskOnChip Plus Devices Using the IRQ# Pin*.

9.5 Platform-Specific Issues

The following section describes hardware design issues.

9.5.1 Wait State

Wait states can be implemented only when Mobile DiskOnChip Plus is designed in a bus that supports a Wait state insertion, and supplies a WAIT signal.

9.5.2 Big and Little Endian Systems

Power PC, ARM, and other RISC processors can use either Big or Little Endian systems. Mobile DiskOnChip Plus uses the Little Endian system. Therefore, bytes D[7:0] are its Least Significant Byte (LSB) and bytes D[15:8] are its Most Significant Byte (MSB). Within the bytes, bit D0 and bit D8 are the least significant bits of their respective byte. When connecting Mobile DiskOnChip Plus to a device that supports the Big Endian system, make sure to that the bytes of the CPU and Mobile DiskOnChip Plus match.

Note: Processors like the Power PC also change the bit ordering within the bytes. Failing to follow these rules results in improper connection of Mobile DiskOnChip Plus and prevents the TrueFFS driver from identifying Mobile DiskOnChip Plus.

For further information on how to connect Mobile DiskOnChip Plus to support CPUs that use the Big Endian system, refer to the application note for the relevant CPU.

9.5.3 Busy Signal

The Busy signal (BUSY#) indicates that Mobile DiskOnChip Plus has not yet completed internal initialization. After reset, BUSY# is asserted while the IPL is downloaded into the internal boot block and the Data Protection Structures (DPS) are downloaded to the Protection State Machines. After the download process is completed, BUSY# is negated. It can be used to delay the first access to Mobile DiskOnChip Plus until it is ready to accept valid cycles.

Note: The TrueFFS driver does NOT use this signal to indicate that the flash is in busy state (e.g. program, read, or erase).

9.5.4 Working with 8/16/32-Bit Systems with a Standard Interface

When using a standard interface, Mobile DiskOnChip Plus can be configured for 8-bit, 16-bit or 32-bit bus operations.

8-Bit (Byte) Data Access Mode

When configured for 8-bit operation, IF_CFG should be negated. Data should then be driven only on the low data bus signals D[7:0]. D[15:8] and BHE# are internally pulled up and may be left floating.

16-Bit (Word) Data Access Mode

When configured for 16-bit operation, IF_CFG should be asserted. The following definition is compatible with 16-bit platforms using the BHE#/BLE# protocol:

- When the host BLE# signal asserts Mobile DiskOnChip Plus A0, data is valid on D[7:0].
- When the host BHE# signal asserts Mobile DiskOnChip Plus BHE#, data is valid on D[15:8].
- When both A[0] and BHE# are at logic 0, data is valid on D[15:0].

- No data is transferred when both BHE# and A0 are logic 1.
- 16-bit hosts that do not support byte transfers may hardwire the A0 and BHE# inputs to logic 0.

Table 4 shows the active data bus lanes in 16-bit configuration.

Table 4: Active Data Bus Lanes in 16-bit Configuration

Inputs		Data Bus Activity		Transfer Type
BHE#	A0	D[7:0]	D[15:8]	
0	0	✓	✓	Word
0	1		✓	Odd Byte
1	0	✓		Even Byte
1	1			No Operation

Note: Although Mobile DiskOnChip Plus 16/32MB uses 8-bit access to the internal flash, it can be connected to a 16-bit bus. The TrueFFS driver handles all the issues regarding routing data to and from Mobile DiskOnChip Plus. The Programmable Boot Block is accessed as a true 16-bit device. It responds with the appropriate data when the CPU issues either an 8-bit or 16-bit read cycle.

32-Bit (Word) Data Access Mode

In a 32-bit bus system that cannot execute byte- or word-aligned accesses, the system address lines SA0 and SA1 are always zero. Consecutive long-words (32-bit) are differentiated by SA2 toggling. Therefore, in 32-bit systems that support only 32-bit data access cycles, DiskOnChip A1 is connected to the first system address bit that toggles, i.e. SA2. DiskOnChip A0 is connected to VSS to configure it for 16-bit operation (see Table 4).

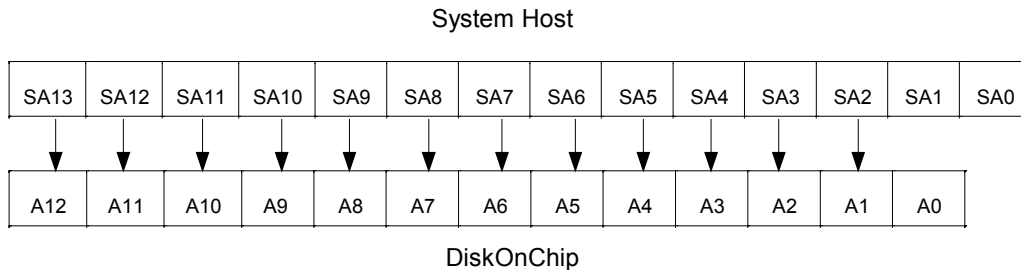

Figure 16: 32-Bit (Word) Data Access Mode

Note: The prefix “S” indicates system host address lines

TrueFFS Driver Modifications

TrueFFS supports a wide range of OSs (see Section 6.1.1). The TrueFFS driver is set to work in 8-bit data access mode as the default. To support 16-bit/32-bit data access modes and their related memory window allocations, TrueFFS must be modified. In Windows CE and Windows NT Embedded, these changes can be implemented through the Registry Entries. In all other cases, some minor customization is required in the driver. Please refer to the *readme* of each specific driver for further information.

9.6 Device Cascading

9.6.1 Standard Interface

When using a standard interface, up to four Mobile DiskOnChip Plus 16MB or up to two Mobile DiskOnChip Plus 32MB devices can be cascaded, for up to 64MB capacity. No external decoding circuitry or system redesign is required.

ID[1:0] ball values determine the identity of each device. Systems with only one device must configure it as device 0 by setting ID[1:0] to 00H. Additional devices should be configured as device 1, device 2 and device 3 by setting ID[1:0] to 01H, 10H and 11H, respectively.

Note: As Mobile DiskOnChip Plus 32MB is a dual die comprised of two internally stacked Mobile DiskOnChip Plus 16MB devices, only two Mobile DiskOnChip Plus 32MB devices may be cascaded. (Only ID0 is used).

When devices are cascaded, all I/O balls must be wired in common, including the BUSY# output. The ID input balls should be strapped to VCC or VSS, according to the location of each device. To communicate with a particular device, its ID must be written into the Device ID Select register (see Section 7.7). Only the device whose ID corresponds with this value responds to read or write cycles to registers.

Figure 17 illustrates the configuration required to cascade four devices on the host bus. Only the relevant cascading signals are included in this figure, although all other signals must also be connected.

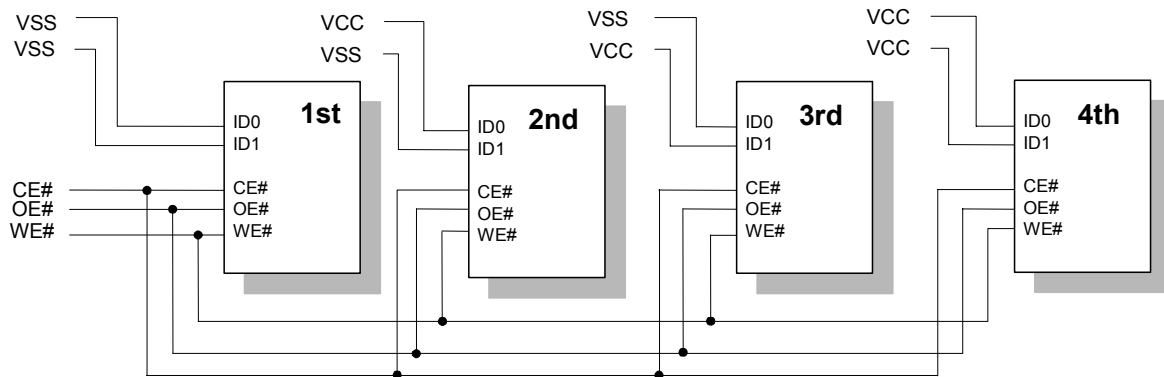

Figure 17: Cascading Configuration for Four Devices

9.6.2 Multiplexed Interface

When using a multiplexed interface, up to two Mobile DiskOnChip Plus 16MB devices can be cascaded, for up to 32MB capacity. No external decoding circuitry or system redesign is required.

The ID0 ball value determines the identity of each device. Systems with only one device must configure it as device 0 by connecting ID0 to VSS. The second device should be configured as device 1 by connecting ID0 to VCC.

When two devices are cascaded, all I/O balls must be wired in common, including the BUSY# output. To communicate with a particular device, its ID must be written into the Device ID Select register (see Section 7.7). Only the device whose ID corresponds with this value responds to read or write cycles to registers.

Note: Mobile DiskOnChip Plus 32MB devices cannot be cascaded in a multiplexed interface.

9.6.3 Memory Map in a Cascaded Configuration

When cascading Mobile DiskOnChip Plus devices, the Programmable Boot Block size is enlarged by 1KB for each additional 16MB device in the configuration. When four 16MB devices (or two 32MB devices) are connected in a cascaded configuration, a boot block size of 4KB is available.

The MAX_ID field of the Configuration register can be programmed with the maximum ID value used to enable access to the boot block of each device in a separate address space.

Initially at power-up, only device 0 responds to reads from the boot block address space with its 1KB of data aliased at addresses 0K, 1K, 6K and 7K. Figure 18 shows the memory map when the maximum number of devices are connected in a cascaded configuration, and the location of each IPL.

	Reset Mode		Normal Mode (after setting MAX_ID)
0000H	IPL 0	Section 0 Programmable Boot Block	IPL 0
	IPL 0		IPL 1
0800H	00H	Section 1	Flash Area Window
1000H	00H	Section 2	Control Registers
1800H	IPL 0	Section 3 Programmable Boot Block	IPL 2
	IPL 0		IPL 3

Figure 18: Memory Map in a Cascaded Configuration

10. Product Specifications

10.1 Environmental Specifications

10.1.1 Operating Temperature Ranges

Commercial Temperature Range: 0°C to 70°C

Extended Temperature Range: -40°C to +85°C

10.1.2 Thermal Characteristics

Table 5: Thermal Characteristics

Thermal Resistance (°C/W)	
Junction to Case (θ_{JC}): 30	Junction to Ambient (θ_{JA}): 85

10.1.3 Humidity

10% to 90% relative, non-condensing.

10.1.4 Endurance

Mobile DiskOnChip Plus is based on NAND flash technology, which guarantees a minimum of 300,000 erase cycles. Due to the TrueFFS wear-leveling algorithm, the life span of all DiskOnChip products is significantly prolonged. M-Systems' website (www.m-sys.com) provides an online life-span calculator to facilitate application-specific endurance calculations.

10.2 Disk Capacity

Table 6: Disk Capacity 16MB (in bytes)

DOS 6.22		VxWorks	
Formatted Capacity	Sectors	Formatted Capacity	Sectors
16,302,080	31,840	16,367,616	31,968

Table 7: Disk Capacity 32MB (in bytes)

DOS 6.22		VxWorks	
Formatted Capacity	Sectors	Formatted Capacity	Sectors
32,800,768	64,064	32,724,992	63,916

10.3 Electrical Specifications

10.3.1 Absolute Maximum Ratings

Table 8: Absolute Maximum Ratings

Parameter	Symbol	Rating ¹	Units	Notes
DC Core Supply Voltage	VCC	-0.6 to 4.6	V	
DC I/O Supply Voltage	VCCQ ³	-0.6 to 4.6	V	
Input Pin Voltage	V _{IN} ²	-0.6 to VCCQ+0.3, 4.6V max	V	
Input pin Current	I _{IN}	-10 to 10	mA	25 °C
Storage Temperature	T _{STG}	-55 to 150	°C	
Lead Temperature	T _{LEAD}	260	°C	10 sec
Maximum duration of applying VCCQ without VCC or VCC without VCCQ	T _{SUPPLY}	500	mS	See Note 3

1. Permanent device damage may occur if absolute maximum ratings are exceeded. Exposure to absolute maximum rating conditions for extended periods may affect device reliability.

2. The voltage on any pin may undershoot to -2.0 V or overshoot to 6.6V for less than 20 ns.

3. When operating DiskOnChip with separate power supplies for VCC and VCCQ, it is desirable to turn both supplies on and off simultaneously. Providing power separately (either at power-on or power-off) can cause excessive power dissipation. Damage to the device may result if this condition persists for more than 1 second.

10.3.2 Capacitance

Table 9: Capacitance (16MB)

Parameter	Symbol	Conditions	Min	Typ	Max	Unit
Input Capacitance	C _{IN}	V _{IN} = 0V			10	pF
Output Capacitance	C _{OUT}	V _{OUT} = 0V			10	pF

Capacitance is not 100% tested.

Table 10: Capacitance (32MB)

Parameter	Symbol	Conditions	Min	Typ	Max	Unit
Input Capacitance	C _{IN}	V _{IN} = 0V			20	pF
Output Capacitance	C _{OUT}	V _{OUT} = 0V			20	pF

Capacitance is not 100% tested.

10.3.3 DC Electrical Characteristics Over Operating Range

Table 11: DC Characteristics, 1.65V to 1.95V I/O

Parameter	Symbol	Conditions	Min	Typ	Max	Unit
Core Supply Voltage	VCC		2.5	3.3	3.6	V
I/O Supply Voltage	VCCQ		1.65	1.8	1.95	V
High-level Input Voltage	V _{IH}		VCCQ -0.4V			V
Low-level Input Voltage	V _{IL}				0.4	V
High-level Output Voltage	V _{OH}	I _{Oh} = -100 μA	VCCQ -0.1V			V
Low-level Output Voltage	V _{OL}	D[15:0] I _{ol} = 100 μA			0.1	V
		IRQ#, BUSY# 4 mA			0.3	
Input Leakage Current ^{1,2}	I _{ILK}				±10	μA
Output Leakage Current	I _{IOLK}				±10	μA
Active Supply Current ³	I _{CC}	Cycle Time = 100 ns (16MB)		25	45	mA
		Cycle Time = 100 ns (32MB)		50	90	
Standby Supply Current VCC Pins ⁴	I _{CCS}	Deep Power-Down mode ⁵ (16MB)		10	40	μA
		Deep Power-Down mode ⁵ (32MB)		20	80	
Standby Supply Current VCCQ Pins	I _{CCQS}	All inputs 0V or VCCQ 16MB		1.7	6	μA
		All inputs 0V or VCCQ 32MB		3.4	12	

1. The CE# input includes a pull-up resistor which sources 0.3~1.4 μA at Vin=0V

2. The D[15:8] and BHE# inputs each include a pull-up resistor which sources 58 ~ 234 μA at Vin = 0V when IF_CFG is a logic-0

3. VCC = 3.3V, VCCQ = 1.8V, Outputs open

4. If DiskOnChip is not set to Deep Power-Down mode and is not accessed for read/write operation, standby supply current is 400 μA (typ.) to 600 μA (max.)

5. Deep Power-Down mode is achieved by asserting RSTIN# (when in Normal mode) or writing the proper write sequence to the DiskOnChip registers, and asserting the CE# input = VCCQ. See Section 5.3 for further details.

Table 12: DC Characteristics, 2.5V-3.6 I/O

Parameter	Symbol	Conditions	Min	Typ	Max	Unit
Core Supply Voltage	VCC		2.5	3.3	3.6	V
I/O Supply Voltage	VCCQ		2.5	3.3	3.6	V
High-level Input Voltage	V _{IH}		2.1			V
Low-level Input Voltage	V _{IL}				0.7	V
High-level Output Voltage	V _{OH}	I _{OH} = I _{OHmax}	2.4			V
Low-level Output Voltage	V _{OL}	I _{OL} = I _{OLmax}			0.4	V
High-level Output Current	I _{OHMAX}	3.0V < VCCQ < 3.6V	-4			mA
		2.5V < VCCQ < 3.0V	-4			
Low-level Output Current	I _{OHMAX}	3.0V < VCCQ < 3.6V	8			mA
		2.5V < VCCQ < 3.0V	5			
Input Leakage Current ¹	I _{ILK}				±10	µA
Output Leakage Current	I _{IOLK}				±10	µA
Active Supply Current ³	I _{CC}	Cycle Time = 100 ns (16MB)		25	45	mA
		Cycle Time = 100 ns (32MB)		50	90	
Standby Supply Current VCC Pins ⁴	I _{CCS}	Deep Power-Down mode ⁵ (16MB)		10	40	µA
		Deep Power-Down mode ⁵ (32MB)		20	80	

1. The CE# input includes a pull-up resistor which sources 0.3~1.4 µA at Vin=0V

2. The D[15:8] and BHE# inputs each include a pull-up resistor which sources 58 ~ 234 µA at Vin = 0V when IF_CFG is a logic-0

3. VCC = VCCQ = 3.3V, Outputs open

4. If DiskOnChip is not set to Deep Power-Down mode and is not accessed for read/write operation, standby supply current is 400 µA (typ.) to 600 µA (max.)

5. Deep Power-Down mode is achieved by asserting RSTIN# (when in Normal mode) or writing the proper write sequence to the DiskOnChip registers, and asserting the CE# input = VCCQ. See Section 5.3 for further details.

10.3.4 AC Operating Conditions

Environmental and timing specifications are based on the following conditions.

Table 13: AC Test Conditions

Parameter	VCCQ=1.65 to 1.95V ¹	VCCQ=2.5-3.6V
Ambient Temperature (TA)	-40°C to +85°C	-40°C to +85°C
Supply Voltage	2.5V to 3.6V	2.5V to 3.6V
Input Pulse Levels	0.2V to VCCQ-0.2V	0V to 2.5V
Input Rise and Fall Times	3 ns	3 ns
Input Timing Levels	0.9V	1.5V
Output Timing Levels	0.9V	1.5V
Output Load	30 pF	100 pF

10.4 Timing Specifications

10.4.1 Read Cycle Timing Standard Interface

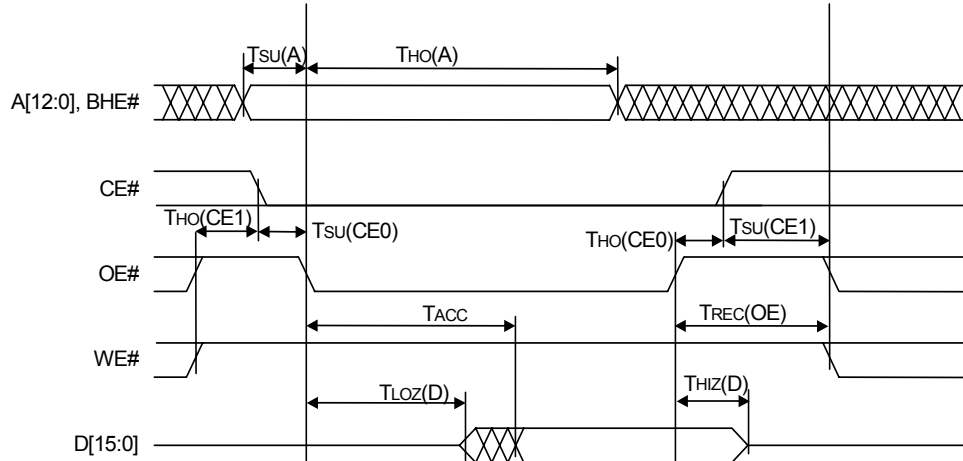

Figure 19: Standard Interface Read Cycle Timing

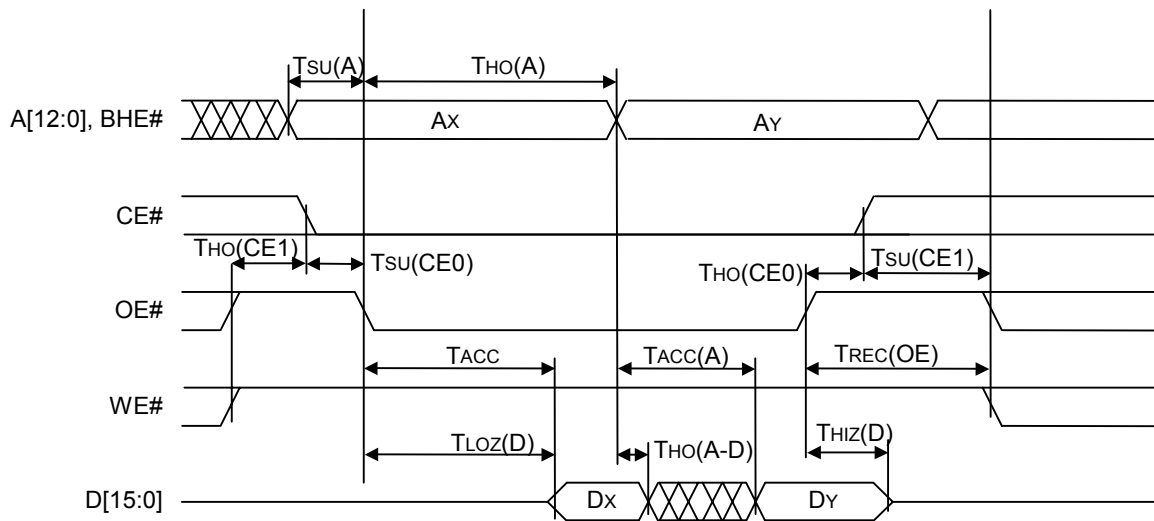

Figure 20: Standard Interface Read Cycle Timing – Asynchronous Boot Mode

Table 14: Standard Interface Read Cycle Timing Parameters (VCC=2.5-3.6V)

Symbol	Description	VCCQ=VCC VCC=2.5-3.6V		VCCQ=1.65-1.9V VCC=2.5-3.6V		Units
		Min	Max	Min	Max	
Tsu(A)	Address to OE# ↓ setup time	-2		-2		ns
Tho(A)	OE# ↓ to Address hold time	28		28		ns
Tsu(CE0)	CE# ↓ to OE# ↓ setup time ¹	—		—		ns
Tho(CE0)	OE# ↑ to CE# ↑ hold time ²	—		—		ns
Tho(CE1)	OE# or WE# ↑ to CE# ↓ hold time	6		6		ns
Tsu(CE1)	CE# ↑ to WE# ↓ or OE# ↓ setup time	6		6		ns
Trec(OE)	OE# negated to start of next cycle	20		20		ns
Tacc	Read access time (RAM) ^{3,4,5}		107		116	ns
	Read access time (all other addresses) ³		87		96	ns
Tloz(D)	OE# ↓ to D driven ⁶	15		15		ns
Thiz(D)	OE# ↑ to D Hi-Z delay		23		27	ns
Asynchronous Boot Mode						
tacc(A)	RAM Read access time from A[9:1]		93		101	ns
tho(A-D)	Data hold time from A[9:1] (RAM)	0		0		ns

Note: When designing your board to support DiskOnChip Plus 32MB or 64MB devices, it is not possible to use VCC=2.5-3.6V, as these devices only support VCC=2.7-3.6V.

Table 15: Standard Interface Read Cycle Timing Parameters (VCC=2.7-3.6V)

Symbol	Description	VCCQ=VCC VCC=2.7-3.6V		VCCQ=1.65-1.9V VCC=2.7-3.6V		Units
		Min	Max	Min	Max	
Tsu(A)	Address to OE# ↓ setup time	-2		-2		ns
Tho(A)	OE# ↓ to Address hold time	28		28		ns
Tsu(CE0)	CE# ↓ to OE# ↓ setup time ¹	—		—		ns
Tho(CE0)	OE# ↑ to CE# ↑ hold time ²	—		—		ns
Tho(CE1)	OE# or WE# ↑ to CE# ↓ hold time	6		6		ns
Tsu(CE1)	CE# ↑ to WE# ↓ or OE# ↓ setup time	6		6		ns
Trec(OE)	OE# negated to start of next cycle	20		20		ns
Tacc	Read access time (RAM) ^{3,4,5}		101		111	ns
	Read access time (all other addresses) ³		82		92	ns
Tloz(D)	OE# ↓ to D driven ⁶	15		15		ns
Thiz(D)	OE# ↑ to D Hi-Z delay		23		27	ns
Asynchronous Boot Mode						
tacc(A)	RAM Read access time from A[9:1]		89		98	ns
tho(A-D)	Data hold time from A[9:1] (RAM)	0		0		ns

1. CE# may be asserted any time before or after OE# is asserted. If CE# is asserted after OE#, all timing relative to when OE# was asserted will be referenced to the time CE# was asserted.

2. CE# may be negated any time before or after OE# is negated. If CE# is negated before OE#, all timing relative to when OE# was negated will be referenced to the time CE# was negated.

3. The boot block is located at addresses 0000~07FFH and 1800H~1FFFH. Registers located at addresses 0800H~17FFH have a faster access time than the boot block. Access to the boot block is not required after the boot process has completed.
4. Systems that do not access the boot block may implement only the read access timing for “all other registers”. This will increase the systems performance, however it will prevent access to the boot block.
5. Add 260 ns on the first read cycle when exiting Power-Down mode. See Section 5.3 for more information.
6. No load ($C_L = 0$ pF).

10.4.2 Write Cycle Timing Standard Interface

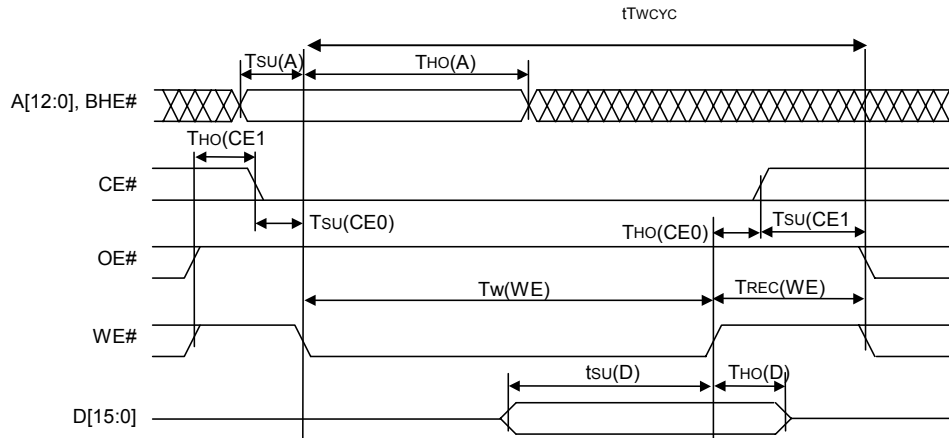

Figure 21: Standard Interface Write Cycle Timing

Table 16: Standard Interface Write Cycle Parameters (VCC=2.5-3.6V)

Symbol	Description	VCCQ=VCC VCC=2.5-3.6V		VCCQ=1.65-1.9V VCC=2.5-3.6V		Units
		Min	Max	Min	Max	
Tsu (A)	Address to WE# ↓ setup time	-2		-2		ns
Tho(A)	WE# ↓ to Address hold time	28		28		ns
Tw(WE)	WE# asserted width	50		49		ns
T _{wcyc}	Write Cycle Time	83		83		ns
Tsu (CE0)	CE# ↓ to WE# ↓ setup time ¹	--		--		ns
Tho (CE0)	WE# ↑ to CE# ↑ hold time ²	--		--		ns
Tho (CE1)	OE# or WE# ↑ to CE# ↓ hold time	6		6		ns
Tsu (CE1)	CE# ↑ to WE# ↓ or OE# ↓ setup time	6		6		ns
Trec (WE)	WE# ↑ to start of next cycle	20		20		ns
Tsu(D)	D to WE# ↑ setup time	29		29		ns
Tho (D)	WE# ↑ to D hold time	0		0		

Note: When designing your board to support also DiskOnChip Plus 32MB or 64MB devices, it is not possible to use VCC=2.5-3.6V, as these devices only support VCC=2.7-3.6V.

Table 17: Standard Interface Write Cycle Parameters ($V_{CC}=2.7V-3.6V$)

Symbol	Description	VCCQ=VCC VCC=2.7-3.6V		VCCQ=1.65-1.9V VCC=2.7-3.6V		Units
		Min	Max	Min	Max	
Tsu (A)	Address to WE# ↓ setup time	-2		-2		ns
Tho(A)	WE# ↓ to Address hold time	28		28		ns
Tw(WE)	WE# asserted width	49		48		ns
T _{WCYC}	Write Cycle Time	79		79		ns
Tsu (CE0)	CE# ↓ to WE# ↓ setup time ¹	--		--		ns
Tho (CE0)	WE# ↑ to CE# ↑ hold time ²	--		--		ns
Tho (CE1)	OE# or WE# ↑ to CE# ↓ hold time	6		6		ns
Tsu (CE1)	CE# ↑ to WE# ↓ or OE# ↓ setup time	6		6		ns
Trec (WE)	WE# ↑ to start of next cycle	20		20		ns
Tsu(D)	D to WE# ↑ setup time	27		28		ns
Tho (D)	WE# ↑ to D hold time	0		0		

1. CE# may be asserted any time before or after WE# is asserted. If CE# is asserted after WE#, all timing relative to WE# asserted should be referenced to the time CE# was asserted.

2. CE# may be negated any time before or after WE# is negated. If CE# is negated before WE#, all timing relative to WE# negated will be referenced to the time CE# was negated.

10.4.3 Read Cycle Timing Multiplexed Interface

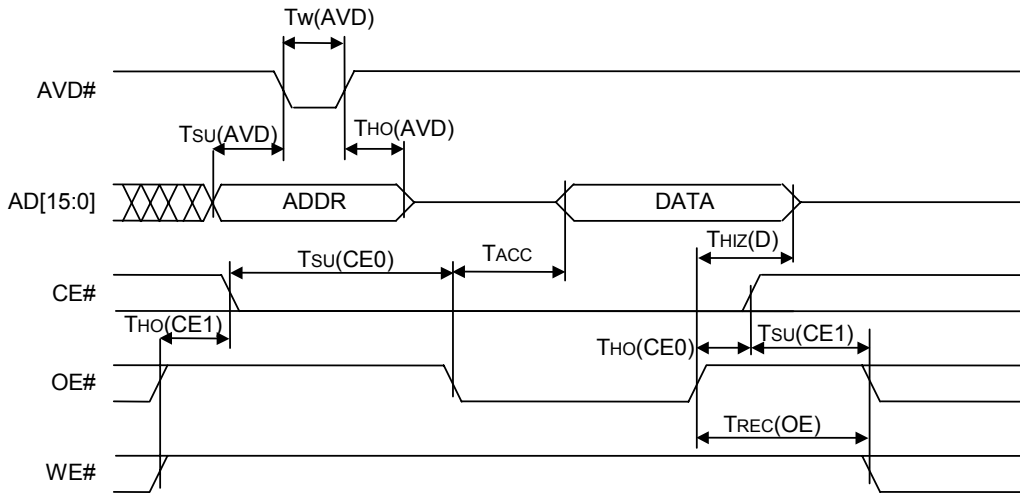

Figure 22: Multiplexed Interface Read Cycle Timing

Table 18: Multiplexed Interface Read Cycle Parameters (VCC 2.5-3.6V)

Symbol	Description	VCCQ=VCC VCC=2.5-3.6V		VCCQ=1.65-1.9V VCC=2.5-3.6V		Units
		Min	Max	Min	Max	
tsu(AVD)	Address to AVD# ↓ setup time	5		5		ns
tho(AVD)	Address to AVD# ↑ hold time	7		7		ns
Tw(AVD)	AVD# low pulse width	12		12		ns
tsu(CE0) ¹	CE# ↓ to OE# ↓ setup time ¹	—		—		
tho(CE0) ²	OE# ↑ to CE# ↑ hold time ²	—		—		ns
tho(CE1)	OE# or WE# ↑ to CE# ↓ hold time	6		6		ns
tsu(CE1)	CE# ↑ to WE# ↓ or OE# ↓ setup time	6		6		ns
trec(OE)	OE# negated to start of next cycle	20		20		ns
Tacc	Read access time (RAM)		107		116	ns
	Read access time (all other addresses)		87		96	
tloz(D) ³	OE# ↓ to D driven	15		15		ns
Thiz(D)	OE# ↑ to D Hi-Z delay		23		27	ns

Note: When designing your board to support also DiskOnChip Plus 32MB or 64MB devices, it is not possible to use VCC=2.5-3.6V, as these devices only support VCC=2.7-3.6V.

Table 19: Multiplexed Interface Read Cycle Parameters ($V_{CC}=2.7V-3.6V$)

Symbol	Description	$V_{CCQ}=V_{CC}$ $V_{CC}=2.7-3.6V$		$V_{CCQ}=1.65-1.9V$ $V_{CC}=2.7-3.6V$		Units
		Min	Max	Min	Max	
tsu(AVD)	Address to AVD# ↓ setup time	5		5		ns
tho(AVD)	Address to AVD# ↑ hold time	7		7		ns
Tw(AVD)	AVD# low pulse width	12		12		ns
tsu(CE0) ¹	CE# ↓ to OE# ↓ setup time ¹	—		—		
tho(CE0) ²	OE# ↑ to CE# ↑ hold time ²	—		—		ns
tho(CE1)	OE# or WE# ↑ to CE# ↓ hold time	6		6		ns
tsu(CE1)	CE# ↑ to WE# ↓ or OE# ↓ setup time	6		6		ns
trec(OE)	OE# negated to start of next cycle	20		20		ns
Tacc	Read access time (RAM)		101		111	ns
	Read access time (all other addresses)		82		92	
tloz(D) ³	OE# ↓ to D driven	15		15		ns
Thiz(D)	OE# ↑ to D Hi-Z delay		23		27	ns

1. CE# may be asserted any time before or after OE# is asserted. If CE# is asserted after OE#, all timing relative to OE# asserted will be referenced instead to the time of CE# asserted.

2. CE# may be negated any time before or after OE# is negated. If CE# is negated before OE#, all timing relative to OE# negated will be referenced instead to the time of CE# negated.

3. No load ($C_L = 0$ pF).

10.4.4 Write Cycle Timing Multiplexed Interface

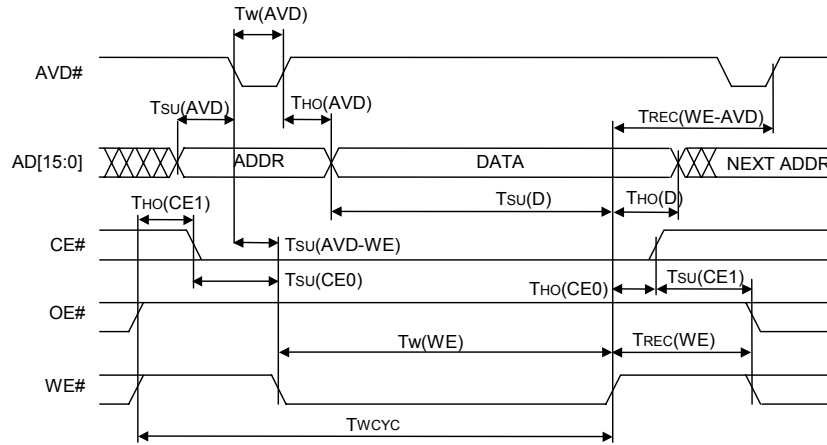

Figure 23: Multiplexed Interface Write Cycle Timing

Table 20: Multiplexed Interface Write Cycle Parameters (VCC=2.5V-3.6V)

Symbol	Description	VCCQ=VCC VCC=2.5-3.6V		VCCQ=1.65-1.9V VCC=2.5-3.6V		Units
		Min	Max	Min	Max	
tsu(AVD)	Address to AVD# ↓ setup time	5		5		ns
tho(AVD)	Address to AVD# ↑ hold time	7		7		ns
Tw(AVD)	AVD# low pulse width	12		12		ns
tsu(AVD-WE) ¹	AVD# ↓ to WE# ↓ setup time	4		4		
Trec(WE-AVD)	WE# ↑ to AVD# ↑ in next cycle	29		30		ns
tw(WE)	WE# asserted width (RAM) ³	51		50		ns
	WE# asserted width (all other addresses)	50		49		
Twcyc	Write Cycle Time	83		83		ns
tsu(CE0) ¹	CE# ↓ to WE# ↓ setup time	—		—		ns
tho(CE0) ²	WE# ↑ to CE# ↑ hold time	—		—		ns
tho(CE1)	OE# or WE# ↑ to CE# ↓ hold time	6		6		ns
tsu(CE1)	CE# ↑ to WE# ↓ or OE# ↓ setup time	6		6		ns
trec(WE)	WE# ↑ to start of next cycle	20		20		ns
Tsu(D)	D to WE# ↑ setup time (RAM)	29		29		ns
Tho(D)	WE# ↑ to D hold time	0		0		ns

Note: When designing your board to support also DiskOnChip Plus 32MB or 64MB devices, it is not possible to use VCC=2.5-3.6V, as these devices only support VCC=2.7-3.6V.

Table 21: Multiplexed Interface Write Cycle Parameters (VCC=2.7-3.6V)

Symbol	Description	VCCQ=VCC VCC=2.7-3.6V		VCCQ=1.65-1.9V VCC=2.7-3.6V		Units
		Min	Max	Min	Max	
tsu(AVD)	Address to AVD# ↓ setup time	5		5		ns
tho(AVD)	Address to AVD# ↑ hold time	7		7		ns
Tw(AVD)	AVD# low pulse width	12		12		ns
tsu(AVD-WE) ¹	AVD# ↓ to WE# ↓ setup time	4		4		
Trec(WE-AVD)	WE# ↑ to AVD# ↑ in next cycle	28		30		ns
tw(WE)	WE# asserted width (RAM) ³	48		47		ns
	WE# asserted width (all other addresses)	49		48		
Twcyc	Write Cycle Time	79		79		ns
tsu(CE0) ¹	CE# ↓ to WE# ↓ setup time	—		—		ns
tho(CE0) ²	WE# ↑ to CE# ↑ hold time	—		—		ns
tho(CE1)	OE# or WE# ↑ to CE# ↓ hold time	6		6		ns
tsu(CE1)	CE# ↑ to WE# ↓ or OE# ↓ setup time	6		6		ns
trec(WE)	WE# ↑ to start of next cycle	20		20		ns
Tsu(D)	D to WE# ↑ setup time (RAM)	27		28		ns
Tho(D)	WE# ↑ to D hold time	0		0		ns

1. CE# may be asserted any time before or after WE# is asserted. If CE# is asserted after WE#, all timing relative to WE# asserted will be referenced instead to the time of CE# asserted.

2. CE# may be negated any time before or after WE# is negated. If CE# is negated before WE#, all timing relative to WE# negated will be referenced instead to the time of CE# negated.

3. WE# may be asserted before or after the rising edge of AVD#. The beginning of the WE# asserted pulse width spec is measured from the later of the falling edge of WE# or the rising edge of AVD#.

10.4.5 Power-Up Timing

Mobile DiskOnChip Plus is reset by assertion of the RSTIN# input. When this signal is negated, DiskOnChip initiates a download procedure from the flash memory into the internal Programmable Boot Block. During this procedure, Mobile DiskOnChip Plus does not respond to read or write accesses.

Host systems must therefore observe the requirements described below for first access to Mobile DiskOnChip Plus. Any of the following methods may be employed to guarantee first-access timing requirements:

- Use a software loop to wait at least T_p (BUSY1) before accessing the device after the reset signal is negated.
- Poll the state of the BUSY# output.
- Use the BUSY# output to hold the host CPU in wait state before completing the first access.

Host systems that boot from Mobile DiskOnChip Plus must employ option c), or use another method to guarantee the required timing for first-time access.

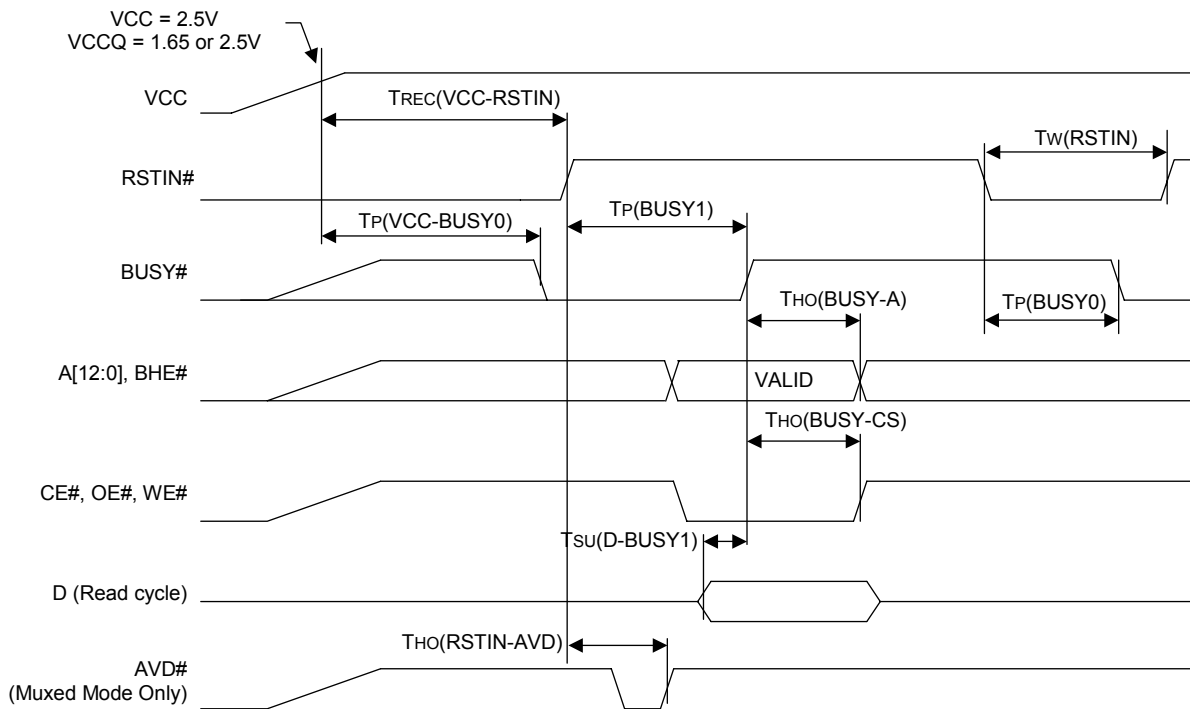

Figure 24: Reset Timing

Table 22: Power-Up Timing Parameters

Symbol	Description	Min	Max	Units
T _{REC} (VCC-RSTIN) ¹	VCC/VCCQ stable to RSTIN# ↑	500		μs
T _p (VCC-BUSY0) ¹	VCC/VCCQ stable to BUSY# ↓		500	μs
T _w (RSTIN)	RSTIN# asserted pulse width	30		ns
T _p (BUSY0)	RSTIN# ↓ to BUSY# ↓		50	ns
T _p (BUSY1) ²	RSTIN# ↑ to BUSY# ↑		1.3	ms
T _{HO} (BUSY-CE) ³	BUSY# ↑ to CE# ↑	0		ns
T _{SU} (D-BUSY1) ³	Data valid to BUSY# ↑	0		ns
T _{ho} (RSTIN-AVD) ⁴	RSTIN# ↑ to AVD# low hold	70		ns

1. Specified from the final positive crossing of Vcc above 2.5V and VCCQ above 1.65 or 2.5V.
2. If the assertion of RSTIN# occurs during a flash erase cycle, this time could be extended by up to 500 μs.
3. Normal read/write cycle timing applies. This parameter applies only when the cycle is extended until the negation of the BUSY# signal.
4. Applies to multiplexed interface only.
5. When operating DiskOnChip with separate power supplies for VCC and VCCQ, it is recommended to turn both power supplies on and off simultaneously. Providing power separately (either at power-on or power-off) can cause excessive power dissipation. Damage to the device may result if this condition persists for more than 1 second.

10.4.6 Interrupt Timing

The interrupt timing is illustrated in Figure 25, and described in Table 23.

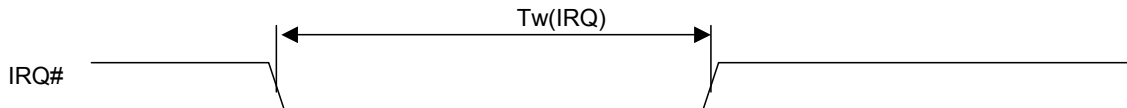

Figure 25: IRQ# Pulse Width in Edge Mode

Table 23: Interrupt Timing

Symbol	Description	Min	Max	Units
T _w (IRQ)	IRQ# asserted pulse width (edge mode)	300	800	nS

10.5 Mechanical Dimensions

See Figure 26 for the mechanical dimensions of the FBGA package.

FBGA Dimensions (16MB): 9.0 ± 0.20 mm x 12.0 ± 0.20 mm x 1.2 ± 0.1 mm

FBGA Dimensions (32MB): 9.0 ± 0.20 mm x 12.0 ± 0.20 mm x 1.4 ± 0.1 mm

Ball Pitch: 0.8mm

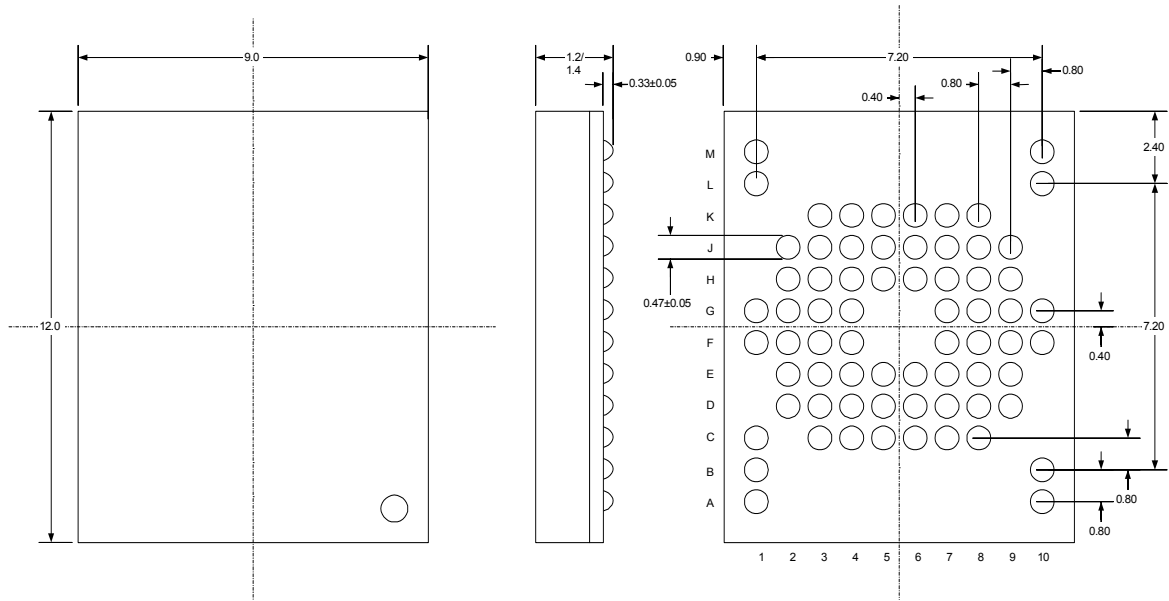

Figure 26: Mechanical Dimensions of the FBGA Package

11. Ordering Information

MD3x31-Dxx-V3Q18-T-C

MD: M-Systems DiskOnChip	MD3831 – Mobile DiskOnChip Plus FBGA MD3331 – Mobile DiskOnChip Plus dual-die FBGA
D: Capacity	16, 32 Capacity: 32MB (256Mb) or 16MB (128Mb)
V: Voltage	V3Q18 Core Voltage: 3.3V, I/O Voltage: 1.8 or 3.3V
T: Temperature Range	Blank Commercial: 0°C to +70°C X Extended: –40°C to +85°C
C: Composition	Blank Regular P Lead-free

Summary of available configurations:

Table 24: Available Mobile DiskOnChip Plus Configurations

Capacity	Package	Temperature Range ¹	Type	Order Information	
16 MByte (128 Mbit)	9x12 mm FBGA	Commercial	Regular	MD3831-D16-V3Q18	
		Extended	Regular	MD3831-D16-V3Q18-X	
		Commercial	Lead-free	MD3831-D16-V3Q18-P	
		Extended	Lead-free	MD3831-D16-V3Q18-X-P	
32 MByte (256 Mbit)		Commercial	Regular	MD3331-D32-V3Q18	
		Extended	Regular	MD3331-D32-V3Q18-X	
		Commercial	Lead-free	MD3331-D32-V3Q18-P	
		Extended	Lead-free	MD3331-D32-V3Q18-X-P	
N/A		N/A	N/A	Daisy-Chain	MD3831-D00-DAISY

How to Contact Us

Internet: <http://www.m-sys.com>

General Information: info@m-sys.com

Sales and Technical Information: techsupport@m-sys.com

USA

M-Systems Inc.
8371 Central Ave, Suite A
Newark CA 94560
Phone: +1-510-494-2090
Fax: +1-510-494-5545

Taiwan

M-Systems Asia Ltd.
Room B, 13 F, No. 133 Sec. 3
Min Sheng East Road
Taipei, Taiwan
R.O.C.
Tel: +886-2-8770-6226
Fax: +886-2-8770-6295

Japan

Asahi Seimei Gotanda Bldg., 3F
5-25-16 Higashi-Gotanda
Shinagawa-ku Tokyo, 141-0022
Tel: +81-3-5423-8101
Fax: +81-3-5423-8102

China

M-Systems China Ltd.
25A International Business Commercial Bldg.
Nanhu Rd., Lou Hu District
Shenzhen, China 518001
Phone: +86-755-2519-4732
Fax: +86-755-2519-4729

Europe

M-Systems Ltd.
7 Atir Yeda St.
Kfar Saba 44425, Israel
Tel: +972-9-764-5000
Fax: +972-3-548-8666

© 2003 M-Systems Flash Disk Pioneers, Ltd. All rights reserved.

This document is for information use only and is subject to change without prior notice. M-Systems Flash Disk Pioneers Ltd. assumes no responsibility for any errors that may appear in this document. No part of this document may be reproduced, transmitted, transcribed, stored in a retrievable manner or translated into any language or computer language, in any form or by any means, electronic, mechanical, magnetic, optical, chemical, manual or otherwise, without prior written consent of M-Systems.

M-Systems products are not warranted to operate without failure. Accordingly, in any use of the Product in life support systems or other applications where failure could cause injury or loss of life, the Product should only be incorporated in systems designed with appropriate and sufficient redundancy or backup features.

Contact your local M-Systems sales office or distributor, or visit our website at www.m-sys.com to obtain the latest specifications before placing your order.

DiskOnChip[®], DiskOnChip Millennium[®], DiskOnKey[®] and TrueFFS[®] are registered trademarks of M-Systems. FFD[™] and SuperMAP[™] are trademarks of M-Systems. Other product names mentioned in this document may be trademarks or registered trademarks of their respective owners and are hereby acknowledged.