

# DATA SHEET

## **BFG10W/X** UHF power transistor

Product specification  
File under Discrete Semiconductors, SC14

1995 Sep 22

## UHF power transistor

## BFG10W/X

## FEATURES

- High efficiency
- Small size discrete power amplifier
- 900 MHz and 1.9 GHz operating areas
- Gold metallization ensures excellent reliability.

## APPLICATIONS

- Common emitter class-AB operation in hand-held radio equipment up to 1.9 GHz.

## DESCRIPTION

NPN silicon planar epitaxial transistor encapsulated in a plastic, 4-pin dual-emitter SOT343 package.

## PINNING

PIN	DESCRIPTION
1	collector
2	emitter
3	base
4	emitter

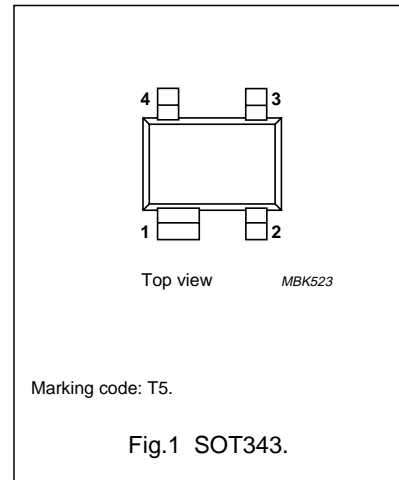

## QUICK REFERENCE DATA

RF performance at  $T_{amb} = 25\text{ °C}$  in a common-emitter test circuit.

MODE OF OPERATION	f (GHz)	$V_{CE}$ (V)	$P_L$ (mW)	$G_p$ (dB)	$\eta_c$ (%)
Pulsed, class-AB, duty cycle: < 1 : 2; $t_p = 10\text{ ms}$	1.9	3.6	200	$\geq 5$	$\geq 50$
Pulsed, class-AB, duty cycle: < 1 : 8; $t_p = 4.6\text{ ms}$	0.9	6	650	$\geq 10$	$\geq 50$
	0.9	6	360	$\geq 12.5$	$\geq 50$

## LIMITING VALUES

In accordance with the Absolute Maximum Rating System (IEC 134).

SYMBOL	PARAMETER	CONDITIONS	MIN.	MAX.	UNIT
$V_{CBO}$	collector-base voltage	open emitter	–	20	V
$V_{CEO}$	collector-emitter voltage	open base	–	10	V
$V_{EBO}$	emitter-base voltage	open collector	–	2.5	V
$I_C$	collector current (DC)		–	250	mA
$I_{C(AV)}$	average collector current		–	250	mA
$P_{tot}$	total power dissipation	up to $T_s = 102\text{ °C}$ ; note 1	–	400	mW
$T_{stg}$	storage temperature		–65	+150	°C
$T_j$	junction temperature		–	175	°C

## THERMAL CHARACTERISTICS

SYMBOL	PARAMETER	CONDITIONS	VALUE	UNIT
$R_{th\ j-s}$	thermal resistance from junction to soldering point	up to $T_s = 102\text{ °C}$ ; note 1; $P_{tot} = 400\text{ mW}$	180	K/W

## Note to the Limiting values and Thermal characteristics

1.  $T_s$  is the temperature at the soldering point of the collector pin.

UHF power transistor

BFG10W/X

**CHARACTERISTICS**

$T_j = 25\text{ }^\circ\text{C}$  (unless otherwise specified).

SYMBOL	PARAMETER	CONDITIONS	MIN.	MAX.	UNIT
$V_{(BR)CBO}$	collector-base breakdown voltage	open emitter; $I_C = 0.1\text{ mA}$	20	–	V
$V_{(BR)CEO}$	collector-emitter breakdown voltage	open base; $I_C = 5\text{ mA}$	10	–	V
$V_{(BR)EBO}$	emitter-base breakdown voltage	open collector; $I_E = 0.1\text{ mA}$	2.5	–	V
$I_{CES}$	collector cut-off current	$V_{CE} = 6\text{ V}; V_{BE} = 0$	–	100	$\mu\text{A}$
$h_{FE}$	DC current gain	$I_C = 50\text{ mA}; V_{CE} = 5\text{ V}$	25	–	
$C_C$	collector capacitance	$I_E = i_e = 0; V_{CB} = 6\text{ V}; f = 1\text{ MHz}$	–	3	pF
$C_{re}$	feedback capacitance	$I_C = 0; V_{CE} = 6\text{ V}; f = 1\text{ MHz}$	–	2	pF

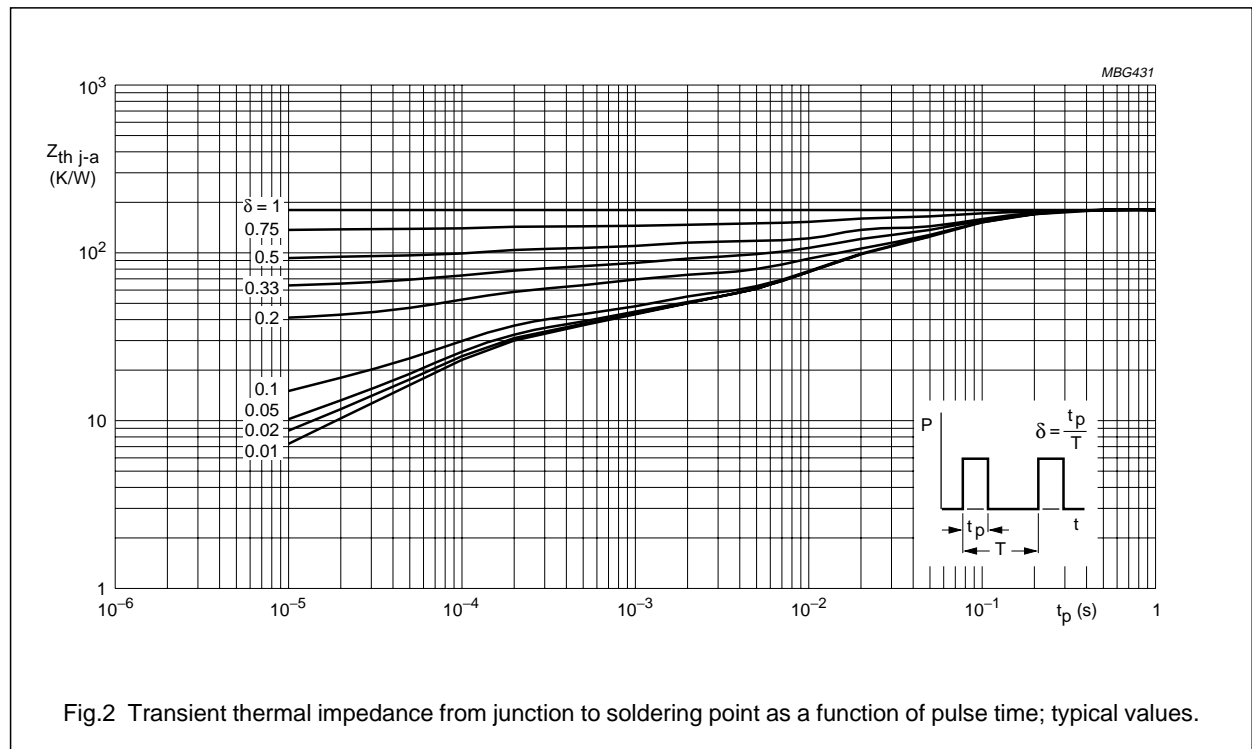

UHF power transistor

BFG10W/X

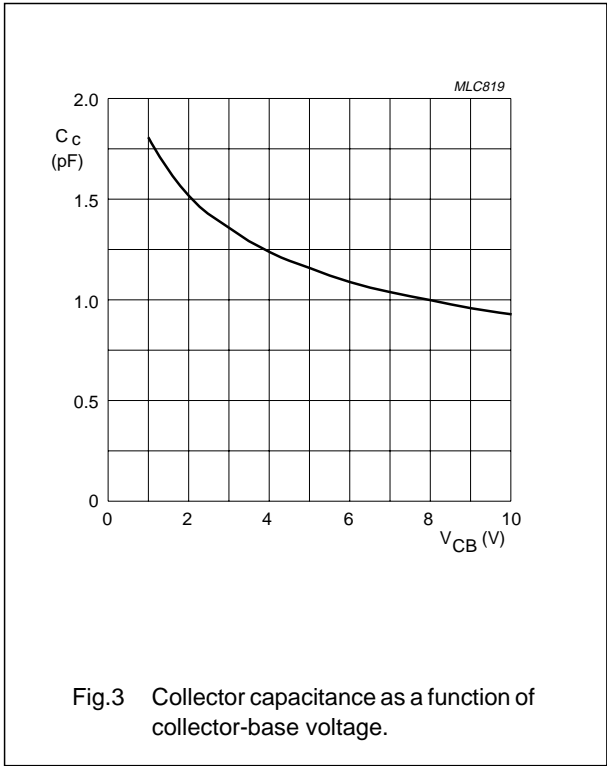

## UHF power transistor

## BFG10W/X

## APPLICATION INFORMATION

RF performance at  $T_{amb} = 25\text{ }^{\circ}\text{C}$  in a common-emitter test circuit.

MODE OF OPERATION	f (GHz)	$V_{CE}$ (V)	$P_L$ (mW)	$G_p$ (dB)	$\eta_c$ (%)
Pulsed, class-AB, duty cycle: < 1 : 2; $t_p = 10\text{ ms}$	1.9	3.6	200	$\geq 5$ ; typ. 7	$\geq 50$ ; typ. 60
Pulsed, class-AB, duty cycle: < 1 : 8; $t_p = 5\text{ ms}$	0.9	6	650	$\geq 10$	$\geq 50$
	0.9	6	360	$\geq 12.5$	$\geq 50$

## Ruggedness in class-AB operation

The BFG10W/X is capable of withstanding a load mismatch corresponding to  $VSWR = 6 : 1$  through all phases under pulsed conditions up to a supply voltage of 8.6 V under the conditions: 900 MHz; 650 mW;  $t_p = 4.6\text{ ms}$ ; duty cycle of 1 : 8 and up to a supply voltage of 5.5 V under the conditions: 1.9 GHz; 200 mW;  $t_p = 10\text{ ms}$ ; duty cycle of 1 : 2.

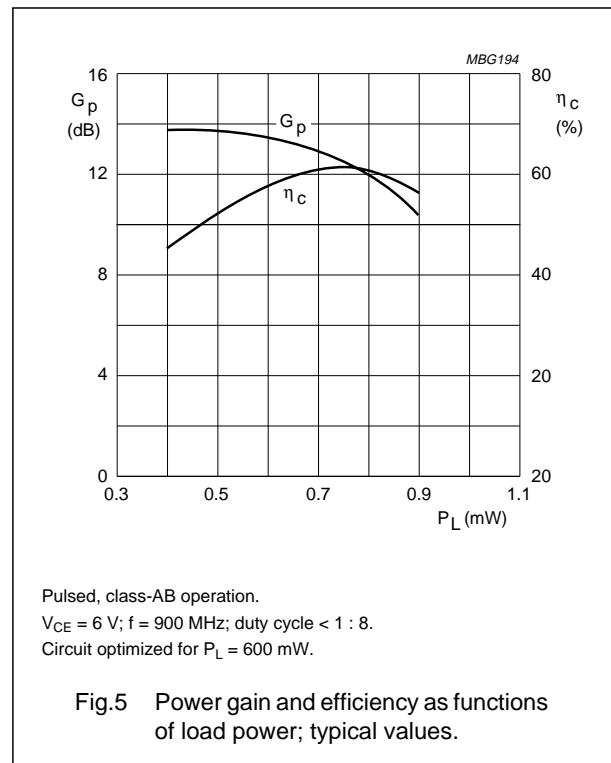
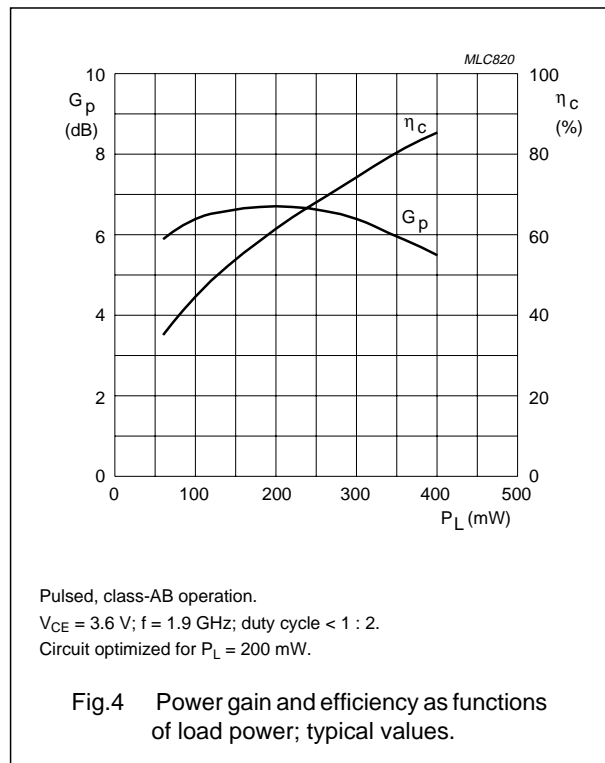

## UHF power transistor

BFG10W/X

## List of components (see Fig.6)

COMPONENT	DESCRIPTION	VALUE	DIMENSIONS	CATALOGUE No.
TR1	bias transistor, BC548 or equivalent	note 1		
C1, C4, C7	capacitor; notes 2 and 3	120 pF		
C2	capacitor; note 2	6.8 pF		
C3	capacitor; note 2	0.5 pF		
C5	capacitor; note 2	1.2 pF		
C6	capacitor; note 2	1.9 pF		
C8	Philips multilayer capacitor	1 nF, 10 V		
C9	Philips capacitor	1500 $\mu$ F, 10 V		2222 032 14152
L1	6 turns enamelled 0.7 mm copper wire		length 3.5 mm	
L4	2 turns enamelled 0.7 mm copper wire		length 3 mm	
L2, L3	RF choke, Philips			4312 020 36690
R1	metal film resistor	275 $\Omega$		
R2	metal film resistor	100 $\Omega$		
R3	metal film resistor	10 $\Omega$		

## Notes

1.  $V_{BE}$  at 1 mA must be 0.65 V.
2. American Technical Ceramics type 100A or capacitor of same quality.
3. Resonant at 1900 MHz.

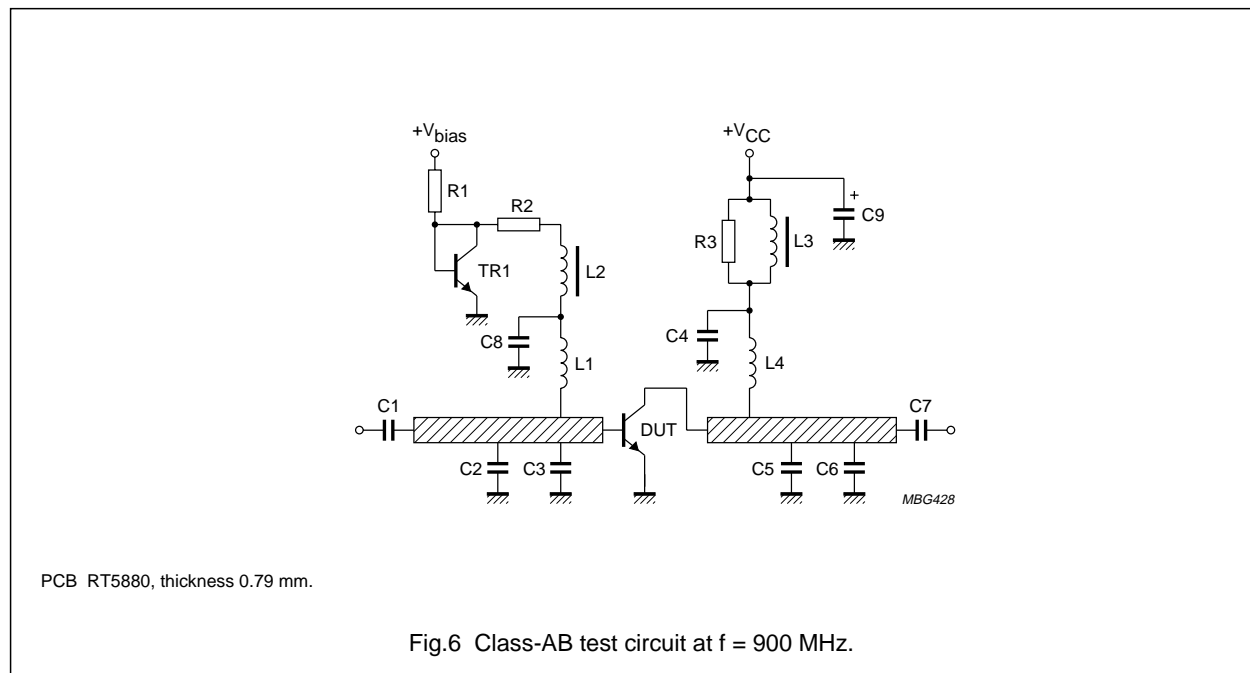

## UHF power transistor

BFG10W/X

## List of components (see Fig.7)

COMPONENT	DESCRIPTION	VALUE	DIMENSIONS	CATALOGUE No.
TR1	bias transistor, BC548 or equivalent	note 1		
C1, C6, C7, C8	capacitor; notes 2 and 3	24 pF		
C2	capacitor; note 2	0.4 pF		
C3	capacitor; note 2	2.4 pF		
C4	capacitor; note 2	0.5 pF		
C5	capacitor; note 2	1.2 pF		
C9, C10	Philips capacitor	1500 $\mu$ F, 10 V		2222 032 14152
L1, L2	RF choke, Philips			4330 030 36301
R1, R2	metal film resistor	75 $\Omega$		
R3, R4	metal film resistor	10 $\Omega$		

## Notes

- $V_{BE}$  at 1 mA must be 0.65 V.
- American Technical Ceramics type 100A or capacitor of same quality.
- Resonant at 1900 MHz.

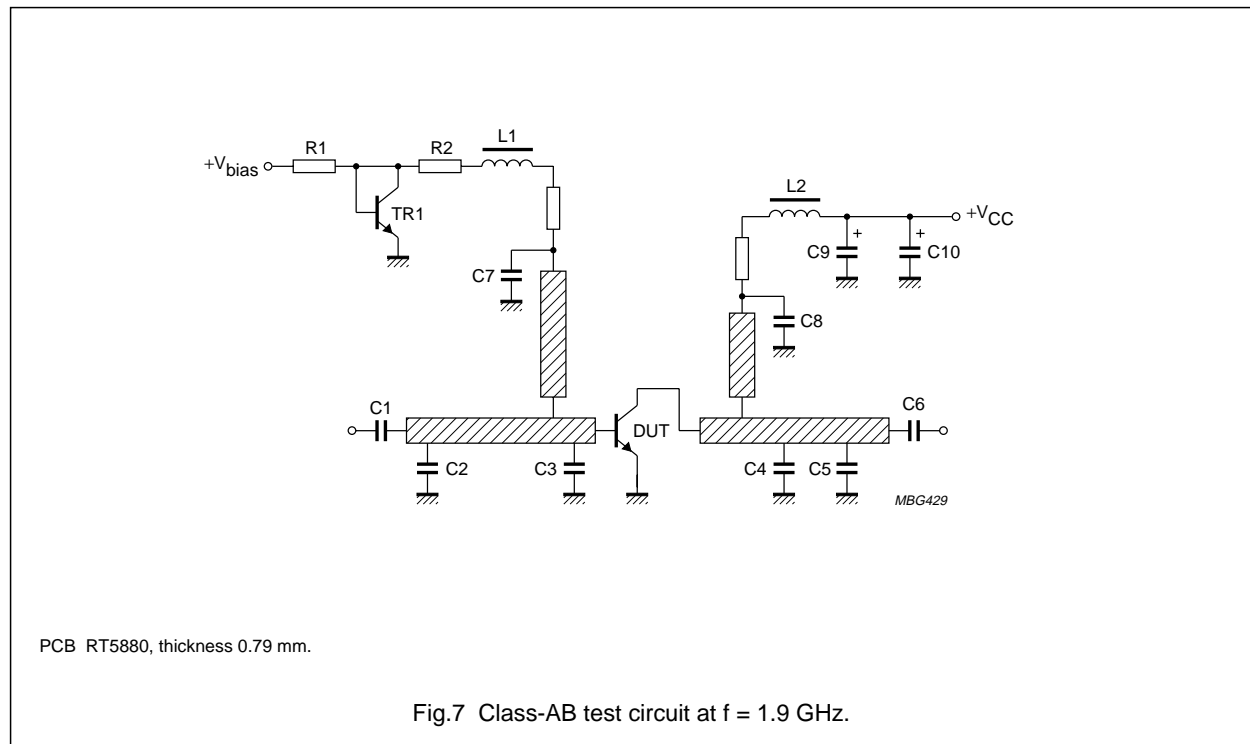

UHF power transistor

BFG10W/X

PACKAGE OUTLINE

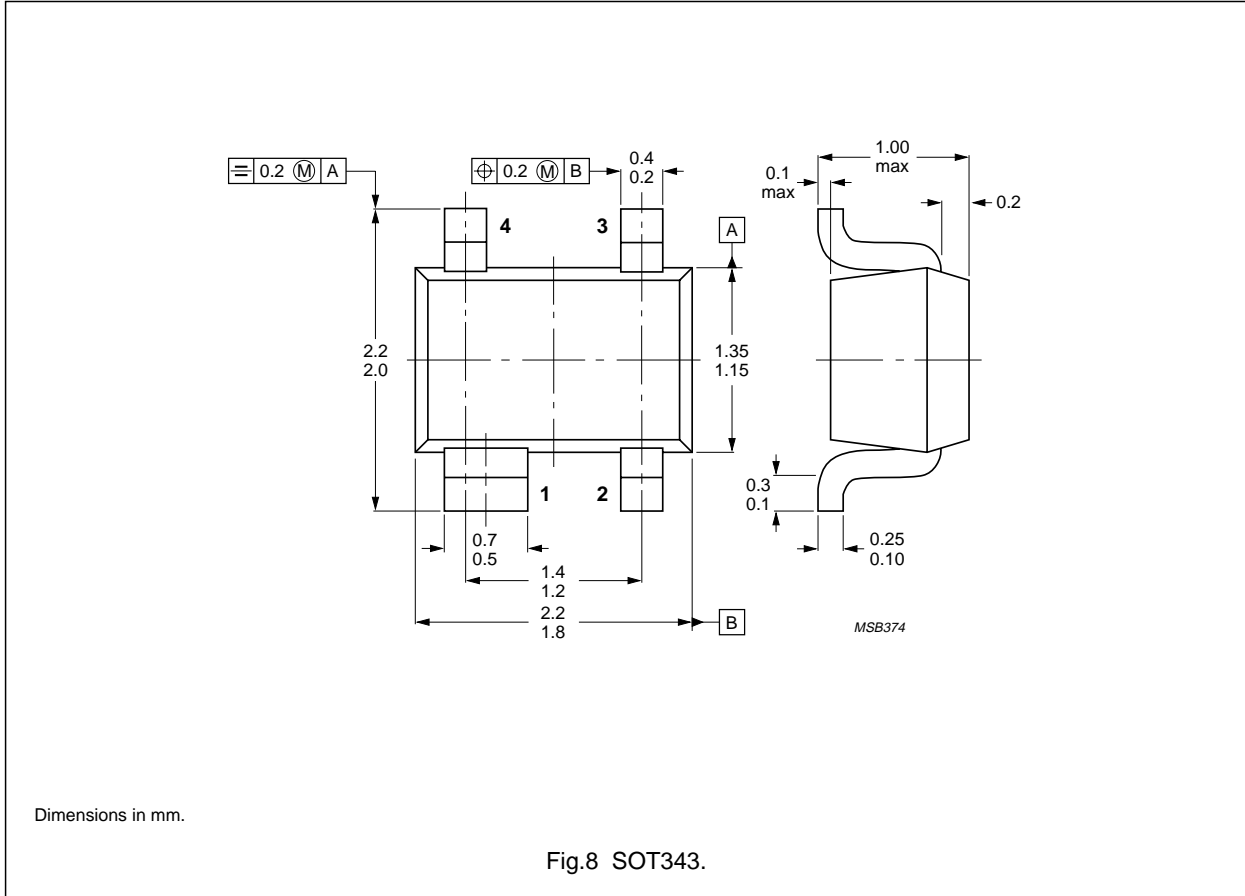



## UHF power transistor

BFG10W/X

**DEFINITIONS**

<b>Data Sheet Status</b>	
Objective specification	This data sheet contains target or goal specifications for product development.
Preliminary specification	This data sheet contains preliminary data; supplementary data may be published later.
Product specification	This data sheet contains final product specifications.
<b>Limiting values</b>	
Limiting values given are in accordance with the Absolute Maximum Rating System (IEC 134). Stress above one or more of the limiting values may cause permanent damage to the device. These are stress ratings only and operation of the device at these or at any other conditions above those given in the Characteristics sections of the specification is not implied. Exposure to limiting values for extended periods may affect device reliability.	
<b>Application information</b>	
Where application information is given, it is advisory and does not form part of the specification.	

**LIFE SUPPORT APPLICATIONS**

These products are not designed for use in life support appliances, devices, or systems where malfunction of these products can reasonably be expected to result in personal injury. Philips customers using or selling these products for use in such applications do so at their own risk and agree to fully indemnify Philips for any damages resulting from such improper use or sale.