

Silicon PNP Power Transistors

2SA980/981/982

DESCRIPTION

- With TO-3 package
- Complement to type 2SC2260/2261/2262

APPLICATIONS

- For power switching and general purpose applications

PINNING(see Fig.2)

PIN	DESCRIPTION
1	Base
2	Emitter
3	Collector

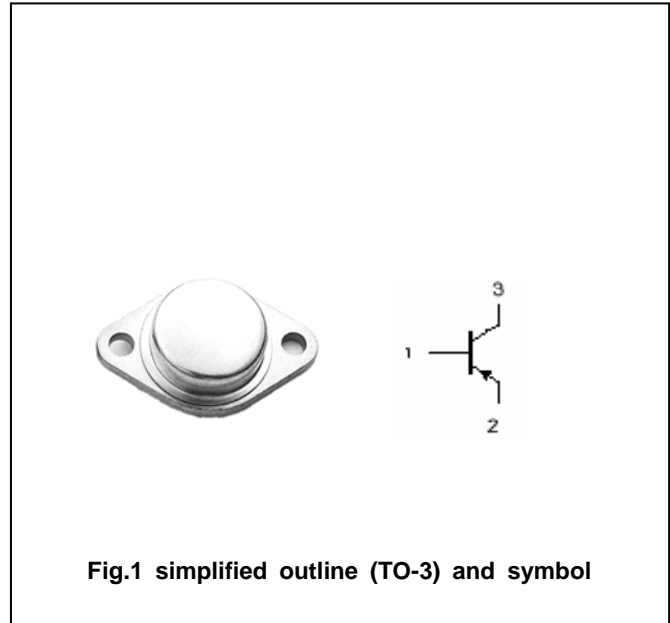

Fig.1 simplified outline (TO-3) and symbol

Absolute maximum ratings(Ta=℃)

SYMBOL	PARAMETER	CONDITIONS	VALUE	UNIT
V _{CBO}	Collector-base voltage	2SA980	-100	V
		2SA981	-120	
		2SA982	-140	
V _{CEO}	Collector-emitter voltage	2SA980	-100	V
		2SA981	-120	
		2SA982	-140	
V _{EBO}	Emitter-base voltage	Open collector	-6	V
I _C	Collector current		-8	A
I _B	Base current		-3	A
P _C	Collector power dissipation	T _C =25℃	80	W
T _j	Junction temperature		150	℃
T _{stg}	Storage temperature		-65~150	℃

Silicon PNP Power Transistors

2SA980/981/982

CHARACTERISTICS

T_j=25°C unless otherwise specified

SYMBOL	PARAMETER	CONDITIONS	MIN	TYP.	MAX	UNIT
V _{(BR)CEO}	Collector-emitter breakdown voltage	2SA980	-100			V
		2SA981	-120			
		2SA982	-140			
V _{CEsat}	Collector-emitter saturation voltage	I _C =-3A; I _B =-0.3A			-1.5	V
I _{CBO}	Collector cut-off current	2SA980				mA
		2SA981			-0.1	
		2SA982				
I _{EBO}	Emitter cut-off current	V _{EB} =-6V; I _C =0			-0.1	mA
h _{FE}	DC current gain	I _C =-3A; V _{CE} =-4V	30			
f _T	Transition frequency	I _C =-0.5A; V _{CE} =-12V		20		MHz

Switching times

t _r	Rise time			0.85		μs
t _s	Storage time	I _C =-3A; R _L =4 Ω I _{B1} =-0.2A; I _{B2} =0.1A V _{CC} =-12V		2.0		μs
t _f	Fall time			0.3		μs

PACKAGE OUTLINE

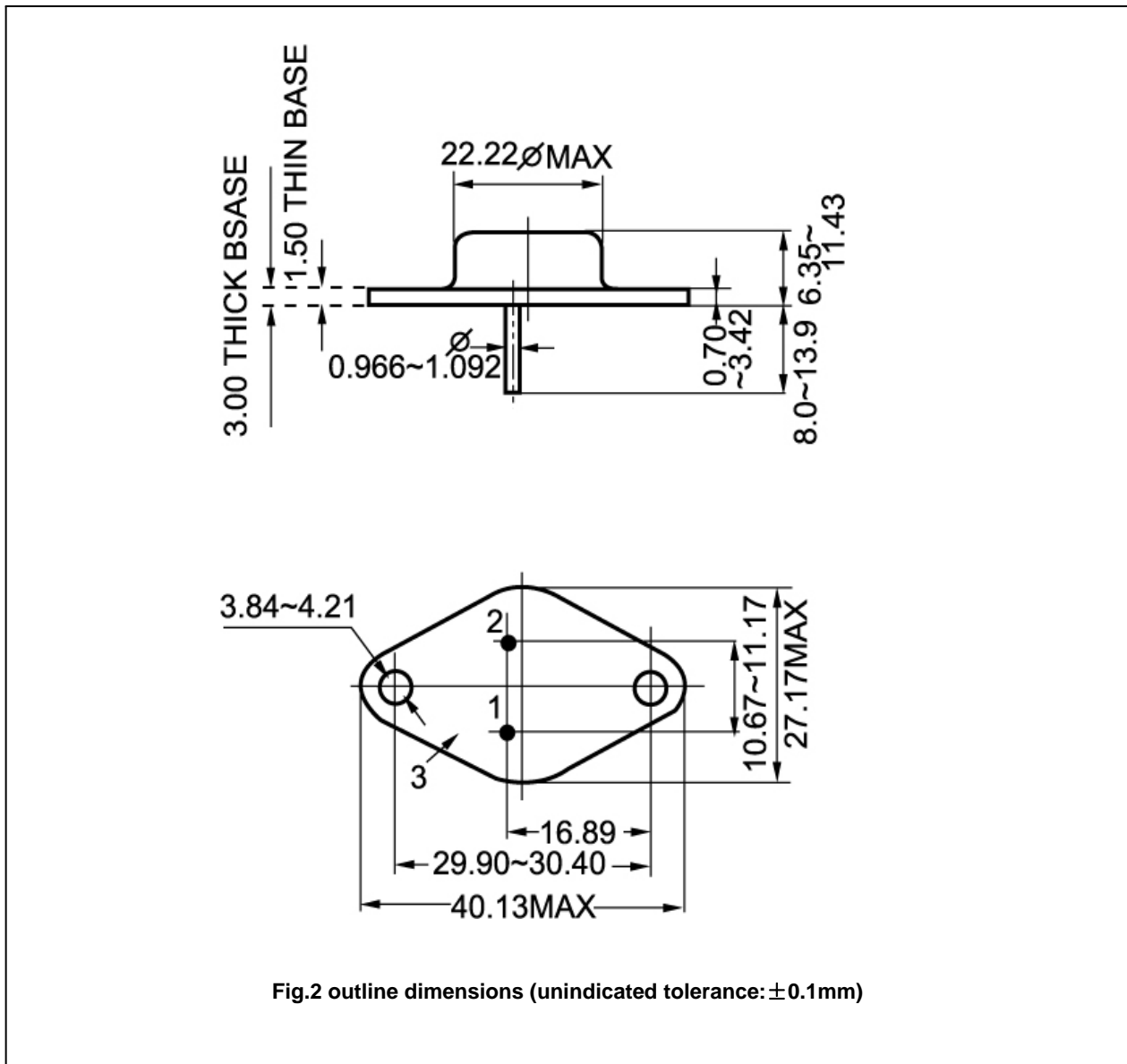

Fig.2 outline dimensions (unindicated tolerance: ± 0.1 mm)