

2SA2004

Silicon PNP epitaxial planer type

For power amplification

■ Features

- High forward current transfer ratio h_{FE}
- Satisfactory linearity of forward current transfer ratio h_{FE}
- Dielectric breakdown voltage of the package: > 5 kV
- High-speed switching

■ Absolute Maximum Ratings $T_C = 25^\circ\text{C}$

Parameter	Symbol	Rating	Unit
Collector to base voltage	V_{CBO}	-60	V
Collector to emitter voltage	V_{CEO}	-60	V
Emitter to base voltage	V_{EBO}	-5	V
Peak collector current	I_{CP}	-16	A
Collector current	I_C	-8	A
Collector power dissipation	P_C	$T_C = 25^\circ\text{C}$	20
		$T_a = 25^\circ\text{C}$	2.0
Junction temperature	T_j	150	$^\circ\text{C}$
Storage temperature	T_{stg}	-55 to +150	$^\circ\text{C}$

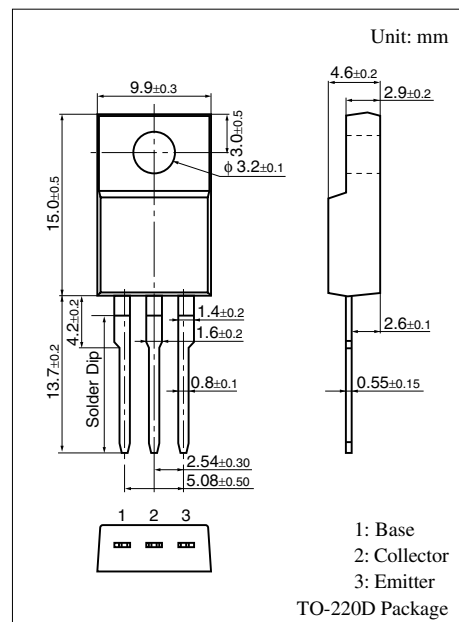

■ Electrical Characteristics $T_C = 25^\circ\text{C} \pm 3^\circ\text{C}$

Parameter	Symbol	Conditions	Min	Typ	Max	Unit
Collector cutoff current	I_{CBO}	$V_{CB} = -60\text{ V}, I_E = 0$			-100	μA
	I_{CEO}	$V_{CE} = -60\text{ V}, I_E = 0$			-100	μA
Collector to emitter voltage	V_{CEO}	$I_C = -10\text{ mA}, I_B = 0$	-60			V
Forward current transfer ratio	h_{FE1}	$V_{CE} = -2\text{ V}, I_C = -0.1\text{ A}$	100		230	
	h_{FE2}	$V_{CE} = -2\text{ V}, I_C = -5\text{ A}$	30			
Collector to emitter saturation voltage	$V_{CE(sat)}$	$I_C = -5\text{ A}, I_B = -0.25\text{ A}$			-1.2	V
Base to emitter saturation voltage	$V_{BE(sat)}$	$I_C = -5\text{ A}, I_B = -0.25\text{ A}$			-1.7	V
Turn-on time	t_{on}	$I_C = -4\text{ A}, I_{B1} = -400\text{ mA}$		0.2	0.5	μs
Storage time	t_{stg}	$I_{B2} = 400\text{ mA}, V_{CC} = 50\text{ V}$		0.1	0.15	μs
Fall time	t_f			0.5	1.0	μs