

SANYO	No.2972	2SA1669
		PNP Epitaxial Planar Silicon Transistor High-Frequency Amp Applications

Features

- High cutoff frequency : $f_T = 3.0\text{GHz typ}$
- High power gain : $\text{MAG} = 11\text{dB typ}$ ($f = 0.9\text{GHz}$)
- Small noise figure : $\text{NF} = 2.0\text{dB typ}$ ($f = 0.9\text{GHz}$)

Absolute Maximum Ratings at $T_a = 25^\circ\text{C}$

			unit
Collector to Base Voltage	V_{CB0}	-20	V
Collector to Emitter Voltage	V_{CEO}	-15	V
Emitter to Base Voltage	V_{EBO}	-3	V
Collector Current	I_C	-50	mA
Collector Dissipation	P_C	250	mW
Junction Temperature	T_j	150	$^\circ\text{C}$
Storage Temperature	T_{stg}	-55 to +150	$^\circ\text{C}$

Electrical Characteristics at $T_a = 25^\circ\text{C}$

			min	typ	max	unit
Collector Cutoff Current	I_{CBO}	$V_{CB} = -15\text{V}, I_E = 0$			-0.1	μA
Emitter Cutoff Current	I_{EBO}	$V_{EB} = -2\text{V}, I_C = 0$			-0.1	μA
DC Current Gain	h_{FE}	$V_{CE} = -10\text{V}, I_C = -5\text{mA}$	15			
Gain-Bandwidth Product	f_T	$V_{CE} = -10\text{V}, I_C = -5\text{mA}$	1.5	3.0		GHz
Output Capacitance	c_{ob}	$V_{CB} = -10\text{V}, f = 1\text{MHz}$		1.0	1.5	pF
Reverse Transfer Capacitance	c_{re}	$V_{CB} = -10\text{V}, f = 1\text{MHz}$		0.7		pF
Forward Transfer Gain	$ S_{21e} ^2$	$V_{CE} = -10\text{V}, I_C = -5\text{mA}, f = 0.9\text{GHz}$	5.0			dB
Maximum Available Power Gain	MAG	$V_{CE} = -10\text{V}, I_C = -5\text{mA}, f = 0.9\text{GHz}$		11		dB
Noise Figure	NF	$V_{CE} = -10\text{V}, I_C = -3\text{mA}, f = 0.9\text{GHz}$		2.0		dB

(Note) Marking: BS

Package Dimensions 2018A

(unit: mm)

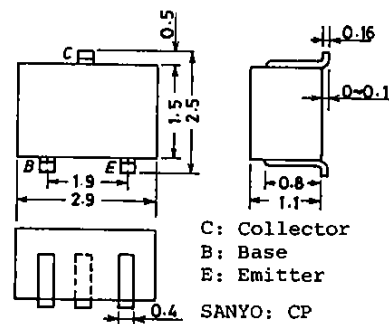
**SANYO Electric Co., Ltd. Semiconductor Business Headquarters**

TOKYO OFFICE Tokyo Bldg., 1-10, 1 Chome, Ueno, Taito-ku, TOKYO, 110 JAPAN

6069MO, TS No.2972-1/5

NF Test Circuit

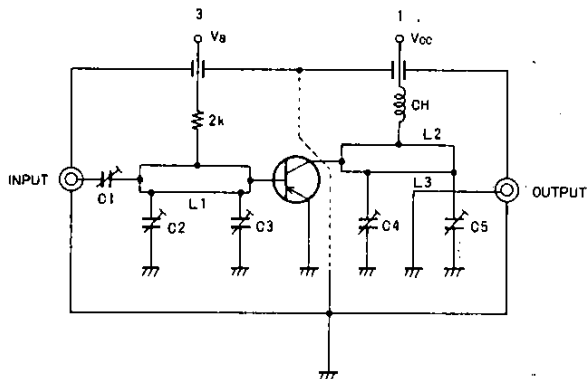

900MHz	
C1	~ 5 pF
C2	~ 10 pF
C3	~ 10 pF
C4	~ 10 pF
C5	~ 10 pF
L1	W≠1.5mm, 1≠25mm strip line
L2	W≠4mm, 1≠25mm strip line
L3	0.5φ, 1≠40mm
CH	2t+bead core

Unit (Resistance : Ω)

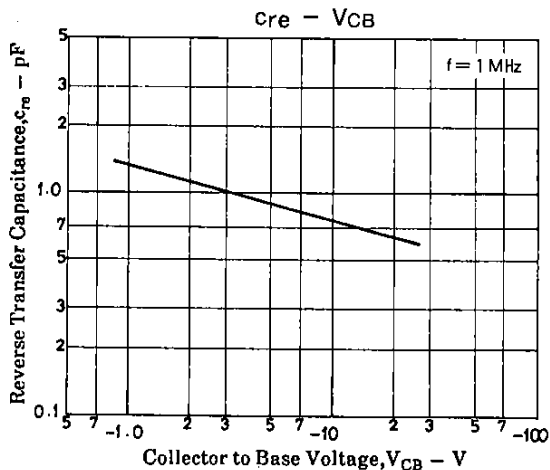
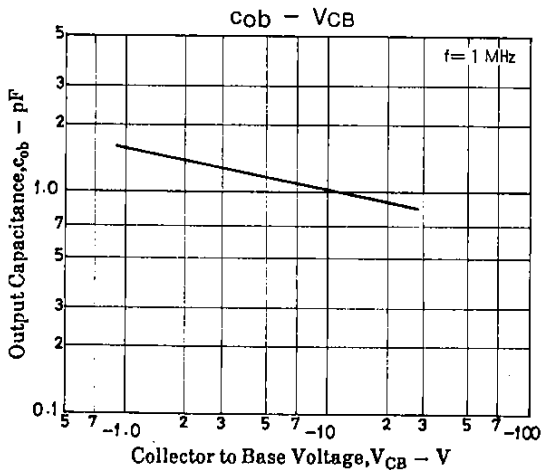
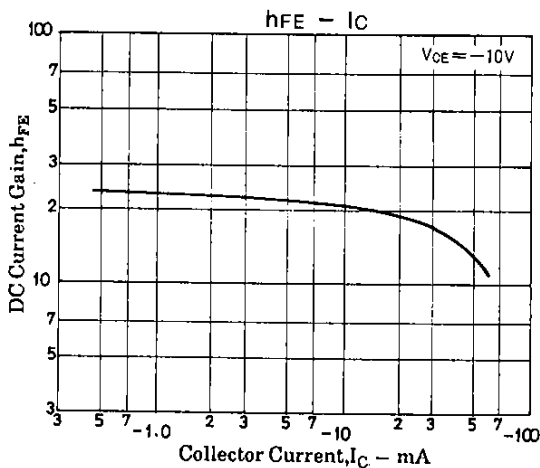
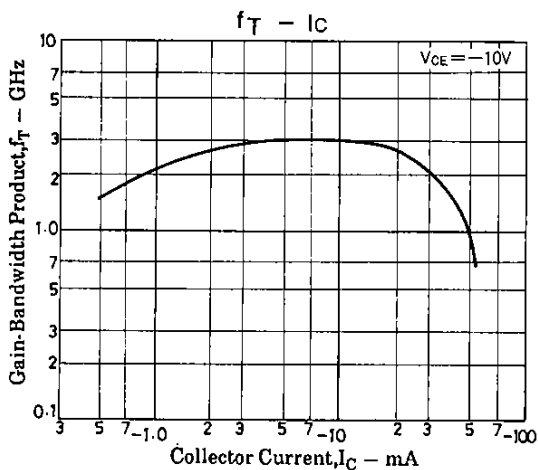

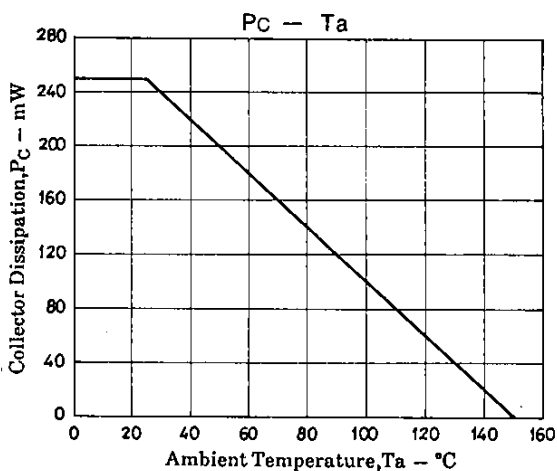
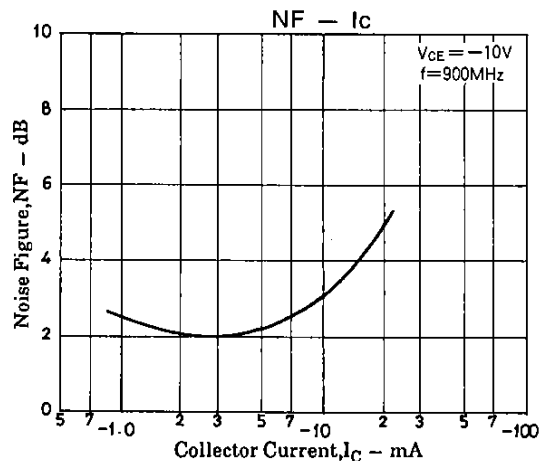
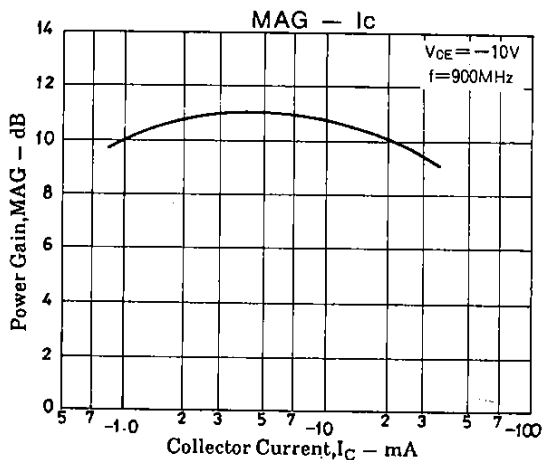

S_{11e} parameter

S_{11e} : $V_{CE} = -10V$

$f = 100MHz, 200 \sim 1200MHz (200MHz \text{ step})$

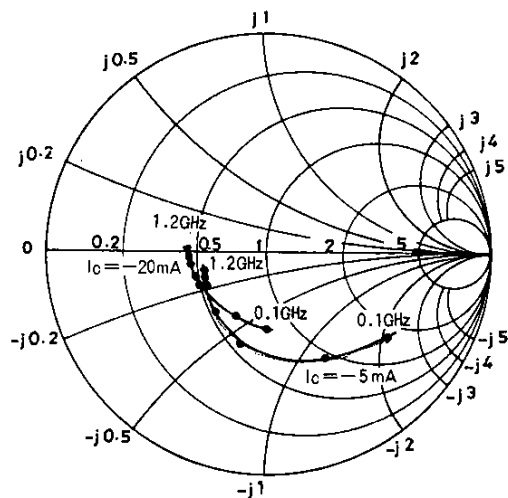

S_{12e} : $V_{CE} = -10V$

$f = 100MHz, 200 \sim 1200MHz (200MHz \text{ step})$

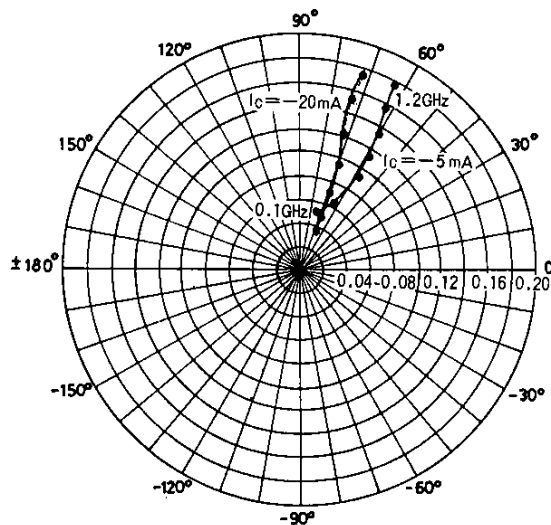

2SA1669

S21e : $V_{CE} = -10V$

$f = 100MHz, 200 \sim 1200MHz (200MHz \text{ step})$

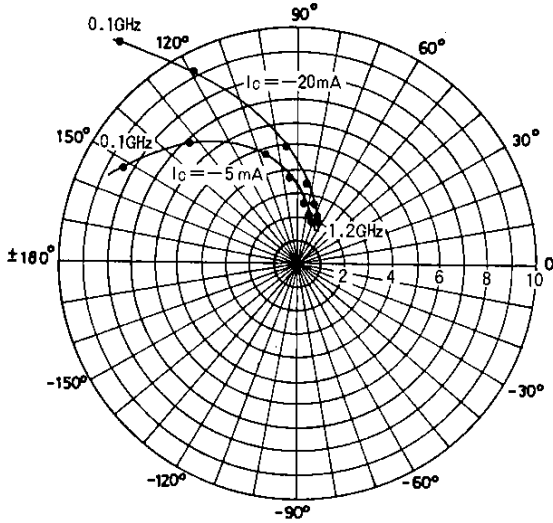

S22e : $V_{CE} = -10V$

$f = 100MHz, 200 \sim 1200MHz (200MHz \text{ step})$

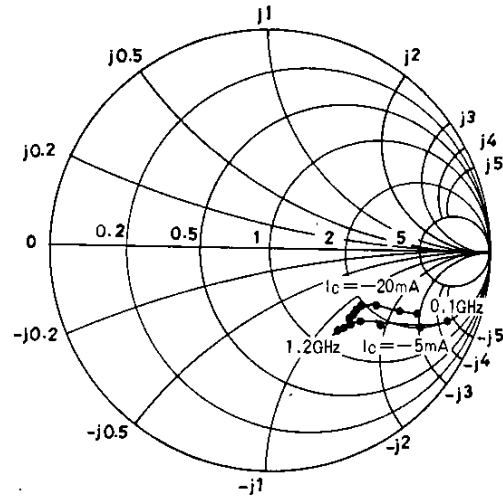

S parameter (Common emitter)

$V_{CE} = -10V, I_C = -5 \text{ mA}, Z_0 = 50\Omega$

Freq (MHz)	S ₁₁	∠S ₁₁	S ₂₁	∠S ₂₁	S ₁₂	∠S ₁₂	S ₂₂	∠S ₂₂
100	0.707	-33.1	8.215	151.1	0.043	68.6	0.856	-19.8
200	0.589	-60.3	6.763	132.2	0.059	62.0	0.761	-25.4
400	0.435	-104.7	4.810	106.5	0.089	56.4	0.584	-34.2
600	0.373	-128.1	3.503	93.2	0.110	57.3	0.508	-36.6
800	0.349	-144.4	2.728	83.4	0.130	59.5	0.474	-39.0
900	0.346	-150.1	2.492	80.0	0.142	60.9	0.464	-40.3
1000	0.344	-155.4	2.266	76.8	0.154	61.4	0.459	-41.7
1200	0.340	-163.6	1.971	70.6	0.176	62.1	0.452	-45.2

$V_{CE} = -10V, I_C = -20mA, Z_0 = 50\Omega$

Freq (MHz)	S ₁₁	∠S ₁₁	S ₂₁	∠S ₂₁	S ₁₂	∠S ₁₂	S ₂₂	∠S ₂₂
100	0.348	-92.8	12.039	129.4	0.031	67.3	0.727	-22.9
200	0.330	-116.7	9.073	118.2	0.041	66.0	0.634	-24.8
400	0.350	-151.2	4.962	95.1	0.068	67.7	0.510	-26.5
600	0.353	-164.5	3.408	84.4	0.093	69.9	0.481	-28.1
800	0.360	-172.9	2.591	76.4	0.118	71.6	0.470	-31.1
900	0.366	-176.2	2.346	73.3	0.131	72.0	0.467	-32.9
1000	0.371	-178.4	2.142	70.8	0.146	71.8	0.467	-34.8
1200	0.379	-176.2	1.851	65.2	0.171	71.1	0.466	-39.1

- No products described or contained herein are intended for use in surgical implants, life-support systems, aerospace equipment, nuclear power control systems, vehicles, disaster/crime-prevention equipment and the like, the failure of which may directly or indirectly cause injury, death or property loss.
- Anyone purchasing any products described or contained herein for an above-mentioned use shall:
 - ① Accept full responsibility and indemnify and defend SANYO ELECTRIC CO., LTD., its affiliates, subsidiaries and distributors and all their officers and employees, jointly and severally, against any and all claims and litigation and all damages, cost and expenses associated with such use:
 - ② Not impose any responsibility for any fault or negligence which may be cited in any such claim or litigation on SANYO ELECTRIC CO., LTD., its affiliates, subsidiaries and distributors or any of their officers and employees jointly or severally.
- Information (including circuit diagrams and circuit parameters) herein is for example only; it is not guaranteed for volume production. SANYO believes information herein is accurate and reliable, but no guarantees are made or implied regarding its use or any infringements of intellectual property rights or other rights of third parties.