



## TO-92S Plastic-Encapsulated Transistors

### 2SA1585S TRANSISTOR (PNP)

#### FEATURES

Power dissipation

$$P_D : 0.4W (T_{amb}=25^{\circ}C)$$

Collector current

$$I_{CM} : -2A$$

Collector-base voltage

$$V_{(BR)CBO} : -20V$$

Operating and storage junction temperature range

$$T_J, T_{stg} : -55^{\circ}C \text{ to } +150^{\circ}C$$

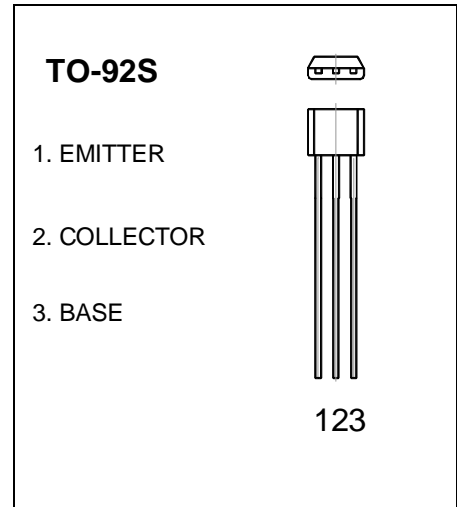

#### ELECTRICAL CHARACTERISTICS ( $T_{amb}=25^{\circ}C$ unless otherwise specified)

Parameter	Symbol	Test conditions	MIN	TYP	MAX	UNIT
Collector-base breakdown voltage	$V_{(BR)CBO}$	$I_C = -50\mu A, I_E = 0$	-20			V
Collector-emitter breakdown voltage	$V_{(BR)CEO}$	$I_C = -1 \text{ mA}, I_B = 0$	-20			V
Emitter-base breakdown voltage	$V_{(BR)EBO}$	$I_E = -50\mu A, I_C = 0$	-6			V
Collector cut-off current	$I_{CBO}$	$V_{CB} = -20V, I_E = 0$			-0.1	$\mu A$
Emitter cut-off current	$I_{EBO}$	$V_{EB} = -5V, I_C = 0$			-0.1	$\mu A$
DC current gain	$h_{FE}$	$V_{CE} = -2V, I_C = -0.1A$	120		390	
Collector-emitter saturation voltage	$V_{CEsat}$	$I_C = -2A, I_B = -0.1A$			-0.5	V
Transition frequency	$f_T$	$V_{CE} = -2V, I_C = -0.5A$ $F = 100MHz$	200			MHz

#### CLASSIFICATION OF $h_{FE}$

Rank	Q	R
Range	120-170	180-390