

Silicon PNP Power Transistors

2SA1389

DESCRIPTION

- With MT-200 package
- Fast switching speed
- Excellent safe operating area

APPLICATIONS

- High frequency power amplifiers
- Audio power amplifiers
- Switching regulators
- DC-DC converters

PINNING(see Fig.2)

PIN	DESCRIPTION
1	Base
2	Collector;connected to mounting base
3	Emitter

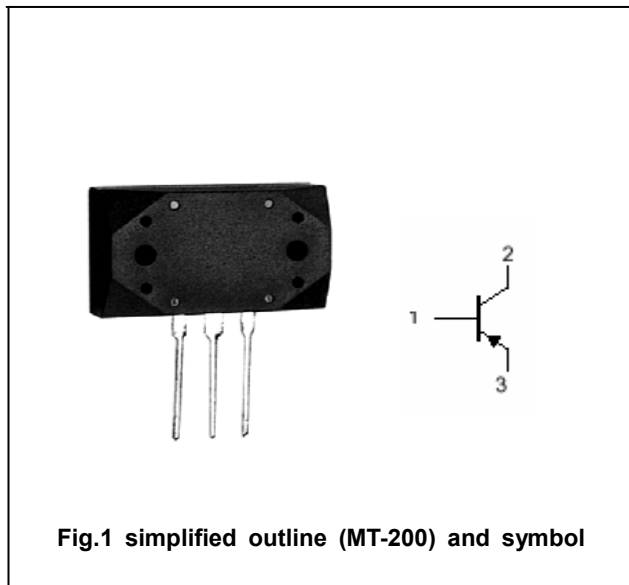

Absolute maximum ratings(Ta=25°C)

SYMBOL	PARAMETER	CONDITIONS	VALUE	UNIT
V _{CBO}	Collector-base voltage	Open emitter	-160	V
V _{CEO}	Collector-emitter voltage	Open base	-160	V
V _{EBO}	Emitter-base voltage	Open collector	-7	V
I _C	Collector current		-12	A
P _C	Collector power dissipation	T _C =25°C	120	W
T _j	Junction temperature		150	°C
T _{stg}	Storage temperature		-55~150	°C

Silicon PNP Power Transistors

2SA1389

CHARACTERISTICS

T_j=25 °C unless otherwise specified

SYMBOL	PARAMETER	CONDITIONS	MIN	TYP.	MAX	UNIT
V _{(BR)CEO}	Collector-emitter breakdown voltage	I _C =-1mA ; I _B =0	-160			V
V _{(BR)EBO}	Emitter-base breakdown voltage	I _E =-50μA; I _C =0	-7			V
V _{CEsat}	Collector-emitter saturation voltage	I _C =-5A; I _B =-0.5A			-1.8	V
V _{BE}	Base-emitter voltage	I _C =-5A; V _{CE} =-5V			-1.7	V
I _{CBO}	Collector cut-off current	V _{CB} =-160V; I _E =0			-50	μA
I _{CEO}	Collector cut-off current	V _{CE} =-160V; I _B =0			-1	mA
I _{EBO}	Emitter cut-off current	V _{EB} =-7V; I _C =0			-50	μA
h _{FE-1}	DC current gain	I _C =-1A ; V _{CE} =-5V	60		200	
h _{FE-2}	DC current gain	I _C =-7A ; V _{CE} =-5V	40			
f _T	Transition frequency	I _C =-1A ; V _{CE} =-10V		30		MHz

Silicon PNP Power Transistors

2SA1389

PACKAGE OUTLINE

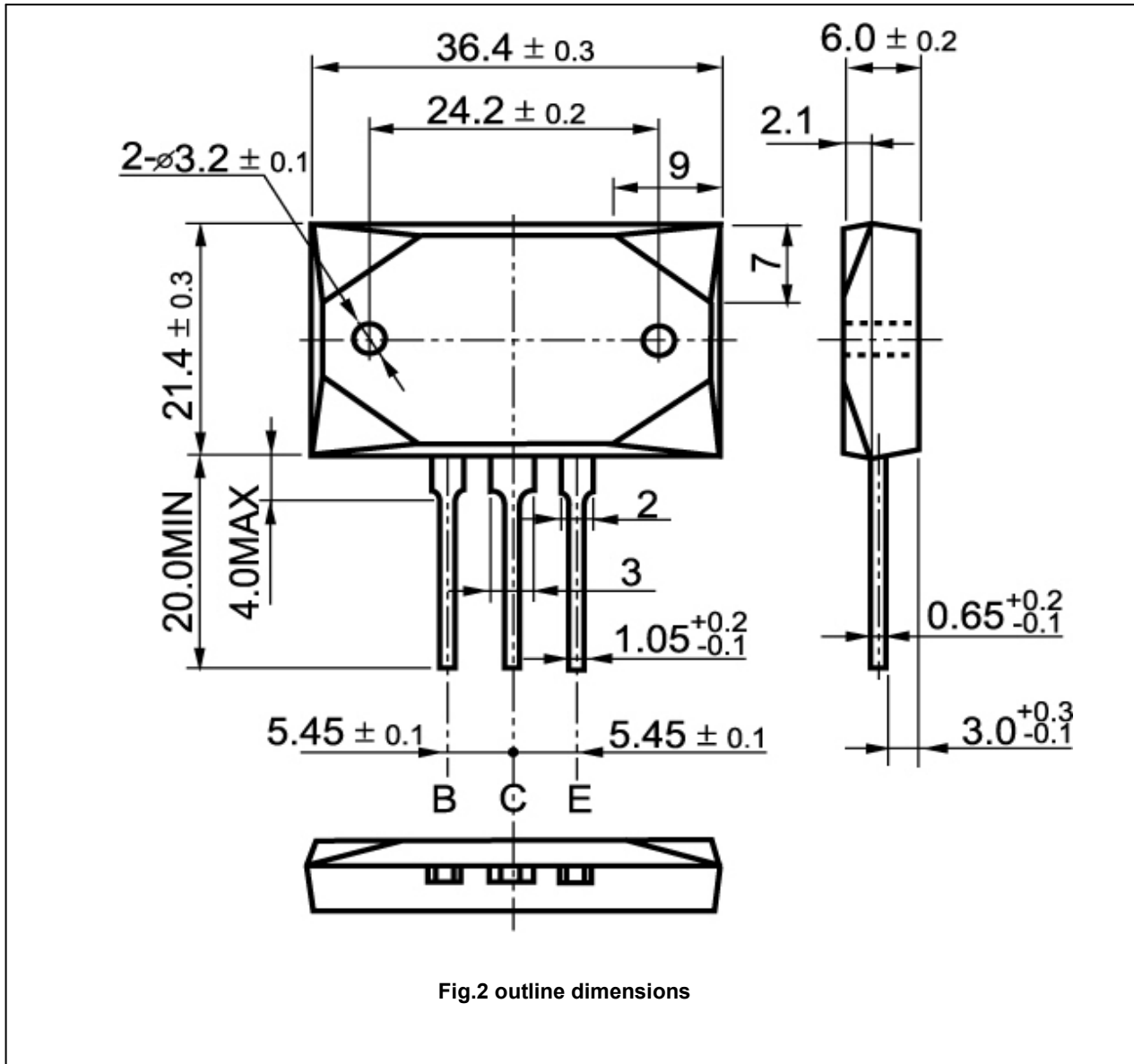

Fig.2 outline dimensions