

Features

- Eight fully independent, T1/E1/J1 framers
- 3.3V supply with 5V tolerant inputs
- Selectable 2.048 Mbit/s or 8.192 Mbit/s serial buses for both data and signaling
- Framing Modes:
 - T1: D4, ESF, T1DM
 - E1: Basic Framing, CRC4 multiframing and Signaling Multiframing
- Supports Inverse Mux for ATM
- Timeslot assignable HDLC
- IEEE-1149.1 (JTAG) test port

Applications

- T1/E1/J1 add/drop multiplexers
- V5.1 and V5.2 access network interfaces
- CO and PBX equipment interfaces
- Primary rate ISDN nodes
- Digital Cross-connect Systems (DCS)
- Wireless base stations

DS5063

ISSUE 2

October 2001

Ordering Information	
MT9072AB	208 Pin LQFP
MT9072AV	256 Pin LPGA
-40 to +85 °C	

Description

The MT9072 is a multi-port T1/E1/J1 framing device that integrates eight fully independent, feature rich framers. The device is software selectable between T1, E1 or J1 modes and meets the latest relevant recommendations and standards from Telcordia, ANSI, ETSI and ITU-T. An extensive suite of features make the MT9072 very flexible and suitable for a wide variety of applications around the globe.

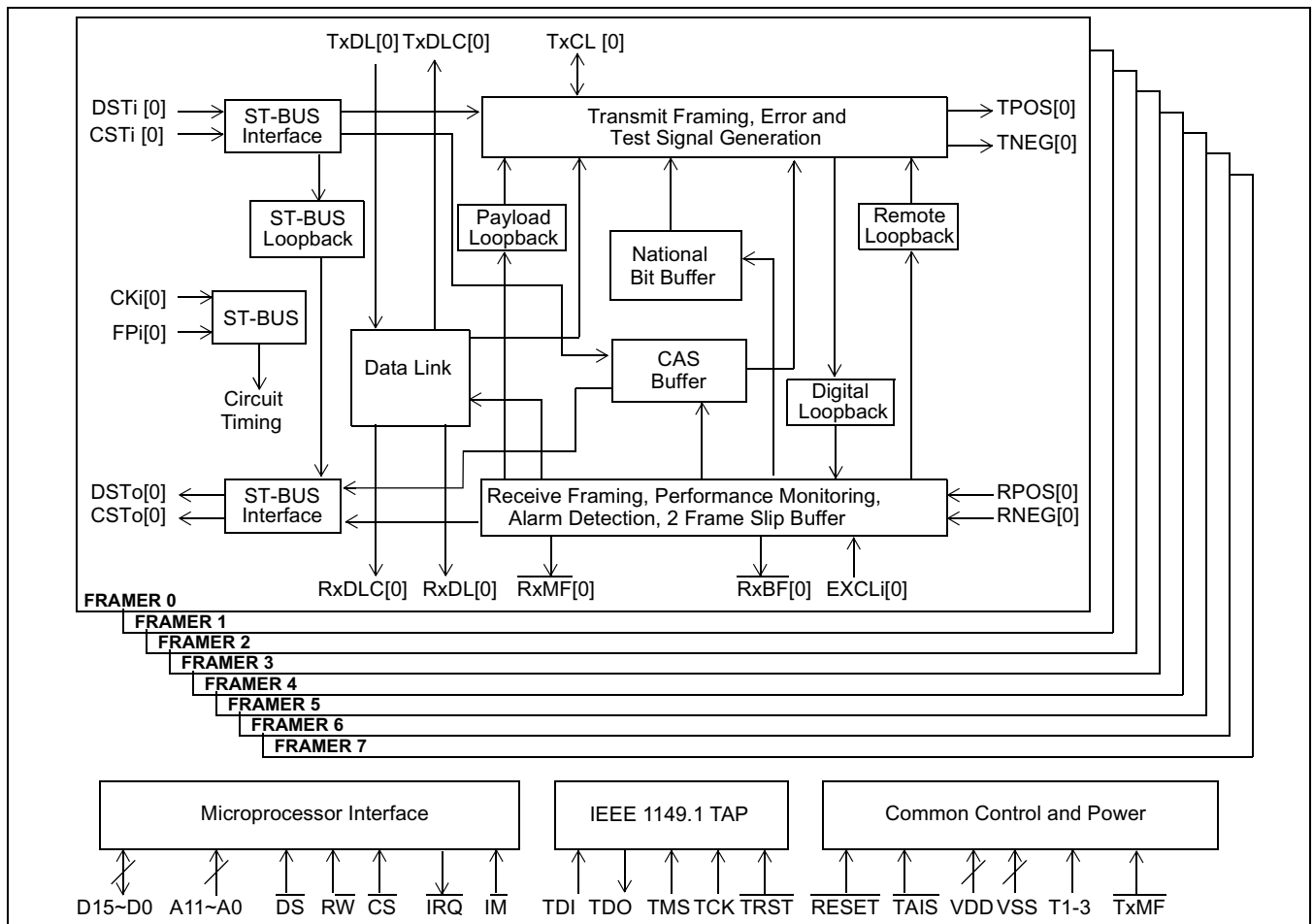

Figure 1 - Functional Block Diagram

MT9072 Detailed Feature Summary

Standards Compliance and Support

T1/J1 Mode

ANSI:

T1.102, T1.231
T1.403, T1.408

AT&T:

TR 62411, PUB43801

Telcordia:

GR-303-CORE

ITU-T:

G.802

TTC:

JT-G703, JT-G704
JT-G706

E1 Mode

ETSI:

TBR4, TBR13
ETS 300 233, ETS 300 347 (V5.2)

ITU-T:

G.703, G.704, G.706, G.711, G.732
G.775, G.796, G.823, I.431
G.965 (V5.2)

Access and Control

- A 16-bit parallel Motorola or Intel non-multiplexed microprocessor interface is used to access the control and status registers.

Backplane Interfaces

- 2.048Mbit/s or 8.192Mbit/s ST-BUS
- 2.048Mbit/s GCI bus
- IMA (Inverse Mux for ATM) mode, 1.544Mbit/s (T1) or 2.048Mbit/s (E1) serial bus with asynchronous transmit and receive timing for Inverse MUX for ATM applications.
- CSTo/CSTi pins can be used to access the receive/transmit signaling data
- RxDL pin can be used to access the entire B8ZS/HDB3 decoded receive stream including framing bits
- TxDL pin can be used to transmit data on the FDL (T1) or the Sa bits (E1)

T1/J1 Mode

- PCM24 channels 1-24 are mapped to ST-BUS channels 0-23 respectively
- The framing-bit is mapped to ST-BUS channel 31

E1 Mode

- PCM30 timeslots 0-31 are mapped to ST-BUS channels 0-31 respectively

Data LinkT1/J1 Mode

- Three methods are provided to access the datalink:
 1. TxDL and RxDL pins support transmit and receive datalinks
 2. Bit Oriented Messages are supported via internal registers
 3. An internal HDLC can be assigned to transmit/receive over the FDL in ESF mode

E1 Mode

- Two methods are provided to access the datalink:
 1. TxDL and RxDL pins support transmit and receive datalinks over the Sa4~Sa8 bits
 2. An internal HDLC can be assigned to transmit/receive data via the Sa4~Sa8 bits
- In transparent mode, if the Sa4 bit is used for an intermediate datalink, the CRC-4 remainder can be updated to reflect changes to the Sa4 bit

One Embedded Floating HDLC per Framer

- Flag generation and Frame Check Sequence (FCS) generation and detection, zero insertion and deletion
- Continuous flags, or continuous 1s are transmitted between frames
- Transmit frame-abort
- Invalid frame handling:
 - Frames yielding an incorrect FCS are tagged as bad packets
 - Frames with fewer than 25 bits are ignored
 - Frames with fewer than 32 bits between flags are tagged as bad packets
 - Frames interrupted by a Frame-Abort sequence remain in the FIFO and an interrupt is generated
- Access is provided to the receive FCS
- FCS generation can be inhibited for terminal adaptation
- Recognizes single byte, dual byte and all call addresses
- Independent, 32 byte deep transmit and receive FIFOs
- Receive FIFO maskable interrupts for nearly full and overflow conditions
- Transmit FIFO maskable interrupts for nearly empty and underflow conditions
- Maskable interrupts for transmit end-of-packet and receive end-of-packet
- Maskable interrupts for receive bad-frame (includes frame abort)
- Transmit-to-receive and receive-to-transmit loopbacks are provided
- Transmit and receive bit rates and enables are independent
- Frame aborts can be sent under software control and they are automatically transmitted in the event of a transmit FIFO underrun

T1/J1 Mode

- Assignable to the ESF Facility Data Link or any other channel
- Operates at 4 kbit/s (FDL), 56 kbit/s or 64 kbit/s

E1 Mode

- Assignable to timeslot-0, bits Sa4~Sa8 or any other timeslot
- Operates at 4, 8, 12, 16 or 20 kbit/s (Sa bits) or 64 kbit/s

Common Channel Signaling Timeslot Assigner

- Selected 64 Kbit/s CCS channels (for V5.2 and GR-303) can be routed to/from an external multichannel HDLC, using the CSTi/0 pins

Access and Monitoring for National (Sa) Bits (E1 mode only)

In addition to the datalink functions, the Sa bits can be accessed using:

- Single byte register
- Five byte transmit and receive national bit buffers
- A maskable interrupt is generated on the change of state of any Sa bit

Slip Buffers

T1/J1 Mode

E1 Mode

Transmit Slip Buffer

- Two-frame slip buffer capable of performing a controlled slip. Intended for rate conversion in the transmit direction
- Programmable delay
- Transmit slips are independent of receive slips
- Indication of slip
- Indication of slip direction

Receive Slip Buffer

- Two-frame slip buffer capable of performing a controlled slip
- Wander tolerance of 142 UI (92 μ s) peak
- Indication of slip
- Indication of slip direction

Receive Slip Buffer

- Two-frame slip buffer capable of performing a controlled slip
- Wander tolerance of 208 UI peak-to-peak
- Indication of slip
- Indication of slip direction

Interface to the Physical Layer Device

- Single rail NRZ
- Dual rail (AMI) RZ or NRZ
- Transmits/samples data on the rising or falling edge of the line clock

T1/J1 Mode

E1 Mode

- Optional B8ZS line coding
- Pulse density enforcement
- Forced ones stuffing (bit 7 of a DS0)
- GTE zero suppression code
- Bell zero suppression code
- DDS zero suppression code
- Optional HDB3 line coding

Framing AlgorithmT1/J1 Mode

- Synchronizes with D4 or ESF protocols
- Supports T1DM synchronization with the D4 pattern and timeslot 24 T1DM Synchronization bytes
- Framing circuit is off-line
- Transparent transmit and receive mode
- In D4 mode Fs bits can be optionally cross checked with the Ft bits
- The start of the ESF multiframe can be determined by the following methods:
 - Free-run
 - Software reset
 - Synchronized to the incoming multiframe
- An automatic reframe is initiated if the framing bit error density exceeds the programmed threshold
- In transparent mode no reframing is forced by the device
- Software can force a reframe at any time
- In ESF mode the CRC-6 bits can be optionally confirmed before forcing a new frame alignment
- During a reframe the signaling bits are frozen, and error counting for Ft, Fs, ESF framing pattern and CRC-6 bits is suspended
- If J1 CRC-6 is selected the Fs bits are included in the CRC-6 calculation
- J1-CRC-6 and J1-Yellow Alarm can be independently selected
- Supports Robbed Bit Signaling
- Optional forced ones insertion

E1 Mode

- Three distinct and independent E1 framing algorithms
 1. Basic frame alignment
 2. Signaling multiframe alignment
 3. CRC-4 multiframe alignment
- Transparent receive mode
- Transparent transmit mode
- Optional automatic interworking between interfaces with and without CRC-4 processing capabilities is supported
- An automatic reframe is forced if 3 consecutive frame alignment patterns or three consecutive non-frame alignment bits are received in error
- In receive transparent mode no reframing is forced by the device
- Software can force a reframe at any time
- Software can force a multiframe reframe at any time
- E-bits can optionally be set to zero or one until CRC synchronization is achieved
- Optional automatic RAI
- Supports CAS multiframing
- Optional automatic Y-bit to indicate CAS multiframe alignment

Channel Associated Signaling

- ABCD or AB bits can be automatically inserted and extracted
- Transmit ABCD or AB bits can be passed via the microport or via the CSTi pin
- Receive ABCD or AB bits are accessible via the microport or via the CSTo pin
- Unused nibble positions in the CSTi/CSTo bandwidth are tri-stated
- An interrupt is provided in the event of changes in any of the signaling bits
- Receive signaling bits are frozen if digital loss of signal or loss of multiframe alignment is declared

T1/J1 Mode

- Signaling bits can be debounced by 6 ms
- Robbed bit or clear channel signaling are selected on a channel by channel basis
- Signaling interrupts period can be selected: 1, 4 or 8 msec

E1 Mode

- Signaling bits can be debounced by 14 ms
- Signaling interrupt period can be selected 1, 4 or 8 msec

AlarmsT1/J1 ModeE1 Mode*Yellow Alarm*

D4 mode, two types:

1. Bit position 2 is zero for virtually every DS0 over 48ms
2. Two consecutive ones in the S-bit position of the twelfth frame

ESF mode, two types:

3. Reception of 0000000011111111 in eight or more codewords out of ten (T1)
4. Reception of 1111111111111111 in eight or more codewords out of ten (J1)

T1DM mode :

Bit 2 of the T1DM synchronization byte is 0

Alarm Indication Signal (AIS)

- Declared if fewer than six zeros are detected during a 3 ms interval

Loss Of Signal (LOS)

- Loss Of Signal is declared if 192 or 32 consecutive zeros are received

Remote Alarm Indication (RAI)

- Bit 3 of the receive NFAS

Alarm Indication Signal (AIS)

- Unframed all ones signal for at least a double frame or two double frames

Timeslot 16 Alarm Indication Signal

- All ones signal in timeslot 16

Loss Of Signal (LOS)

- Loss Of Signal is declared if 192 or 32 consecutive zeros are received

Remote Signaling Multiframe Alarm

- Y-bit of the multiframe alignment signal

Maskable InterruptsT1/J1 Mode Interrupts

- Framing bit error counter overflow
- CRC-6 error counter overflow
- Out of frame alignment counter overflow
- Change of frame alignment counter overflow
- Bipolar violation counter overflow
- PRBS error counter overflow
- PRBS multiframe counter overflow
- Multiframes out of alignment counter overflow
- Change of state of terminal frame synchronization
- Change of state of multiframe synchronization
- Receive framing bit error
- Change of receive frame alignment after a reframe
- Reception of a severely errored frame
- Reception of AIS
- Receive CRC-6 error
- Reception of digital LOS
- D4 yellow alarm detected
- D4 yellow alarm detected for 48ms
- Secondary D4 yellow alarm received
- ESF yellow alarm received
- T1DM yellow alarm received
- Receive bipolar violation
- Receive PRBS error
- Pulse density violation
- Loop code enable detected
- Loop code disable detected
- Receive new bit oriented message (debounced)
- Bit oriented message match detected
- Signaling (AB or ABCD) bit change

E1 Mode Interrupts

- Receive FEBE and RAI
- Receive slip
- Receive Y-bit
- Receive V3 auxiliary pattern (0101010...)
- Receive change of state of RAI
- Receive change of state of AIS
- Receive change of state of AIS in timeslot 16
- Change of state of reception of digital LOS
- Remote CRC-4 and RAI for 10ms
- Remote CRC-4 and RAI for 450ms
- Reception of consecutive errored FASs
- Remote CRC-4 multiframe generator/detector failure
- Change of state of CRC-4 multiframe synchronization
- Change of state of signaling multiframe synchronization
- Change of state of basic frame alignment
- Loss of frame sync counter overflow
- FAS error counter overflow
- FAS error indication
- FAS bit error counter overflow
- FAS bit error indication
- CRC-4 error counter overflow
- Receive CRC-4 error
- Receive bipolar violation error counter overflow
- Receive bipolar violation
- Receive E-bit counter overflow
- Receive E-bit error
- PRBS multiframe counter overflow
- PRBS error counter overflow

HDLC Interrupts

- Go ahead pattern received
- End of packet received
- End of packet transmitted
- End of packet read from receive FIFO
- Transmit FIFO low (16 bytes)
- Frame abort received
- Transmit FIFO underrun
- Receive FIFO full (above 16 byte threshold)
- Receive FIFO overflow

Maskable Interrupts (continued)T1/J1 Mode Interrupts

- One second timer
- Two second timer
- Excessive zero counter overflow
- Excessive zero event
- Transmit slip
- Receive slip

E1 Mode Interrupts

- Receive PRBS error
- Sa5 bit set
- Sa6 bit set
- Eighth consecutive identical Sa6 nibble
- Sa6 nibble change
- Sa nibble change
- Sa5 bit change
- Sa bit change
- Signaling (CAS) bit change
- Two millisecond timer
- Ten millisecond timer
- One hundred millisecond timer
- One second timer

Performance MonitoringError Counters

- All counters can be cleared or preset by writing to the appropriate locations
- Maskable occurrence interrupt
- Maskable overflow interrupt
- Counters can be latched on one second intervals

T1/J1 Mode

- CRC-6 Multiframe Counter (8-bit)
- PRBS Error Counter (8-bit)
- Multiframe Out of Sync Counter (16-bit)
- Framing Bit Error Counter (16-bit)
- Bipolar Violation Counter (16-bit)
- CRC-6 Error Counter (16-bit)
- Out of Frame Alignment Counter (8-bit)
- Change of Frame Alignment Counter (8-bit)
- Excessive Zeros Counter (8-bit)

E1 Mode

- CRC-4 Multiframe Counter (8-bit)
- PRBS Error Counter (8-bit)
- Loss of Basic Frame Sync (16-bit)
- E-bit Error Counter (16-bit)
- Bipolar Violation Counter (16-bit)
- CRC-4 Error Counter (16-bit)
- FAS Bit Error Counter (8-bit)
- FAS Error Counter (8-bit)

Error InsertionT1/J1 Mode

- Bipolar Violations
- CRC-6 errors
- Ft errors
- Fs errors
- Payload errors
- Loss of Signal error

E1 Mode

- E-bit
- Bipolar Violations
- CRC-4 Errors
- FAS Errors
- NFAS Errors
- Payload Errors
- Loss of Signal Error

Loopbacks

- Digital loopback
- Remote loopback
- ST-BUS loopback
- Payload loopback
- Local timeslot loopback
- Remote timeslot loopback
- Framer to framer loopback

Per Timeslot Control

The following features can be controlled on a per timeslot basis:

- Clear Channel Capability (only used in T1/J1)
- Choice of sourcing transmit signaling bits from microport or CSTi pin
- Remote timeslot loopback
- Local timeslot loopback
- PRBS insertion and reception
- Digital milliwatt pattern insertion
- Per channel inversion for transmit and receive
- Transmit and receive idle code

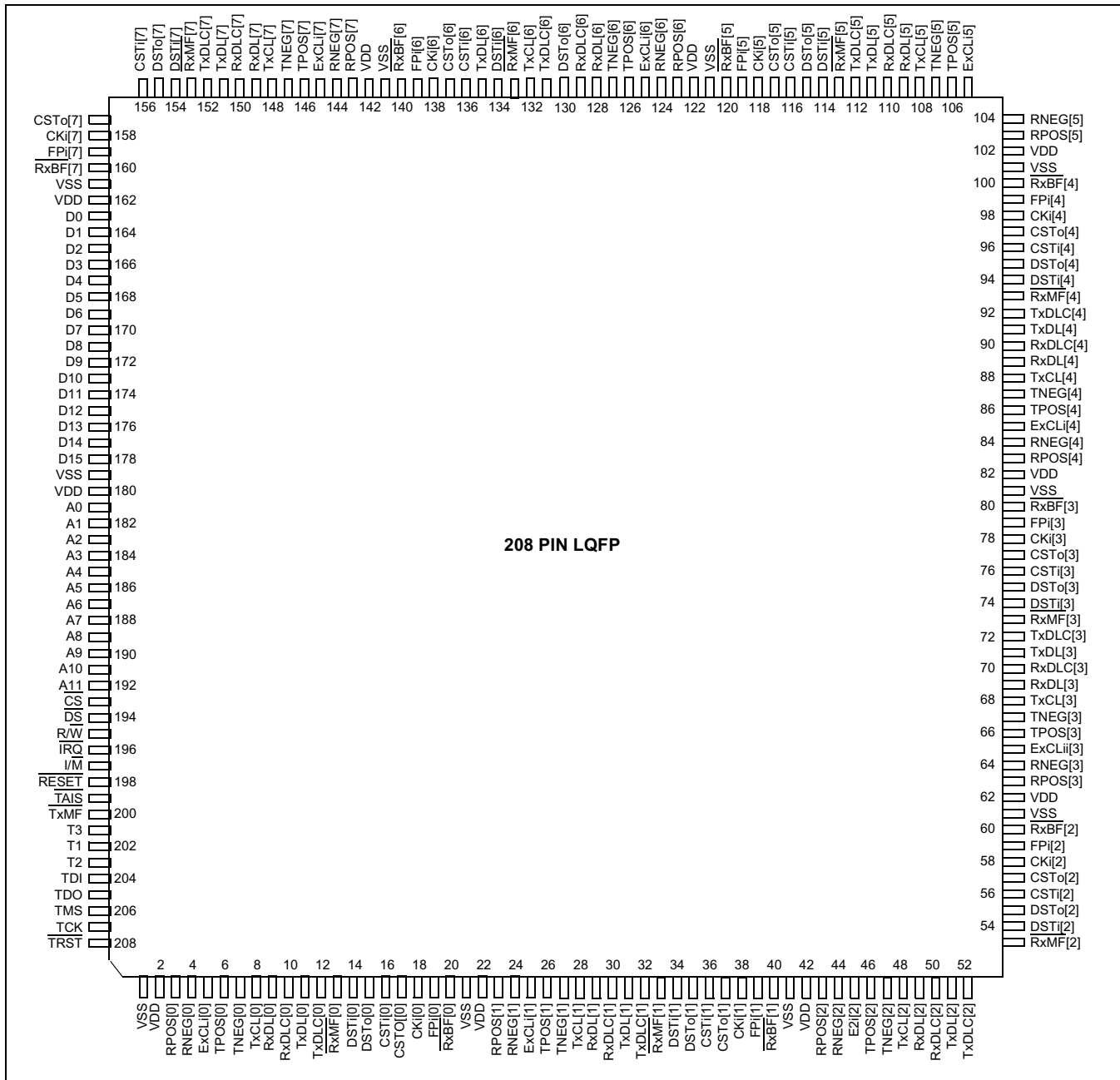

Figure 2 - Pin Connections (Jedec MS-026)

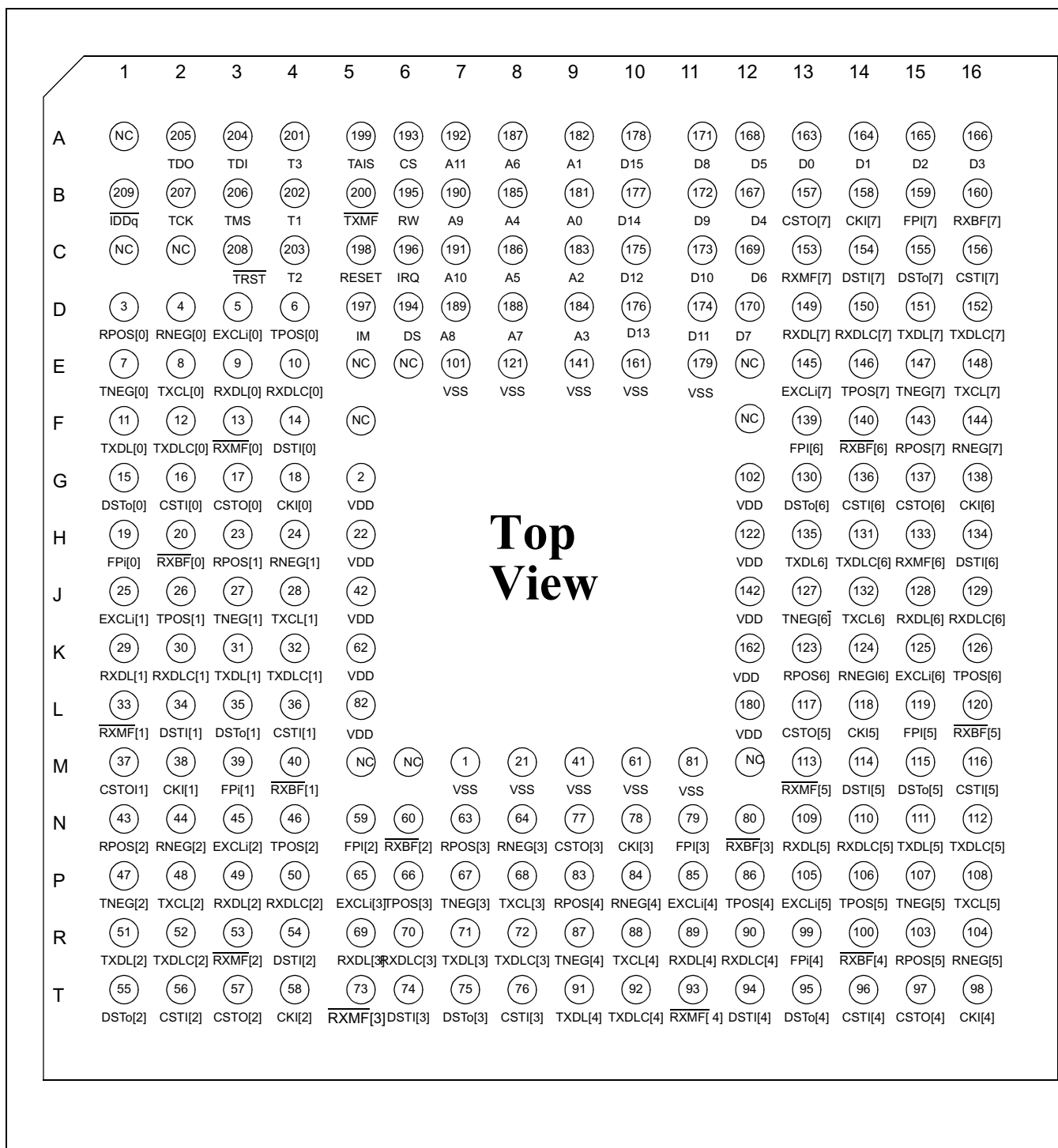

Figure 3 - 256 PIN LPGA (Jedec MO-192)

Note: The pin numbers inside the balls for the LPGA package correspond to the pin numbers on the device in the Pin Description Table.

Pin Description

Pin #		Name	Type	Description (see Notes 1 to 7)
LQFP	LBGA			
1,21,41,61, 81,101,121, 141,161, 179	E7,E8,E9, E10,E11, M7,M8,M9, M10,M11	V _{SS}	P	Ground. 0V _{DC} .
2,22,42,62, 82,102,122, 142,162,18 0	G5,H5,J5, K5,L5,G12, H12J12,K1 2,L12	V _{DD}	P	Supply Voltage. +3.3V _{DC} nominal.
3 23 43 63 83 103 123 143	D1 H3 N1 N7 P9 R15 K13 F15	RPOS[0] RPOS[1] RPOS[2] RPOS[3] RPOS[4] RPOS[5] RPOS[6] RPOS[7]	I	<p>Receive Positive. This pin is an input for the receive side of the framer; it typically interfaces to an LIU. If used by itself it can accept single rail NRZ (Non Return to Zero) data. If RPOS is used in conjunction with RNEG it can accept dual rail NRZ data or dual rail RZ (Return to Zero) data. The clock at the EXCLi pin is used to clock data into the RPOS pin. Pins RPOS[0-7] are used for Framers[0-7] respectively.</p> <p>In T1 mode, transmit line codes are selected with control bits: RZCS1-0, RXB8ZS, RZNRZ and UNIBI (Address Y01). T1 mode is selected if the T1E0 bit (Address 900) is 1.</p> <p>In E1 mode, line codes are selected with control bits: COD0-1 and RHDB3 at (Address Y02). E1 mode is selected if the T1E0 bit (Address 900) is 0.</p>
4 24 44 64 84 104 124 144	D2 H4 N2 N8 P10 R16 K14 F16	RNEG[0] RNEG[1] RNEG[2] RNEG[3] RNEG[4] RNEG[5] RNEG[6] RNEG[7]	I	<p>Receive Negative. This pin is an input for the receive side of the framer; it typically interfaces to an LIU. RNEG is used in conjunction with RPOS to accept dual rail NRZ (Non Return to Zero) data or dual rail RZ (Return to Zero) data. The clock at the EXCLi pin is used to clock data into the RNEG pin. Pins RNEG[0-7] are used for Framers[0-7] respectively.</p> <p>In T1 mode, receive line codes are selected with control bits: RZCS1-0, RXB8ZS, RZNRZ and UNIBI at (Address Y01). T1 mode is selected if the T1E0 bit (Address 900) is 1.</p> <p>In E1 mode, line codes are selected with control bits: COD0-1 and RHDB3 at (Address Y02). E1 mode is selected if the T1E0 bit (Address 900) is 0.</p>
5 25 45 65 85 105 125 145	D3 J1 N3 P5 P11 P13 K15 E13	EXCLi(0) EXCLi(1) EXCLi(2) EXCLi(3) EXCLi(4) EXCLi(5) EXCLi(6) EXCLi(7)	I	<p>1.544/2.048 MHz Extracted Clock. The rising edge of the clock applied at this input is used to clock RZ data into the receive side of the framer on pins RPOS and RNEG. If RPOS/RNEG are configured for NRZ input then either a rising or falling edge on the EXCLi clock can be selected to clock RPOS/RNEG data. Pins EXCLi[0-7] are used for Framers[0-7] respectively.</p> <p>In T1 mode, this pin accepts a 1.544MHz extracted clock. An active rising or falling edge is selected with the CLKE bit (Address Y01). See Figure 47.</p> <p>In E1 mode, this pin accepts a 2.048MHz extracted clock. An active rising or falling edge is selected with the CLKE bit (Address Y02). See Figure 66.</p>

Pin Description (continued)

Pin #		Name	Type	Description (see Notes 1 to 7)
LQFP	LBGA			
6 26 46 66 86 106 126 146	D4 J2 N4 P6 P12 P14 K16 E14	TPOS[0] TPOS[1] TPOS[2] TPOS[3] TPOS[4] TPOS[5] TPOS[6] TPOS[7]	O	<p>Transmit Positive. This pin is an output for the transmit side of the framer; it typically interfaces to an LIU. If used by itself it can provide single rail NRZ (Non Return to Zero) data. If TPOS is used in conjunction with TNEG it can provide dual rail NRZ data or dual rail RZ (Return to Zero) data. The clock at the TXCL pin is used to clock data out of the TPOS pin. Pins TPOS[0-7] are used for Framers[0-7] respectively.</p> <p>In T1 mode, line codes are selected with control bits: TZCS2-0, TPDV, TXB8ZS, RZNRZ and UNIBI (Address Y01). T1 mode is selected if the T1E0 bit (Address 900) is 1.</p> <p>In E1 mode, line codes are selected with control bits: COD0-1 and THDB3 (Address Y02). E1 mode is selected if the T1E0 bit (Address 900) is 0.</p>
7 27 47 67 87 107 127 147	E1 J3 P1 P7 R9 P15 J13 E15	TNEG[0] TNEG[1] TNEG[2] TNEG[3] TNEG[4] TNEG[5] TNEG[6] TNEG[7]	O	<p>Transmit Negative. This pin is an output for the transmit side of the framer; it typically interfaces to an LIU. TNEG is used in conjunction with TPOS to provide dual rail NRZ (Non Return to Zero) data or dual rail RZ (Return to Zero) data. The clock at the TXCL pin is used to clock data out of the TNEG pin. Pins TNEG[0-7] are used for Framers[0-7] respectively.</p> <p>In T1 mode, line codes are selected with control bits: TZCS2-0, TPDV, TXB8ZS, RZNRZ and UNIBI (Address Y01). T1 mode is selected if the T1E0 bit (Address 900) is 1.</p> <p>In E1 mode, line codes are selected with control bits: COD0-1 and THDB3 (Address Y02). E1 mode is selected if the T1E0 bit (Address 900) is 0.</p>
8 28 48 68 88 108 132 148	E2 J4 P2 P8 R10 P16 J14 E16	TXCL[0] TXCL[1] TXCL[2] TXCL[3] TXCL[4] TXCL[5] TXCL[6] TXCL[7]	IO	<p>1.544/2.048 MHz Transmit Clock. This pin accepts/outputs a clock that is used to clock data out of the transmit side of the framer on pins TPOS and TNEG. If TPOS/TNEG are configured for RZ output then the rising edge of the clock is used to clock TPOS/TNEG data. If TPOS/TNEG are configured for NRZ output then either a rising or falling TxCL edge can be selected to clock TPOS/TNEG data. Pins TxCL[0-7] are used for Framers[0-7] respectively.</p> <p>In T1 mode this pin is an input. The 1.544MHz transmit clock is typically provided by an external PLL (Phase Lock Loop) or LIU. An active rising or falling edge is selected with the CLKE bit (Address Y01). See Figure 45.</p> <p>In E1 mode this pin is an output. The 2.048MHz transmit clock is synchronous with the 4.096MHz ST-BUS clock input to pin CKi. An active rising or falling edge is selected with the T2OP bit (Address Y02). See Figure 64.</p>

Pin Description (continued)

Pin #		Name	Type	Description (see Notes 1 to 7)
LQFP	LBGA			
9 29 49 69 89 109 128 149	E3 K1 P3 R5 R11 N13 J15 D13	RxDL[0] RxDL[1] RxDL[2] RxDL[3] RxDL[4] RxDL[5] RxDL[6] RxDL[7]	O	<p>Receive Data Link. The entire received data stream including framing bits, after B8ZS/HDB3 decoding, is clocked out of the RxDL pin by the clock at the EXCLi pin. RxDL data does not pass through the receive slip buffer. The embedded data link is flagged by RxDLC. Pins RxDL[0-7] are used for Framers[0-7] respectively.</p> <p>In T1 mode this is a 1.544Mbit/s data stream clocked out with the rising edge of the clock at the EXCLi pin.</p> <p>In E1 mode this is a 2.048 Mbit/s data stream clocked out with the falling edge of the clock at the EXCLi pin.</p>
10 30 50 70 90 110 129 150	E4 K2 P4 R6 R12 N14 J16 D14	RxDLC[0] RxDLC[1] RxDLC[2] RxDLC[3] RxDLC[4] RxDLC[5] RxDLC[6] RxDLC[7]	O	<p>Receive Data Link Clock. This pin outputs a clock that can be used to clock selected bits from the RxDL data stream into an external device. The RxDLC pin can also be configured as an enable signal. Pins RxDLC[0-7] are used for Framers[0-7] respectively.</p> <p>In T1 mode the FDL (Facility Data Link) bits embedded in the RxDL data stream can be clocked into an external device with the rising edge of this 4kHz clock. The rising edge of the clock is centered on the S-bit position and it is coincident with the falling edge of the clock provided to the EXCLi pin. The RxDLC pin can be configured as a clock or an enable signal with the DLCK bit (Address Y06). See Figure 42.</p> <p>In T1 IMA (Inverse Mux for ATM) mode the RxDLC pin outputs the same 1.544MHz clock that is input to the EXCLi pin. In IMA mode the DSTo data stream will be synchronous with this 1.544MHz clock. IMA mode is selected by setting the IMA bit (Address Y00) to 1. See Figure 32.</p> <p>In E1 mode the selected data link national bits (timeslot 0, bits 4-8 of the NFAS (Non-Frame Alignment Signal) frames) can be clocked into an external device with the rising edge of this clock. The Receive Data Link clock is a gapped 4, 8, 12, 16 or 20 kHz, clock as programmed by the Datalink Control Register (Address Y08), derived by gating the 2.048MHz clock provided to the EXCLi pin. The RxDLC pin can be configured as a clock or an enable signal with the DLCK bit (Address Y08). See Figure 62.</p> <p>In E1 IMA (Inverse Mux for ATM) mode the RxDLC pin provides an ST-BUS type 4.096MHz clock derived by doubling the 2.048MHz clock provided to the EXCLi pin. In IMA mode the DSTo data stream will be synchronous with this 4.096MHz clock. IMA mode is selected by setting the IMA bit (Address Y00) to 1. See Figure 51.</p>

Pin Description (continued)

Pin #		Name	Type	Description (see Notes 1 to 7)
LQFP	LBGA			
11 31 51 71 91 111 135 151	F1 K3 R1 R7 T9 N15 H13 D15	TxDL[0] TxDL[1] TxDL[2] TxDL[3] TxDL[4] TxDL[5] TxDL[6] TxDL[7]	I	<p>Transmit Data Link. This pin accepts data from an external device for the Transmit Data Link. Pins TxDL[0-7] are used for Framers[0-7] respectively.</p> <p>In T1 mode this pin accepts a 4kbit/s serial input stream that contains the ESF FDL (Facility Data Link) bits that are to be embedded in the transmit data stream. The data is clocked in by the rising edge of the clock provided at the TxDLC pin. TxDL data does not pass through the transmit slip buffer.</p> <p>In E1 mode this pin accepts a 4,8,12,16 or 20 kbit/s, as programmed by the Datalink Control Register (Address Y08), data stream which contains the data link national bits (timeslot 0, bits 4-8 of the NFAS (Non-Frame Alignment Signal) frames) for transmission. The selected data link national bits are clocked into the framer by the falling edge of the clock provided at the TxDLC pin.</p>
12 32 52 72 92 112 131 152	F2 K4 R2 R8 T10 N16 H14 D16	TxDLC[0] TxDLC[1] TxDLC[2] TxDLC[3] TxDLC[4] TxDLC[5] TxDLC[6] TxDLC[7]	O	<p>Transmit Data Link Clock. This pin provides a clock that is used to clock transmit data link data out of an external device into the TxDL pin. The TxDLC pin can also be configured as an enable signal. Pins TxDLC[0-7] are used for Framers[0-7] respectively.</p> <p>In T1 mode, this pin provides either a 4kHz clock derived by gating the 1.544MHz clock provided to the TxCL pin, or it provides an enable signal. The TxDLC pin can be configured as a clock or an enable signal with the DLCK bit (Address Y06). Transmit data link data does not pass through the transmit slip buffer. See Figure 40.</p> <p>In E1 mode, this pin provides either a gapped 4,8,12,16 or 20 kHz clock, as programmed by the Datalink Control Register (Address Y08), derived by gating the 2.048MHz clock provided to the TxCL pin, or it provides an enable signal. The TxDLC pin can be configured as a clock or an enable signal with the DLCK bit (Address Y08). See Figure 59.</p>

Pin Description (continued)

Pin #		Name	Type	Description (see Notes 1 to 7)
LQFP	LBGA			
13 33 53 73 93 113 133 153	F3 L1 R3 T5 T11 M13 H15 C13	$\overline{\text{RxMF}}[0]$ $\overline{\text{RxMF}}[1]$ $\overline{\text{RxMF}}[2]$ $\overline{\text{RxMF}}[3]$ $\overline{\text{RxMF}}[4]$ $\overline{\text{RxMF}}[5]$ $\overline{\text{RxMF}}[6]$ $\overline{\text{RxMF}}[7]$	O	<p>Receive Multiframe Boundary. This pin provides a pulse that identifies basic frame 0 (the start of bit cell 7 of channel 0) of each received multiframe on the ST-BUS data stream (DSTo). The $\overline{\text{RxMF}}$ pin operates the same way in 2.048Mbit/s and 8.196Mbit/s modes. Pins $\overline{\text{RxMF}}[0-7]$ are used for Framers[0-7] respectively.</p> <p>In T1 mode, the $\overline{\text{RxMF}}$ pulse is 244ns wide and its center identifies basic frame 0 of the received multiframe. If the Tx8KEN control bit (Address YF1) is 1 then the $\overline{\text{RxMF}}$ pin outputs an 8kHz frame pulse synchronous with the data stream on TPOS/TNEG. See Figure 36 and Figure 38.</p> <p>In T1 IMA mode, the frame pulse duration is 648ns.</p> <p>In E1 mode, (and E1 IMA mode) the $\overline{\text{RxMF}}$ pulse is 244ns wide and its center identifies basic frame 0 of the received CAS (Channel Associated Signaling) multiframe boundary or the received CRC-4 multiframe boundary as determined by the MFSEL control bit (Address Y02). If the Tx8KEN control bit (Address Y02) is 1 then the $\overline{\text{RxMF}}$ pin outputs an 8kHz frame pulse synchronous with the data stream on TPOS/TNEG. See Figure 55 and Figure 57.</p>
14 94	F4 T12	DSTi[0] DSTi[4]	I	<p>Data ST-BUS. This pin is an input for the transmit side of the framer. In 2.048Mbit/s ST-BUS mode and IMA mode it operates the same as DSTi(1-3), it can also operate in 8.192Mbit/s ST-BUS mode. IMA mode is not available at 8.192Mbit/s. The DSTi data stream is clocked into the framer by the clock input to pin CKi.</p> <p>When operated in 8.192Mbit/s ST-BUS mode this pin accepts a data stream containing 128 8-bit channels accommodating four framers. See Table 2 and Table 5. The frame boundary is indicated by the FPi inputs. Pin DSTi[0] is used by Framers[0-3] and pin DSTi[4] is used by Framers[4-7].</p> <p>In 8.192Mbit/s mode, the 32 ST-BUS channels mapped to each framer are treated as described for DSTi(1-3) operating at 2.048Mbit/s.</p>

Pin Description (continued)

Pin #		Name	Type	Description (see Notes 1 to 7)	
LQFP	LBGA				
34 54 74	L2 R4 T6	DSTi[1] DSTi[2] DSTi[3]	I	<p>Data ST-BUS. In 2.048Mbit/s ST-BUS mode and IMA mode this pin is an input for the transmit side of the framer. This pin is not used in 8.192Mbit/s ST-BUS mode. The DSTi data stream is clocked into the framer by the clock input to pin CKi. Pins DSTi[0-7] are used by Framers[0-7] respectively.</p> <p>In T1 mode, this pin accepts a 2.048Mbit/s ST-BUS stream. The first 24 ST-BUS channels contain the data to be transmitted on the PCM24 interface. See Table 1.</p> <p>In T1 IMA mode, this pin accepts a 1.544Mbit/s serial stream that contains a framing bit followed by the 24 8-bit channels to be transmitted on the PCM24 interface, see Table 3. The framing bit is ignored and an internally generated framing bit is used. IMA mode is selected by setting the IMA bit (Address Y00) to 1.</p> <p>In E1 mode, this pin accepts a 2.048Mbit/s ST-BUS stream that contains the data to be transmitted on the PCM30 interface. See Table 4 and Table 6.</p> <p>In E1 IMA mode, this pin accepts a 2.048Mbit/s ST-BUS stream that contains the data to be transmitted on the PCM30 interface. IMA mode is selected by setting the IMA bit (Address Y00) to 1. See Table 4 and Table 6.</p>	
114 134 154	M14 H16 C14	DSTi[5] DSTi[6] DSTi[7]			
15 95	G1 T13	DSTo[0] DSTo[4]	O		
					<p>Data ST-BUS. This pin is an output for the receive side of the framer. In 2.048Mbit/s ST-BUS mode and IMA mode it operates the same as DSTo(1-3), it can also operate in 8.192Mbit/s ST-BUS mode. IMA mode is not available at 8.192Mbit/s. The DSTo data stream is clocked out of the framer by the clock input to pin CKi.</p> <p>When operated in 8.192Mbit/s ST-BUS mode this pin outputs a data stream containing 128 8-bit channels accommodating four framers. See Table 2 and Table 5. The frame boundary is indicated by the FPi inputs. Pin DSTo[0] is used by Framers[0-3] and pin DSTo[4] is used by Framers[4-7].</p> <p>The 32 ST-BUS channels mapped to each framer are treated as described for DSTi(1-3) operating at 2.048Mbit/s.</p>

Pin Description (continued)

Pin #		Name	Type	Description (see Notes 1 to 7)	
LQFP	LBGA				
35 55 75	L3 T1 T7	DSTo[1] DSTo[2] DSTo[3]	O	<p>Data ST-BUS. In 2.048Mbit/s ST-BUS mode and IMA mode this pin is an output for the receive side of the framer. This pin is not used in 8.192Mbit/s ST-BUS mode. Pins DSTo[0-7] are used by Framers[0-7] respectively.</p> <p>In T1 mode, this pin outputs 2.048Mbit/s ST-BUS data. The first 24 channels contain the 24 8-bit channels received on the PCM24 interface. Channel 31 bit 0 contains the received S-bit in D4 and ESF modes. See Table 1. The DSTo data stream is clocked out of the framer by the clock input to pin CKi. The DSTo pin is enabled if the DSToEN control bit (Address YF1) is set to 1.</p> <p>In T1 IMA mode, this pin outputs the 1.544Mbit/s received serial stream. The serial stream contains the framing bit followed by the 24 8-bit channels received on the PCM24 interface. See Table 3. In IMA mode the DSTo data stream is clocked out of the framer by the clock output by the RxDLC pin. The DSTo pin is enabled if the DSToEN control bit (Address YF1) is set to 1. IMA mode is selected by setting the IMA bit (Address Y00) to 1.</p> <p>In E1 mode, this pin outputs 2.048Mbit/s ST-BUS data. The 32 channels contain the 32 channels of data received on the PCM30 interface. See Table 4 and Table 6. The DSTo data stream is clocked out of the framer by the clock input to pin CKi. The DSTo pin is enabled if the DSToE control bit (Address Y02) is set to 1.</p> <p>In E1 IMA mode, this pin outputs the 2.048Mbit/s received serial stream. See Table 4 and Table 6. In IMA mode the DSTo data stream is clocked out of the framer by the clock output by the RxDLC pin. The DSTo pin is enabled if the DSToE control bit (Address Y02) is set to 1. IMA mode is selected by setting the IMA bit (Address Y00) to 1.</p>	
115 130 155	M15 G13 C15	DSTo[5] DSTo[6] DSTo[7]			
16 96	G2 T14	CSTi[0] CSTi[4]	I		<p>Control ST-BUS. This pin is the signaling input for the transmit side of the framer. In 2.048 Mbit/s ST-BUS mode it operates the same as CSTi(1-3), it can also operate in 8.192Mbit/s ST-BUS mode. The CSTi data stream is clocked into the framer by the clock input to pin CKi. This pin has no function in IMA mode.</p> <p>When operated in 8.192Mbit/s ST-BUS mode this pin accepts a data stream containing 128 8-bit channels accommodating four framers. See Table 2 and Table 5. The frame boundary is indicated by the FPi inputs. Pin CSTi[0] is used by Framers[0-3] and pin CSTi[4] is used by Framers[4-7].</p> <p>The 32 ST-BUS channels mapped to each framer are treated as described for CSTi(1-3) operating at 2.048Mbit/s.</p>

Pin Description (continued)

Pin #		Name	Type	Description (see Notes 1 to 7)	
LQFP	LBGA				
36 56 76	L4 T2 T8	CSTi[1] CSTi[2] CSTi[3]	I	<p>Control ST-BUS. In 2.048Mbit/s ST-BUS mode this pin is the signaling input for the transmit side of the framer. This pin has no function in 8.192Mbit/s ST-BUS mode or IMA mode. Pins CSTi[0-7] are used by Framers[0-7] respectively. The CSTi data stream is clocked into the framer by the clock input to pin CKi.</p> <p>In T1 robbed bit signaling mode the first 24 ST-BUS channels contain (XXXXABCD) signaling nibbles to be transmitted for their respective DS0s. The least significant nibbles (bits 3-0) are valid and the most significant nibbles of each channel are ignored.</p> <p>In T1 CCS (Common Channel Signaling) mode, the CSTi pin can be connected to the output of an external multi-channel HDLC. Any one of the framer's transmit timeslots can be programmed to transmit the data appearing at the CSTi pin on any one of the first 24 ST-BUS channels. See the descriptions of the CSIGEN control bit (Address Y04) and the Common Channel Signaling Map Register (Address Y0B).</p> <p>In E1 CAS (Channel Associated Signaling) mode, the 32 ST-BUS channels contain (XXXXABCD) signaling nibbles to be transmitted for their respective timeslots. The least significant nibbles (bits 3-0) are valid and the most significant nibbles of each channel are ignored. See Table 28.</p> <p>In E1 CCS (Common Channel Signaling) mode, the CSTi pin can be connected to the output of an external multi-channel HDLC. The framer's transmit timeslots 15, 16 and 31 can each be programmed to transmit the data appearing at the CSTi pin on any one of the 32 ST-BUS channels. See the descriptions of the CSIG control bit (Address Y03) and the TS15E, TS16E and TS31E control bits (Address Y06) and see Table 30.</p>	
116 136 156	M16 G14 C16	CSTi[5] CSTi[6] CSTi[7]			
17 97	G3 T15	CSTo(0) CSTo[4]	OH		<p>Control ST-BUS. This pin is the signaling output for the receive side of the framer. In 2.048 Mbit/s ST-BUS mode it operates the same as CSTo(1-3), it can also operate in 8.192Mbit/s ST-BUS mode. The CSTo data stream is clocked out of the framer by the clock input to pin CKi. This pin has no function in IMA mode.</p> <p>When operated in 8.192Mbit/s ST-BUS mode this pin outputs a data stream containing 128 8-bit channels accommodating four framers. See Table 2 and Table 5. The CSTo[0] pin is used by Framers [0-3] and the CSTo[4] pin is used by Framers [4-7]. The frame boundary is indicated by the FPi inputs. FPi[0] is used for Framers[0-3] and FPi[4] is used for Framers[4-7].</p> <p>The 32 ST-BUS channels mapped to each framer are treated as described for CSTo(1-3) operating at 2.048Mbit/s.</p>

Pin Description (continued)

Pin #		Name	Type	Description (see Notes 1 to 7)	
LQFP	LBGA				
37 57 77	M1 T3 N9	CSTo[1] CSTo[2] CSTo[3]	OH	<p>Control ST-BUS. In 2.048Mbit/s ST-BUS mode this pin is the signaling output for the receive side of the framer. The CSTo data stream is clocked out of the framer by the clock input to pin CKi. This pin has no function in 8.192Mbit/s ST-BUS mode or IMA mode. Pins CSTo[0-7] are used by Framers[0-7] respectively.</p> <p>In T1 robbed bit signaling mode, the first 24 ST-BUS channels contain (XXXXABCD) signaling nibbles received for their respective DS0s. The least significant nibbles (bits 3-0) are valid and the most significant nibbles of each channel are in a high impedance state. The CSTo pin is enabled if the CSToEN control bit (Address YF1) is set to 1.</p> <p>In T1 CCS (Common Channel Signaling) mode, the CSTo pin can be connected to the input of an external multi-channel HDLC. Any one of the framer's receive timeslots be programmed to output their received data on the CSTo pin on any one of the first 24 ST-BUS channels. CSTo is in a high impedance state during unused channels. See the descriptions of the CSIGEN control bit (Address Y04) and the Common Channel Signaling Map Register (Address Y0B). The CSTo pin is enabled if the CSToEN control bit (Address YF1) is set to 1.</p> <p>In E1 CAS (Channel Associated Signaling) mode, the 32 ST-BUS channels contain (XXXXABCD) signaling nibbles received for their respective timeslots. The least significant nibbles (bits 3-0) are valid and the most significant nibbles of each channel are in a high impedance state. See Table 29. The CSTo pin is enabled if the CSToE control bit (Address Y02) is set to 1.</p> <p>In E1 CCS (Common Channel Signaling) mode, the CSTo pin can be connected to the input of an external multi-channel HDLC. The framer's receive timeslots 15, 16 and 31 can each be programmed to output their received data on the CSTo pin during any one of the 32 ST-BUS channels. CSTo is in a high impedance state during unused channels. See the descriptions of the CSIG control bit (Address Y03) and the TS15E, TS16E and TS31E bits (Address Y06) and see Table 152. The CSTo pin is enabled if the CSToE control bit (Address Y02) is set to 1.</p>	
117 137 157	L13 G15 B13	CSTo[5] CSTo[6] CSTo[7]			
18 98	G4 T16	CKi[0] CKi[4]	I		<p>System Clock. In 2.048Mbit/s ST-BUS mode and 8.192Mbit/s ST-BUS mode this pin accepts the clock that is used to time the transmit side and the receive side of the framer. The CKi clock rate is determined by control bits at (Address 900)</p> <p>In 2.048Mbit/s ST-BUS mode and in IMA mode, operation is the same as that described for pins CKi[1-3].</p> <p>In 8.192Mbit/s ST-BUS mode this pin accepts the ST-BUS type 16.384MHz clock that is used to time the 8.192Mbit/s data appearing at pins DSTi, CSTi, DSTo and CSTo. In this mode pin CKi[0] is used by framers[0-3] and pin CKi[4] is used by framers[4-7]. See Figure 26.</p> <p>8.192Mbit/s operation is not available in IMA mode.</p>

Pin Description (continued)

Pin #		Name	Type	Description (see Notes 1 to 7)
LQFP	LBGA			
38 58 78 118 138 158	M2 T4 N10 L14 G16 B14	CKi[1] CKi[2] CKi[3] CKi[5] CKi[6] CKi[7]	I	<p>System Clock. In 2.048Mbit/s ST-BUS mode this pin accepts the clock that is used to time the transmit side and receive side of the framer. In IMA mode it accepts the clock that is used to time the transmit side of the framer only. Pins CKi[0-7] are used to time Framers[0-7] respectively. The CKi clock rate is determined by control bits at (Address 900). This pin has no function in 8.192Mbit/s mode.</p> <p>In 2.048Mbit/s ST-BUS mode this pin accepts the ST-BUS type 4.096MHz clock that is used to time the data appearing at pins DSTi, CSTi, DSTo and CSTo. See Figure 24.</p> <p>In T1 IMA mode this pin accepts the 1.544MHz clock that is used to time the transmit data appearing at pin DSTi. IMA mode is selected by setting the IMA bit (Address Y00) to 1. See Figure 32.</p> <p>In E1 IMA mode this pin accepts the ST-BUS type 4.096MHz clock that is used to time the transmit data appearing at pins DSTi. IMA mode is selected by setting the IMA bit (Address Y00) to 1. See Figure 51.</p> <p>In T1/E1 IMA mode the receive data stream is clocked out of pin DSTo by the clock output by pin RxDLC.</p>
19 99	H1 R13	FPI[0] FPI[4]	I	<p>Frame Pulse. This pin accepts a frame pulse that sets the basic frame boundary for the transmit and receive sides of the framer. The clock rate is determined by control bits at (Address 900)</p> <p>In 2.048Mbit/s mode and in IMA mode, operation is the same as that described for pins FPI[1-3].</p> <p>In 8.192Mbit/s mode this pin accepts an 8.192Mbit/s ST-BUS type frame pulse which sets the frame boundary common to four framers. FPI[0] is used to set the frame boundary for Framers[0-3] and FPI[4] is used to set the frame boundary for Framers[4-7]. See Figure 26.</p> <p>8.192Mbit/s operation is not available in IMA mode.</p>

Pin Description (continued)

Pin #		Name	Type	Description (see Notes 1 to 7)	
LQFP	LBGA				
39 59 79	M3 N5 N11	FPI[1] FPI[2] FPI[3]	I	<p>Frame Pulse. This pin accepts a frame pulse that sets the basic frame boundary for the transmit and receive sides of the framer. In IMA mode it accepts a frame pulse that sets the basic frame boundary for the transmit side of the framer only. Pins FPI[0-7] are used to set the frame boundaries for Framers[0-7] respectively. The clock rate is determined by control bits at (Address 900). This pin has no function in 8.192 Mbit/s mode.</p> <p>In 2.048Mbit/s ST-BUS mode this pin accepts an ST-BUS 2.048Mbit/s frame pulse that sets the basic frame boundary for the data that appears at pins DSTi, DSTo, CSTi and CSTo. See Figure 24.</p> <p>In T1 IMA mode, this pin accepts a 648ns frame pulse that sets the basic frame boundary for the transmit data that appears at pin DSTi. IMA mode is selected by setting the IMA bit (Address Y00) to 1. See Figure 32.</p> <p>In E1 IMA mode, this pin accepts a 2.048 Mbit/s ST-BUS type frame pulse that sets the basic frame boundary for the transmit data that appears at pin DSTi. IMA mode is selected by setting the IMA bit (Address Y00) to 1. See Figure 51.</p> <p>In T1 IMA mode and E1 IMA mode, the basic frame boundary for the receive data stream that is output by DSTo is indicated by the clock output by the RxBF pin.</p>	
119 139 159	L15 F13 B15	FPI[5] FPI[6] FPI[7]			
20 40 60 80 100 120 140 160	H2 M3 N6 N12 R14 L16 F14 B16	$\overline{\text{RxBF}}[0]$ $\overline{\text{RxBF}}[1]$ $\overline{\text{RxBF}}[2]$ $\overline{\text{RxBF}}[3]$ $\overline{\text{RxBF}}[4]$ $\overline{\text{RxBF}}[5]$ $\overline{\text{RxBF}}[6]$ $\overline{\text{RxBF}}[7]$	O		<p>Receive Basic Frame Pulse. This pin outputs a frame pulse that indicates the basic frame boundary for the received data stream output by the RxDL pin. In IMA mode the receive basic frame pulse also indicates the basic frame boundary in the received data stream output by the DSTo pin. Pins RxBF[0-7] are used to set the frame boundaries for Framers[0-7] respectively.</p> <p>In T1 mode, this pin provides a basic frame pulse that indicates the S-bit in the 1.544Mbit/s received data stream output by pin RxDL. See Figure 44.</p> <p>In T1 IMA mode, the Receive Basic Frame Pulse indicates the S-bit in the 1.544Mbit/s received data stream output by pin DSTo. IMA mode is selected by setting the IMA bit (Address Y00) to 1. See Figure 32.</p> <p>In E1 mode, this pin provides a 2.048 Mbit/s ST-BUS type frame pulse that indicates the beginning of channel 0 in the 2.048Mbit/s received data stream output by the RxDL pin. See Figure 61.</p> <p>In E1 IMA mode, the receive basic frame pulse indicates the beginning of channel 0 in the 2.048Mbit/s received data stream output by the DSTo pin. IMA mode is selected by setting the IMA bit (Address Y00) to 1. See Figure 51.</p>

Pin Description (continued)

Pin #		Name	Type	Description (see Notes 1 to 7)
LQFP	LBGA			
163-178	A13,A14, A15,A16, B12,A12, C12,D12, A11,B11, C11,D11, C10,D10, B10,A10	D0-D15	I/O	Data 0 to 15. These 16 signals form the bidirectional data bus for the non-multiplexed parallel processor interface. D15 is the most significant bit.
181-192	B9,A9,C9, D9,B8,C8, A8,D8,D7, B7,C7,A7	A0-A11	I	Address 0 to 11. These 12 signals form the input address bus for the non-multiplexed parallel processor interface. Bits A10 and A8 determine which of the eight framers is selected for read and write operations, bit A11 being high and A8 to A10 being low selects all eight framers for write operations. A11 and A8 being both high and A9 being low selects global control registers. A11 is the most significant bit.
193	A6	\overline{CS}	I	Chip Select. A zero enables the read and write functions of the MT9072 parallel processor interface; all bidirectional data bus lines (D0-D15) will operate normally. A one disables the read and write functions of the parallel processor interface; all bidirectional data bus lines (D0-D15) will be in a high impedance state.
194	D6	\overline{DS}	I	Data Strobe. Data Strobe for Motorola mode ($I/\overline{M}=0$). The MT9072 reads data from the address bus (A0-A11) on the falling edge of \overline{DS} ; writes data to the bidirectional data bus (D0-D15) on the falling edge of \overline{DS} (processor read); reads data from the bidirectional data bus (D0-D15) on the falling edge of \overline{DS} (processor write). \overline{DS} may be connected to \overline{CS} .
	D6	(\overline{RD})	I	Read. Read for Intel type mode ($I/\overline{M}=1$). The MT9072 reads data from the address bus (A0-A11) on the falling edge of \overline{RD} ; writes data to the bidirectional data bus (D0-D15) on the falling edge of \overline{RD} (processor read).
195	B6	R/\overline{W}	I	Read/Write. Read and Write for Motorola mode ($I/\overline{M}=0$). A zero sets the MT9072 bidirectional data bus lines (D0-D15) as inputs for a processor write. A one sets the MT9072 bidirectional data bus lines (D0-D15) as outputs (processor read).
	B6	(\overline{WR})	I	Write. Write for Intel type mode ($I/\overline{M}=1$). The MT9072 reads data from the address bus (A0-A11) on the falling edge of \overline{WR} ; reads data from the bidirectional data bus (D0-D15) on the rising edge of \overline{WR} (processor write).
196	C6	\overline{IRQ}	OH	Interrupt Request. When zero, one or more of the eight framers in the MT9072 has generated an interrupt request. When one, the MT9072 has not generated an interrupt request. \overline{IRQ} is an open drain output that should be connected to V_{DD} through a pull-up resistor. \overline{CS} can be either high or low for this output pin to function.
197	D5	\overline{IM}	I	Intel / Motorola. High configures the processor interface for Intel type of parallel non-multiplexed processors where \overline{RD} and \overline{WR} pins are used. Low configures the processor interface for Motorola type of parallel non-multiplexed processors where R/\overline{W} and \overline{DS} pins are used. See Figure 22 and Figure 23.

Pin Description (continued)

Pin #		Name	Type	Description (see Notes 1 to 7)
LQFP	LBGA			
198	C5	$\overline{\text{RESET}}$	I	Reset. When zero, all eight framers of the MT9072 are in a reset condition where all registers are set to their default values. When one, all eight framers of the MT9072 operate normally where all registers may be programmed by the external processor. A valid reset condition requires this input to be held low for a minimum of 100ns. This input should be set to zero during initial power up, then set to one.
199	A5	$\overline{\text{TAIS}}$	I	Transmit Alarm Indication Signal. When zero, all eight framers of the MT9072 transmit an all ones signal (AIS) at the TPOS and TNEG output pins. When one, all eight framers of the MT9072 transmit data normally. This input is typically set to zero during initial power up, then set to one.
200	B5	$\overline{\text{TxFM}}$	I	Transmit Multiframe Boundary. This pin accepts a frame pulse that sets the multiframe boundary for the framer transmitters. The device will generate its own multiframe boundary if this pin is held high. The $\overline{\text{TxFM}}$ pin is held high in most applications. This input is common for all eight framers, and is enabled on a per framer basis with a control register bit. Operation is identical in 2.048 Mbit/s and 8.192 Mbit/s modes. In T1 mode the frame pulse applied to this pin sets the transmitted D4/ESF multiframe boundary. The falling edge of this frame pulse identifies basic frame 0 on the ST-BUS data stream (DSTi). This input is enable with control bit TxMFSEL (Address YF1). See Figure 34. In E1 mode the frame pulse applied to this pin sets the transmitted channel associated signaling (CAS) multiframe boundary or the transmitted CRC-4 multiframe boundary. The falling edge of this frame pulse identifies basic frame 0 on the ST-BUS data stream (DSTi) of the 16 frame multiframe. This input is enabled with control bit MFBE (Address Y02). See Figure 53.
201	A4	RSV	--	This pin should be tied low.
202	B4	RSV	--	This pin should be tied low.
203	C4	RSV	--	This pin should be tied low.
204	A3	TDI	IPu	Test Data Input. One of five signals (TDI, TDO, TMS, TCK & $\overline{\text{TRST}}$) making up the Test Access Port (TAP) of the IEEE 1149.1-1990 Standard Test Port and Boundary-Scan Architecture. The TAP provides access to test support functions built into the MT9072. The TAP is also referred to as a JTAG (Joint Test Action Group) port.
205	A2	TDO	OH	Test Data Output. Depending on the sequence previously applied to the TMS input, the contents of either the instruction register or data register are serially shifted out towards the TDO. The data out of the TDO is clocked on the falling edge of the TCK pulses. When no data is shifted through the boundary scan cells, the TDO driver is set to a high impedance state. See the pin description for TDI and the section on JTAG.

Pin Description (continued)

Pin #		Name	Type	Description (see Notes 1 to 7)
LQFP	LBGA			
206	B3	TMS	IPu	Test Mode Select Input. The logic signals received at the TMS input are interpreted by the TAP Controller to control the test operations. The TMS signals are sampled at the rising edge of the TCK pulse. Internally pulled up to V_{DD} . See the pin description for TDI and the section on JTAG.
207	B2	TCK	IPu	Test Clock Input. TCK provides the clock for the test logic. The TCK does not interfere with any on-chip clocks and thus remains independent. The TCK permits shifting of test data into or out of the Boundary-Scan register cells concurrently with the operation of the device and without interfering with the on-chip logic. Internally pulled up to V_{DD} . See the pin description for TDI and the section on JTAG. See Figure 70.
208	C3	$\overline{\text{TRST}}$	IPu	Test Reset. When zero, the JTAG scan structure is reset. When one, the JTAG scan structure operates normally. Internally pulled up to V_{DD} . See the pin description for TDI and the section on JTAG. A valid device reset condition requires this input to be held low for a minimum of 100ns. This input is should be set to zero during initial power up, then set to one if the JTAG port is to be used, otherwise, it may be permanently set to zero.
--	B1	RSV	--	This pin should be tied low.

Notes:

- All inputs are CMOS with CMOS compatible logic levels.
- All unused inputs should be tied low.
- All outputs are CMOS and are compatible with CMOS logic levels.
- See AC Electrical Characteristics - Timing Parameter Measurement Voltage Levels for input and output voltage thresholds.
- The number enclosed in parentheses following the pin name identifies the framer as follows:
[0] - framer 0, [1] - framer 1, [2] - framer 2,... [7] - framer 7
- The "Y" character in the register address symbolizes the upper 4 address bits ($A_{11}A_{10}A_9A_8$) which identify the particular framer addressed within the MT9072 as follows:
[0] 0000 - framer 0, [1] 0001 - framer 1,... [2] 0010 - framer 2,... [7] 0111 - framer 7
[8] 1000 - all 8 framers.
- Pin types are as follows:
 - I - input(5 V tolerant input
 - IP - input with a pullup or pulldown, these are 3 V tolerant inputs.
 - O - output
 - I/O - input and output
 - OH - output and high impedance
 - OD - output open drain

Table of Contents

Figure 1 -Functional Block Diagram	1
Figure 2 -Pin Connections (Jedec MS-026)	10
Figure 3 -256 PIN LBGAs (Jedec MO-192).....	11
1.0 Overview	38
1.1 Standards Compliance.....	38
1.2 Microprocessor Port.....	38
1.3 Interface to the Physical Layer Device.....	38
1.4 Interface to the System Backplane.....	38
1.5 Framing Modes	38
1.6 Access to the Maintenance Channel.....	39
1.7 Robbed Bit Signaling/Channel Associated Signaling.....	39
1.8 Common Channel Signaling.....	39
1.9 HDLCs.....	39
1.10 Performance Monitoring and Debugging.....	39
2.0 PCM24 Interface (T1).....	40
2.1 T1 Interface to the System Backplane	40
Figure 4 -PCM24 Link Frame Format (T1)	40
Figure 5 -ST-BUS Format.....	40
Table 1 -ST-BUS vs. PCM24 Channel Relationship for 2.048 Mbit/s DST/CST Streams (T1)	41
Table 2 -ST-BUS Channel vs. PCM24 Channel Relationship for 8.192 Mbit/s DST/CST Streams (T1).....	41
Table 3 -ST-BUS vs. PCM24 to Channel Relationship for IMA DST Streams (T1).....	41
2.2 T1 Interface to the Physical Layer Device.....	42
2.3 T1 Line Coding.....	42
2.4 T1 Pulse Density	42
3.0 PCM30 Interface (E1).....	42
3.1 E1 Interface to the System Backplane	42
Table 4 -ST-BUS Channel vs. PCM30 Timeslot for 2.048 Mbit/s DST/CST Streams (E1)	43
Table 5 -ST-BUS Channel vs. PCM30 Timeslot Relationship for 8.192 Mbit/s DST/CST Streams (E1)	43
Table 6 -PCM30 Timeslot to PCM30 Channel Relationship (E1).....	43
Figure 6 -PCM30 Format (E1).....	44
3.2 E1 Interface to the Physical Layer Device.....	44
4.0 Framing	44
4.1 T1 Framing.....	44
Table 7 -Registers Related to Framing Mode for the MT9072 (T1).....	45
4.1.1 T1 D4 Framing.....	45

Table of Contents (continued)

Table 8 -D4 Superframe Structure (T1).....	46
4.1.2 T1 ESF Framing	46
Table 9 -ESF Superframe Structure (T1)	46
4.1.3 T1 T1DM Framing	47
4.1.4 T1 G.802 Mode.....	47
Table 10 -G.802 ST-BUS to PCM24 Mapping (T1).....	47
4.2 E1 Framing.....	48
Table 11 -Registers Related to Framing for MT9072 (E1)	48
4.2.1 E1 Basic Framing (Timeslot 0)	49
4.2.2 E1 CRC-4 Multiframing (Timeslot 0).....	49
Table 12 -CRC-4 FAS and NFAS Structure (E1)	50
4.2.2.1..... E1 Automatic CRC-4 Interworking 51	
Table 13 -Operation of AUTC, ARAI and TALM Control Bits (E1)	51
4.2.3 E1 Channel Associated Signaling (CAS) Multiframing (Timeslot 16).....	51
4.2.4 E1 Framing Algorithm.....	51
4.2.4.1..... Notes for Synchronization State Diagram (Figure 7) 52	
Figure 7 -Synchronization State Diagram (E1).....	53
5.0 Elastic Buffer	53
Figure 8 -Read and Write Pointers in the Slip Buffers.....	54
Table 14 - Registers Related to the Elastic Buffer (T1).....	55
Table 15 -Registers Related to Elastic Store (E1).....	55
5.1 Transmit Elastic Buffer	55
6.0 Data Link.....	56
6.1 T1 Data Link.....	56
Table 16 -Registers Related to the Data Link and Bit Oriented Messages (T1).....	56
6.1.1 T1 Data Link (DL) Pin Access	57
6.1.1.1..... T1 Data Link (DL) Pin Data Received from PCM24 57	
6.1.1.2..... T1 Data Link (DL) Pin Data Sent to PCM24 57	
6.2 E1 Data Link (DL) Operation	57
Table 17 - Data Link and Sa bits Configuration and Status Registers (E1).....	58
6.2.1 E1 Data Link (DL) Pin Access	58
6.2.1.1..... E1 Data Link (DL) Pin Data Transmitted on PCM30 58	
6.2.1.2..... E1 Data Link (DL) Pin Data Received on PCM30 - With No Elastic Buffer 58	
6.2.1.3..... E1 Data Link (DL) Pin Data Received on PCM30 - With Elastic Buffer 59	
6.2.2 E1 Data Link (DL) National Bit Buffer Access	59
Table 18 -MT9072 National Bit Buffers (E1).....	59
6.2.3 E1 Data Link (DL) ST-BUS Access	59
Table 19 -Transmit PCM30 National Bits from ST-BUS 2.048Mbit/s or 8.192Mbit/s DSTi (E1).....	60
6.2.4 E1 Timeslot 0 CRC-4 NFAS Receive from PCM30 to DSTo.....	60

Table of Contents (continued)

Table 20 -Receive PCM30 National Bits to ST-BUS 2.048Mbit/s or 8.192Mbit/s DSTo (E1)..... 60
 6.3 T1 Bit Oriented Message60
 Table 21 -T1.403 and T1.408 Message Oriented Performance Report Structure (T1) 61

7.0 Signaling 62

7.1 T1 Signaling 62
 7.1.1 T1 Robbed Bit Signaling..... 62
 Table 22 - Registers Related to Signaling (T1) 63
 7.1.2 T1 Common Channel Signaling..... 63
 7.2 E1 Signaling 63
 7.2.1 Channel Associated Signaling (CAS) Operation 63
 Table 23 -Registers Related to CAS Signaling (E1)..... 64
 Table 24 -Channel Associated Signaling (CAS) Multiframe Structure (E1)..... 65
 7.2.2 E1 Channel Associated Signaling (CAS) Register and ST-BUS Access 65
 7.2.2.1..... E1 Channel Associated Signaling (CAS) Transmit from ST-BUS CSTi to PCM30 66
 Table 25 -Transmit PCM30 CAS Channels 1 to 30 from ST-BUS 2.048Mbit/s or 8.192Mbit/s CSTi (E1) 66
 7.2.2.2..... E1 Channel Associated Signaling (CAS) Receive from PCM30 to ST-BUS CSTo 66
 Table 26 -Receive PCM30 CAS Channels 1 to 30 to ST-BUS 2.048Mbits or 8.192Mbits CSTo (E1) 66
 7.2.3 E1 Common Channel Signaling (CCS) Transmit from ST-BUS CSTi and DSTi to PCM30 66
 Table 27 -Transmit PCM30 CCS from ST-BUS 2.048Mbit/s or 8.192Mbit/s CSTi (E1) 67
 Table 28 -Transmit PCM30 CCS from ST-BUS 2.048Mbit/s or 8.192Mbit/s DSTi (E1) 67
 7.2.4 E1 Common Channel Signaling (CCS) Receive from PCM30 to CSTo and DSTo..... 67
 Table 29 -Receive PCM30 CCS to ST-BUS 2.048Mbit/s or 8.192Mbit/s CSTo (E1) 68
 Table 30 -Receive PCM30 CCS to ST-BUS 2.048Mbit/s or 8.192Mbit/s DSTo (E1) 68
 7.2.5 CCS (Timeslot 16) Programming Options Summary Table..... 69
 Table 31 -CCS (Timeslot 15, 16 & 31) Source and Destination Summary Table (E1)..... 69

8.0 HDLC70

Table 32 - HDLC Related Registers 70
 8.1 HDLC Description..... 70
 8.1.1 HDLC Frame Structure 71
 Table 33 - HDLC Frame Format..... 71
 8.1.2 Data Transparency (Zero Insertion/Deletion) 71
 8.1.3 Invalid Frames 71
 8.1.4 Frame Abort..... 71
 8.1.5 Interframe Time Fill and Link Channel States 72
 8.1.6 Go-Ahead 72
 8.1.7 Functional Description 72
 8.1.8 HDLC Transmitter..... 72
 8.1.9 HDLC Receiver..... 73

Table of Contents (continued)

9.0	MT9072 Access and Control	74
9.1	Processor Interface (A11-A0, D15-D0, I/M, DS, R/W, CS, IRQ, Pins)	74
9.1.1	Framer and Register Access	74
Table 34	-Framer and Register Access	75
9.1.1.1 CS and IRQ	75
9.1.2	ST-BUS Interface (DSTi, DSTo, CSTi, CSTo Pins).....	75
9.1.3	IMA Interface (DSTi, DSTo, Pins).....	75
Table 35	-Registers Related to IMA Mode	76
9.1.4	Signaling Multiframe Boundary (RxMF, TxMF Pins)	76
9.1.5	Control Pins	76
9.1.5.1 Reset Operation (RESET Pin, RST Bit and RSTC Bit)	76
Table 36	-Reset Status (T1)	77
Table 37	-Reset Status (E1)	78
9.1.5.2 Transmit AIS Operation (TAIS Pin)	78
9.1.5.3 IEEE 1149.1-1990 Test Access Port (TAP)	79
9.1.6	Data Link (DL) Interface (RxDL, RxDLC, TxDL, TxDLC Pins).....	79
9.1.7	Multiframe Boundary (RxMF, TxMF Pins)	79
10.0	ST-BUS Analyzer	79
11.0	Loopbacks	79
11.1	T1 Loopbacks.....	79
Table 38	-Registers Related to Loopbacks (T1)	81
11.2	T1 In Band Loopback Codes	81
Table 39	-Registers Related to In Band Loopbacks (T1)	81
11.3	E1 Loopbacks.....	82
Table 40	-Register Related to Setting Up Loopbacks (E1).....	82
12.0	Performance Monitoring	84
12.1	T1 Error Counters.....	84
Table 41	-Error Counters Summary (T1).....	84
12.2	E1 Error Counters	84
Table 42	-Registers Required for Observing and Clearing Error Counters (E1)	85
Table 43	-Error Counter and Event Dependency (E1)	86
13.0	Maintenance and Alarms	86
13.1	T1 Maintenance and Alarms	86
13.1.1	T1 Error Insertion.....	86
13.1.2	T1 Per Timeslot Control.....	86

Table of Contents (continued)

13.1.3 T1 Per Timeslot Looping	86
13.1.4 T1 Pseudo-Random Bit Sequence (PRBS) Testing	86
Table 44 -Registers Related to PRBS Testing (T1).....	87
13.1.5 T1 Mu-law Milliwatt.....	87
Table 45 -Mu Law Digital Milliwatt Pattern (T1).....	88
13.1.6 T1 Alarms	88
Table 46 -Alarm Control and Status Bits (T1).....	88
13.1.7 T1 Per Timeslot Trunk Conditioning.....	89
13.2 E1 Maintenance and Alarms	89
Table 47 -Registers Related to Maintenance and Alarms (E1)	89
13.2.1 E1 Error Insertion	90
13.2.2 E1 Per Timeslot Control	90
13.2.3 E1 Per Timeslot Looping	90
13.2.4 E1 Pseudo-Random Bit Sequence (PRBS) Testing.....	90
13.2.5 E1 A-law Milliwatt	91
Table 48 -A-Law Digital Milliwatt Pattern (E1)	91
13.2.6 E1 Alarms.....	91
Table 49 -Alarms and Timers Status Registers (E1).....	92
13.2.7 E1 Automatic Alarms	92
14.0 Interrupts.....	92
Figure 9 -Interrupt Status Registers	93
14.1 Interrupt Status Register Overview	93
14.1.1 Interrupt Related Control Bits and Pins	94
14.2 Interrupt Servicing Methods	94
14.2.1 Polling Method.....	94
14.2.2 Vector Method	94
14.3 T1 Interrupt Vector and Interrupt Source Summary	95
Table 50 -Interrupt Vector and Interrupt Source Summary (T1).....	95
14.4 E1 Interrupt Vector and Interrupt Source Summary.....	96
Table 51 -Interrupt Vector and Interrupt Source Summary (E1).....	96
14.5 E1 Interrupt Source and Interrupt Status Register Summary.....	98
Table 52 -Interrupt Source & Status Register Summary (E1)	98
15.0 JTAG (Joint Test Action Group) Operation.....	99
Figure 10 -Boundary Scan Test Circuit Block Diagram.....	100
15.1 Test Access Port (TAP).....	100
15.2 Test Access Port (TAP) Controller	101
15.3 Instruction Register	101
Table 53 -JTAG Instruction Register	101

Table of Contents (continued)

15.4	JTAG Data Registers	101
15.4.1	Identification Register	101
Table 54	-JTAG MT9072 Identification Register	101
15.4.2	The Bypass Register	102
Table 55	-JTAG Boundary-Scan Register	102
15.5	Boundary Scan Description Language (BSDL) File	102
16.0	MT9072 Register Set	103
16.1	T1 Register Set	103
16.1.1	Register Address (000 - FFF) Summaries.....	103
16.1.1.1 Framer Address (0XX-9XX) Summary	103
Table 56	-Framer Addressing (0XX - 9XX) (T1)	103
16.1.1.2 Register Group Address (Y00 - YFF) Summary	104
Table 57	-Register Group Address (Y00 - YFF) Summary (T1)	104
16.1.1.3 Global Control and Status Register (900-91F) Summary	105
Table 58	-Global Control and Status (900 - 91F) Summary (T1)	105
16.1.1.4 Master Control Registers Address (Y00-Y0F, YF0 to YFF) Summary	106
Table 59	- Master Control Registers Address (Y00 to Y0F and YF0 to YFF) Summary (T1).....	106
16.1.1.5 Master Status Registers Address (Y10-Y1F) Summary	108
Table 60	-Master Status Register(R) Address(Y1X) Summary (T1)	108
16.1.1.6 Latched Status Registers Address (Y20-Y2F) Summary	109
Table 61	-Latched Status Register (R) Address (Y2X) Summary (T1).....	109
16.1.1.7 Interrupt Status Registers Address (Y30-Y3F) Summary	110
Table 62	-Interrupt Status Register (R) Address (Y3X) Summary (T1)	110
16.1.1.8 Interrupt Mask Registers Address (Y40-Y4F) Summary	111
Table 63	-Interrupt Mask Register (R/W) Address (Y4X) Summary (T1)	111
16.1.2	Master Control Registers (Y00 to YF0) Bit Functions	112
Table 64	-Framing Mode Select (R/W Address Y00) (T1).....	112
Table 65	- Line Interface and Coding Word(Y01) (T1)	114
Table 66	- Transmit Alarm Control Word(Y02) (T1)	115
Table 67	-Transmit Error Control Word(Y03) (T1).....	115
Table 68	-Signaling Control Word (Y04) (T1)	116
Table 69	-LoopBack Control Word (Y05) (T1).....	117
Table 70	- HDLC & DataLink Control Word(Y06) (T1)	118
Table 71	-Transmit Bit Oriented Message Register (Y07) (T1)	118
Table 72	-Receive Bit Oriented Message Match Register(Y08) (T1)	119
Table 73	-Receive Idle Code Register(Y09) (T1)	119
Table 74	-Transmit Idle Code Register(Y0A) (T1).....	119
Table 75	-Common Channel Signaling Map Register(Y0B) (T1)	119
Table 76	-Transmit Loop Activate Code Register(Y0D) (T1).....	120
Table 77	-Transmit Loop Deactivate Code Register(Y0E) (T1).....	120
Table 78	-Receive Loop Activate Code Match Register(Y0F) (T1)	121
Table 79	-Receive Loop Deactivate code Match Register (R/W Address YF0)	121
16.1.3	Master Status Registers(Y10-Y18)Bit Functions	122

Table of Contents (continued)

Table 80 -Synchronization and Alarm Status Word(Y10) (T1)	122
Table 81 -Timer Status Word(Y11) (T1)	123
Table 82 -Receive Bit Oriented Message(Y12) (T1)	123
Table 84 -Transmit Slip Buffer Status Word(Y14) (T1).....	124
Table 83 -Receive Slip Buffer Status Word(Y13) (T1).....	124
Table 85 -PRBS Error Counter and CRC Multiframe Counter for PRBS(Y15) (T1)	125
Table 86 -Multiframe Out of Frame Counter(Y16) (T1)	125
Table 87 -Framing Bit Error Counter(Y17) (T1).....	125
Table 88 -Bipolar Violation Counter(Y18) (T1)	125
Table 89 -CRC-6 Error Counter(Y19) (T1)	125
Table 90 -Out of Frame and Change of Frame Counters(Y1A) (T1).....	125
Table 91 -Excessive Zero Counters(Y1B) (T1)	126
Table 92 - Transmit Byte Counter Position and HDLC Test Status(Y1C) (T1).....	126
Table 93 -HDLC Status Word(Y1D) (T1).....	127
Table 94 -HDLC Receive CRC(Y1E) (T1)	127
Table 95 - Receive FIFO(Y1F) (T1).....	127
16.1.4 Latched Status Registers (Y20 - Y2F) Bit Functions	128
Table 96 -HDLC Status Latch(Y23) (T1)	128
Table 97 -Receive Sync and Alarm Latch(Y24) (T1).....	129
Table 98 -Receive Line Status and Timer Latch(Y25) (T1)	130
Table 100 -Framing Bit Error Count Latch(Y28) (T1)	131
Table 101 - Bipolar Violation Count Latch(Y29) (T1).....	131
Table 102 -CRC-6 Error Count Latch(Y2A) (T1)	131
Table 99 -Elastic Store and Excessive Zero Status Latch(Y26) (T1)	131
Table 103 -Out of Frame Count and Change of Frame Count Latch(Y2B) (T1)	132
Table 104 - Multiframe Out of Frame Count Latch(Y2C) (T1)	132
16.1.5 Interrupt Status Registers (Y30 - Y3F) Bit Functions.....	133
Table 105 -HDLC Interrupt Status Register(Y33) (T1)	133
Table 106 -Receive Synchronization and Alarm Interrupt Status Register(Y34) (T1)	134
Table 107 -Receive Line and Timer Interrupt Status (Y35) (T1)	135
Table 108 -Elastic Store and Excessive zero Interrupt Status Register(Y36) (T1).....	136
16.1.6 Interrupt Mask Registers (Y40 - Y4F) Bit Functions	137
Table 109 -HDLC Interrupt Mask Register(Y43) (T1).....	137
Table 110 -Receive and Sync Interrupt Mask Register(Y44) (T1).....	137
Table 111 -Receive Line and Timer Interrupt Mask Register(Y45) (T1).....	139
Table 112 -Elastic Store and Excessive zero Interrupt Mask Register(Y46) (T1)	139
16.1.7 Per Channel Control and Data (Y50 - YAF) Bit Functions.....	140
Table 113 -Per Channel Transmit Signaling Y50-Y67 (T1)	140
Table 114 -Per Channel Receive Signaling Y70-Y87 (T1)	141
Table 115 -Per Channel Control Word(Y90-YA7) (T1).....	142
16.1.8 Master Control Registers (YF1 to YF7) Bit Functions	143
Table 116 -Interrupt and I/O Control(YF1) (T1)	143
Table 117 -HDLC Control 1(YF2) (T1)	144
Table 118 -HDLC Test Control(YF3) (T1)	145
Table 119 -Address Recognition Register(YF4) (T1)	146
Table 120 -TX Fifo Write Register(YF5) (T1)	146

Table of Contents (continued)

Table 121 -TX Byte Count Register(YF6) (T1)	146
Table 122 -TX Set Delay Bits (YF7) (T1).....	147
16.1.9 Global Control and Status Registers (900 - 91F) Bit Functions.....	148
Table 123 -Global Control0 Register (R/W Address 900) (T1).....	148
Table 124 -Global Control1 Register (R/W Address 901) (T1).....	148
Table 125 -Interrupt Vector 1 Mask Register (Address 902) (T1)	149
Table 126 -Interrupt Vector 2 Mask Register (Address 903) (T1)	150
Table 127 -Framer Loopback Global Register(904) (T1)	152
Table 128 -ST-Bus Interrupt Vector Mask(905) (T1)	152
Table 129 -Interrupt Vector 1 Status Register (Address 910) (T1).....	153
Table 130 -Interrupt Vector 2 Status Register (Address 911) (T1).....	154
Table 131 -Identification Revision Code Data Register (Address 912) (T1).....	155
Table 132 -ST-BUS Analyzer Vector Status Register (Address 913) (T1)	155
Table 133 -ST-BUS Analyser Data(Address 920-93F) (T1)	155
16.2 E1 Register Set	156
16.2.1 Register Address (000 - FFF) Summaries.....	156
16.2.1.1..... Framer Address (000-FFF) Summary	156
Table 134 -Framer Addressing (000 - FFF) (E1).....	156
16.2.1.2..... Register Group Address (Y00 - YFF) Summary	157
Table 135 -Register Group Address (Y00 - YFF) Summary (E1).....	157
16.2.1.3..... Global Control and Status Register (900-91F) Summary	158
Table 136 -Register Group Address (Y00 - YFF) Summary (E1).....	158
16.2.2 Register Address (Y00 - YFF) Summary.....	159
16.2.2.1..... Master Control Registers Address (Y00-Y0F, YF0-YFF) Summary	159
Table 137 -Master Control Register (R/W) Address (Y0X) Summary (E1)	159
16.2.2.2..... Master Status Registers Address (Y10-Y1F) Summary	160
Table 138 -Master Status Register (R) Address (Y1X) Summary (E1)	160
16.2.2.3..... Latched Status Registers Address (Y20-Y2F) Summary	161
Table 139 -Latched Status Register (R) Address (Y2X) Summary (E1)	161
16.2.2.4..... Interrupt Status Registers Address Summary(Y3X)	162
Table 140 -Interrupt Status Register (R) Address Summary (E1)	162
16.2.2.5..... Interrupt Mask Registers Address Summary(Y4X)	163
Table 141 -Interrupt Mask Register (R/W) Address Summary (E1)	163
16.2.2.6..... Transmit CAS Data Registers Address (Y50-Y6F) Summary	164
Table 142 -Transmit CAS Data Register (R/W) Address (Y5X,Y6X) Summary (E1)	164
16.2.2.7..... Receive CAS Data Registers Address (Y70-Y8F) Summary	165
Table 143 -Receive CAS Data Register (R) Address (Y7X,Y8X) Summary (E1).....	165
16.2.2.8..... Timeslot 0-31 Control Registers Address (Y90-YAF) Summary	166
Table 144 -Timeslot 0-31 Control Register (R/W) Address (Y9X, YAX) Summary (E1)	166
16.2.2.9..... Transmit National Bit Data Register(R/W) Address(YB0 to YB4) Summary	168
Table 145 -Transmit National Bits Data Registers (R/W) Address (YFX) Summary (E1)	168
16.2.2.10..... Receive National Bit Data Register(R/W) Address(YC0 to YC4) Summary	168
Table 146 -Transmit National Bits Data Registers (R/W) Address (YFX) Summary (E1)	168
16.2.3 Master Control Registers (Y00 - Y09) Bit Functions.....	169
Table 147 -Alarm and Framing Control Register Y00 (R/W Address Y00) (E1).....	169
Table 148 -Test, Error and Loopback Control Register (R/W Address Y01) (E1)	171

Table of Contents (continued)

Table 149 -Interrupts and I/O Control Register (R/W Address Y02) (E1).....	172
Table 150 -DL, CCS, CAS and Other Control Register (R/W Address Y03) (E1)	173
Table 151 -Signaling Period Interrupt Word (R/W Address Y04) (E1)	173
Table 152 -CAS Control and Data Register (R/W Address Y05) (E1).....	174
Table 153 - HDLC & CCS ST-BUS Control Register (R/W Address Y06) (E1).....	175
Table 154 -CCS to ST-BUS CSTi and CSTo Map Control Register (R/W Address Y07) (E1).....	176
Table 155 -DataLink Control Register (R/W Address Y08) (E1)	177
Table 156 -Receive Idle Code Register(Y09) (E1)	178
Table 157 -Transmit Idle Code Register(Y0A) (E1).....	178
16.2.4 Master Status Registers (Y10 - Y1A) Bit Functions.....	179
Table 158 -Synchronization & CRC-4 Remote Status (R Address Y10) (E1)	179
Table 159 -CRC-4 Timers & CRC-4 Local Status (R Address Y11) (E1).....	181
Table 160 -Alarms & Multiframe Signaling (MAS) Status (R Address Y12) (E1)	182
Table 161 -Non-Frame Alignment (NFAS) Signal and Frame Alignment Signal (FAS) Status (R Address Y13) (E1)	183
Table 162 -Phase Indicator Status (R Address Y14) (E1).....	184
Table 163 -PRBS Error Counter & PRBS CRC-4 Counter (R/W Address Y15) (E1).....	184
Table 164 -Loss of Basic Frame Synchronization Counter with Auto Clear (R/W Address Y16) (E1).....	185
Table 165 -E-bit Error Counter (R/W Address Y17) (E1)	185
Table 166 -Bipolar Violation (BPV) Error Counter (R/W Address Y18) (E1)	186
Table 167 -CRC-4 Error Counter (R/W Address Y19) (E1).....	186
Table 168 -Frame Alignment Signal (FAS) Bit Error Counter & FAS Error Counter (R/W Address Y1A) (E1) ...	187
Table 169 -Transmit Byte Counter Position and HDLC Test Status(Y1C) (E1)	187
Table 170 -HDLC Status Register(Y1D) (E1).....	188
Table 171 -HDLC Receive CRC(Y1E) (E1).....	188
Table 172 -HDLC Receive FIFO(Y1F) (E1).....	188
16.2.5 Latched Status Registers (Y2X) Bit Functions.....	189
Table 173 -HDLC Status Latch(Y23) (E1)	189
Table 174 -Sync, CRC-4 Remote, Alarms, MAS and Phase Latched Status Register (Address Y24) (E1)	189
Table 175 -Counter Indication and Counter Overflow Latched Status Register (Address Y25) (E1).....	191
Table 176 -CAS, National, CRC-4 Local and Timer Latched Status Register (Address Y26) (E1).....	192
Table 177 -Performance Persistent Latched Status Register (Address Y27) (E1).....	193
Table 178 -E-Bit Error Count Latch (R Address Y28) (E1).....	194
Table 179 -Bipolar Violation (BPV) Error Count Latch (R/W Address Y29) (E1).....	194
Table 180 -CRC-4 Error Count Latch (R/W Address Y2A) (E1).....	195
Table 181 -Frame Alignment Signal (FAS) Error Count Latch (R/W Address Y2B) (E1)	195
16.2.6 Interrupt Vector and Interrupt Status Registers (Y3X) Bit Functions	196
Table 183 -Sync, CRC-4 Remote, Alarms, MAS and Phase Interrupt Status Register (Address Y34) (E1).....	197
Table 184 -Counter Indication and Counter Overflow Interrupt Status Register (Address Y35) (E1)	198
Table 185 -CAS, National, CRC-4 Local and Timer Interrupt Status Register (Address Y36) (E1)	200
16.2.7 Interrupt Vector Mask and Interrupt Mask Registers (Y4X) Bit Functions	201
Table 186 -HDLC Interrupt Mask Register (Address Y43) (E1)	201
Table 187 -Sync (Sync, CRC-4 Remote, Alarms, MAS and Phase) Interrupt Mask Register (Address Y44) (E1)	202
Table 188 -Counter (Counter Indication and Counter Overflow) Interrupt Mask Register (Address Y45) (E1)...	203
Table 189 -National (CAS, National, CRC-4 Local and Timers) Interrupt Mask Register (Address Y46) (E1) ...	205

Table of Contents (continued)

16.2.8 Transmit CAS (ABCD) Data Registers (Y51 - Y6F) Bit Functions.....	207
Table 190 -Channel n, Transmit CAS Data Register (Address Y51-Y6F) (E1)	207
16.2.9 Receive CAS (ABCD) Data Registers (Y71 - Y8F) Bit Functions.....	208
Table 191 -Channel n, Receive CAS Data Register (Address Y71-Y8F).....	208
16.2.10 Timeslot 0-31 Control Registers (Y90 - YAF) Bit Functions	209
Table 192 -Timeslot (TS) n (n = 0 to 31) Control Register (Address Y90 (TS0) to YAF(TS31)) (E1).....	209
16.2.11 Transmit National Bit RN Data Registers (YB0- YB4) Bit Functions.....	210
Table 193 -Transmit National Bits (Sa4 - Sa8) TNn (n = 0 to 4) Data Register (R/W Address YB0 to YB4) (E1).....	210
16.2.12 Receive National Bit RN Data Registers (YC0- YC4) Bit Functions	211
Table 194 -Receive National Bits (Sa4 - Sa8) RNn (n = 0 to 4) Data Register (R/W Address YC0 to YC4) (E1).....	211
16.2.13 Master Control Registers (YF0 - YF6) Bit Functions.....	212
Table 195 -HDLC Control1(YF2) (E1)	212
Table 196 -HDLC Test Control(YF3) (E1)	213
Table 197 -TX Fifo Write Register(YF5) (E1)	213
Table 198 -TX Byte Count Register(YF6) (E1).....	214
16.2.14 Global Control and Status Registers(900-91F) Bit Functions.....	215
Table 199 -Global Control0 Register (R/W Address 900) (E1).....	215
Table 200 -Global Control1 Register (R/W Address 901) (E1).....	215
Table 201 -Interrupt Vector 1 Mask Register (R/W Address 902) (E1)	216
Table 202 -Interrupt Vector 2 Mask Register (R/W Address 903) (E1)	217
Table 203 -Framer Loopback Global Register(904) (E1)	219
Table 204 -Framer 0 ST-Bus Interrupt Vector Mask(905) (E1)	219
Table 205 -Interrupt Vector 1 Status Register (R/W Address 910) (E1).....	220
Table 206 -Interrupt Vector 2 Status Register (Address 911) (E1).....	221
Table 207 -Identification Revision Code Data Register (R Address 912) (E1).....	222
Table 208 - ST-Bus Analyser Vector Status Register (Address 913) (E1)	222
Table 209 -ST-BUS Analyser Data (Address 920-93F) (E1).....	222
17.0 Applications	223
Figure 11 -8 T1/E1 Links with Synchronous Common Channel Signaling	223
Figure 12 -8 T1/E1 Links with Synchronous Data Link Signaling	224
Figure 13 -8 T1/E1 Links with Asynchronous Data Link Signaling	225
Figure 14 -8 T1/E1 Links with no JA or PLL in LIU, Slave or Master Mode, Jitter-Free ST-BUS.....	226
Figure 15 -8 T1/E1 Links with ATM IMA.....	227
Figure 16 -8 T1/E1 Links with Asynchronous ST-BUS.....	228
Figure 17 -DS3 (44Mb/s) Mux Cross Connect with 28 Asynchronous T1 Links.....	229
Figure 18 -DS3 (44Mb/s) Mux Concentrator with 28 Asynchronous T1 Links.....	230
Figure 19 -E3 (34Mb/s) MUX Cross Connect with 16 Asynchronous E1 Links	231
Figure 20 -E3 (34Mb/s) MUX Concentrator to 16 Asynchronous E1 Links	232

Table of Contents (continued)

18.0 AC/DC Electrical Characteristics	233
Figure 21 -Timing Parameter Measurement Voltage Levels	234
Figure 22 -Motorola Microprocessor Timing.....	234
Figure 23 -Intel Microprocessor Timing	235
Figure 24 -ST-BUS 2.048Mb/s Timing	236
Figure 25 -ST-BUS 2.048Mb/s Functional Timing Diagram	236
Figure 26 -ST-BUS 8.192Mb/s Timing	237
Figure 27 -ST-BUS 8.192Mb/s Functional Timing Diagram for DSTi/DSTo.....	237
Figure 28 -ST-BUS 8.192Mb/s Functional Timing Diagram for CSTo/CSTi CAS	238
Figure 29 -S-BUS 8.192Mb/s Functional Timing Diagram for CSTo/CSTi CCS	238
Figure 30 -GCI 2.048 Mb/s Timing Diagram.....	239
Figure 31 -GCI 2.048Mb/s Functional Timing Diagram	239
18.1 AC Electrical Characteristics - T1 Mode Timing.....	240
Figure 32 -T1 IMA Mode Timing Diagram	240
Figure 33 - T1 IMA Functional Timing Diagram.....	241
Figure 34 -T1 Transmit Multiframe Timing	242
Figure 35 -T1 Transmit Multiframe Functional Timing.....	242
Figure 36 -T1 Receive Multiframe Timing with Tx8KEN Set to 0	243
Figure 37 -Receive Multiframe Functional Timing with Tx8KEN Set to 0.....	243
Figure 38 -T1 Receive Multiframe Timing with TX8KEn Set to 1	244
Figure 39 -T1 Receive Multiframe Timing Functional Timing Diagram with TX8KEn Set to 1	244
Figure 40 -Transmit Data Link Pin Timing	245
Figure 41 -T1 Transmit Data Link Functional Timing	245
Figure 42 -T1 Receive DataLink Timing	246
Figure 43 -T1 Receive Data Link Functional Timing	246
Figure 44 -T1 Receive Basic Frame Pulse Pin Timing.....	247
Figure 45 -T1 PCM24 Transmit Timing	247
Figure 46 -T1 PCM24 Transmit Functional Timing.....	248
Figure 47 -T1 PCM24 Receive Timing	249
Figure 48 -T1 PCM24 Receive Functional Timing.....	249
18.1.1 AC Electrical Characteristics - PCM24 and ST-BUS Frame Format	250
Figure 49 -T1 PCM24 Format.....	250
Figure 50 -ST-BUS Format.....	250
18.2 AC Electrical Characteristics - E1 Mode Timing.....	251
Figure 51 -E1 Receive IMA Timing.....	251
Figure 52 -E1 Receive IMA Functional Timing	251
Figure 53 -E1 Transmit Multiframe (CRC-4 or CAS) Timing	252
Figure 54 -E1 Transmit Multiframe (CRC-4 or CAS) Functional Timing.....	252
Figure 55 -E1 Receive Multiframe (CRC-4 or CAS) Timing with Tx8KEN Set to 0	253
Figure 56 -E1 Receive Multiframe (CRC-4 or CAS) Functional Timing with Tx8KEN Set to 0	253
Figure 57 -E1 Receive Multiframe Timing with TX8KEn Set to 1	254
Figure 58 -E1 Receive Multiframe Timing with TX8KEn Set to 1	254
Figure 59 -E1 Transmit Data Link Pin Timing.....	255
Figure 60 -E1 Transmit Data Link Pin Functional Timing	256
Figure 61 -E1 Receive Basic Frame and E4o Timing	257
Figure 62 -E1 Receive Data Link Timing.....	257

Table of Contents (continued)

Figure 63 -E1 Receive Data Link Pin Functional Timing	258
Figure 64 -E1 PCM30 Transmit Timing	259
Figure 65 -E1 PCM30 Transmit Functional Timing	260
Figure 66 -E1 PCM30 Receive Timing	260
Figure 67 -E1 PCM30 Receive Functional Timing	261
18.2.1 AC Electrical Characteristics - PCM30 and ST-BUS Frame Format	262
Figure 68 -DS1 Link Frame Format (E1)	262
Figure 69 -ST-BUS Format.....	262
18.2.2 AC Electrical Characteristics - JTAG Port Timing	263
Figure 70 -JTAG Port Timing.....	263

1.0 Overview

The MT9072 is an eight port (octal) framing device that can be software configured for T1, E1 or J1 operation. Each of the eight framers can be independently timed and controlled. Each framer features one embedded HDLC (High-level Data Link Controller) that can be assigned to the maintenance channel or to any other channel.

1.1 Standards Compliance

In T1 mode, the MT9072 meets or supports the latest recommendations including AT&T PUB43801, TR-62411, ANSI T1.102, T1.403 and T1.408. It also supports Telcordia GR-303-CORE. In T1 ESF mode the CRC-6 calculation and yellow alarm can be configured to meet the requirements of a J1 interface.

In E1 mode, the MT9072 meets or supports the latest ITU-T Recommendations for PCM30 and ISDN primary rate including G.703, G.704, G.706, G.732, G.775, G.796, G.823, G.965 (V5.2) and I.431. It also meets or supports ETSI TBR4, TBR13, ETS 300 233, and ETS 300 347 (V5.2).

1.2 Microprocessor Port

A 16-bit parallel Motorola or Intel non-multiplexed microprocessor interface is used to access the control and status registers.

1.3 Interface to the Physical Layer Device

On the line side the MT9072 framers interface to physical layer devices (typically LIUs) using a Return to Zero (RZ) or Non Return to Zero (NRZ) protocol. The data can be single rail or dual rail with several T1 and E1 line coding options available.

In T1 mode, the receive and transmit paths each include a two-frame slip buffer. The transmit slip buffer features programmable delay and it serves as a rate converter between the ST-BUS and the 1.544Mbit/s T1 line rate.

In E1 mode, the receive path includes a two-frame slip buffer.

1.4 Interface to the System Backplane

On the system side the MT9072 framers can interface to a 2.048Mbit/s or 8.192Mbit/s ST-BUS backplane, or a 2.048 Mbit/s GCI backplane.

There is an IMA (Inverse MUX for ATM) mode for IMA applications, this enables the framer to interface to a 1.544Mbit/s (T1) or 2.048Mbit/s (E1) serial bus with asynchronous transmit and receive timing.

1.5 Framing Modes

The MT9072 framers operate in termination mode or transparent mode. In the receive transparent mode, the received line data is channelled to the DSTo pin with arbitrary frame alignment. In the transmit transparent mode, no framing or signaling is imposed on the data transmitted from the DSTi pin onto the line.

In T1 mode the framers operate in any of the following framing modes: D4, Extended Superframe (ESF) or T1DM.

In E1 mode the framers run three framing algorithms: basic frame alignment, signalling multiframe alignment and CRC-4 multiframe alignment. The Remote Alarm Indication (RAI) bit is automatically controlled by an internal state machine.

1.6 Access to the Maintenance Channel

The T1 ESF Facility Data Link (FDL) bits can be accessed in the following three ways: Through the data link pins TxDL, RxDL, RxDLC and TxDLC or through internal registers for Bit Oriented Messages or through the embedded HDLC.

In E1 mode the Sa bits (bits 4-8 of the non-frame alignment signal) can be accessed in four ways: Through data link pins TxDL, RxDL, RxDLC and TxDLC or through single byte transmit and receive registers or through five byte transmit and receive national bit buffers or through the embedded HDLC.

1.7 Robbed Bit Signaling/Channel Associated Signaling

Robbed bit signaling and channel associated signaling information can be accessed two ways: Via the microport; via the CSTi and CSto pins. Signaling information is frozen upon loss of multiframe alignment.

In T1 mode the MT9072 supports AB and ABCD robbed bit signaling. Robbed bit signaling can be enabled on a channel by channel basis.

In E1 mode the MT9072 supports Channel Associated Signaling (CAS) multiframing.

1.8 Common Channel Signaling

MT9072 supports Common Channel Signaling (CCS) with the embedded HDLCs and with the capability to map external HDLCs to/from the transmit/receive timeslots.

In T1 mode CCS is supported in any one channel by using the embedded HDLC. Alternatively, the CSTi and CSto pins can be used to map an external HDLC channel to/from any one transmit/receive T1 channel.

In E1 mode CCS is supported in any one timeslot by using the embedded HDLC. Alternatively, the CSTi and CSto pins can be used to map three external HDLC channels to/from any of transmit/receive E1 timeslots 15, 16 and 31.

1.9 HDLCs

The MT9072 provides one embedded HDLC per framer with 32 byte deep transmit and receive FIFOs.

In T1 mode the embedded HDLC can be assigned to the FDL or any channel. It can operate at 4kbit/s (Data Link), 56kbit/s or 64kbit/s.

In E1 mode the embedded HDLC can be assigned to timeslot zero Sa bits (bits 4-8 of the non-frame alignment signal), or any other timeslot. It can operate at 4,8,12,16,20 (Data Link) or 64kbit/s.

1.10 Performance Monitoring and Debugging

The MT9072 has a comprehensive suite of performance monitoring and debugging features. These include error counters, loopbacks, deliberate error insertion and a $2^{15}-1$ QRS/PRBS generator/detector.

Interrupts

The MT9072 provides a comprehensive set of maskable interrupts. Interrupt sources consist of synchronization status, alarm status, counter indication and overflow, timer status, slip indication, maintenance functions and receive signaling bit changes.

2.0 PCM24 Interface (T1)

2.1 T1 Interface to the System Backplane

PCM24 (T1) basic frames are 193 bits long and are transmitted at a frame repetition rate of 8000 Hz, which results in an aggregate bit rate of 193 bits x 8000/sec = 1.544 Mbits/sec. Basic frames are divided into 24 channels numbered 1 to 24 and a framing bit; see Figure 4. Each timeslot is 8 bits in length and is transmitted most significant bit first (numbered bit 1). This results in a single channel data rate of 8 bits x 8000/sec. = 64 kbit/s.

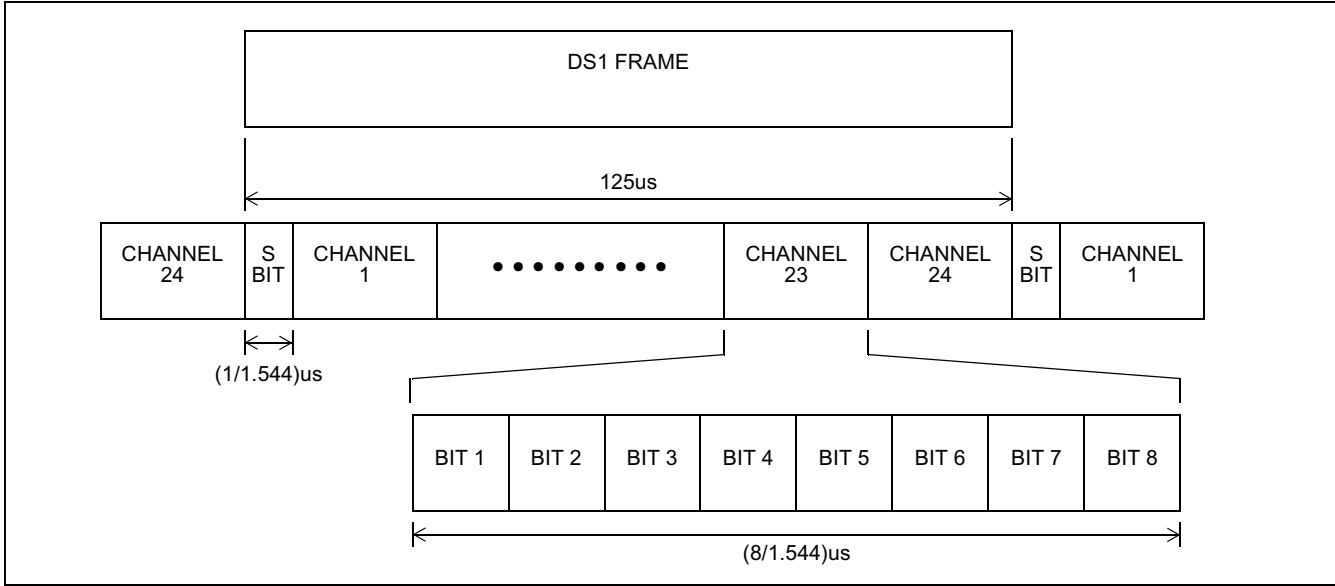

Figure 4 - PCM24 Link Frame Format (T1)

It should be noted that the Zarlink ST-BUS has 32 channels numbered 0 to 31 and the most significant bit of an eight bit channel is numbered bit 7, see Figure 5. Therefore, ST-BUS bit 7 is synonymous with DS0 bit 1; bit 6 with bit 2 and so on. See Zarlink Application note MSAN-126 for more details on the ST-BUS.

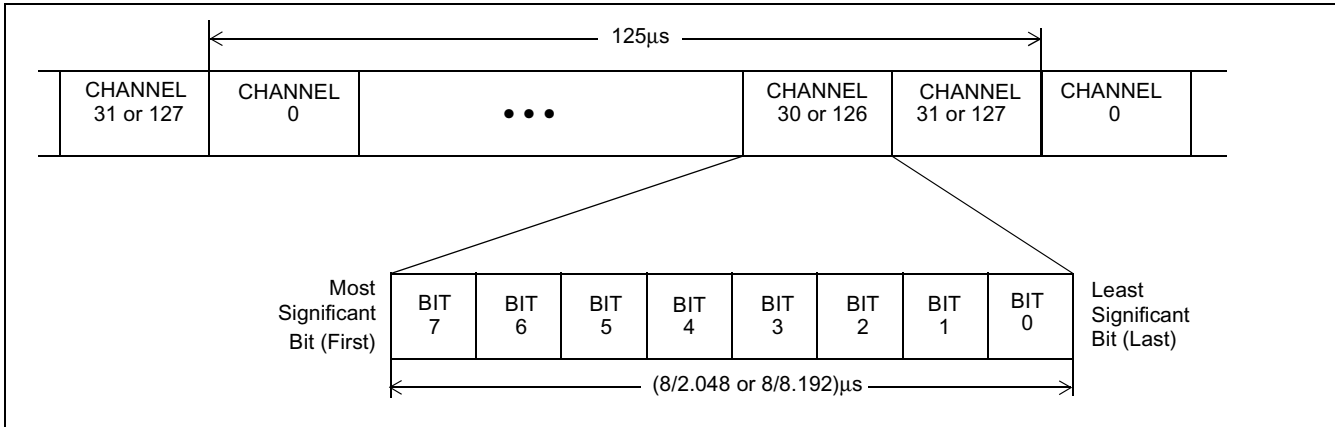

Figure 5 - ST-BUS Format

In the case of mapping ST-BUS to the PCM24 payload, only the first 24 channels and the last channel (31) of an ST-BUS are used (see Table 1). Timeslot 31 S-bit is only used if TXSYNC bit Y00 is set. All unused channels are tristate.

The relationship between DSTi/CSTi and the voice channels in 8.192 Mbit/s mode is shown in Table 2 (F01-F7 refer to the Framers numbers). There are 2 multiplexed streams (DSTi/o0 and CSTi/o0 are used to multiplexed data for Framers 0 to 3 and DSTi/o4 and CSTi/o4 is used for framers 5 to 7).

When the device is in IMA (Inverse Mux for ATM) mode, the mapping is the S-bit followed by 24 PCM channels. This relationship is shown in Table 3. Note that the S-bit location in the Table is indicated by the bit number; which starts from bit 0. Hence the strict definition of ST-BUS channels is not adhered to. As in a T1 interface the data on the DSTi/o is a bit followed by 24 channels.

When signaling information is written to the MT9072 using ST-BUS control links (as opposed to direct writes by the microport to the on-board signaling registers), the CSTi channels corresponding to the selected DSTi channel streams are used to transmit the signaling bits. Since the maximum number of signaling bits associated with any channel is 4 (in the case of ABCD), only half a CSTi (bits 3 to 0) channel is required for sourcing the signaling bits. Bit A is bit 3 from the CSTi stream, Bit B is 2, Bit C is 1, and Bit D is 0. Unused channels and unused bits are tristate.

In T1 transparent mode, the DSTi data is transparently sent to the PCM24 channels. In transparent mode the data on the DSTi streams will appear unaltered on the PCM24 links and data received on the PCM24 link will pass unaltered to the DSTo streams. No signaling insertion or extraction is done in transparent mode. If the TxSYNC control bit (address Y00) is 1 then the transmit S-bit is overwritten by channel 31 bit 0 in the 2.048 Mbit/s ST-BUS mode. In the 8.192 Mbit/s ST-BUS mode the S-bits from channels 124,125,126,127 respectively are used to override the transmit S-bit positions for Framers 0 to 3 or 4 to 7 respectively. If T1 Transparent mode and IMA mode are both selected then the S-bit and channel bits are transparently mapped as shown in Table 3.

PCM24 Channels	1	2	3	4	5	6	7	8	9	10	11	12	13	14	15	16
ST-BUS Channels (DSTi/o and CSTi/o)	0	1	2	3	4	5	6	7	7	9	10	11	12	13	14	15
PCM24 Channels	17	18	19	20	21	22	23	24	-	-	-	-	-	-	-	S-bit
ST-BUS Channels (DSTi/o and CSTi/o)	16	17	18	19	20	21	22	23	24	25	26	27	28	29	30	31
									x	x	x	x	x	x	x	

Table 1 - ST-BUS vs. PCM24 Channel Relationship for 2.048 Mbit/s DST/CST Streams (T1)

PCM24 Channels	1	2	3	4	5	6	7	8	9	10	11	12	13	14	15	16
ST-BUS F0/4	0	4	8	12	16	20	24	28	32	36	40	44	48	52	56	60
Chan(DSTi/o F1/5	1	5	9	13	17	21	25	29	33	37	41	45	49	53	57	61
and CSTi/o) F2/6	2	6	10	14	18	22	26	30	34	38	42	46	50	54	58	62
F3/7	3	7	11	15	19	23	27	31	35	39	43	47	51	55	59	63
PCM24 Channels	17	18	19	20	21	22	23	24	S-bit	-	-	-	-	-	-	-
ST-BUS F0/4	64	68	72	76	80	84	88	92	124							
Chan(DSTi/o F1/5	65	69	73	77	81	85	89	93	125							
and CSTi/o) F2/6	66	70	74	78	82	86	90	94	126							
F3/7	67	71	75	79	83	87	91	95	127							

Table 2 - ST-BUS Channel vs. PCM24 Channel Relationship for 8.192 Mbit/s DST/CST Streams (T1)

PCM24 Channels	S bit	1	2	3	4	5	6	7	8	9	10	11	12	13	14	15
ST-BUS Channels (DSTi/o)	Bit 0	0	1	2	3	4	5	6	7	8	9	10	11	12	13	14
PCM24 Channels	16	17	18	19	20	21	22	23	24							
ST-BUS Channels (DSTi/o)	15	16	17	18	19	20	21	22	23							

Table 3 - ST-BUS vs. PCM24 to Channel Relationship for IMA DST Streams (T1)

2.2 T1 Interface to the Physical Layer Device

Control bits in the Line Interface and Coding word (address Y01) determine the format of the PCM24 transmit and receive signals. Three physical interface formats are provided including RZ dual rail, NRZ dual rail and NRZ single rail.

The detailed timing diagrams are presented in Figures 45 to Figures 48.

RZ Dual Rail - On the Transmit side the pulse width is approximately half the duration of the PCM24 bit cell centered around the falling edge of TXCL. On the receive side RPOS and RNEG are sampled on the falling edge of EXCLi. Note that the CLKE bit in register Y01(selectable for edge sampling) has no effect in RZ mode.

NRZ Dual Rail - With this format, pulses are present for the full bit cell, which allows the set-up and hold times to be easily met. For the receiver the sampling point can be the rising edge or the falling edge of the EXCLi clock, depending on the CLKE bit in Register Y01. The transmitted data can be output either on the rising or falling edge of TXCL selected by the CLKE bit. TXCL is an input in T1 mode and an output in E1 mode.

NRZ Single Rail - This NRZ format is not dual rail, and therefore, only requires a single output line and a single input line (i.e., TPOS and RPOS). The CLKE bit in Register Y01 controls the TXCL clock edge and the EXCLi sampling edge.

2.3 T1 Line Coding

B8ZS (zero code substitution) is selectable globally for both the transmit and receive path (register Y01). Jammed bit 7, GTE, DDS or BELL zero code suppression are also available for the transmitter and receiver(register Y01).

Different schemes for provision of ones density can be selected with bits ZCS2:0 (registers Y01). GTE suppression is achieved by replacing the LSB of zero bytes by a one except for the signaling frame. DDS suppression is replacement of zero byte by 10011000. Bell code suppression is replacement of bit 1(second bit after LSB) of a zero byte. Jammed bit seven selection will replace the LSB of each channel with a '1'.

2.4 T1 Pulse Density

Bit 4 of address Y10 (PDV) toggles if the receive data fails to meet ones density requirements. It will toggle upon detection of 16 consecutive zeros in the line data, or if there are fewer than N ones in a window of $8(N+1)$ bits - where $N = 1$ to 23.

The transmit T1 data is monitored and if the 12.5% density requirement is not met over a maximum 192 bit window a one is inserted in a non-framing bit. The window and PDV criteria is the same as the received PDV.

3.0 PCM30 Interface (E1)

3.1 E1 Interface to the System Backplane

PCM30 (E1) basic frames are 256 bits long and are transmitted at a frame repetition rate of 8000 Hz, which results in an aggregate bit rate of $256 \text{ bits} \times 8000/\text{sec} = 2.048\text{Mbits}/\text{sec}$. The actual bit rate is $2.048\text{Mbit}/\text{s} \pm 50 \text{ ppm}$ encoded in HDB3 (High Density Bipolar 3) format. Basic frames are divided into 32 timeslots numbered 0 to 31, see Figure 6. Each timeslot is 8 bits in length and is transmitted most significant bit first (numbered bit 1). This results in a single timeslot data rate of $8 \text{ bits} \times 8000/\text{sec} = 64 \text{ kbit}/\text{s}$.

It should be noted that the Zarlink ST-BUS also has 32 channels numbered 0 to 31, but the most significant bit of an eight bit channel is numbered bit 7, see Figure 5. Therefore, ST-BUS bit 7 is synonymous with PCM30 bit 1; bit 6 with bit 2: and so on, see Zarlink Application Note MSAN-126 for more details on the ST-BUS.

Tables 4 and 5 show the mapping between the ST-BUS channels and the PCM30 timeslots.

When the device is in IMA (Inverse Mux for ATM) mode the mapping between the ST-BUS Channels and the PCM30 timeslots is according to Table 4.

PCM30 timeslot 0 is reserved for basic frame alignment, CRC-4 multiframe alignment and the communication of maintenance information (facility data link). In most configurations timeslot 16 is reserved for either Channel Associated Signaling (CAS or ABCD bit signaling) or Common Channel Signaling (CCS). For V5.2 applications, timeslots 15, 16 and 31 may be used for CCS. The remaining timeslots are called channels and carry either PCM encoded voice signals or digital data. Channel alignment and bit numbering is consistent with timeslot alignment and bit numbering. However, channels are numbered 1 to 30 and relate to timeslots as per Table 6.

PCM30 Timeslots	0	1	2	3	4	5	6	7	8	9	10	11	12	13	14	15
ST-BUS Channels (DSTi/o and CSTi/o)	0	1	2	3	4	5	6	7	8	9	10	11	12	13	14	15
PCM30 Timeslots	16	17	18	19	20	21	22	23	24	25	26	27	28	29	30	31
ST-BUS Channels (DSTi/o and CSTi/o)	16	17	18	19	20	21	22	23	24	25	26	27	28	29	30	31

Table 4 - ST-BUS Channel vs. PCM30 Timeslot for 2.048 Mbit/s DST/CST Streams (E1)

PCM30 Timeslots	0	1	2	3	4	5	6	7	8	9	10	11	12	13	14	15
ST-BUS F0/4	0	4	8	12	16	20	24	28	32	36	40	44	48	52	56	60
Chan(DSTi/o F1/5	1	5	9	13	17	21	25	29	33	37	41	45	49	53	57	61
and CSTi/o) F2/6	2	6	10	14	18	22	26	30	34	38	42	46	50	54	58	62
F3/7	3	7	11	15	19	23	27	31	35	39	43	47	51	55	59	63
PCM30 Timeslots	16	17	18	19	20	21	22	23	24	25	26	27	28	29	30	31
ST-BUS F0/4	64	68	72	76	80	84	88	92	96	100	104	108	112	116	120	124
Chan(DSTi/o F1/5	65	69	73	77	81	85	89	93	97	101	105	109	113	117	121	125
and CSTi/o) F2/6	66	70	74	78	82	86	90	94	98	102	106	110	114	118	122	126
F3/7	67	71	75	79	83	87	91	95	99	103	107	111	115	119	123	127

Table 5 - ST-BUS Channel vs. PCM30 Timeslot Relationship for 8.192 Mbit/s DST/CST Streams (E1)

PCM30 Timeslot	0	1 2 3...15	16	17 18 19...31
PCM30 Voice/Data Channels	x	1 2 3...15	x	16 17 18...30

Table 6 - PCM30 Timeslot to PCM30 Channel Relationship (E1)

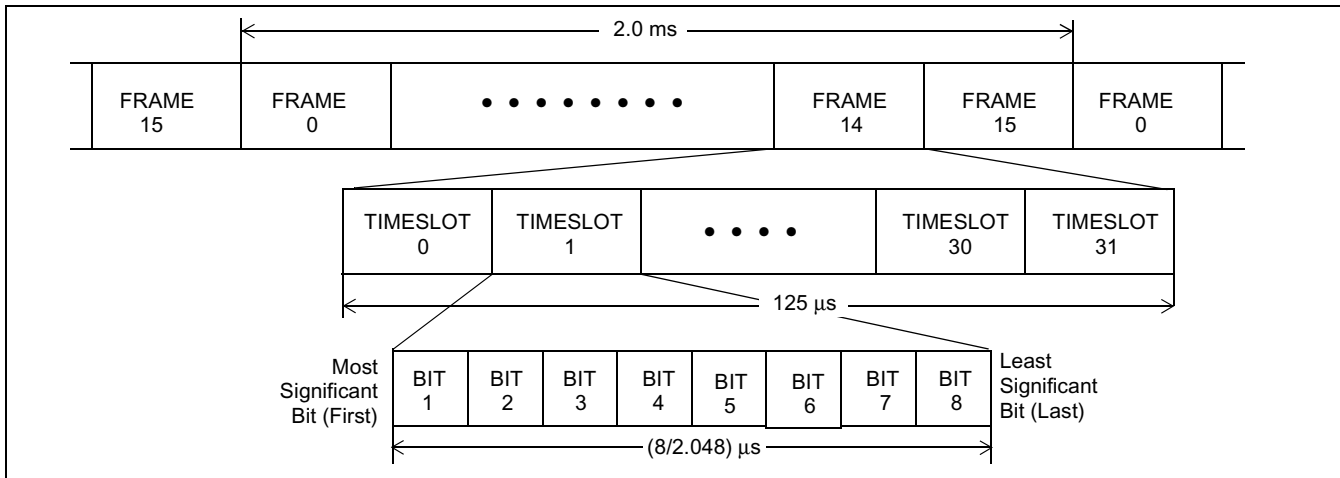

Figure 6 - PCM30 Format (E1)

3.2 E1 Interface to the Physical Layer Device

Register control bits COD1-0 (address Y02) determine the format of the PCM30 transmit and receive signals. Three interface formats are provided including RZ dual rail, NRZ dual rail and NRZ single rail.

RZ Dual Rail - On the Transmit side the pulse width is approximately half the duration of the PCM30 bit cell centered around the falling edge of TXCL. On the receive side RPOS and RNEG are sampled on the falling edge of EXCLi. Note that the T2OP bit in Register Y02(selectable for edge sampling) has no effect in RZ mode.

NRZ Dual Rail - With this format, pulses are present for the full bit cell, which allows the set-up and hold times to be easily met. For the receiver the sampling point can be the rising edge or the falling edge of the EXCLi clock dependent on the CLKE bit in Register Y01. The transmitted data can be output either on the rising or falling edge of TXCL selected by the T2OP bit. TXCL is an input in T1 mode and output in E1 mode.

NRZ Single Rail - This NRZ format is not dual rail, and therefore, only requires a single output line and a single input line (i.e., TPOS and RPOS). The T2OP bit controls the TXCL clock edge and CLKE bit controls the RPOS/RNEG sampling.

HDB3 - Register Control bit $\overline{\text{THDB3}}$ (address Y02) determines the PCM30 encoding in the transmit direction. The encoding can either be HDB3 or alternate mark inversion (AMI). The $\overline{\text{RHDB3}}$ (address Y02) bit selects the receive HDB3 decoding.

4.0 Framing

4.1 T1 Framing

DS1 trunks contain 24 bytes of serial voice/data channels bundled with an overhead bit - the S-bit. The S-bit contains a fixed repeating pattern used to enable DS1 receivers to delineate frame boundaries. S-bits are inserted once per frame at the beginning of the transmit frame boundary. The DS1 frames are further grouped in bundles of frames, generally 12 (for D4 applications) or 24 frames deep (for ESF - extended superframe applications). The registers for controlling and observing the framing algorithms are presented in the Table 7.

Register Address	Register	Description
Y00	Framing Mode Select	This register is used for selecting the different framing modes from ESF to D4 or T1DM. The register is also used for selecting reframe criteria.
Y10	Synchronization and Alarm Status Word.	This register provides the real time status of the receive framing algorithm as to basic frame synchronization and multiframe synchronization.
Y16	MFOOF Counter	This status register increments every 1.5 msec for D4 mode or every 3 msec for ESF mode when the basic frame synchronization is lost.
Y17	Framing Bit Error Counter	This counter counts the Ft errors in ESF mode and Ft+Fs error in D4 and T1DM.
Y19	CRC-6 Error Counter	This counter counts the CRC-6 errors by comparing the calculated CRC-6 with the CRC-6 bits in the ESF frame.
Y1A	Out of Frame Counter and Change of Frame Counter	The out of frame counter is incremented with every loss of receive frame synchronization. The change of frame counter is incremented with every shift in the frame alignment position.
Y24	Receive Sync and Alarm Latch	This register contains latched bits for events related to framing such as framing bit errors.
Y28	Framing Bit Error Count Latch	This counter is a latched version of Y17, the value of this counter is updated every 1 sec.
Y2A	CRC-6 Error Counter Latch	This counter is a latched version of Y19, the value of this counter is updated ever 1 sec.
Y2B	Out of Frame Counter Latch and Change of Frame Counter Latch	This counter is a latched version of Y19, the value of this counter is updated ever 1 sec.
Y2C	MFOOF Counter Latch	This counter is a latched version of Y16, the value of this counter is updated ever 1 sec.
Y34	Receive Sync Interrupt Status Register	This register captures interrupt events related to the receiver framer such as Framing Bit error. Interrupts can be generated by setting appropriate masks.
Y44	Receive Sync Interrupt Status Register Mask	This mask corresponds to the Y34 status register. Writing a "0" unmask an interrupt.

Table 7 - Registers Related to Framing Mode for the MT9072 (T1)

4.1.1 T1 D4 Framing

For D4 links the S-bit position contains an alternating 101010... pattern inserted into every second S-bit. These bits are intended for determination of frame boundaries, and they are referred to as Ft bits. A separate fixed pattern, repeating every superframe, is interleaved with the Ft bits. This fixed pattern (001110) is used to delineate the 12 frame superframe. These bits are referred to as the Fs bits. In D4 frames # 6 and #12, the LSB of each channel byte may be replaced with A bit (frame #6) and B bit (frame #12) signaling information. See Table 8.

Frame #	Ft	Fs	Signaling
1	1		
2		0	
3	0		
4		0	
5	1		
6		1	A
7	0		
8		1	
9	1		
10		1	
11	0		
12		0	B

Table 8 - D4 Superframe Structure (T1)

4.1.2 T1 ESF Framing

For ESF links the 6 bit framing pattern 001011, inserted into every 4th S-bit position, is used to delineate both frame and superframe boundaries. Frames #6, 12, 18 and 24 may contain the A, B, C and D signaling bits, respectively. A 4 kHz data link is embedded in the S-bit position, interleaved between the framing pattern sequence (FPS) and the transmit CRC-6 remainder (from the calculation done on the previous superframe). See Table 9.

Frame #	FPS	FDL	CRC	Signaling
1		X		
2			CB1	
3		X		
4	0			
5		X		
6			CB2	A
7		X		
8	0			
9		X		
10			CB3	
11		X		
12	1			B
13		X		
14			CB4	

Table 9 - ESF Superframe Structure (T1)

Frame #	FPS	FDL	CRC	Signaling
15		X		
16	0			
17		X		
18			CB5	C
19		X		
20	1			
21		X		
22			CB6	
23		X		
24	1			D

Table 9 - ESF Superframe Structure (T1)

4.1.3 T1 T1DM Framing

The Ft and Fs bits are identical to the D4 format, channel 24 of each frame has a synchronization byte consisting of 10111YR0.

Y is used to indicate a yellow alarm and is active low. R bit is reserved by AT&T as an 8 Kb/s communication channel.

The synchronization is first declared if the Ft bit is in sync and subsequently 6 consecutive T1DM synchronization bytes are received. The synchronization error criteria for the receiver will be the same as D4.(i.e 2 out of 4,5 or 6). Although an error is detected if any of 5 synchronization bits or the Ft/Fs bits are incorrect.The OOF error selection criteria of 2 errors out of 4, 5, 6 bits is also applicable to the T1DM sync byte format; the error criteria applies to the synchronization byte and the framing bit. The received sync byte can be monitored by the status register(Y10). The Y bit can be sent by writing to control register(address Y02). The TIDMR bit can only be input from the Transmit Data Link Pin. The registers and bits used for T1DM are indicated in the register bit functions.

4.1.4 T1 G.802 Mode

G.802 mode allows interworking between an E1 and T1 system. The line is operating in T1 mode and the backplane consists of E1 data. The mapping for the backplane channels to the PCM24 side is as shown Table 10. The 193 bits from the E1 backplane stream are mapped to the 193 bits of the PCM24 side. The channel 0 and channel 16 on the backplane side are the G.704 Timeslot 0 and 16 channels and are not mapped.

DSTi/DSTo Channel#, Bit#	PCM24 bits	Function
0	Not mapped	Timeslot 0
1,bit 7(MSB)	S-bit	S-bit
1(bit 6 to 0)-15	119 bits	
16	Not mapped	Timeslot 16
17-25	120 to 192	
channel 16, bit 1	193 bit	last bit

Table 10 - G.802 ST-BUS to PCM24 Mapping (T1)

4.2 E1 Framing

The following Table shows the registers related to the E1 framing algorithm.

Register Address	Register	Description
Y00	Alarm and Framing Control Register	This is the main register for selection of the framing mode. The specific bits for control of the framer are $\overline{\text{CSYN}}$, $\overline{\text{AUTY}}$, $\overline{\text{CRCM}}$, $\overline{\text{REFRM}}$, $\overline{\text{MFRF}}$ and $\overline{\text{AUTC}}$
Y10	Synchronization and Alarm Status Word.	This register provides the real time status of receive basic frame synchronization and receive multiframe synchronization. All bits in this status register are relevant to framing except the slip bits.
Y11	CRC-4 Timers and CRC-4 Local Status	All bits except the 2 sec timer are related to the reception of the CRC-4 pattern in timeslot 0.
Y12	Alarm and Multiframe signaling Status	This register reports alarms such as AIS, loss of signal and Timeslot 16 and 0 remote alarms. The bits of relevance for framing are $\overline{\text{KLVE}}$, $\overline{\text{LOSS}}$, $\overline{\text{AIS16}}$, $\overline{\text{AIS}}$, $\overline{\text{RAI}}$, $\overline{\text{RMA1}}$ to 4, Y bit.
Y13	NFAS and FAS Status Register	This register shows the FAS and NFAS status such as $\overline{\text{RFA}}$ 2 to 8 and $\overline{\text{RNFA}}$.
Y16	Loss of basic frame synchronization counter	This counter increments by one every 125 usec when the $\overline{\text{BSYNC}}$ status is set to 1.
Y19	CRC-4 Error Counter	This error counter is incremented for each calculated CRC-4 submultiframe error. The $\overline{\text{CRCS1}}$ and $\overline{\text{CRCS2}}$ (Y11 bit 1 and 2) events increment this counter.
Y1A	FAS Bit Counter and FAS Error Counter.	This register reflects the FAS bit errors and a combined FAS pattern error.
Y24	Sync, CRC-4, MAS Latched Status Register	This register represents the latched version of framing status bits such as $\overline{\text{BSYNC}}$. These bits are set by changes in the associated real time bits.
Y27	Performance Persistent Latched Status Register	This register <u>latches</u> the detection of loss($\overline{\text{LOSSP}}$) and basic frame sync($\overline{\text{BSYNCP}}$).
Y2A	CRC-4 Error Counter Latch.	This a a sampled version of Y19 latched every one sec.
Y34	Sync, CRC-4 Remote, Alarm, MAS and Phase Status Register	These are the interrupt status bits for $\overline{\text{BSYNC}}$, Receive Multiframe Alignment Interrupt etc.
Y35	Counter Indication and Counter Overflow Interrupt status	This register represents the interrupt status bits for counter overflows, counter indications etc.
Y44	Sync Interrupt Mask Register	This is the mask register for the events in register Y34.
Y45	Counter Indication and Counter Overflow Interrupt Mask Register	This is the mask register for the events in register Y35

Table 11 - Registers Related to Framing for MT9072 (E1)

4.2.1 E1 Basic Framing (Timeslot 0)

Timeslot 0 of every 125us frame is reserved for basic frame alignment and contains a Frame Alignment Signal (FAS) or a Non-Frame Alignment Signal (NFAS). FAS and NFAS occur in consecutive basic frames as shown in Table 12.

Bit one of the FAS can be either a CRC-4 remainder bit or an international usage bit.

Bit one of the NFAS can be either a CRC-4 multiframe alignment signal, an E-bit or an international usage bit. Refer to national standards bodies for specific requirements.

Bit two of the FAS and NFAS is used to distinguish between FAS (bit two = 0) and NFAS (bit two = 1) frames.

Bits two to eight of the FAS are used for basic frame alignment. Basic frame alignment is initiated by a search for the bit sequence 0011011 which appears in the last seven bit positions of the FAS, see the Frame Algorithm section.

Bit three of the NFAS (designated as “A”), the Remote Alarm Indication (RAI), is used to indicate the near end basic frame synchronization status to the far end of a link. Under normal operation, the A (RAI) bit should be set to 0, while in alarm condition, it is set to 1.

Bits four to eight of the NFAS (i.e., Sa4-8) are additional spare bits which may be used as follows:

- Sa4-8 may be used in specific point-to-point applications (e.g. transcoder equipments conforming to G.761).
- Sa4 may be used as a message-based data link for operations, maintenance and performance monitoring.
- Sa5-Sa8 are for national usage but are also available from the Data link interface(TxDL,RxDL).
- Note that for simplicity all Sa bits including Sa4 are collectively called national bits throughout this document. See the Data Link section for accessing the national bits.

4.2.2 E1 CRC-4 Multiframing (Timeslot 0)

The primary purpose for CRC-4 multiframing is to provide a verification of the current basic frame alignment, although it can also be used for other functions such as bit error rate estimation. The CRC-4 multiframe consists of 16 basic frames numbered 0 to 15, and has a repetition rate of 16 frames X 125 microseconds/frame = 2 msec.

CRC-4 multiframe alignment is based on the 001011 bit sequence, which appears in bit position one of the first six NFASs of a CRC-4 multiframe.

The CRC-4 multiframe is divided into two submultiframes, numbered 1 and 2, which are each eight basic frames or 2048 bits in length.

CRC-4	CRC-4 Frame/Type	PCM30 Channel Zero							
		1	2	3	4	5	6	7	8
Sub Multi Frame 1	0/FAS	C ₁	0	0	1	1	0	1	1
	1/NFAS	0	1	A	S _{a4}	S _{a5}	S _{a6}	S _{a7}	S _{a8}
	2/FAS	C ₂	0	0	1	1	0	1	1
	3/NFAS	0	1	A	S _{a4}	S _{a5}	S _{a6}	S _{a7}	S _{a8}
	4/FAS	C ₃	0	0	1	1	0	1	1
	5/NFAS	1	1	A	S _{a4}	S _{a5}	S _{a6}	S _{a7}	S _{a8}
	6/FAS	C ₄	0	0	1	1	0	1	1
	7/NFAS	0	1	A	S _{a4}	S _{a5}	S _{a6}	S _{a7}	S _{a8}
Sub Multi Frame 2	8/FAS	C ₁	0	0	1	1	0	1	1
	9/NFAS	1	1	A	S _{a4}	S _{a5}	S _{a6}	S _{a7}	S _{a8}
	10/FAS	C ₂	0	0	1	1	0	1	1
	11/NFAS	1	1	A	S _{a4}	S _{a5}	S _{a6}	S _{a7}	S _{a8}
	12/FAS	C ₃	0	0	1	1	0	1	1
	13/NFAS	E ₁	1	A	S _{a4}	S _{a5}	S _{a6}	S _{a7}	S _{a8}
	14/FAS	C ₄	0	0	1	1	0	1	1
	15/NFAS	E ₂	1	A	S _{a4}	S _{a5}	S _{a6}	S _{a7}	S _{a8}

Table 12 - CRC-4 FAS and NFAS Structure (E1)

 indicates position of CRC-4 multiframe alignment signal.

The CRC-4 frame alignment verification functions as follows. Initially, the CRC-4 operation must be activated and CRC-4 multiframe alignment must be achieved at both ends of the link. At the local end of a link, all the bits of every transmit submultiframe are passed through a CRC-4 polynomial (multiplied by X^4 then divided by $X^4 + X + 1$), which generates a four bit remainder. This remainder is inserted in bit position one of the four FASs of the following submultiframe before it is transmitted (see Table 12).

The submultiframe is then transmitted and, at the far end, the same process occurs. That is, a CRC-4 remainder is generated for each received submultiframe. These bits are compared with the bits received in position one of the four FASs of the next received submultiframe. This process takes place in both directions of transmission.

When more than 914 CRC-4 errors (out of a possible 1000) are counted in a one second interval, the framing algorithm will force a search for a new basic frame alignment if automatic CRC-4 interworking is not invoked.

The result of the comparison of the received CRC-4 remainder with the locally generated remainder will be transported to the far end by the E-bits. Therefore, if $E_1 = 0$, a CRC-4 error was discovered in a submultiframe 1 received at the far end; and if $E_2 = 0$, a CRC-4 error was discovered in a submultiframe 2 received at the far end. No submultiframe sequence numbers or re-transmission capabilities are supported with layer 1 PCM30 protocol. See ITU-T G.704 and G.706 for more details on the operation of CRC-4 and E-bits.

4.2.2.1 E1 Automatic CRC-4 Interworking

When control bit $\overline{\text{AUTC}}$ (register address Y00) is set to zero, the MT9072 framing algorithm supports automatic interworking of interfaces with and without CRC-4 processing capabilities. That is, if an interface with CRC-4 capability, achieves valid basic frame alignment, but does not achieve CRC-4 multiframe alignment by the end of a predefined period, the distant end is considered to be a non-CRC-4 interface. When the distant end is a non-CRC-4 interface, the near end automatically suspends receive CRC-4 functions, continues to transmit CRC-4 data to the distant end with its E-bits set to zero, and provides a status indication. Naturally, if the distant end initially achieves CRC-4 synchronization, CRC-4 processing will be carried out by both ends.

When control bit $\overline{\text{AUTC}}$ is one, Automatic CRC-4 Interworking is deactivated. In this case, if the Automatic Remote Alarm Indication (RAI) Operation ($\overline{\text{ARAI}}$) control bit (register address Y00) is low, and if CRC-4 multiframe alignment is not found in 400 msec, then the transmit Remote Alarm Indication (RAI) (bit 3 (A) of the transmit NFAS) will be continuously high until CRC-4 multiframe alignment is achieved.

The TE control bit (register address Y00) for transmit E bits will have the same function in both states of $\overline{\text{AUTC}}$. That is, when CRC-4 synchronization is not achieved the state of the transmit E-bits will be the same as the state of the TE control bit. When CRC-4 synchronization is achieved the transmit E-bits will function as per ITU-T G.704 as described in the previous section. Table 13 outlines the operation of the $\overline{\text{AUTC}}$, $\overline{\text{ARAI}}$ and TALM control bits of the MT9072.

$\overline{\text{AUTC}}$	$\overline{\text{ARAI}}$	TALM	Description
0	0	X	Automatic CRC-interworking is activated. If no valid CRC MFAS is being received, transmit RAI will flicker high with every reframe (8msec.), this cycle will continue for 400 msec., then transmit RAI will be low continuously. The device will stop searching for CRC MFAS, continue to transmit CRC-4 remainders, stop CRC-4 processing, indicate CRC-to-non-CRC operation and transmit E-bits to be the same state as the TE control bit (control register address Y00).
0	1	0	Automatic CRC-interworking is activated. Transmit RAI is low continuously.
0	1	1	Automatic CRC-interworking is activated. Transmit RAI is high continuously.
1	0	X	Automatic RAI is activated. Automatic CRC-interworking is de-activated. If no valid CRC MFAS is being received, transmit RAI flickers high with every reframe (8 msec.), this cycle continues for 400 msec, then transmit RAI becomes high continuously. The device continues to search for <u>CRC MFAS</u> and transmit E-bits are the same state as the TE control bit. When $\overline{\text{CSYN}} = 0$, the CRC MFAS search is terminated and the transmit RAI goes low.
1	1	0	Automatic RAI is activated. Automatic CRC-interworking is de-activated. Transmit RAI is low continuously.
1	1	1	Automatic RAI is activated. Automatic CRC-interworking is de-activated. Transmit RAI is high continuously.

Table 13 - Operation of $\overline{\text{AUTC}}$, $\overline{\text{ARAI}}$ and TALM Control Bits (E1)

4.2.3 E1 Channel Associated Signaling (CAS) Multiframe (Timeslot 16)

Refer to the section on Channel Associated Signaling (CAS) Operation.

4.2.4 E1 Framing Algorithm

The MT9072 contains three distinct framing algorithms: basic frame alignment, signaling multiframe alignment and CRC-4 multiframe alignment. Figure 7 is a state diagram that illustrates these algorithms and how they interact.

After power-up, the basic frame alignment framer will search for a frame alignment signal (FAS) in the PCM30 receive bit stream. Once the FAS is detected, the corresponding bit 2 of the non-frame alignment signal

(NFAS) is checked. If bit 2 of the NFAS is zero a new search for basic frame alignment is initiated. If bit 2 of the NFAS is one and the next FAS is correct, the algorithm declares that basic frame synchronization has been found (status register address Y10 bit BSYNC is reset to zero).

Once basic frame alignment is acquired the signaling and CRC-4 multiframe searches will be initiated. The signaling multiframe algorithm will align to the first multiframe alignment signal pattern (MFAS = 0000) it receives in the most significant nibble of channel 16 (status register address Y10 bit MSYNC is zero). Signaling multiframe alignment will be lost when two consecutive multiframes are received in error.

The CRC-4 multiframe alignment signal is a 001011 bit sequence that appears in PCM30 bit position one of the NFAS in frames 1, 3, 5, 7, 9 and 11 (see Table 12). In order to achieved CRC-4 synchronization two consecutive CRC-4 multiframe alignment signals must be received without error (status register address Y10 bit CSYNC is zero).

The MT9072 framing algorithm supports automatic interworking of interfaces with and without CRC-4 processing capabilities. That is, if an interface with CRC-4 capability, achieves valid basic frame alignment, but does not achieve CRC-4 multiframe alignment by the end of a predefined period, the distant end is considered to be a non-CRC-4 interface. When the distant end is a non-CRC-4 interface, the near end automatically suspends receive CRC-4 functions, continues to transmit CRC-4 data to the distant end with its E-bits set to zero, and provides a status indication. Naturally, if the distant end initially achieves CRC-4 synchronization, CRC-4 processing will be carried out by both ends. This feature is selected when control bit AUTC (control register address Y00) is set to zero.

4.2.4.1 Notes for Synchronization State Diagram (Figure 7)

- 1) The basic frame alignment, signaling multiframe alignment, and CRC-4 multiframe alignment functions operate in parallel and are independent.
- 2) The receive channel associated signaling bits and signaling multiframe alignment bit will be frozen when multiframe alignment is lost.
- 3) Manual re-framing of the receive basic frame alignment and signaling multiframe alignment functions can be performed at any time.
- 4) The transmit RAI bit will be one until basic frame alignment is established, then it will be zero.
- 5) E-bits can be optionally set to zero until the equipment interworking relationship is established. When this has been determined one of the following will take place:
 - a) CRC-to-non-CRC operation - E-bits = 0,
 - b) CRC-to-CRC operation - E-bits as per G.704 and I.431.
- 6) All manual re-frames and new basic frame alignment searches start after the current frame alignment signal position.
- 7) After basic frame alignment has been achieved, loss of frame alignment will occur any time three consecutive incorrect basic frame alignment signals are received. Loss of basic frame alignment will reset the complete framing algorithm.
- 8) When CRC-4 multiframe alignment has been achieved, the primary basic frame alignment and resulting multiframe alignment will be adjusted to the basic frame alignment determined during CRC-4 synchronization. Therefore, the primary basic frame alignment will not be updated during the CRC-4 multiframe alignment search, but will be updated when the CRC-4 multiframe alignment search is complete.

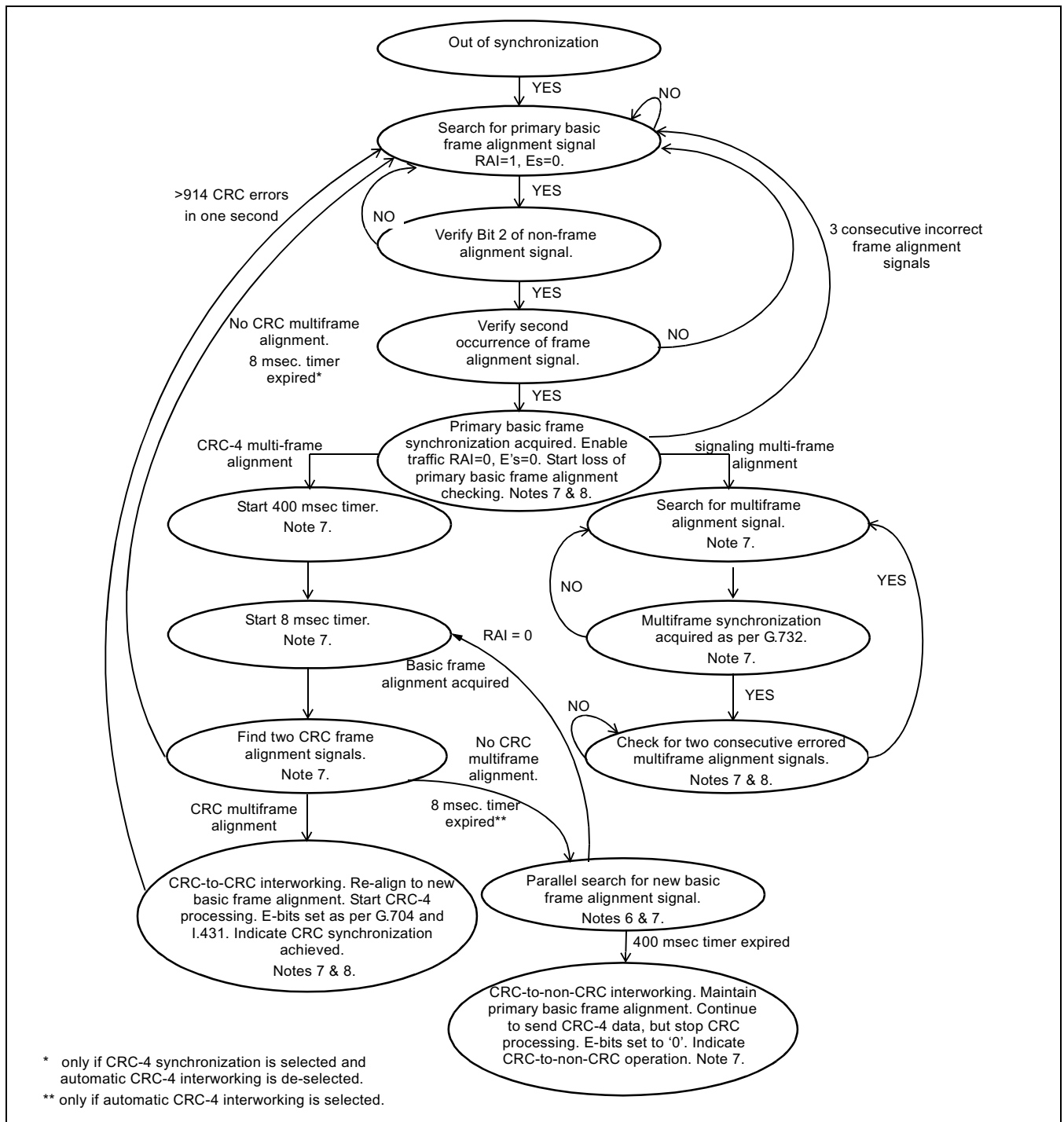

Figure 7 - Synchronization State Diagram (E1)

5.0 Elastic Buffer

The MT9072 has a two frame receive elastic (or slip) buffer, which absorbs wander and low frequency jitter in multi-trunk applications. If desired, the elastic buffer can be bypassed by using the Data Link RxDL pin output (see the following section). The received data (RPOS and RNEG) is clocked into the elastic buffer with the extracted (EXCLi pin) clock and is clocked out of the elastic buffer with the system (CKi pin) clock. The EXCLi clock is generated from the receive data, and is therefore phase-locked with that data. In normal operation, the EXCLi clock will be phase-locked to the CKi clock by an external phase locked loop (PLL). Therefore, in a single trunk system, the receive data is in phase with the EXCLi clock, the CKi clock is phase-locked to the EXCLi clock, and the read and write positions of the elastic buffer will remain fixed with respect to each other.

In a multi-trunk slave or loop-timed system (i.e., PABX application) a single trunk will be chosen as a network synchronizer, which will function as described in the previous paragraph. The remaining trunks will use the system timing derived from the synchronizer to clock data out of their slip buffers. Even though the signals from the network are synchronous to each other, due to multiplexing, transmission impairments and route diversity, these signals may jitter or wander with respect to the synchronizing trunk signal. Therefore, the EXCLi clocks of non-synchronizer trunks may wander with respect to the EXCLi clock of the synchronizer and the system bus.

Network standards state that, within limits, trunk interfaces must be able to receive error-free data in the presence of jitter and wander (refer to network requirements for jitter and wander tolerance). The MT9072 will allow a maximum of 26 channels (208 UI, unit intervals) of wander and low frequency jitter before a frame slip will occur.

The minimum delay through the receive slip buffer is approximately two channels and the maximum delay is approximately 60 channels (see Figure 8).

When the CKi and the EXCLi clocks are not phase-locked, the rate at which data is being written into the slip buffer from the line side may differ from the rate at which it is being read out onto the ST-BUS. If this situation persists, the delay limits stated in the previous paragraph will be violated and the slip buffer will perform a controlled frame slip. That is, the buffer pointers will be automatically adjusted so that a full frame is either repeated or lost. All frame slips occur on frame boundaries.

Two status bits, RSLP and RSLPD (register address Y10 for E1 and Y13 for T1), give indication of a slip occurrence and direction. RSLP changes state in the event of a slip. If RSLPD=0, the slip buffer has overflowed and a frame was lost; if RSLPD=1, a underflow condition occurred and a frame was repeated. A maskable interrupt status bit RSLIPI (register address Y34 for E1 and Y36 for T1) is also provided.

Figure 8 illustrates the relationship between the read and write pointers of the receive slip buffer. Measuring clockwise from the write pointer, if the read pointer comes within two channels of the write pointer a frame slip will occur, which will put the read pointer 34 channels from the write pointer. Conversely, if the read pointer moves more than 60 channels from the write pointer, a slip will occur, which will put the read pointer 28 channels from the write pointer. This provides a worst case hysteresis of 13 channels peak (26 channels peak-to-peak) or a wander tolerance of 208 UI. The registers relevant to controlling and observing the elastic buffer in T1 mode are shown in Table 14. The registers related to elastic buffer for E1 are shown in Table 15.

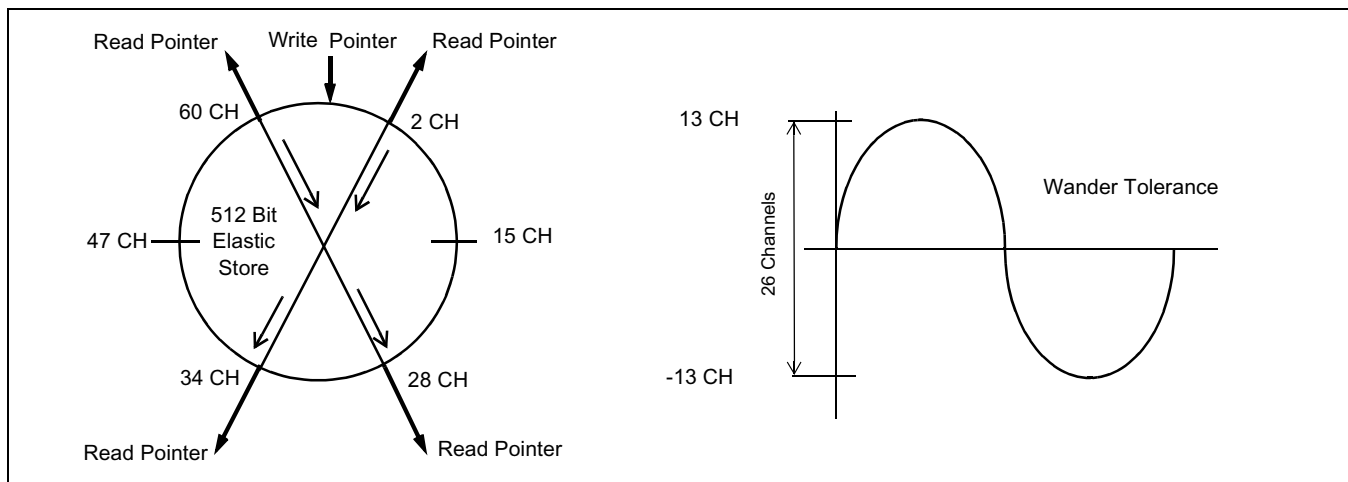

Figure 8 - Read and Write Pointers in the Slip Buffers

In T1 mode, the transmit and receive elastic buffers also serve the purpose of rate conversion between the 1.544 Mbit/s line rate and the 2.048 Mbit/s backplane rate. Consequently, in T1 mode the elastic buffers cannot be bypassed, except for the special case of T1 IMA mode.

Register Address	Register	Description
Y00	Framing Mode Select	If IMA mode is selected the transmit and receive elastic buffers are bypassed.
Y13	Receive Slip Buffer Status Word	This register provides status bits for receive slip and its direction word that indicates the phase difference between the ST-BUS and the PCM24
Y14	Transmit Slip Buffer Status Word	This register provides status bit for transmit slip and its direction word that indicates the phase difference between the ST-BUS and the PCM24.
Y26	Elastic Store and Excessive Zero Status Latch	This register indicates the latched version of the slip indicator bits from registers Y13 and Y14.
Y36	Elastic Store and Excessive Zero Interrupt Status	Interrupt status word for the slip indicators.
Y46	Elastic Store and Excessive Zero Interrupt Mask	Interrupt mask bits for the slip indicators.
YF7	Transmit Set Delay Bits	This register sets a one time delay through the transmit slip buffer.

Table 14 - Registers Related to the Elastic Buffer (T1)

Register Address	Register	Description
Y00	Framing Mode Select	If IMA mode is selected the receive elastic buffers are bypassed.
Y03	DL,CCS,CAS and Other Control Register	ELAS bit is used to bypass the elastic store, that data at DSTo is the received. PCM30 data after the HDB3 coding.
Y10	Sync and CRC-4 Remote status	RSLP and RSLPD show the slip and the direction of the slip.
Y14	Phase Status Indicator	This word reflects the delay through the receive elastic store from the line to the ST-BUS side.
Y34	Sync,CRC-4 Remote, Alarm, MAS and Phase Status Word	RSLIPI in this register reflects the interrupt due to a slip.
Y44	Sync,CRC-4 Remote, Alarm, MAS and Phase Status Word Interrupt Mask	Interrupt mask bits for the slip indicator.

Table 15 - Registers Related to Elastic Store (E1)

5.1 Transmit Elastic Buffer

In T1 mode, the MT9072 contains a transmit elastic buffer in addition to the receive elastic buffer. Data is clocked into the transmit elastic buffer by the 2.048 Mbit/s or 8.192 Mbit/s ST-BUS clock (which is subsequently divided to a 2.048MHz clock). The data is clocked out of the transmit elastic buffer by the 1.544MHz clock input to the TXCL pin.

The delay through the transmit elastic buffer will vary in accordance with the position of the channel in the frame. For example, PCM24 channel 1 sits in the elastic buffer for approximately 1 usec, and PCM24 channel 24 sits in the elastic buffer for approximately 32 usec. The relative phase delay between the system ST-BUS frame boundary and the transmit elastic frame read boundary is measured every frame and reported in the Transmit Slip Buffer Status Word (Y14). In addition, the relative delay between these frame boundaries may be

programmed by writing to Tx Set Delay Bits (register address YF7). Every write to the TX Set Delay Bits resets the Transmit Slip Buffer MSB bit TxSBMSB (register address Y14). After a write, the delay through the slip buffer is less than 1 frame in duration. Each write operation will result in a disturbance of the transmit PCM24 frame boundary, causing the far end to go out of sync.

The transmit elastic buffer is capable of performing controlled slips in a manner similar to the receive elastic buffer. Slips on the transmit side are independent of slips on the receive side. The two status bits. TSLIP and TSLPD (register address Y14), give indication of a slip occurrence and direction. TSLP changes state in the event of a slip. If TSLPD=0, the slip buffer has overflowed and a frame was lost; if TSLPD=1, an underflow condition occurred and a frame was repeated. A maskable interrupt status bit TXSLIPI (register address Y36) is also provided. Under normal operation no slips should occur in the transmit path. Slips will only occur if the input CKi clock has excess wander relative to the input TXCL clock, or if the TX Set Delay Bits (register address YF7) register is initialized too close to the slip pointers after system initialization.

6.0 Data Link

6.1 T1 Data Link

The ESF protocol allows for carrier messages to be embedded in the S-bit position. The MT9072 provides 3 separate means of controlling the Data Link.

- Transmit and receive Data Link pins TxDL, TxDLC, RxDL and RxDLC.
- Bit - Oriented Messages may be transmit and received via dedicated transmit and receive registers(Y07,Y08,Y12). This is only applicable in the ESF mode.
- The ESF Data Link (DL) can be connected to an internal HDLC, operating at a bit rate of 4 kbits/sec. The HDLC can be activated by setting the control bit 1(HDLCEn) of the HDLC & Data Link Control Word (Y06).

In the D4 mode the Fs bits can be inserted/extracted from the Data Link pins by setting the EDLEN bit in Y06. The registers related to the Data Link are shown in Table 16.

Register Address	Register	Description
Y06	HDLC and Data Link Control Register	This register determines the source of the Data Link which can be the HDLC, Bit Oriented messages or the external Data Link. This register also controls the type of clocks provided to the external Data Link interface.
Y07	Transmit bit Oriented Message	This register holds the message that will be sent in ESF FDL if the BOMEN bit in Y06 is set.
Y08	Receive bit Oriented Message Match	This register is the match register for received bit oriented message
Y12	Receive bit Oriented Message	This register holds the value of the receive bit oriented message
Y25	Receive Line Status and Timer Latch	This register contains bit oriented message and bit oriented message match latch bits.
Y35	Receive Line and Timer Interrupt Status	This register contains bit oriented message and bit oriented message match interrupt status bits.
Y45	Receive Line and Timer Interrupt Mask	These are the mask bits for Y35.

Table 16 - Registers Related to the Data Link and Bit Oriented Messages (T1)

6.1.1 T1 Data Link (DL) Pin Access

When EDLEN(Y06) is set to "1" the data link (DL) bits can be sourced/sinked to and from the TxDL and RxDL pins, by enabling the corresponding pulses in either gapped clocks or enable low signals provided at the RxDLC and TxDLC pins. The option of either gapped clock or enable signal is selected by control bit DLCK (Register address Y06).

In D4 or ESF mode, the optional serial data link operates at 4 khz. In D4 mode the data link pins are used to send/receive Fs bits only, while the Ft bits are generated internally. See Figures 40 to 43.

6.1.1.1 T1 Data Link (DL) Pin Data Received from PCM24

The RxDLC clock is derived from the receive extracted clock (EXCLi). The B8ZS decoded receive data, at 1.544Mbit/s, is clocked out of the device on the RxDL pin with the rising edge of EXCLi and is aligned to RXDLC. In order to facilitate the attachment of this data stream to a Data Link controller, the clock signal RxDLC (falling edge of EXCLi) consists of positive pulses, of nominal width of 344 ns, during the Fs bit cell times that are selected for the Data Link, with the rising edge aligned with the middle of the bit cell. DL data will not be lost or repeated when a receive frame slip occurs as the DL data does not pass through the elastic buffer. See Figures 42 to 43 for timing requirements.

6.1.1.2 T1 Data Link (DL) Pin Data Sent to PCM24

The TxDLC clock is derived from the transmit clock (TXCL) and is provided one frame before its usage on the appropriate S-bit. Hence the TXDLC clock is provided one frame before it is used in ESF Mode in Frames 2, 4, 6, 8, 10, 12, 14, 16, 18, 20, 22, 24. See Figures 40 to 41 for timing requirements

6.2 E1 Data Link (DL) Operation

Table 12 shows the contents of the transmit and receive Frame Alignment Signals (FAS) and Non-frame Alignment Signals (NFAS) of timeslot zero of a PCM30 signal. Even numbered frames (CRC Frame # 0, 2, 4,...) are FASs and odd numbered frames (CRC Frame # 1, 3, 5,...) are NFASs. The bits of each channel are numbered 1 to 8, with bit 1 being the most significant and bit 8 the least significant. The Data Link (DL) bits, also referred to as National bits, are the Sa4, Sa5, Sa6, Sa7 and Sa8 bits of the PCM30 timeslot zero NFAS frames. Any number and combination of these bits may be used for the transport of maintenance and performance monitoring information across the PCM30 link. The DataLink is controlled by the address Y06 and Y08.

The received Data Link bits are always sent to the DataLink Pins and the National bit buffers(YC0-YC4)

The Data Link (DL) bits ($S_{a4} \sim S_{a8}$) of the PCM30 timeslot zero NFAS frames can be accessed by the MT9072 in the following four ways:

- External serial port pins. Hence the user can use pins (TxDL and TxDLC) for transmit data link access and RxDL and RXDLC for receive data link access.
- Micro port access which would use Transmit 5 bit register (TNU4-8 address YB0 to YB4). For the receiver Receive 5 bit register (RNU4-8 address YC0-YC4).
- ST-BUS access Transmit ST-BUS (DSTi timeslot 0) enabled by transparent mode.
- On board HDLC for Timeslot 0.

Note: that the user can source different Sa bits from a combination of the above 4 methods. For instance the Sa4 bit could be sourced from the External Serial Port and Sa5 to Sa8 from the micro port register (TNU5-8 address YB1 to YB4).

The registers related to the configuration control and status of the data link are shown in Table 17.

Register Address	Register	Description
Y00	Alarm and Framing Control Register	The Data Link is not supported in the IMA mode.
Y06	HDLC and CCS ST-BUS control register	The bit HPSEL has to be 0 if the internal HDLC is to be used for the Data Link.
Y08	Data Link Control Register	This register determines the source of the Sa bits which can be micro port, HDLC, data link pins or ST-BUS. This register is also used to control the data link pins Txdl and Rxdl.
Y13	NFAS and FAS status	The national use bits RNU can be read from this status register.
Y26	CAS, National, CRC-4 Latched Status	The Sa bit latched values can be read from this register, SA5VL, SA6NL etc.
Y36	CAS, National, CRC-4 Interrupt Status	The Sa bit interrupt values can be read from this register, SA5VI, SA6NI etc.
Y46	CAS, National, CRC-4 Interrupt Mask	These are the mask bits for Y36.
YB0-YB4	Transmit National Bits	Transmit national bits used for sending Sa bits(SA4 to SA8).
YC0-YC4	Receive national bit	Receive National bits(SA4 to SA8)

Table 17 - Data Link and Sa bits Configuration and Status Registers (E1)

6.2.1 E1 Data Link (DL) Pin Access

The pin (TxDL, TxDLC, RxDL and RxDLC) enable bits Sa4SS to Sa8SS of control register address Y08 determine the type of data link access enabled. A '01' code enables the corresponding data link (DL) bits to be sourced to and from the RxDL and TxDL pins, by enabling the corresponding pulses in either gapped clocks or enable low signals provided at the RxDLC and TxDLC pins. The option of either gapped clock or enable signal is selected by control bit DLCK (register address Y08). The data link bits are transmitted on and received from the PCM30 link, in the national bit (Sa4 to Sa8) positions (four to eight of timeslot zero) of the Non-Frame Alignment Signal (NFAS) frames. The gapped clock rate will be either 4, 8, 12, 16 or 20kb/s, and will depend on the number of Sa bits enabled by SA#SS bits (register Y08). Similarly the enable pulse width(s) will also depend on the number of Sa bits enabled.

6.2.1.1 E1 Data Link (DL) Pin Data Transmitted on PCM30

Data to be transmitted onto the line in the S_a bit position is clocked in from the TxDL pin with the TxDLC clock. Although the aggregate clock rate equals the bit rate, it has a nominal pulse width of 244 ns, and it clocks in the TxDL as if it were a 2.048Mbit/s data stream. The clock can only be active during bit times 4 to 0 of the ST-BUS frame. The TxDL input signal is clocked into the MT9072 by the falling edge of TxDLC which occurs about 3/4 into the ST-BUS bit cell. If DL bits are selected to be accessed through the DL pins, then all other programmed functions for those S_a bit positions are overridden. See Figures 59 & 60 for timing requirements.

6.2.1.2 E1 Data Link (DL) Pin Data Received on PCM30 - With No Elastic Buffer

The RxDLC clock and enable signal is derived from the receive extracted clock (EXCLi) and is aligned with the receive data link output RxDL. The HDB3 decoded receive data, at 2.048Mbit/s, is clocked out of the device on the RxDL pin with the falling edge of EXCLi. In order to facilitate the attachment of this data stream to a Data Link controller, the clock signal RxDLC consists of positive pulses, of nominal width of 244 ns, during the S_a bit cell times that are selected for the data link, with the rising edge aligned with the middle of the bit cell. No DL data will be lost or repeated when a receive frame slip occurs as the DL data does not pass through the elastic buffer. The output signal at the RxDLC pin may be either a clock or an enable signal as programmed by the DLCK control bit (register address Y08). See Figures 62 & 63 for timing requirements.

6.2.1.3 E1 Data Link (DL) Pin Data Received on PCM30 - With Elastic Buffer

In this case, the TxDLC pin is used for both DL data transmitted on the PCM30 link and DL data received on the PCM30 link. However, instead of using the non-buffered data output at the RxDL pin, the buffered DSTo output data is used. The clock at the TxDLC pin clocks data from the DSTo ST-BUS stream into an external controller, or the enable signal at the TxDLC pin enables a 2.048Mbit/s clock which clocks data from the DSTo ST-BUS stream into an external controller. Since a common clock is used for both transmit and receive, a simpler data controller may be used such as the MT8952B. However, DL data will be lost or repeated when a receive frame slip occurs, as the DL data does pass through the elastic buffer. See Figures 59 - 60 for timing requirements.

6.2.2 E1 Data Link (DL) National Bit Buffer Access

When the National Bit Buffer transmit data registers access is enabled, the settings of 40 data bits in 5 registers (address YB0-YB4) determine the Data Link (DL) output on the PCM30 link corresponding to bit positions Sa4-8 over one complete CRC-4 Multiframe. The CRC-4 alignment status bit CALN (register address Y11) and corresponding maskable interrupt status bit CALNI (register address Y36) indicate the beginning of every received CRC-4 multiframe. Data for DL transmission should be written to the National Bit Buffer transmit data registers immediately following the CALN status indication (during basic frame 0) and before the start of basic frame 1.

Table 18 illustrates the organization of the MT9072 transmit and receive national bit buffers. Each row is an addressable byte of the MT9072 national bit buffer, and each column contains the national bits of an odd numbered frame of each CRC-4 Multiframe. The transmit and receive national bit buffers are located at addresses YB0 to YB4 and YC0 to YC4 respectively.

Addressable Bytes				NFAS Frames of a CRC-4 Multiframe							
Transmit	Address	Receive	Address	F1 B7	F3 B6	F5 B5	F7 B4	F9 B3	F11 B2	F13 B1	F15 B0
TN0	YB0	RN0	YC0	S _{a4}	S _{a4}	S _{a4}	S _{a4}	S _{a4}	S _{a4}	S _{a4}	S _{a4}
TN1	YB1	RN1	YC1	S _{a5}	S _{a5}	S _{a5}	S _{a5}	S _{a5}	S _{a5}	S _{a5}	S _{a5}
TN2	YB2	RN2	YC2	S _{a6}	S _{a6}	S _{a6}	S _{a6}	S _{a6}	S _{a6}	S _{a6}	S _{a6}
TN3	YB3	RN3	YC3	S _{a7}	S _{a7}	S _{a7}	S _{a7}	S _{a7}	S _{a7}	S _{a7}	S _{a7}
TN4	YB4	RN4	YC4	S _{a8}	S _{a8}	S _{a8}	S _{a8}	S _{a8}	S _{a8}	S _{a8}	S _{a8}

Table 18 - MT9072 National Bit Buffers (E1)

For the National Bit Buffer transmit registers DL access to be enabled the SA4SS to SA8SS(register Y08) are set to 00.

Similarly, the DL data received on the PCM30 link is output to the National Bit Buffer receive data registers (register address YC0-YC4), corresponding to bit positions as shown in Table 18. However, the National Bit Buffer receive data registers are always enabled, regardless of the above control bit settings(SA4SS to SA8SS). Received DL Data should be read from the National Bit Buffer receive data registers immediately following the CALN status indication (during basic frame 0) and before the start of basic frame 1.

In order to facilitate conformance to ETS 300 233, three maskable interrupts are available for change of state of Sa bits in the receive National Bit Buffer. These include Eight Consecutive Sa6 Nibbles (Sa6N8), Sa6 Nibble Change (Sa6N) and Sa Nibble Change (SaN). See the detailed descriptions for these status bits provided in the CAS, National, CRC-4 Local and Timer Interrupt Status Register (address Y36).

6.2.3 E1 Data Link (DL) ST-BUS Access

When the ST-BUS Data Link (DL) access is enabled, the setting of the 8 ST-BUS DSTi data bits determine the Data Link (DL) output on the PCM30 link corresponding to bit positions one to three and Sa4-8 over each Non-

Frame Alignment Signal (NFAS) frame. Data for DL transmission should be written to DSTi immediately following the NFAS frame (during FAS frames) and before the start of the next NFAS frame.

The ST-BUS Data Link (DL) access is enabled if the Sa Source Select Bits (Sa4SS-SA8SS) are set to '10' in register Y08. ST-BUS DSTi timeslot 0 bits will be transmitted as NFAS bits on the PCM30 link, as shown in Table 19 (bit positions one to eight of timeslot zero, of odd CRC-4 frames 1, 3, 5, 7, 9, 11, 13, 15).

The DL data received on the PCM30 link is always output to ST-BUS DSTo timeslot 0 during NFAS frames, regardless of the settings of SA4SS to SA8SS.

ST-BUS DSTi			PCM30 Transmit		
CRC-4 Frame	Timeslot	Data Bits (B7-B0)	Timeslot	CRC-4 Frame	Data Bits (B1-B8)
All NFAS	n	P1, P2, P3, Sa4, Sa5, Sa6, Sa7, Sa8	0	All NFAS	P1, P2, P3, Sa4, Sa5, Sa6, Sa7, Sa8

Note 1. For 2.048Mbit/s operation, n=0.
 Note 2. For 8.192Mbit/s operation, n =0,1,2,3 where n corresponds to the framer number (i.e. n=0=framer 0... n=3= framer 3).
 Note 3. To source the NFAS, Sa bits from DSTi, ST-BUS mode access must be enabled (SA4SS to SA8SS = 10 register address Y08).

Table 19 - Transmit PCM30 National Bits from ST-BUS 2.048Mbit/s or 8.192Mbit/s DSTi (E1)

6.2.4 E1 Timeslot 0 CRC-4 NFAS Receive from PCM30 to DSTo

Non-Frame Alignment Signal (NFAS) bits on the receive PCM30 link (bit positions one to eight of timeslot 0 of odd CRC-4 frames 1, 3, 5, 7, 9, 11, 13, 15) are sourced to the ST-BUS DSTo stream. The data to DSTo is mapped unaltered from the receive PCM30 link as shown in Table 20.

ST-BUS DSTo			PCM30 Receive		
CRC-4 Frame	Timeslot	Data Bits (B7-B0)	Timeslot	CRC-4 Frame	Data Bits (B1-B8)
All NFAS	n	P1, P2, P3, Sa4, Sa5, Sa6, Sa7, Sa8	0	All NFAS	P1, P2, P3, Sa4, Sa5, Sa6, Sa7, Sa8

Note 1. For 2.048Mbit/s operation, n=0.
 Note 2. For 8.192Mbit/s operation, n =0,1,2,3 where n corresponds to the framer number (i.e. n=0=framer 0... n=3= framer 3).
 Note 3. For these functions to be valid, NFAS DSTi ST-BUS mode access must be enabled (SA4SS to SA8SS register address Y08).
 Note 4. For these functions to be valid, the Timeslot Control Registers must be disabled (all bits=0 register address Y90-YAF).

Table 20 - Receive PCM30 National Bits to ST-BUS 2.048Mbit/s or 8.192Mbit/s DSTo (E1)

6.3 T1 Bit Oriented Message

Bit Oriented Messages can be sent on the FDL in ESF mode.

Bit - Oriented Messages may be transmitted via the TxBOM register (Y07) and received in the RxBOM (Y12). Transmission is enabled by setting bit 2 - BOMEn in the HDLC &Data link Control Word(Y06). Bit - oriented messages may be periodically interrupted (up to once per second) for a duration of up to 100 milliseconds. This is to accommodate bursts of message - oriented protocols. Table 21 shows the messages that can be sent and received according to T1.403. The transmit data link will contain the repeating serial data stream 11111110xxxxxx0 where the byte 0xxxxxx0 originates from the user programmed register "Transmit Bit Oriented Message" - Y07. The receive BOM register "Receive Bit Oriented Message" - Y12, will contain the last received valid message (the 0xxxxxx0 portion of the incoming serial bit stream). To prevent spurious inputs from creating false messages, a new message must be present in 8 of the last 10 appropriate byte positions before being loaded into the receive BOM register. When a new message has been received, a maskable interrupt (maskable by setting bit 4 low in Receive Line status and Timer Mask (Y45) may occur. Bit oriented messages are only applicable in the ESF mode.

A Bit oriented match register is available RXBOMM(Y08) and a maskable interrupt can be generated when the received Bit Oriented Message matches the contents of RXBOMM; the mask can be enabled by writing a '0' to bit 3 of the Receive Line and Timer Interrupt Mask Register (Y45).

Octet #	8	7	6	5	4	3	2	1	Octet Content
1	F	L	A	G					01111110
2	S	A	P	I		C / R		EA	00111000 or 00111010
3	T	E	I					EA	00000001
4	C	O	N	T	R	O	L		00000011
5	G3	LV	G4	U1	U2	G5	SL	G6	t0
6	FE	SE	LB	G1	R	G2	Nm	NI	t0
7	G3	LV	G4	U1	U2	G5	SL	G6	t0-1
8	FE	SE	LB	G1	R	G2	Nm	NI	t0-1
9	G3	LV	G4	U1	U2	G5	SL	G6	t0-2
10	FE	SE	LB	G1	R	G2	Nm	NI	t0-2
11	G3	LV	G4	U1	U2	G5	SL	G6	t0-3
12	FE	SE	LB	G1	R	G2	Nm	NI	t0-3
13	F	C	S						Frame Check
14									Sequence

Table 21 - T1.403 and T1.408 Message Oriented Performance Report Structure (T1)

Note: ADDRESS INTERPRETATION

00111000 SAPI = 14, C/R = 0 (CI) EA = 0

00111010 SAPI = 14, C/R = 1(Carrier) EA = 0

00000001 TEI = 0, EA = 1

CONTROL INTERPRETATION

00000011 Unacknowledged Information Transfer

ONE SECOND REPORT INTERPRETATION

G1 = 1 CRC Error Event =1

G2 = 1 1 < CRC Error Event < 5

G3 = 1 5 < CRC Error Event < 10

G4 = 1 10 < CRC Error Event < 100

G5 = 1 100 < CRC Error Event < 319

G6 = 1 CRC Error Event > 320

SE = 1 Severely - Errored Framing Event >=1

FE = 1 Frame Synchronization Bit Error Event >=1

LV = 1 Line code Violation Event >=1

SL = 1 Slip Event >=1

LB = 1 Payload Loopback Activated

U1,U2 = 0 Under Study for sync.

R = 0 Reserved - set to 0

NmNI = 00, 01, 10, 11 One Second Module 4 counter

FCS INTERPRETATION

VARIABLE CRC16 Frame Check Sequence

7.0 Signaling

7.1 T1 Signaling

7.1.1 T1 Robbed Bit Signaling

When global control bit RBEn (Y04, Bit 8) is high the MT9072 will insert ABCD or AB signaling bits into bit 8 of every transmit DS0 every 6th frame if the corresponding per channel Clear Channel bit(CC) is turned off. For the transmitter Robbed bit signaling can be turned off on a per channel basis by setting CC bit in per timeslot control register(Y90-YAF). The AB or ABCD signaling bits from received frames 6 and 12 (AB) or from frames 6, 12, 18 and 24 (ABCD) will be loaded into an internal storage RAM. The transmit AB/ ABCD signaling nibbles can be set either via the microport or through related channels of the CSTi serial links, see ST-BUS vs. PCM24 Channel Relationship in Tables 1 to 2. If the MPST bit is set in the Per Timeslot Control register(Y90-YAF), the transmit signaling is sourced from the microport and not updated from the CSTi channel. If the MPST bit is not set, any values written to the transmit signaling memory will be overwritten by the CSTi stream.

The receive signaling bits are stored in an internal RAM. These bits can be sourced to the CSto streams. The serial control streams that contain the transmit / receive signaling information (CSTi and CSto respectively) can be clocked at 2.048 MHz, or 8.192 MHz(global control0 register 900). In the case of 8.192 MHz the signaling from framer 0 to 3 are sent and received by CSTi0/CSto0 and framer 4 to 7 are sent and received on CSTi4/CSto4. The selection of the CSTi/CSto interface is done by the number of signaling channels to be transmitted / received = 24 (timeslots) x 4 bits per timeslot (ABCD) = 24 nibbles. This leaves many unused nibble positions in the 2.048 MHz CSTi / CSto bandwidth. These unused nibble locations are tristated. The usage of the bit stream is as follows: the signaling bits are inserted / reported in the same CSTi / CSto channels that correspond to the DS1 channels used in DSTi / DSto - see Table 1 to 2. The ABCD are in the least significant nibble of each channel. Unused nibbles and timeslots are tristate. In order to facilitate multiplexing on the CSto control stream, an additional control bit CStoEn (bit 1 of the interrupt and IO Control Word YF1) will tristate the whole stream when set low. This control bit is forced low when the reset pin is asserted. In the case of D4 trunks, only AB bits are reported. The control bits SM1-0(Register Y04) allow the user to program the 2 unused bits reported on CSto in the signaling nibble(for D4 Mode) otherwise occupied by CD signaling bits in ESF trunks.

A receive signaling bit debounce of 6 msec can be selected (RSDB set high - bit 6 of the signaling Control Word Y04) for all T1 Modes.

If multiframe synchronization is lost (Synchronization and Alarm Status Word(Y10) Bit 12, $\overline{\text{MFSYNC}} = 1$), the receive signaling bits are frozen. They will become unfrozen when multi - frame synchronization is acquired (this is the same as terminal frame synchronization for ESF links).

When the CASRI interrupt is unmasked, $\overline{\text{IRQ}}$ will become active when a signaling state change is detected in any of the 24 receive channels and a selectable 1 msec, 4 msec or 8 msec timer(Y04 bit 0,1) has expired. This function helps to reduce the frequency of interrupts generated due to signaling changes. For instance if 7 channels had a signaling change only one interrupt will be generated in a 2, 8, or 16 msec duration. Upon an interrupt the user has to read the CAS registers(Y70 to Y87)to determine the channels with a signaling change.The CASRIM interrupt mask is located in register Y45 bit 2 (reset low to enable interrupt); and the CASRI interrupt status bit in register is Y35 bit 2. Any channels marked as clear channels will not generate an interrupt due to changes in ABCD bits.

When bit 0 (CC) in the per timeslot control word (Y90 to YA7) is set no bit robbing for the purpose of signaling will occur in this channel and no signaling change interrupts will be generated by the channel. When bit 7 (MPST) is set, the transmit signaling for the addressed channel can only be programmed by writing to the transmit signaling page (Y50 to Y67) via the microport. If MPST is zero, the transmit signaling information is constantly updated with the information from the equivalent channel on CSTi.

Register Address	Register	Description
900	Global Control 0	CK1 determines an 8 Mhz stream or a 2 Mhz stream. \overline{STBUS} selects a GCI or ST-BUS CSTi, CSTo streams.
Y00	Framing Mode Select	The number of signaling bits available is dependent on the mode. For D4 and T1DM 2 bits of signaling, for ESF 4 bits. In G.802 and IMA mode signaling is not supported.
Y04	Signaling Control Word	This register defines the selection between robbed bit or common channel, signaling debounce and substitute bits C,D bits for D4 mode on CSTo. Y04 bit 0 and 1 are used to control the frequency of the signaling change interrupt.
Y0B	Common Channel signaling Map Register	This register is used to determine the CSTi/o channel to PCM24 timeslot mapping for common channel signaling.
Y10	Synchronization and Alarm Status Word	The receive signaling will not work if terminal frame synchronization and multiframe synchronization is not achieved.
Y50-Y60	Per Channel Transmit signaling	The clear channel bit can be used to block insertion of signaling in the transmit direction. The MPST bit can be used to determine the source of the transmit signaling, which is either the CSTi stream or the transmit signaling ram.
Y35	Receive Line and Timer Interrupt Status	The CASRI bit is set if unmasked and receive signaling changes on any channel. The channels marked as clear channel do not generate an interrupt.
Y45	Receive Line and Timer Interrupt Mask	CASRIM is the mask bit for the Y35.

Table 22 - Registers Related to Signaling (T1)

7.1.2 T1 Common Channel Signaling

One 64 Kbit/s channel can be mapped from/to an external multichannel HDLC using the CSTi/o pins. This is accomplished by writing to register Y0B and Y04(CSIGEN bit). Note that only channels 0 to 23 can be used on the CSTi/o streams in Common Channel Signaling applications. For the CSTo stream only the channel that is selected is driven, the rest of the stream is tristate. In 8 Mbit/s mode up to 4 channels per 8Mbit/s CSTi/o stream will be assigned to the external HDLC in accordance with Table 2.

7.2 E1 Signaling

7.2.1 Channel Associated Signaling (CAS) Operation

The purpose of the CAS signaling Multiframing algorithm is to provide a scheme that will allow the association of a specific ABCD signaling nibble with the appropriate PCM30 channel. The signaling nibble when sinked or sourced from the ST-BUS will have the ABCD bits being bits 3 to 0 respectively.

A CAS signaling multiframe consists of 16 basic frames (numbered 0 to 15), which results in a multiframe repetition rate of 2 msec. It should be noted that the boundaries of the signaling multiframe may be completely distinct from those of the CRC-4 multiframe. CAS multiframe alignment is based on a multiframe alignment signal (a 0000 bit sequence), which occurs in the most significant nibble of timeslot 16 of basic frame 0 of the CAS multiframe. Bits 5, 7 and 8 (usually designated X) are spare bits and are normally set to one if not used. Bit 6 of this timeslot is the multiframe alarm bit (usually designated Y). When CAS multiframing is acquired on the receive side, the transmit Y-bit is zero; when CAS multiframing is not acquired, the transmit Y-bit is one. Refer to ITU-T G.704 and G.732 for more details on CAS multiframing requirements. Registers related to configuration and observation of the CAS signaling are shown in Table 23.

Register Address	Register	Description
900	Global Control 0	CK1 determines an 8.192 Mbits stream or a 2.048 Mbits stream. STBUS selects a GCI or ST-BUS CSTi, CSTo streams.
Y00	Alarm and Framing Control Register	Ensure that TAIS16 is off, the signaling information in CAS cannot be sent if TAIS16 is on. Also signaling is not supported in IMA mode.
Y02	Interrupt and IO Control Register	If CSTo is to contain the signaling nibbles set CSTOE to 1 and \overline{RXCO} to 1.
Y03	DL,CCS,CAS and other Control Register	RXTRS which sets the receiver in a transparent mode has to be turned off.
Y04	Signaling Interrupt Period Register	Bit 0 and 1 of this register determine the period of the interrupt CASRI. The period is selectable from 2 msec 8 msec and 16 msec.
Y05	CAS Control and Data Register	If RFL is set the receive signaling is frozen due to synchronization loss. If debounce is selected a 14 msec debounce is applied before the signaling is available in the csto or receive CAS register.
Y06	HDLC and CCS ST-BUS Control Register	TS31E, TS15E and TS16E have to be off since Common Channel signaling and CAS are mutually exclusive.
Y10	Synchronization and CRC-4 Remote Status.	MSYNC has to be low for the signaling in the Receive CAS Registers or CSTO has valid data.
Y26	CAS, National, CRC-4 Local and Timer Latch Status	The bit CASRL reflects the signaling changes on the receive CAS.
Y36	CAS, national, CRC-4 Local and Timer Interrupt Status	The CASRI will be set if a signaling Interrupt has occurred. The period of the interrupt is controlled by the signaling Interrupt Period Register(Y04).
Y46	National Interrupt Mask Register	The bit CASRM can be used to mask interrupts from the receive signaling changes.
Y51-Y6F	Per Channel Transmit Signaling	The clear channel bit can be used to block insertion of signaling in the transmit direction. The CASS bit can be used to determine the source of the transmit signaling, which is either the CSTi or the transmit signaling ram.
Y90 to YAF	Per Channel Timeslot Control Register	The CASS bit determines the source of the transmit signaling which is either the ST-BUS or the transmit signaling registers(Y51 to Y60).

Table 23 - Registers Related to CAS Signaling (E1)

Timeslot 16 of the remaining 15 basic frames of the CAS multiframe (i.e., basic frames 1 to 15) is reserved for the ABCD signaling bits for the 30 payload channels. The most significant nibbles are reserved for channels 1 to 15 and the least significant nibbles are reserved for channels 16 to 30. That is, timeslot 16 of basic frame 1 has ABCD for channel 1 and 16, timeslot 16 of basic frame 2 has ABCD for channel 2 and 17, through to timeslot 16 of basic frame 15 has ABCD for channel 15 and 30. See Table 24. Note that the ABCD bits for TS1 to TS15 should not be 0000 to prevent mimic of the multiframe alignment signal(0000).

	CAS Frame	PCM30 Timeslot 16							
		1	2	3	4	5	6	7	8
Channel Associated signaling (CAS) Multiframe (not related to CRC-4 multiframeing)	0	0000 (MAS)				XYXX (NMAS)			
	1	ABCD (ch 1 = ts1)				ABCD (ch 16 = ts 17)			
	2	ABCD (ch 2 = ts 2)				ABCD (ch 17 = ts 18)			
	3	ABCD (ch 3 = ts 3)				ABCD (ch 18 = ts 19)			
	4	ABCD (ch 4 = ts 4)				ABCD (ch 19 = ts 20)			
	5	ABCD (ch 5 = ts 5)				ABCD (ch 20 = ts 21)			
	6	ABCD (ch 6 = ts 6)				ABCD (ch 21 = ts 22)			
	7	ABCD (ch 7 = ts 7)				ABCD (ch 22 = ts 23)			
	8	ABCD (ch 8 = ts 8)				ABCD (ch 23 = ts 24)			
	9	ABCD (ch 9 = ts 9)				ABCD (ch 24 = ts 25)			
	10	ABCD (ch 10 = ts 10)				ABCD (ch 25 = ts 26)			
	11	ABCD (ch 11 = ts 11)				ABCD (ch 26 = ts 27)			
	12	ABCD (ch 12 = ts 12)				ABCD (ch 27 = ts 28)			
	13	ABCD (ch 13 = ts 13)				ABCD (ch 28 = ts 29)			
	14	ABCD (ch 14 = ts 14)				ABCD (ch 29 = ts 30)			
	15	ABCD (ch 15 = ts 15)				ABCD (ch 30 = ts 31)			

MAS - Multiframe Alignment Signal
 NMAS - Non-multiframe Alignment Signal
 X - Spare Bit = 1 if not used
 Y - Remote Multiframe Alarm Signal

Table 24 - Channel Associated Signaling (CAS) Multiframe Structure (E1)

7.2.2 E1 Channel Associated Signaling (CAS) Register and ST-BUS Access

The CSIG control bit (register address Y03) must be set to zero for Channel Associated signaling (CAS) operation.

Access to the ABCD transmit and receive bits may be either through ST-BUS channels 1 to 15 and channels 17 to 31 at the CSTi and CSTo pins, or through the Transmit CAS Data registers (Y51-Y6F) and Receive CAS Data registers (Y71-Y8F) accessed by the parallel processor port, or through a mix of both methods. The timeslot control register bits (CASS(n) address Y90-YAF) determine the source of the CAS data on a per channel basis. A zero enables an ST-BUS source and a one enables a register source. Note that when changing the CASS(n) control bits from ST-BUS source to register source on the fly (during normal operation as opposed to during power up), the data in the Transmit CAS Data registers (Y51-Y6F) should be updated one frame after the timeslot control register bits (CASS(n)) are changed. This is because the timeslot control register bits do not take effect immediately. Both destinations of CAS data are always enabled (i.e. ST-BUS CSTo and receive data registers). ST-BUS CSTi and CSTo channels 0 and 16 are not used.

When the CASRI interrupt is unmasked, $\overline{\text{IRQ}}$ will become active when a signaling state change is detected in any of the 30 receive channels and a selectable 2 msec, 8 msec or 16 msec timer (Y04 bit 0,1) has expired. This function helps to reduce the frequency of interrupts generated due to signaling changes. For instance if 7 channels had a signaling change only one interrupt will be generated in a 2,8 or 16 msec duration. Upon an interrupt the user has to read the CAS registers (Y70 to Y8F) to determine the channels with a signaling change. The CASRIM interrupt mask is located in register Y46 bit 4 (clear to enable interrupt); and the CASRI interrupt status bit in register Y36 bit 4. Any channels marked as clear channels will not generate an interrupt due to changes in ABCD bits.

7.2.2.1 E1 Channel Associated Signaling (CAS) Transmit from ST-BUS CSTi to PCM30

Table 25 shows the detailed bit mapping of CSTi timeslots to transmit PCM30 frames.

Frame	ST-BUS CSTi		PCM30 Transmit	
	Timeslot	Data Bits (B7-B0)	Timeslot	Data Bits (B1-B8)
0	0 + n	not used.	16	CAS Multiframe Alignment Signal
	1m + n to 15m + n	###,###,A1, B1, C1, D1 to ###,###,A15, B15, C15, D15		
	16m + n	not used.		
	17m + n to 31m + n	###,###,A16, B16, C16, D16, to ###,###,A30, B30, C30, D30		
1 to 15	as above	as above	16	A1, B1, C1, D1, A16, B16, C16, D16 to A15, B15, C15, D15, A30, B30, C30, D30

Note 1. For 2.048Mbit/s operation, m=1 and n=0.
 Note 2. For 8.192Mbit/s operation, m=4 and n =0,1,2,3 where n corresponds to the framer number (i.e. n=0=framer 0... n=3= framer 3)
 Note 3. The number following the ABCD signaling bit letter designates the channel number (i.e. A30 designates channel 30).
 Note 4. For these functions to be valid, CAS mode must be selected (CSIG=0 register address Y03), and the required ST-BUS channels must be enabled (CASS=0 of register address Y90-YAF).
 Note 5. # indicates data which is not transmitted.

Table 25 - Transmit PCM30 CAS Channels 1 to 30 from ST-BUS 2.048Mbit/s or 8.192Mbit/s CSTi (E1)

7.2.2.2 E1 Channel Associated Signaling (CAS) Receive from PCM30 to ST-BUS CSTo

Table 26 shows the detailed bit mapping of CSTo timeslots from receive PCM30 frames.

CAS Frame	ST-BUS CSTo		PCM30 Receive	
	Timeslot	Data Bits (B7-B0)	Timeslot	Data Bits (B1-B8)
0	0 + n	not used.	16	CAS Multiframe Alignment Signal
	1m + n to 15m + n	1,1,1,1,A1, B1, C1, D1, to 1,1,1,1,A15, B15, C15, D15		
	16m + n	not used.		
	17m + n to 31m + n	1,1,1,1,A16, B16, C16, D16, to 1,1,1,1,A30, B30, C30, D30		
1 to 15	as above	as above	16	A1, B1, C1, D1, A16, B16, C16, D16 to A15, B15, C15, D15, A30, B30, C30, D30

Note 1. For 2.048Mbit/s operation, m=1 and n=0.
 Note 2. For 8.192Mbit/s operation, m=4 and n =0,1,2,3 where n corresponds to the framer number (i.e. n=0=framer 0... n=3= framer 3).
 Note 3. The number following the ABCD signaling bit letter designates the channel number (i.e. A30 designates channel 30).
 Note 4. For these functions to be valid, CAS mode must be selected (CSIG=0 register address Y03).
 Note 5. "1" indicates bit positions in a logic high state.

Table 26 - Receive PCM30 CAS Channels 1 to 30 to ST-BUS 2.048Mbits or 8.192Mbits CSTo (E1)

7.2.3 E1 Common Channel Signaling (CCS) Transmit from ST-BUS CSTi and DSTi to PCM30

The CSIG control bit (register address Y03) must be set to one for Common Channel signaling (CCS) operation. CCS on the transmit PCM30 link (bit positions one to eight of timeslots 15, 16 and/or 31 of every frame) may be sourced from the ST-BUS DSTi stream or from the ST-BUS CSTi stream. If the TS15E, TS16E & TS31E control bits (register address Y06) are zero, the transmit data will be sourced from the ST-BUS DSTi stream timeslots 15, 16 and 31, if these bits are one, then the signaling data will be sourced from the ST-BUS CSTi stream. Note that any combination of the TS15E, TS16E & TS31E control bits (register address Y06) may be enabled. The CSTi source timeslots for the PCM30 timeslot 15, 16 and 31, are determined respectively by the 15C4-15C0, 16C4-31C0 and 31C4-31C0 (register address Y07) programming bits. Table 27 shows the

detailed bit mapping of CSTi timeslots to transmit PCM30 frames. Table 28 shows the detailed bit mapping of DSTi timeslots to transmit PCM30 frames.

ST-BUS CSTi			PCM30 Transmit		
CRC-4 Frame	Timeslot	Data Bits (B7-B0)	Timeslot	CRC-4 Frame	Data Bits (B1-B8)
all	Any one of 32 n + m(0 to 31)	P1, P2, P3, P4, P5, P6, P7, P8	15	all	P1, P2, P3, P4, P5, P6, P7, P8
all	Any one of 32 n + m(0 to 31)	P1, P2, P3, P4, P5, P6, P7, P8	16	all	P1, P2, P3, P4, P5, P6, P7, P8
all	Any one of 32 n + m(0 to 31)	P1, P2, P3, P4, P5, P6, P7, P8	31	all	P1, P2, P3, P4, P5, P6, P7, P8

Note 1. For 2.048Mbit/s operation, m=1 and n=0.
 Note 2. For 8.192Mbit/s operation, m=4 and n =0,1,2,3 where n corresponds to the framer number (i.e. n=0=framer 0... n=3= framer 3)
 Note 3. For these functions to be valid, CCS mode must be selected (CSIG=1 register address Y03), and CSTi ST-BUS mode must be selected (TS15E=1, TS16E=1 & TS31E=1 register address Y06), and the preferred source CSTi timeslot should be selected (15C4-0, 16C4-0 & 31C4-0 register address Y07).

Table 27 - Transmit PCM30 CCS from ST-BUS 2.048Mbit/s or 8.192Mbit/s CSTi (E1)

ST-BUS DSTi			PCM30 Transmit		
CRC-4 Frame	Timeslot	Data Bits (B7-B0)	Timeslot	CRC-4 Frame	Data Bits (B1-B8)
all	n + m(15)	P1, P2, P3, P4, P5, P6, P7, P8	15	all	P1, P2, P3, P4, P5, P6, P7, P8
all	n + m(16)	P1, P2, P3, P4, P5, P6, P7, P8	16	all	P1, P2, P3, P4, P5, P6, P7, P8
all	n + m(31)	P1, P2, P3, P4, P5, P6, P7, P8	31	all	P1, P2, P3, P4, P5, P6, P7, P8

Note 1. For 2.048Mbit/s operation, m=1 and n=0.
 Note 2. For 8.192Mbit/s operation, m=4 and n =0,1,2,3 where n corresponds to the framer number (i.e. n=0=framer 0... n=3= framer 3).
 Note 3. For these functions to be valid, CCS mode must be selected (CSIG=1 register address Y03), and DSTi ST-BUS mode must be selected (TS15E=0, TS16E=0 & TS31E=0 register address Y06).

Table 28 - Transmit PCM30 CCS from ST-BUS 2.048Mbit/s or 8.192Mbit/s DSTi (E1)

7.2.4 E1 Common Channel Signaling (CCS) Receive from PCM30 to CSTo and DSTo

The CSIG control bit (register address Y03) must be set to one for Common Channel signaling (CCS) operation. CCS on the receive PCM30 link (bit positions one to eight of timeslots 15, 16 and/or 31 of every frame) is sourced to the ST-BUS DSTo stream and may also be sourced to the ST-BUS CSTo stream. If the TS15E, TS16E & TS31E control bits (register address Y06) are zero, the receive data will be sourced to the ST-BUS DSTo stream only, timeslots 15, 16 and 31. If these bits are one, then the signaling data will be sourced to both the DSTo stream and the ST-BUS CSTo stream. Note that any combination of the TS15E, TS16E & TS31E control bits (register address Y06) may be enabled. The CSTo destination timeslots for the receive PCM30 timeslots 15, 16 and 31, are determined respectively by the 15C4-15C0, 16C4-31C0 and 31C4-31C0 (register address Y07) programming bits. Table 29 shows the detailed bit mapping of CSTo timeslots from receive PCM30 frames. Table 30 shows the detailed bit mapping of DSTo timeslots from receive PCM30 frames.

ST-BUS CSto			PCM30 Receive		
CRC-4 Frame	Timeslot	Data Bits (B7-B0)	Timeslot	CRC-4 Frame	Data Bits (B1-B8)
all	Any one of 32 n + m(0 to 31)	P1, P2, P3, P4, P5, P6, P7, P8	15	all	P1, P2, P3, P4, P5, P6, P7, P8
all	Any one of 32 n + m(0 to 31)	P1, P2, P3, P4, P5, P6, P7, P8	16	all	P1, P2, P3, P4, P5, P6, P7, P8
all	Any one of 32 n + m(0 to 31)	P1, P2, P3, P4, P5, P6, P7, P8	31	all	P1, P2, P3, P4, P5, P6, P7, P8

Note 1. For 2.048Mbit/s operation, m=1 and n=0.
 Note 2. For 8.192Mbit/s operation, m=4 and n =0,1,2,3 where n corresponds to the framer number (i.e. n=0=framer 0... n=3= framer 3)
 Note 3. For these functions to be valid, CCS mode must be selected (CSIG=1 register address Y03), and CSto ST-BUS mode must be selected (TS15E=1, TS16E=1 & TS31E=1 register address Y06), and the preferred destination CSto timeslot should be selected (15C4-0, 16C4-0 & 31C4-0 register address Y07).

Table 29 - Receive PCM30 CCS to ST-BUS 2.048Mbit/s or 8.192Mbit/s CSto (E1)

ST-BUS DSto			PCM30 Receive		
CRC-4 Frame	Timeslot	Data Bits (B7-B0)	Timeslot	CRC-4 Frame	Data Bits (B1-B8)
all	n + m(15)	P1, P2, P3, P4, P5, P6, P7, P8	15	all	P1, P2, P3, P4, P5, P6, P7, P8
all	n + m(16)	P1, P2, P3, P4, P5, P6, P7, P8	16	all	P1, P2, P3, P4, P5, P6, P7, P8
all	n + m(31)	P1, P2, P3, P4, P5, P6, P7, P8	31	all	P1, P2, P3, P4, P5, P6, P7, P8

Note 1. For 2.048Mbit/s operation, m=1 and n=0.
 Note 2. For 8.192Mbit/s operation, m=4 and n =0,1,2,3 where n corresponds to the framer number (i.e. n=0=framer 0... n=3= framer 3)
 Note 3. For these functions to be valid, CCS mode must be selected (CSIG=1 register address Y03).

Table 30 - Receive PCM30 CCS to ST-BUS 2.048Mbit/s or 8.192Mbit/s DSto (E1)

7.2.5 CCS (Timeslot 16) Programming Options Summary Table

Control		Data Source			Data Destination		
Bit	Register	Method	*Bits	Timeslot or Register	Method	*Bits	Timeslot or Register
CSIG=1	Y03	ST-BUS CSTi	P1-P8	any n where n=0-31	PCM30 TPOS-TNEG	P1- P8	15
TS15E=1	Y06						
15C4-0=n	Y07						
CSIG=1	Y03			any n where n=0-31			16
TS15E=1	Y06						
16C4-0=n	Y07						
CSIG=1	Y03			any n where n=0-31			31
TS15E=1	Y06						
31C4-0=n	Y07						
CSIG=1	Y03	ST-BUS DSTi		15			15
TS15E=0	Y06						
CSIG=1	Y03			16			16
TS16E=0	Y06						
CSIG=1	Y03			31			31
TS31E=0	Y06						
CSIG=1	Y03	PCM30 RPOS-RNEG		15	ST-BUS CSTo		any nwhere n=0-31
TS15E=1	Y06						
15C4-0=n	Y07						
CSIG=1	Y03			16			any n where n=0-31
TS16E=1	Y06						
16C4-0=n	Y07						
CSIG=1	Y03			31			any n where n=0-31
TS31E=1	Y06						
31C4-0=n	Y07						
CSIG=1	Y03		all n where n=0-31	ST-BUS DSTo			all n where n=0-31

* Notes
 1. ST-BUS "Bits" are from MSB (B7) to LSB (B0) with P1 the MSB
 2. PCM30 "Bits" are from MSB (B1) to LSB (B8) with P1 the MSB

Table 31 - CCS (Timeslot 15, 16 & 31) Source and Destination Summary Table (E1)

8.0 HDLC

The MT9072 has 1 embedded HDLC controller for each of the framers. Each controller may be attached to any timeslot. The HDLC can also be connected to the FDL bits (T1 ESF Mode) for provision of a 4 Kbit/s Data Link or Sa bits in E1 mode for data link up to 20Kb/s.

The features of the HDLC are:

- Independent transmit and receive FIFO;
- Receive FIFO maskable interrupts for nearly full and overflow conditions;
- Transmit FIFO maskable interrupts for nearly empty and underflow conditions;
- Maskable interrupts for transmit end-of-packet and receive end-of-packet;
- Maskable interrupts for receive bad-frame (includes frame abort);
- Transmit end-of-packet and frame-abort functions.

The relevant registers associated with HDLC are listed in Table 32.

Register Address	Register	Description
Y06	HDLC and DataLink Control	The bits of this register determine whether the HDLC is connected to the Data Link or payload.
YF2	HDLC Control	General configuration for the HDLC.
YF3	HDLC Test Control	Control bits for testing the HDLC such as loopbacks.
YF4	Address Recognition	Address recognition register for storing data in the Receive FIFO of a packet that matches the received address.
YF5	Transmit FIFO	This register is used for writing data to the HDLC Transmit FIFO. The data from the FIFO can be subsequently sent to Data Link or a selected channel.
YF6	Transmit Byte Counter	This counter determines the size of the HDLC packet to be sent when the cycle bit is set(YF2).
Y1D	HDLC Status	This register provides status on the FIFO's.
Y1E	Receive CRC	This register provides the received FCS of a packet.
Y1F	Receive FIFO	This register has to be read to obtain the receive FIFO data.
Y23	HDLC Latch Status	These register bits are the latched version of the HDLC status.
Y33	HDLC Interrupt Status	This register provides the interrupt status of events such as underflow, go ahead packet etc.
Y43	HDLC Interrupt Mask	These register bits can be used to mask HDLC events to cause interrupts.

Table 32 - HDLC Related Registers

8.1 HDLC Description

The HDLC handles the bit oriented protocol structure as per layer 2 of the switching protocol X.25 defined by CCITT. It transmits and receives the packetized data serially while providing data transparency by zero insertion and deletion. It generates and detects the flags, various link channel states and abort sequences. Further, it provides a cyclic redundancy check on the data packets using the CCITT defined polynomial. In addition, it can recognize a single byte, dual byte and all call address in the received frame. Access to Rx CRC

and inhibiting of Tx CRC for terminal adaptation is also provided. The HDLC controller has two 32 byte deep FIFO's associated with it; one for Transmit and one for Receive.

8.1.1 HDLC Frame Structure

A valid HDLC frame begins with an opening flag, contains at least 16 bits of address and control or information, and ends with a 16 bit FCS followed by a closing flag. Data formatted in this manner is also referred to as a "packet". Refer to Table 33.

Flag (7E)	Data Field	FCS	Flag (7E)
One Byte 01111110	n Bytes $n \geq 2$	Two Bytes	One Byte 01111110

Table 33 - HDLC Frame Format

All HDLC frames start and end with a unique flag sequence "01111110". The transmitter generates these flags and appends them to the packet to be transmitted. The receiver searches the incoming data stream for the flags on a bit-by-bit basis to establish frame synchronization.

The data field consists of an address field, control field and information field. The address field consists of one or two bytes directly following the opening flag. The control field consists of one byte directly following the address field. The information field immediately follows the control field and consists of N bytes of data. The HDLC does not distinguish between the control and information fields and a packet does not need to contain an information field to be valid.

The FCS field, which precedes the closing flag, consists of two bytes. A cyclic redundancy check utilizing the CRC-CCITT standard generator polynomial " $X^{16}+X^{12}+X^5+1$ " produces the 16-bit FCS. In the transmitter the FCS is calculated on all bits of the address and data field. The complement of the FCS is transmitted, most significant bit first, in the FCS field. The receiver calculates the FCS on the incoming packet address, data and FCS field and compares the result to "F0B8". If no transmission errors are detected and the packet between the flags is at least 32 bits in length then the address and data are entered into the receive FIFO minus the FCS which is discarded.

8.1.2 Data Transparency (Zero Insertion/Deletion)

Transparency ensures that the contents of a data packet do not imitate a flag, go-ahead, frame abort or idle channel. The contents of a transmitted frame, between the flags, is examined on a bit-by-bit basis and a 0 bit is inserted after all sequences of 5 contiguous 1 bits (including the last five bits of the FCS). Upon receiving five contiguous 1s within a frame the receiver deletes the following 0 bit.

8.1.3 Invalid Frames

A frame is invalid if one of the following four conditions exists (Inserted zeros are not part of a valid count):

- If the FCS pattern generated from the received data does not match the "F0B8" pattern then the last data byte of the packet is written to the received FIFO with a 'bad packet' indication.
- A short frame exists if there are less than 25 bits between the flags. Short frames are ignored by the receiver and nothing is written to the receive FIFO.
- Packets which are at least 26 bits in length but less than 32 bits between the flags are also invalid. In this case the data is written to the FIFO but the last byte is tagged with a "bad packet" indication.
- If a frame abort sequence is detected the packet is invalid. Some or all of the current packet will reside in the receive FIFO, assuming the packet length before the abort sequence was at least 25 bits long.

8.1.4 Frame Abort

The transmitter will abort a current packet by substituting a zero followed by seven contiguous 1s in place of the normal packet. The receiver will abort upon reception of seven contiguous 1s occurring between the flags of a packet which contains at least 25 bits.

Note that should the last received byte before the frame abort end with contiguous 1s, these are included in the seven 1s required for a receiver abort. This means that the location of the abort sequence in the receiver may

occur before the location of the abort sequence in the originally transmitted packet. If this happens then the last data written to the receive FIFO will not correspond exactly with the last byte sent before the frame abort.

8.1.5 Interframe Time Fill and Link Channel States

When the HDLC transmitter is not sending packets it will wait in one of two states

- Interframe Time Fill state: This is a continuous series of flags occurring between frames indicating that the channel is active but that no data is being sent.
- Idle state: An idle Channel occurs when at least 15 contiguous 1s are transmitted or received.

In both states the transmitter will exit the wait state when data is loaded into the transmitter FIFO.

8.1.6 Go-Ahead

A go ahead is defined as the pattern "01111110" (contiguous 7Fs) and is the occurrence of a frame abort sequence followed by a zero, outside of the boundaries of a normal packet. Being able to distinguish a proper (in packet) frame abort sequence from one occurring outside of a packet allows a higher level of signaling protocol which is not part of the HDLC specifications.

8.1.7 Functional Description

The HDLC transceiver can be reset by either the power reset input signal or by the HRST Control bit in the HDLC Test control register (YF3). When reset, the HDLC Control Registers are cleared, resulting in the transmitter and receiver being disabled. The Receiver and Transmitter can be enabled independent of one another through HDLC control (YF2 bits RXEN and TXEN). The transceiver input and output are enabled when the enable control bits in HDLC control are set. Transmit to receive loopback as well as a receive to transmit loopback are also supported. Transmit and receive bit rates and enables can operate independently.

Received packets from the serial interface, are sectioned into bytes by an HDLC receiver that detects flags, checks for go-ahead signals, removes inserted zeros, performs a cyclical redundancy check (CRC) on incoming data, and monitors the address if required. Packet reception begins upon detection of an opening flag. The resulting bytes are concatenated with two status bits (RQ9, RQ8 in HDLC status register Y1D) and placed in a receiver first-in-first-out (Rx FIFO); a buffer register that generates status and interrupts for microprocessor read control.

In conjunction with the control circuitry, the microprocessor writes data bytes into a Tx buffer register (Tx FIFO) that generates status and interrupts. Packet transmission begins when the microprocessor writes a byte to the Tx FIFO. Two status bits are added to the Tx FIFO for transmitter control of frame aborts (FA) and end of packet (EOP) flags. Packets have flags appended, zeros inserted, and a CRC, also referred to as frame checking sequence (FCS), added automatically during serial transmission. When the Tx FIFO is empty and finished sending a packet, Interframe Time Fill bytes (continuous flags (7E hex)), or Mark Idle (continuous ones) are transmitted to indicate that the channel is idle.

8.1.8 HDLC Transmitter

Following initialization and enabling, the transmitter is in the Idle Channel state (Mark Idle), continuously sending ones. Interframe Time Fill state (Flag Idle) is selected by setting the MI bit in register YF2 high. The Transmitter remains in either of these two states until data is written to the Tx FIFO. YF2 bits EOP (end of packet) and FA (Frame Abort) are set as status bits before the microprocessor loads 8 bits of data into the 10 bit wide FIFO (8 bits data and 2 bits status). To change the tag bits being loaded in the FIFO, HDLC Master Control must be written to before writing to the FIFO. However, EOP and FA are reset after writing to the TX FIFO. The Transmit Byte Count Register (YF6) may also be used to tag an end of packet. The register is loaded with the number of bytes in the packet and decrements after every write to the Tx FIFO. When a count of one is reached, the next byte written to the FIFO is tagged as an end of packet. The register may be made to cycle through the same count if the packets are of the same length by setting HDLC Master Control bit Cycle.

If the transmitter is in the Idle Channel state when data is written to the Tx FIFO, then an opening flag is sent and data from Tx FIFO follows. Otherwise, data bytes are transmitted as soon as the current flag byte has been sent. Tx FIFO data bytes are continuously transmitted until either the FIFO is empty or an EOP or FA status bit is read by the transmitter. After the last bit of the EOP byte has been transmitted, a 16-bit FCS is sent followed by a closing flag. When multiple packets of data are loaded into Tx FIFO, only one flag is sent between packets. When the HDLC is connected to FDL or a transmit channel

The least significant bit of the Transmit FIFO data is sent first on the serial stream.

Frame aborts (the transmission of 7F hex), are transmitted by tagging a byte previously written to the Tx FIFO. When a byte has an FA tag, then an FA is sent instead of that tagged byte. That is, all bytes previous to but not including that byte are sent. After a Frame Abort, the transmitter returns to the Mark Idle or Interframe Time Fill state, depending on the state of the Mark idle control bit.

Tx FIFO underrun will occur if the FIFO empties and the last byte did not have either an EOP or FA tag. A frame abort sequence will be sent when an underrun occurs.

Below is an example of the transmission of a three byte packet ('AA' '03' '77' hex) (Interframe time fill). TXcen can be enabled before or after this sequence.

- | | |
|--|--------------------------------|
| (a) Write '0020' hex to Control Register 1 | -Mark idle bit set |
| (b) Write 'AA' hex to TX FIFO | -Data byte |
| (c) Write '03' hex to TX FIFO | -Data byte |
| (d) Write '01A0' hex to Control Register 1 | -TXEN; EOP; Mark idle bits set |
| (e) Write '77' hex to TX FIFO | -Final data byte |

The transmitter may be enabled independently of the receiver. This is done by setting the TXEN bit of the Control Register YF2. Enabling happens immediately upon writing to the register. Disabling using TXen will occur after the completion of the transmission of the present packet; the contents of the FIFO are not cleared. Disabling will consist of stopping the transmitter clock. The Status and Interrupt Registers may still be read and the FIFO and Control Registers may be written to while the transmitter is disabled. The transmitted FCS may be inhibited using the Tcrcl bit of HDLC Master Control Register. In this mode the opening flag followed by the data and closing flag is sent and zero insertion still included, but no CRC. That is, the FCS is injected by the microprocessor as part of the data field. This is used in V.120 terminal adaptation for synchronous protocol sensitive UI frames.

8.1.9 HDLC Receiver

After initialization and enabling, the receiver clocks in serial data, continuously checking for Go-aheads (0 1111 1110), flags (0111 1110), and Idle Channel states (at least fifteen ones). When a flag is detected, the receiver synchronizes itself to the serial stream of data bits, automatically calculating the FCS. If the data length between flags after zero removal is less than 25 bits, then the packet is ignored so no bytes are loaded into Rx FIFO. When the data length after zero removal is between 25 and 31 bits, a first byte and bad FCS code are loaded into the Rx FIFO (see definition of RQ8 and RQ9 below).

If address recognition is required, the Receiver Address Recognition Registers are loaded with the desired address and the Adrec bit in the HDLC Control Register is set high(YF2). Bit 0 and 8 of the Address Register are used as enable bits for their respective byte, thus allowing either or both of the first two bytes to be compared to the expected values. Bit 0 of the first byte of the address received (address extension bit) will be monitored to determine if a single or dual byte address is being received. If this bit is 0 then a two byte address is being received and then only the first six bits of the first address byte are compared. An all call condition is also monitored for the second address byte; and if received the first address byte is ignored (not compared with mask byte). If the address extension bit is a 1 then a single byte address is being received. In this case, an all call condition is monitored for in the first byte as well as the mask byte written to the comparison register and the second byte is ignored. Seven bits of address comparison can be realized on the first byte if this is a single byte address by setting the Seven bit of HDLC control register(YF2).

The following two Status Register bits (RQ8 and RQ9) are appended to each data byte as it is written to the Rx FIFO. They indicate that a good packet has been received (good FCS and no frame abort), or a bad packet with either incorrect FCS or frame abort. The Status and Interrupt Registers should be read before reading the Rx FIFO since Status and Interrupt information correspond to the byte at the output of the FIFO (i.e. the byte about to be read). The Status Register bits are encoded as follows:

RQ9	RQ8	Byte status
1	1	last byte (bad packet)
0	1	first byte

1	0	last byte (good packet)
0	0	packet byte

The end-of-packet-detect (EOPD) interrupt indicates that the last byte written to the Rx FIFO was an EOP byte (last byte in a packet). The end-of-packet-read (EOPR) interrupt indicates that the byte about to be read from the Rx FIFO is an EOP byte (last byte in a packet). The Status Register should be read to see if the packet is good or bad before the byte is read.

A minimum size packet has an 8-bit address, an 8-bit control byte, and a 16-bit FCS pattern between the opening and closing flags. Thus, the absence of a data transmission error and a frame length of at least 32 bits results in the receiver writing a valid packet code with the EOP byte into Rx FIFO. The last 16 bits before the closing flag are regarded as the FCS pattern and will not be transferred to the receiver FIFO. Only data bytes (Address, Control, Information) are loaded into the Rx FIFO.

In the case of an Rx FIFO overflow, no clocking occurs until a new opening flag is received. In other words, the remainder of the packet is not clocked into the FIFO. Also, the top byte of the FIFO will not be written over. If the FIFO is read before the reception of the next packet then reception of that packet will occur. If two beginning of packet conditions (RQ9=0;RQ8=1) are seen in the FIFO, without an intermediate EOP status, then overflow occurred for the first packet.

The receiver may be enabled independently of the transmitter. This is done by setting the RXEN bit of HDLC Control Register. Enabling happens immediately upon writing to the register. Disabling using RXEN will occur after the present packet has been completely loaded into the FIFO. Disabling can occur during a packet if no bytes have been written to the FIFO yet. Disabling will consist of disabling the internal receive clock. The FIFO, Status, and Interrupt Registers may still be read while the receiver is disabled. Note that the receiver requires a flag before processing a frame, thus if the receiver is enabled in the middle of an incoming packet it will ignore that packet and wait for the next complete one.

The receive CRC can be monitored in the Rx CRC Register(Y1E). This register contains the actual CRC sent by the other transmitter in its original form; that is, MSB first and bits inverted. These registers are updated at each end of packet (closing flag) received and therefore should be read when an end of packet is received so that the next packet does not overwrite the registers.

9.0 MT9072 Access and Control

9.1 Processor Interface (A11-A0, D15-D0, $\overline{I/M}$, \overline{DS} , $\overline{R/W}$, \overline{CS} , \overline{IRQ} , Pins)

The control and status of the MT9072 is achieved through a non-multiplexed parallel microprocessor port capable of accommodating 12 address bits and 16 data bits. The parallel port may be configured for Motorola style control signals (by setting pin $\overline{I/M}$ low) or Intel style control signals (by setting pin $\overline{I/M}$ high).

9.1.1 Framer and Register Access

The controlling microprocessor gains access to specific registers and framers in the MT9072 through a single step process. Each of the eight internal framers is identified by the upper four address bits (A11-A8). Addresses 0XX, 1XX, 2XX... 7XX (where X indicates any hex number between 0 and F) access framers 0,1,2... 7 respectively. Address 8XX accesses all 8 framers simultaneously for processor writes. In addition, there are seven registers which are global to all eight framers; the Interrupt Vector and the Interrupt Vector Mask Registers, ST-BUS Select Register and ST-BUS analyzer control registers. These are accessed with addresses 900 to 911. Throughout this document, the upper four address bits (A11-A8) are referred to as Y, (where Y indicates any hex number between 0 and 7).

Each register in the eight internal framers is identified by the lower eight address bits (A7-A0). All registers provided in each of the eight framers are identical, with identical lower eight bit addresses. The lower eight address bits are partitioned such that the upper four bits (A7-A4) identify the register group (i.e. Control, Status, Interrupt Mask etc.) and the lower four bits (A3-A0 identify the particular register in the register group (i.e. Tx Alarm Control Word, signaling Control Word etc.), see Table 34.

Address		
A_{11}, A_{10}, A_9, A_8	A_7, A_6, A_5, A_4	A_3, A_2, A_1, A_0
Selects the framer(s) (i.e. 0, 1, 2, 3,4,5,6,7,all, global)	Selects the register group (i.e. Control, Status, Interrupt Mask etc.)	Selects the particular register in the register group (i.e. PRBS Error Counter etc.)

Table 34 - Framer and Register Access

See Figures 22 and 23 for processor timing requirements. See the Registers section for detailed register descriptions.

The MT9072 includes a status register which contains a 15 bit identification code (address 912) for the MT9072. This code identifies the marketing revision. This byte allows user software to track device revisions, and device variances and provide system variations if necessary. Refer to the registers section for details.

9.1.1.1 \overline{CS} and \overline{IRQ}

The MT9072 includes a \overline{CS} pin for applications where a single processor is controlling numerous peripherals. Processor access can be disabled without affecting framer operation. Refer to the \overline{CS} pin description for details.

An \overline{IRQ} pin is provided with an extensive suite of maskable interrupts. Refer to the \overline{IRQ} pin description and the interrupt section for interrupt processing details.

9.1.2 ST-BUS Interface (DSTi, DSTo, CSTi, CSTo Pins)

The ST-BUS is used for data and signaling access only and does not carry any MT9072 control information. Payload data is accessed through the DSTi and DSTo streams. Channel Associate Signalling bits and Common Channel Signaling bits can be accessed through CSTi and CSTo streams. See Tables 2 to 6 for ST-BUS Channel to transmit/receive timeslot mapping.

Dedicated data link pins are included which provide the user the option of bypassing the receive elastic buffer and accessing data link (DL) data with an external controller. The MT9072 provides numerous additional methods for accessing the DL, refer to the data link sections for details.

9.1.3 IMA Interface (DSTi, DSTo, Pins)

In the IMA (Inverse Mux for ATM) mode the transmit and receive timing on the backplane are independent unlike the ST-BUS where all of the streams (DSTi/DSTo) are synchronous with a single clock (CKi) and a single frame pulse (FPI). The IMA mode is specifically intended to interface to the Zarlink IMA devices such as MT90220.

In IMA mode the \overline{RXBF} and \overline{RXDLC} pins provide the receive frame pulse and receive clock for the data appearing at the DSTo pin. The FPi and CKi pins are inputs for the transmit frame pulse and transmit clock for data appearing at the DSTi pin.

Note that in the IMA Mode, the slip buffers will be bypassed. On the transmit side data is accepted in the DSTi streams with respect to the CKi clock. The transmit clock TXCL (an input clock in T1 Mode) has to be synchronous to the CKi clock. On the receive side the EXCLi clock is the master and the DSTo data is synchronous to the EXCLi clock.

In T1 IMA mode the backplane operates at 1.544 Mbit/s with the frame pulse centered on the S-Bit, the timing diagrams are shown in Figures 32 and 33. In order to provide the extracted 1.544 Mbit/s clock the E1.5CK bit in the Data Link Control Register (Y06) must be set. The receive and transmit slip buffers are bypassed in this mode.

In E1 IMA mode the backplane operates at 2.048Mbit/s in a manner similar to the ST-BUS, the timing diagrams are shown in Figures 51 and 52. The receive slip buffer is bypassed in this mode.

Note that in IMA mode the ST-BUS selection in register 900 is ignored.

If IMA mode is selected the following functions are not supported:

- 8.192 Mbits backplane mode
- Robbed bit signaling and CAS
- Digital milliwat patterns
- One, two second timers and latching of counters at 1 sec timer
- GCI mode
- Data link insertion extraction of FDL (the HDLC can be assigned to the FDL IMA mode)

Register Address	Register	Description
Y00	Framing Mode Select	Setting the IMA bit will cause the framer to enter IMA mode.
Y06	HDLC & Datalink Control	E1.5CK bit must be set to provide a 1.544 MHz clock on RXDLC.

Table 35 - Registers Related to IMA Mode

9.1.4 Signaling Multiframe Boundary ($\overline{\text{RxMF}}$, $\overline{\text{TxMF}}$ Pins)

Dedicated multiframe boundary pins are included which provide the user the option of setting the multiframe boundaries and identifying the multiframe boundaries with an external device. Refer to the $\overline{\text{RxMF}}$ and $\overline{\text{TxMF}}$ pin descriptions.

9.1.5 Control Pins

9.1.5.1 Reset Operation ($\overline{\text{RESET}}$ Pin, RST Bit and RSTC Bit)

The MT9072 can be reset using the hardware $\overline{\text{RESET}}$ pin or the software reset bits: RST (register address YF1) and RSTC (address 900). The RST bit resets a particular framer and the RSTC bit is a global software reset bit.

On initial power up, a hard reset must be done using the $\overline{\text{RESET}}$ pin. A valid reset condition requires both of these inputs to be held low for a minimum of 100ns. These inputs should be set to zero during initial power up, then set to one.

After initial power up, the MT9072 can be reset using the hardware $\overline{\text{RESET}}$ pin or the software reset bit RSTC (register address 900). When the device emerges from its reset state, it will begin to function in T1 mode and the control registers will be initialized as described in Table 36. Clearing the T1E0 bit in register 900 to place the MT9072 in E1 mode will cause another internal reset and the control registers will be initialized to their E1 defaults as described in Table 37. In addition, individual framers may be reset with the software reset bit RST. Using the RST will reset the individual framer to its default E1 or T1 setting. RST will not affect the common control register (9xx). All reset operations take 1 full frame (125 us) to complete. Refer to the $\overline{\text{RESET}}$ pin description, RSTC and RST bit descriptions for additional details.

Function	Status	Control Bits Reset Value	Register Address
Per Channel Control	Per Channel inversion, Remote timeslot loopback, local timeslot loopback, transmit test, receive test, Clear channel, Receive freeze, transmit freeze are all turned off	RPCI,MPDR,MPST,TCPI,RTSL,LTSL,TTST,RRST,MPDT,CC=0	Y90-YAF
Interrupts Masks and status Registers	All interrupts are unmasked.	Receive Sync and Alarm status & Mask, Counter statusMask, Receive Line Status Mask, Elastic store status mask and HDLC Status Mask = 0	Y43 TO Y46

Table 36 - Reset Status (T1)

Function	Status	Control Bits	Register Address
Mode	Termination	RxTRS=0, TxTRS=0	Y03
Loopbacks	Deactivated	DLBK,RLBK,SLBK,PLBK=0 RTSL(n), LTSL(n)=0	Y01 Y90-YAF
Transmit FAS	C _n 0011011	CSYN=0	Y00
Transmit non-FAS	1/S _n 1111111		Y03 Y03 Y03
Transmit MFAS (CAS)	00001111	TMA1,2,3,4=0 X1,Y,X2,X3=1	Y05 Y05
Data Link Pin	Deactivated	Sa4SS1-0,Sa5SS1-0,Sa6SS1-0,Sa7SS1-0,Sa8SS1-0=0	Y08
CRC Interworking	Activated	AUTC=0	Y00
Signaling	CAS ST-BUS Source	CSIG=0 CASS(n)=0	Y03 Y50-Y6F
ABCD Bit Debounce	Deactivated	DBNCE=0	Y05
Interrupts	All Unmasked Suspended	ALL MASK BITS =0 SPND=0, INTA=0	Y40-Y43 Y02
RxMF Output	signaling Multiframe	MFSEL=0	Y02
Error Insertion	Deactivated	E1, E2, BPVE,CRCE,FASE, NFSE,LOSE,PERR=0	Y01
Counters	Cleared	ALL BITS =0	Y15-Y1A
Counter Latches	Cleared	ALL BITS =0	Y28-Y2B
Per Timeslot Control Buffer	All locations cleared	ALL BITS =0	Y90-YAF
All Other Control Registers	All locations cleared	ALL BITS =0	All Other Control

Table 37 - Reset Status (E1)

9.1.5.2 Transmit AIS Operation ($\overline{\text{TAIS}}$ Pin)

The $\overline{\text{TAIS}}$ pin allows all eight framers of the MT9072 to transmit an all ones signal (AIS) at the TPOS and TNEG output pins from the point of power-up, without the need to write any control registers. During this time the IRQ pin is in a high impedance state. After the interface has been initialized normal operation can take place by making TAIS high.

9.1.5.3 IEEE 1149.1-1990 Test Access Port (TAP)

Five signals (TDI, TDO, TMS, TCK & $\overline{\text{TRST}}$) make up the Test Access Port (TAP) of the IEEE 1149.1-1990 Standard Test Port and Boundary-Scan Architecture. The TAP provides access to test support functions built into the MT9072. The TAP is also referred to as a JTAG (Joint Test Action Group) port. See the JTAG section for additional details.

9.1.6 Data Link (DL) Interface (RxDL, RxDL $\overline{\text{C}}$, TxDL, TxDL $\overline{\text{C}}$ Pins)

Dedicated data link pins are included which provide the user the option of bypassing the receive elastic buffer and accessing timeslot 0 data link (DL) data with an external controller. The MT9072 provides numerous additional methods for accessing the DL, refer to the DL sections for details.

9.1.7 Multiframe Boundary ($\overline{\text{RxMF}}$, $\overline{\text{TxMF}}$ Pins)

Dedicated multiframe boundary pins are included which provide the user the option of setting the multiframe boundaries and identifying the multiframe boundaries with an external device. Refer to the $\overline{\text{RxMF}}$ and $\overline{\text{TxMF}}$ pin descriptions for more details.

10.0 ST-BUS Analyzer

The ST-BUS Analyzer is a powerful system diagnostic and debugging tool. The ST-BUS Analyzer allows for the capture of any ST-BUS data stream or channel to a 32 byte memory. The ST-BUS Analyzer can capture a single frame of data or 32 samples of a specified channel from DSTi, DSTo, CSTi or CSTo from any one of the 8 framers. The analysis can be performed continuously or on a single shot basis where 32 bytes are captured and then the analysis is suspended. An optional interrupt can be generated when a single shot analysis is complete. The operation of the ST-BUS analyzer is controlled by Global Control Register 1 (901).

11.0 Loopbacks

11.1 T1 Loopbacks

In order to meet PRI Layer 1 requirements and to assist in circuit fault sectionalization, the MT9072 has 7 loopback functions.

The control bits for digital, remote, ST-BUS and payload loopbacks are located at address Y05. The remote and local timeslot loopbacks are controlled through control bits of the Timeslot Control register located at addresses Y90-YA7.

a) *Digital loopback* (DG Loop) - DSTi to DSTo at the PCM24 side. Bit DLBK = 0 normal; DLBK = 1 activate.

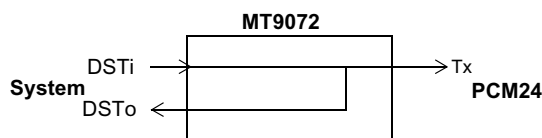

b) *Payload loopback* (PL Loop) - Payload loopback (DSTo to DSTi). Bit PLBK = 0 normal; PLBK = 1 activate. The payload loopback is effectively a physical connection of DSTo to DSTi within the framer.

Note: Set RxDO (YF1 bit 9 to 1) to obtain correct data at the Tx.

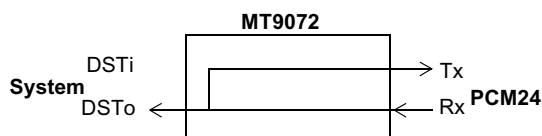

c) *Local and Remote Timeslot Loopback.* Remote timeslot loopback control bit RTSL = 0 normal; RTSL = 1 activate (Register Y90-YA7) will loop around transmit ST-BUS timeslots to the DSTo stream. Local timeslot loopback bits LTSL = 0 normal; LTSL = 1 activate(Register Y90-YA7), will loop around receive PCM24 timeslots towards the remote PCM24 end.

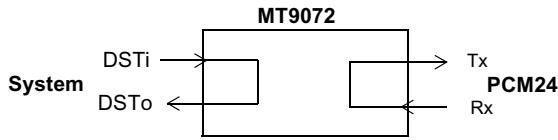

d) *Framer Remote loopback* - Internally connects RPOS and RNEG of one framer to TPOS and TNEG respectively of one of the other integrated framers.
 Bit RLBK01, RLBK23, RLBK45, RLBK67 = 0 normal; = 1 activate.

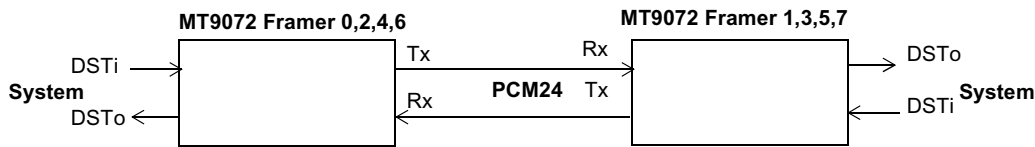

8Mbit/s mode:

Bit RLBK8 = 0 normal; = 1 activate.

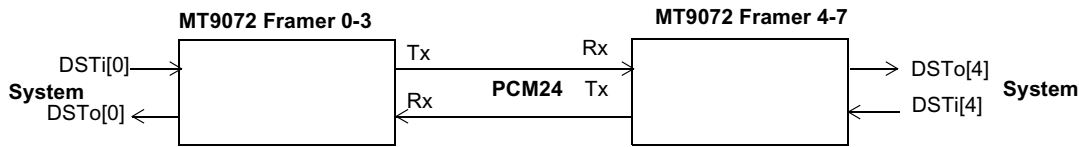

e) *Framer ST-BUS loopback(Register 904)* - Internally connects DSTi of one framer to DSTo of one of the other integrated framers.
 Bit SLBK01, SLBK23, SLBK45, SLBK67 = 0 normal; = 1 activate.

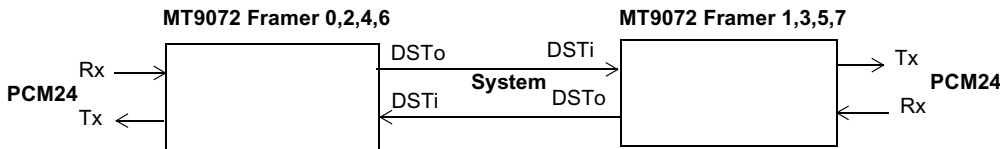

8Mbit/s mode:

Bit SLBK8 = 0 normal; = 1 activate.

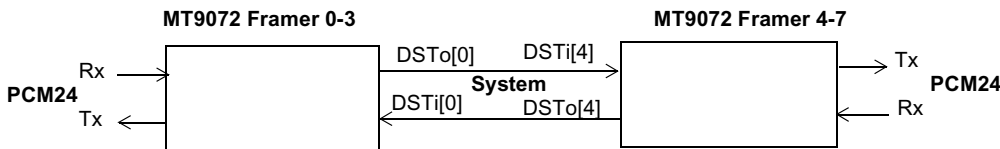

Register Address	Register	Description
Y05	Loopback Control	This register contains the loopbacks within the framer.
Y90-YAF	Per Channel Control	RTSL and LTSL are per channel loopbacks.
904	Framer Loopback Global Register	This register contains framer to framer loopbacks.

Table 38 - Registers Related to Loopbacks (T1)

11.2 T1 In Band Loopback Codes

T1.403 defines SF mode line loopback activate and deactivate codes. These codes are either a framed or unframed repeating bit sequence of 00001 for activation or 001 for deactivation. The standard goes on to say that these codes will persist for five seconds or more before the loopback action is taken. The MT9072 will detect both framed and unframed line activate and de-activate codes even in the presence of a BER of 3×10^{-3} . Line Loopback Disable Detect - LLDD - in the Alarm Status Word (Y10) will be asserted when a repeating 001 pattern (either framed or unframed) has persisted for 48 milliseconds. Line Loopback Enable Detect LLED in the Alarm Status Word will be asserted when a repeating 00001 pattern (either framed or unframed) has persisted for 48 milliseconds.

Other loopup and loopdown codes can be selected by writing to Transmit Loop Activate and Loop Deactivate Code registers(Y0D and Y0E).

The selection of the expected received loopup and loopdown code is done by writing to registers Receive Loopup Code and Receive Loop Deactivate Code Match registers(Y0F and YF0).

Interrupt status bits LLEDI and LLDDI will be set upon detection of inband loopup or loopdown codes respectively. Maskable interrupts can be generated by disabling the mask bits in Receive line status and Timer mask (Y45 bit 5).

Register Address	Register	Description
Y02	Transmit Alarm Control	If the SO bit is set, there will be framed loop codes, otherwise they will be unframed.
Y05	Loopback Control	Setting TLU or TLD will cause the transmitter to start sending the appropriate loopup and loopdown code.
Y0D	Transmit Loop Activate Code	This register contains the loop activate code which will be sent on the Tx PCM stream when TLU is set. It also contains 2 bits for code length.
Y0E	Transmit Loop Deactivate Code	This register contains the loop deactivate code which will be sent on the Tx PCM stream when TLD is set. It also contains 2 bits for code length.
Y0F	Receive Loop Activate Code Match	This register contains the loop activate code which will cause an interrupt if received on the RX PCM stream. It also contains 2 bits for code length.
YF0	Receive Loop Deactivate Code Match	This register contains the loop deactivate code which we are looking for on the RX PCM stream. It also contains 2 bits for code length.
Y10	Synchronization and Alarm Status	LLED and LLDD will be high when their respective loop codes are detected in the match registers.
Y35	Receive Line and Timer Interrupt Status	LLEI and LLDI are the interrupts for LLED and LLDD.

Table 39 - Registers Related to In Band Loopbacks (T1)

Register Address	Register	Description
Y45	Receive Line and Timer Interrupt Mask	LLEIM and LLDIM are the masks for LLEI and LLDI.

Table 39 - Registers Related to In Band Loopbacks (T1)

11.3 E1 Loopbacks

In order to meet PRI Layer 1 requirements and to assist in circuit fault sectionalization, the MT9072 has 7 loopback functions.

Table 40 specifies the registers related to controlling the different loopbacks.

Register Address	Register	Description
Y01	Test, Error and Loopback Control Register	The bits DLBK,RLBK, SLBK and PLBK can be used for digital loopback, remote loopback, ST-BUS and loopback.
Y02	Interrupt and IO control register	\overline{RxDO} and $\overline{RxC0}$ have to one for certain loopbacks to work.
Y90 to YAF	Timeslot Control Register	Local and Remote Timeslot Control Register allows for Timeslot Loopbacks (RTSLand TTSL).
904	Framer Loopback Global Register	Framer to Framer ST-BUS and Remote Loopbacks.

Table 40 - Register Related to Setting Up Loopbacks (E1)

a) *Digital loopback* (DG Loop) - DSTi to DSTo at the PCM30 side. Bit DLBK = 0 normal; DLBK = 1 activate. The control bits for digital, remote, ST-BUS and payload loopbacks are located at address Y05. The remote and local timeslot loopbacks are controlled through control bits of the Timeslot Control register located at addresses Y90-YAF.

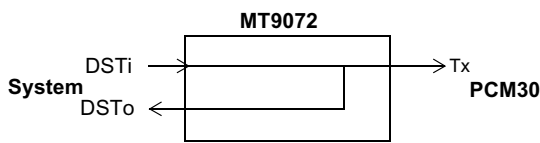

b) *Payload loopback* (PL Loop) - Payload loopback (DSTo to DSTi). Bit PLBK = 0 normal; PLBK = 1 activate. The payload loopback is effectively a physical connection of DSTo to DSTi within the MT9072.

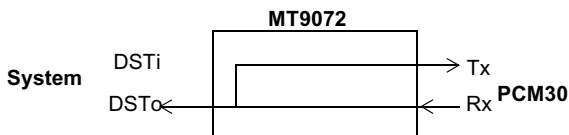

c) *Local and Remote Timeslot Loopback*. Remote timeslot loopback control bit RTSL = 0 normal; RTSL = 1 activate, will loop around transmit ST-BUS timeslots to the DSTo stream. Local timeslot loopback bits LTSL = 0 normal; LTSL = 1 activate, will loop around receive PCM30 timeslots towards the remote PCM30 end.

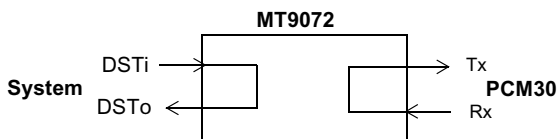

d) *Framer Remote loopback* - Internally connects RPOS and RNEG of one framer to TPOS and TNEG respectively of one of the other integrated framers.

Bit RLBK01, RLBK23, RLBK45, RLBK67 = 0 normal; = 1 activate.

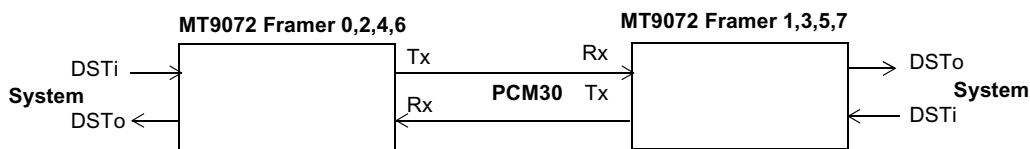

8Mbit/s mode:

Bit RLBK8 = 0 normal; = 1 activate.

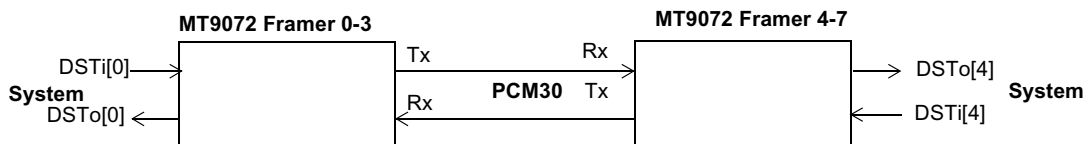

e) *Framer ST-BUS loopback* - Internally connects DSTi of one framer to DSTo of one of the other integrated framers.

Bit SLBK01, SLBK23, SLBK45, SLBK67 = 0 normal; = 1 activate.

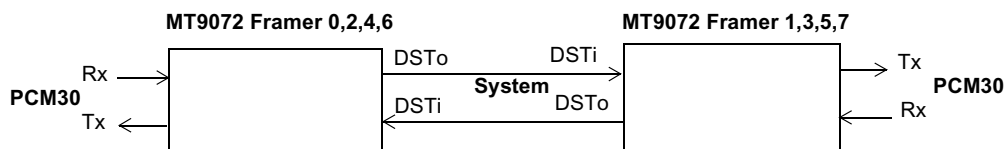

8Mbit/s mode:

Bit SLBK8 = 0 normal; = 1 activate.

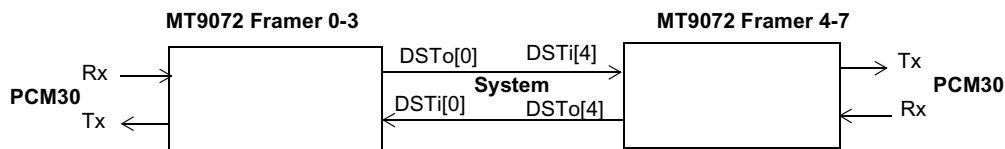

12.0 Performance Monitoring

12.1 T1 Error Counters

The MT9072 has nine error counters for each framer, which can be used for maintenance testing and ongoing measurement of the quality of a DS1 link and to assist the designer in meeting specifications such as TR62411 and T1.403. All counters can be preset or cleared by writing to the appropriate counter registers.

Associated with each counter is a maskable event occurrence interrupt and a maskable counter overflow interrupt. Overflow interrupts are useful when cumulative error counts are being recorded. For example, every time the framing bit error counter overflow interrupt (FEO) occurs, 65536 frame errors have been received since the last FEO interrupt. Also if a counter overflows, the overflow indicators are latched in the Overflow reporting latch register(Y24).

All counters are cleared by a counter clear bit -CNTCLR - low to high transition (bit 2 of the IO Control Word, YF1). An alternative approach to event reporting is to mask error events and to enable the 1 second sample bit (SAMPLE - bit 1 of the Interrupt and IO Control Word). When this bit is set the latched version of the counters(Y28 to Y2C) for change of frame alignment, loss of frame alignment, bpv errors, crc errors, errored framing bits, and multiframes out of sync are updated on one second intervals coincident with the maskable one second interrupt timer.

Counter			Interrupt Status Bits		1 Second Latch		
Description	Bits	Address	Indication	Overflow	Description	Bit	Address
PRBS Error Counter and CRC Multiframe counter for PRBS	PS7-0, PSM7-0	Y15	PRBSI	PRBSOI PRBSMFOI	NA	NA	NA
Multiframe Out of Frame Counter	MFOOF 7-0	Y16	MFOOFI	MFOOFOI	Multiframe Out of Frame Count Latch	MFOO FL15-0	Y2C
Framing Bit Error Counter	FC15-0	Y17	FBEI	FEOI	Framing Bit Error Counter Latch	FCL15- 0	Y28
BPV Counter	BPV15-0	Y18	BPVI	BPVOI	Bipolar Violation Count Latch	BPVL 15-0	Y29
CRC-6 Error counter	CC15-0	Y19	CRCI	CRCOI	CRC-6 Error Count Latch	CRCL 15-0	Y2A
Out of frame counter, change of frame alignment counter	OOF7-0, COFA7-0	Y1A	OOFI COFAI	OOFI COFOI	Out of Frame, Change of Frame Alignment Count Latch	OOFL 7-0 COFAL 7-0	Y2B
Excessive Zero counter	EXZ7-0,	Y1B	EXZI	EXZOL	NA	NA	NA

Table 41 - Error Counters Summary (T1)

12.2 E1 Error Counters

The MT9072 has eight error counters, which can be used for maintenance testing, and ongoing measurement of the quality of a PCM30 link and to assist the designer in meeting specifications such as ITU-T I.431 and G.821. All counters can be preset or cleared by writing to the appropriate locations. In addition, four error count latches are provided which latch the counter data coincident with the one second status bit. Counters can automatically be cleared (ACCLR register address Y03) after their data is latched. Associated with each counter is a maskable event indication interrupt and a maskable counter overflow interrupt. Overflow interrupts

are useful when cumulative error counts are being recorded. For example, every time the frame error counter overflow (FEO) interrupt occurs, 256 frame errors have been received since the last FEO interrupt. The interrupt status register bits are cleared when read. All non-latched error counters are cleared and by programming the counter clear bit (CNCLR register address Y03) low to high. See Table 43 for counter events and relationship between the counters.

Register Address	Register	Description
Y03	DL,CCS,CAS and other Control Register	The CNCLR bit can be used to clear the non-latched counters. the ACCLR can be used to automatically clear 1 sec counter.
Y15	PRBS Error Counter and CRC-4 Multiframe Counter	PRBS counts bit errors and the CRC counter interval for each received multiframe.
Y16	Loss of basic frame counter	Counter that is incremented once per 125 usec whenever $\overline{\text{bsync}}$ is 1.
Y17	E-bit error counter	This counter counts the ebit errors.
Y18	Bipolar violation counter. This counter counts the bipolar violation outside the HDB3 coding.	This counter counts the bipolar violation outside the HDB3 coded zeros.
Y19	CRC-4 error counter	This counter is incremented for calculated crc-4 errors (CRCS1 and CRCS2).
Y1A	FAS bit error counter and FAS error counter	This counter counts the FAS bit error and FAS errors.
Y28	E bit error counter latch	This counter is the one second latched version of Y17.
Y29	BPV error counter latch	This counter is a one second latched version of Y18.
Y2A	CRC-4 error counter latch	This counter is a one second latched version of Y19.
Y2B	FAS error counter latch	This counter is a one second latched version of Y1A.
Y36	CAS,National, CRC-4 local and timer interrupt status register	Oneseci is the one second interrupt status. This interrupt can be used for performance monitoring.
Y46	CAS,National, CRC-4 local and timer interrupt mask register	Onesecm is the one second interrupt status. This interrupt can be used for performance monitoring.

Table 42 - Registers Required for Observing and Clearing Error Counters (E1)

Counter			Source	Interrupt Status Bits		1 Second Latch		
Description	Bits	Address	Bit	Indication	Overflow	Description	Bit	Address
PRBS Error Counter	PEC7-0	Y15		PEI	PEO	NA	NA	NA
PRBS CRC-4 MF Counter	PCC7-0	Y15	CALN	NA	PCO	NA	NA	NA
Loss of Sync Counter	SLC7-0	Y16	BSYNC	BSYNC	SLO	NA	NA	NA
E-bit Error Counter	EEC15-0	Y17	REB1 REB2	E EI	EEO	E-bit Error Count Latch	EEL15-0	Y28
BPV Error Counter	VEC15-0	Y18		VEI	VEO	BPV Error Count Latch	VEL15-0	Y29
CRC-4 Error Counter	CEC15-0	Y19	CRCS1 CRCS2	CEI	CEO	CRC-4 Error Count Latch	CEL15-0	Y2A
FAS Bit Error Counter	BEC7-0	Y1A		BEI	BEO	FAS Bit Error Count Latch	BEL7-0	Y2B
FAS Error Counter	FEC7-0	Y1A		FEI	FEO	FAS Error Count Latch	FEL7-0	Y2B

Table 43 - Error Counter and Event Dependency (E1)

13.0 Maintenance and Alarms

13.1 T1 Maintenance and Alarms

13.1.1 T1 Error Insertion

Six types of error conditions can be inserted into the transmit DS1 data stream through control bits, which are located in address Y03 -Transmit Error Control Word. These error events include bipolar violation errors (BPVE), CRC-6 errors (CRCE), Ft errors (FTE), Fs errors (FSE), payload errors (PERR) and a loss of signal condition (LOSE). If LOSE is one the selected framer transmits an all zeros signal (no pulses) and zero code suppression is overridden. If LOSE bit is zero, data is transmitted normally.

13.1.2 T1 Per Timeslot Control

There are 24 per timeslot control registers occupying a total of 24 unique addresses (Y90-YA7). Each register controls a transmit timeslot and the equivalent channel data on DSTo. For example, register address Y90 of the first per timeslot control register contains program control for transmit timeslot 0 and DSTo channel 0.

13.1.3 T1 Per Timeslot Looping

Any channel or combination of channels may be looped from transmit (sourced from DSTi) to receive (output on DSTo) ST-BUS channels. When bit 4 (LTSL) in the Per Timeslot Control Word(Y90-YA7) is set the data from the equivalent transmit channel is looped back onto the equivalent receive timeslot.

Any channel or combination of channels may be looped from receive (sourced from the line data) to transmit (output onto the line) channels. When bit 5 (RTSL) in the Per Timeslot Control Word is set the data from the equivalent receive timeslot is looped back onto the equivalent transmit timeslot.

13.1.4 T1 Pseudo-Random Bit Sequence (PRBS) Testing

The MT9072 includes both a pseudo random bit sequence (PRBS) generator of type (2¹⁵-1), and a reverse PRBS generator (decoder), which operates on a bit sequence, and determines if it matches the transmitted

PRBS type ($2^{15}-1$). Bits which don't match are counted by an internal error counter. This provides for powerful system debugging and testing without additional external hardware.

If control bit ADSEQ (register address Y01) is zero, any transmit (internal DSTi) timeslot or combination of transmit timeslots may be connected to the PRBS generator. Timeslot n is selected by setting the TTSTn bit in the Timeslot n Control Register (address Y90-YA7), where n is 0 to 23. Any data sent on DSTi is overwritten on the selected timeslots before being output to TPOS/TNEG.

Similarly, if control bit ADSEQ is zero, any receive timeslot or combination of receive timeslots may be connected to the PRBS decoder. Timeslot n is selected by setting the RRSTn bit in the Timeslot n Control Register (register address Y90-YA7), where n is 0 to 23.

PRBS data is distributed to the transmit channels sequentially one byte at a time. Consequently, the data received must be in the same order that it was sent, in order for the PRBS decoder to correctly operate on the data.

If one channel is tested at a time, then the PRBS transmit timeslot does not have to match the PRBS receive timeslot. However, if more than one channel is tested, then the number of transmit timeslots must match the number of receive timeslots, and the order of the transmit timeslots must match the order of the receive timeslots. This will ensure that the sequential data bytes received by the PRBS decoder are in the correct order. Consequently, particular care must be taken when using an external loopback where the channel order may be reversed, or where the data has passed through a digital switch which doesn't buffer all channels to the same degree.

The PRBS decoder must have sufficient data pass through it before it begins to operate correctly, therefore, the errors generated by the decoder immediately following start-up should be ignored.

If the PRBS testing is performed in an external loop around using Timeslot Control, then both Timeslot Control bits TTSTn and RRSTn should also be set.

Register Address	Register	Description
Y01	Line Interface and Coding	ADSEQ bit chooses between Milliwatt test sequence and transmitted PRBS test sequence.
Y90-YA7	Per Channel Control	If TTST is set for any channel, the test sequence will be transmitted on that DS1 timeslot. If RRST is set for any channel, the test sequence will be expected on the receivePCM24 slot.
Y15	PRBS Error Counter and CRC Multiframe Counter for PRBS	The PRBS Error Counter contains error count on the received PRBS sequence.
Y34	Receive Sync Interrupt Status	PRBSOI will indicate an overflow on the PRBS Error Counter.
Y44	Receive Sync Interrupt Mask	PRBSOIM is the mask for PRBSOI.

Table 44 - Registers Related to PRBS Testing (T1)

13.1.5 T1 Mu-law Milliwatt

If the control bit ADSEQ is one (register address Y01), the Mu-law digital milliwatt sequence (Table 45) defined by G.711, is available to be transmit on any combination of selected channels. The channels are selected by setting the TTSTn control bit (register address Y90-YA7). The same sequence is available to replace received data on any combination of DSTo channels. This is accomplished by setting the RRSTn control bit (register address Y90-YA7) for the corresponding channel. Note that Bit 1 is the sign bit and is sent first.

PCM 24 Payload Data								
Hex	Bit 1	Bit 2	Bit 3	Bit 4	Bit 5	Bit 6	Bit 7	Bit 8
1E	0	0	0	1	1	1	1	0
0B	0	0	0	0	1	0	1	1
0B	0	0	0	0	1	0	1	1
1E	0	0	0	1	1	1	1	0
1E	1	0	0	1	1	1	1	0
8B	1	0	0	0	1	0	1	1
8B	1	0	0	0	1	0	1	1
9E	1	0	0	1	1	1	1	0

Table 45 - Mu Law Digital Milliwatt Pattern (T1)

13.1.6 T1 Alarms

The alarms shown in Table 46 are detected by the receiver. The status register bits provide real time status of the alarm, while the interrupt status registers bits provide latched status indications which are cleared when read. Each interrupt status register may also generate a maskable interrupt. The possible transmitted alarms are also shown in the table. See the register bit descriptions for details.

Control/Status Register			Interrupt Status Register	
Description	Bit	Address	Bit	Address
D4 Yellow Alarm. This bit is set if bit position 2 of virtually every DS0 channel is a zero for a period of 600 milliseconds. The alarm is tolerant of errors by permitting up to 16 ones in a 48 millisecond integration period. The alarm clears in 200 milliseconds after being removed from the line.	D4YALM	Y10	D4YALMI	Y35
D4 Yellow Alarm - 48 millisecond sample. This bit is set if bit position 2 of virtually every DS0 channel is a zero for a period of 48 milliseconds. The alarm is tolerant of errors by permitting up to 16 ones in the integration period. This bit is updated every 48 milliseconds.	D4Y48	Y10	D4Y48I	Y35
Secondary D4 Yellow Alarm. This bit is set if 2 consecutive '1's are received in the S-bit position of the 12th frame of the D4 superframe.	SECYEL	Y10	SECYELI	Y35
AIS Alarm. This bit is set if fewer than 5 zeros are received in a 3 millisecond window.	AIS	Y10	AISI	Y35
ESFYEL. This bit is set if the ESF yellow alarm 0000000011111111 is receive in eight or more codewords out of ten in Bit Oriented Message of FDL.	ESFYEL	Y10	ESFYELI	Y35
T1DM Received Yellow Alarm. If "Y" bit of the T1DM Synchronization Word is received	T1DRY	Y10	T1DMYI	Y35

Table 46 - Alarm Control and Status Bits (T1)

Control/Status Register			Interrupt Status Register	
Description	Bit	Address	Bit	Address
Transmit ESF Yellow Alarm. Setting this bit (while in ESF mode) causes a repeating pattern of eight 1's followed by eight 0's to be insert onto the transmit FDL.	TESFYEL	Y02	NA	NA
Transmit Secondary D4 Yellow Alarm. Setting this bit (in D4 mode) causes the S-bit of transmit frame 12 to be set.	TSECY	Y02	NA	NA
Transmit All Ones. When low, this control bit forces a framed or unframed (depending on the state of Transmit Alarm Control bit 0) all ones to be transmit at TTIP and TRING	TAIS	Y02	NA	NA
S-bit Override. If set, this bit forces the S-bits to be inserted as an overlay on any of the following alarm conditions: i) transmit all ones, ii) loop up code insertion, iii) loop down code insertion.	SO	Y02	NA	NA
TT1DMY. If reset to low a yellow alarm is sent in the 24th channel if the T1DM option is set.	TT1DMY	Y02	NA	NA

Table 46 - Alarm Control and Status Bits (T1)

13.1.7 T1 Per Timeslot Trunk Conditioning

The per channel conditioning capabilities of MT9072 are explained in this section. For the receiver the T1 data can be replaced by the conditioning data (Y09) via the bit MPDR in the per channel control registers(Y90 to YA7).

This data will be output to the corresponding DSTo channel. The received data can be inverted on a per channel basis by setting the RPCI bit (register Y90 to YA7). The transmit data can be inverted on a per channel basis with a write to the control bit TPCI (registers Y90 to YA7). The transmit data can also be frozen on a per channel basis; in this case the data from the DSTI is not used to update the Transmit Memory and the data written in Y0A is used as the source (MPDT in registers Y90 to YA7).

13.2 E1 Maintenance and Alarms

Extensive maintenance and alarm generation and detection functions are provided on the MT9072. The following table groups the registers for control and monitor of these functions.

Register Address	Register	Description
Y00	Alarm and Framing Control Register	The TAIS and E bit errors and RAI can be set by this register.
Y01	Test Error and Loopback Control Register	BPVE, CRCE,FASE, NFSE and E bit errors can be inserted.
Y05	CAS Control and Data Register	The Y bit can be used to send Remote Multiframe Alarm signal.
Y10	Synchronization and CRC-4 Remote Status	The bits of this register provide good receiver error status.
Y11	CRC-4 Timer and CRC-4 Local Status	The CRC-4 errors are registered in Y11.
Y12	Alarms and MAS Status	This register provides AIS, RAI, LOSS status bits.

Table 47 - Registers Related to Maintenance and Alarms (E1)

Register Address	Register	Description
Y24	Sync, CRC-4 remote alarm, MAS Latched Status Register	Latched version of receive CRC errors and synchronization loss are available.
Y34	Sync, CRC-4 Remote Alarm, MAS Interrupt status register	This register provides bits for interrupt generation for Y24 CRC errors and synchronization loss functions.
Y44	Sync, CRC-4 Remote Alarm, MAS Interrupt register mask	This register provides bits for interrupt mask register for Y34.

Table 47 - Registers Related to Maintenance and Alarms (E1)

13.2.1 E1 Error Insertion

Six types of error conditions can be inserted into the transmit PCM30 data stream through register control bits located at address Y01. These error events include the bipolar violation errors (BVE), CRC-4 errors (CRCE), FAS errors (FASE), NFAS errors (NFSE), payload (PERR) and a loss of signal error (LOSE). The LOSE function overrides the HDB3 encoding function (no BPV are added). Also included are E1 and E2 error bit insertion on frames 13 and 15. See the bit descriptions (control register address Y01) for additional details.

13.2.2 E1 Per Timeslot Control

There are 32 per timeslot control registers occupying a total of 32 unique addresses (Y90-YAF). Each register controls a matching timeslot on the 32 transmit channels (onto the line) and the equivalent channel data on the receive (DSTo) data. For example, register address Y91 of the first per timeslot control register contains program control for transmit timeslot 1 and DSTo channel 1.

13.2.3 E1 Per Timeslot Looping

Any channel or combination of channels may be looped from transmit (sourced from DSTi) to receive (output on DSTo) ST-BUS channels. When bit 4 (LTSL) in the Per Timeslot Control Word is set the data from the equivalent transmit timeslot is looped back onto the equivalent receive channel.

Any channel or combination of channels may be looped from receive (sourced from the line data) to transmit (output onto the line) channels. When bit 5 (RTSL) in the Per Timeslot Control Word is set the data from the equivalent receive timeslot is looped back onto the equivalent transmit channel.

13.2.4 E1 Pseudo-Random Bit Sequence (PRBS) Testing

The MT9072 includes both a pseudo random bit sequence (PRBS) generator of type $(2^{15}-1)$, and a reverse PRBS generator (decoder), which operates on a bit sequence, and determines if it matches the transmitted PRBS type $(2^{15}-1)$. Bits which don't match are counted by an internal error counter. This provides for powerful system debugging and testing without additional external hardware.

If control bit ADSEQ (register address Y01) is zero, any transmit (internal DSTi) timeslot or combination of transmit timeslots may be connected to the PRBS generator. Timeslot n is selected by setting the TTSTn bit in the Timeslot n Control Register (address Y90-YAF), where n is 0 to 31. Any data sent on DSTi is overwritten on the selected timeslots.

Similarly, if control bit ADSEQ is zero, any DSTo receive timeslot or combination of receive timeslots may be connected to the PRBS decoder. Timeslot n is selected by setting the RRSTn bit in the Timeslot n Control Register (register address Y90-YAF), where n is 0 to 31. Data on DSTo is not affected.

PRBS data is distributed to the transmit channels sequentially one byte at a time. Consequently, the data received must be in the same order that it was sent, in order for the PRBS decoder to correctly operate on the data.

The number of transmit timeslots must match the number of receive timeslots, and the order of the transmit timeslots must match the order of the receive timeslots. This will ensure that the sequential data bytes received by the PRBS decoder are in the correct order. Consequently, particular care must be taken when using an external loopback where the channel order may be reversed, or where the data has passed through a digital switch which doesn't buffer all channels to the same degree.

The PRBS decoder must have sufficient data pass through it before it begins to operate correctly, therefore, the errors generated by the decoder immediately following start-up should be ignored.

If the PRBS testing is performed in an external loop around using Timeslot Control, then both Timeslot Control bits TTSTn and RRSTn should also be set.

13.2.5 E1 A-law Milliwatt

If the control bit ADSEQ is one (register address Y01), the A-law digital milliwatt sequence (Table 48), defined by G.711, is available to be transmit on any combination of selected channels. The channels are selected by setting the TTSTn control bit (register address Y90-YAF). The same sequence is available to replace received data on any combination of DSTo channels. This is accomplished by setting the RRSTn control bit (register address Y90-YAF) for the corresponding channel. Note that bit 1 is the sign bit and is sent first.

PCM30 Payload Data								
Hex	Bit 1	Bit 2	Bit 3	Bit 4	Bit 5	Bit 6	Bit 7	Bit 8
34	0	0	1	1	0	1	0	0
21	0	0	1	0	0	0	0	1
21	0	0	1	0	0	0	0	1
34	0	0	1	1	0	1	0	0
B4	1	0	1	1	0	1	0	0
A1	1	0	1	0	0	0	0	1
A1	1	0	1	0	0	0	0	1
B4	1	0	1	1	0	1	0	0

Table 48 - A-Law Digital Milliwatt Pattern (E1)

13.2.6 E1 Alarms

The alarms shown in Table 49 are detected by the receiver. The status register bits provide real time status of the alarm, while the latched status registers provide a latched status indication, and the interrupt status registers provide a latched status indication (if unmasked) which generate a maskable interrupt and which are cleared when read. The persistent status registers provide latched status indication which is only cleared when read while the real time status bit is not set. See the register bit descriptions for additional details.

Description	Status Register		Latched Status Register		Interrupt Status Register		Persistent Status Register	
	Bit	Add.	Bit	Add.	Bit	Add.	Bit	Add.
Remote Alarm Indication	RAI	Y12	RAIL	Y24	RAII	Y34	RAIP	Y27
Alarm Indication Signal	AIS	Y12	AISL	Y24	AISI	Y34	AISP	Y27
Alarm Indication Signal 100ms	KLVE	Y12						
Channel 16 Alarm Indication Signal	AIS16	Y12	AIS16L	Y24	AIS16I	Y34		
Auxiliary Pattern	AUXP	Y12	AUXPL	Y24	AUXPI	Y34		
Loss of Signal	LOSS	Y12	LOSSL	Y24	LOSSI	Y34	LOSSP	Y27
Remote signaling Multiframe Alarm	Y	Y12	YL	Y24	YI	Y34		
T1 Timer	T1	Y11	T1L	Y26	T1I	Y36		
T2 Timer	T2	Y11	T2L	Y26	T2I	Y36		

Table 49 - Alarms and Timers Status Registers (E1)

13.2.7 E1 Automatic Alarms

The transmission of RAI and signaling multiframe alarms can be made to function automatically from control bits ARAI and AUTY (register address Y00). When ARAI = 0 and basic frame synchronization is lost (BSYNC = 1 address Y10), the MT9072 will automatically transmit the RAI alarm signal to the far end of the link. The transmission of this alarm signal will cease when basic frame alignment is acquired.

When AUTY = 0 and signaling multiframe alignment is not acquired ($\overline{\text{MSYNC}} = 1$ address Y10), the MT9072 will automatically transmit the multiframe alarm (Y-bit) signal to the far end of the link. This transmission will cease when signaling multiframe alignment is acquired.

14.0 Interrupts

The MT9072 has an extensive suite of interrupts consisting of 2 maskable interrupt vectors and 32 maskable interrupt status registers as shown in Figure 9 and an ST-BUS Analyzer Interrupt. The set bits in the 2 interrupt vectors identify which of the 32 interrupt status registers is responsible for the interrupt. Reading the corresponding interrupt status registers identifies the exact source of the interrupt. Any set bit in the interrupt vectors causes the IRQ pin to toggle low (providing the SPND bit is not set).

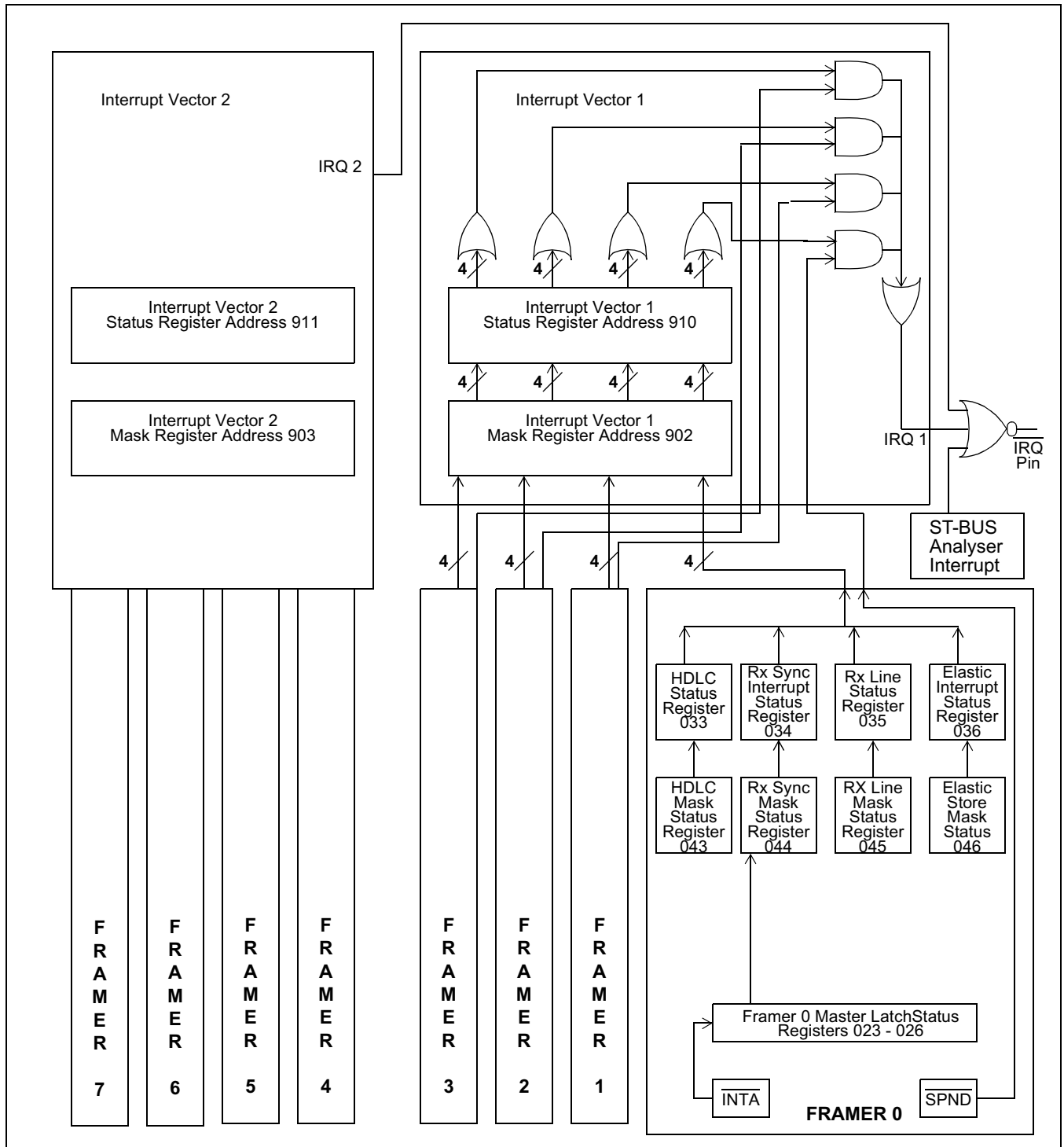

Figure 9 - Interrupt Status Registers

14.1 Interrupt Status Register Overview

All 33 interrupt status registers are maskable with 33 corresponding interrupt mask registers. All interrupt status registers and all interrupt mask registers are 16 bits, although all 16 bits are not always used. Unused status bits may be either one or zero if read.

When an unmasked interrupt occurs, one or more bits of the 33 interrupt status registers will go high causing one or more bits of the unmasked interrupt vector to go high. A high bit in the interrupt vector causes the output $\overline{\text{IRQ}}$ pin to go low (if enabled by SPND, INTA control bits). After an interrupt status register is read, it is automatically

cleared. After all interrupt status registers are cleared, the interrupt vector is cleared causing the $\overline{\text{IRQ}}$ pin to return to a high impedance state.

If a new unmasked interrupt occurs while the interrupt status registers from a previous interrupt are being read, the affected interrupt status registers will be updated, the interrupt vector will be updated, and the $\overline{\text{IRQ}}$ pin will remain low until all interrupt status registers are cleared.

If the interrupt status registers are unmasked, and the interrupt vector is masked, the interrupt status registers will function normally, but they will not cause the $\overline{\text{IRQ}}$ pin to toggle low. Only set bits in the Interrupt Vector will cause the $\overline{\text{IRQ}}$ pin to toggle low. This is similar to the $\overline{\text{SPND}}$ control bit function, but instead of masking all selected framer interrupts, the interrupt vector mask can mask individual registers within the selected framers.

14.1.1 Interrupt Related Control Bits and Pins

$\overline{\text{SPND}}$ - All interrupts for a particular framer may be suspended without changing the interrupt mask words, by setting the $\overline{\text{SPND}}$ control bit (register address YF1) to zero. All unmasked interrupt status registers will continue to be updated (and will be cleared when read), but the selected framers interrupt vector bits will remain at zero. Therefore that framer cannot toggle the $\overline{\text{IRQ}}$ pin. If all eight framer's $\overline{\text{SPND}}$ bit are zero, then all interrupt vector bits will remain low, therefore none of the framers can toggle the $\overline{\text{IRQ}}$ pin.

In some applications, a logic low at the $\overline{\text{IRQ}}$ pin lasting the full duration of the interrupt service routine may be undesirable. In these cases, immediately following the interrupt, set the control bit $\overline{\text{SPND}}$ (register address YF1) low until the interrupt service routine is finished

$\overline{\text{INTA}}$ - All interrupt and latched status registers for a particular framer may be cleared (without reading the interrupt status registers) by setting the $\overline{\text{INTA}}$ control bit (register address YF1) to zero. Interrupt status and latched registers for a particular framer will be cleared (and not updated) as long as $\overline{\text{INTA}}$ is low. Consequently, the selected framer's interrupt vector bits will remain at zero, therefore that framer cannot toggle the $\overline{\text{IRQ}}$ pin.

$\overline{\text{TAIS}}$ - During initial power up, all (8 framers) interrupt status registers are cleared without changing the interrupt mask words, when the $\overline{\text{TAIS}}$ control pin is held low. Consequently, the interrupt vector will remain clear and the $\overline{\text{IRQ}}$ pin will remain in a high impedance state. This allows for system initialization without spurious interrupts. Interrupt status registers will not be updated, and the $\overline{\text{IRQ}}$ pin will be forced to a high impedance state as long as $\overline{\text{TAIS}}$ is low.

$\overline{\text{RESET}}$ or $\overline{\text{RST}}$ - After a MT9072 reset ($\overline{\text{RESET}}$ pin for all eight framers or $\overline{\text{RST}}$ control bit (register address YF1) for a selected framer), all interrupt status register bits are unmasked, but the $\overline{\text{SPND}}$ and $\overline{\text{INTA}}$ control bits are set to zero.

14.2 Interrupt Servicing Methods

There are two common methods for identifying the source of an interrupt. The Polling Method is the simplest but uses the most processor time. The Vector Method requires a two step process, but uses the least amount of processor time.

14.2.1 Polling Method

1. The $\overline{\text{IRQ}}$ pin goes low.
2. Read all 33 interrupt vector status registers. The bits which are set in these registers identify the source of the interrupt. As each register is read, it is cleared (all bits set to 0). When all registers are clear, the interrupt is cleared (the $\overline{\text{IRQ}}$ pin returns to logic high) and all sources of the interrupt are identified.

14.2.2 Vector Method

1. The $\overline{\text{IRQ}}$ pin goes low.
2. Read the interrupt vectors. These vectors identify which of the 33 (or which combination of 33) interrupt status registers has bits which are set. Note that if multiple framers (i.e. Framer 1 and 7), or multiple conditions (i.e. Sync and Counter Overflow) caused the interrupt, more than one register may need to be read.

3. Read the interrupt status register(s) identified in step 2. The bits which are set in these registers identify the source of the interrupt. As each register is read, it is cleared (all bits set to 0). When all interrupt status registers are cleared, the interrupt vector goes to zero and the $\overline{\text{IRQ}}$ pin returns to logic high.

14.3 T1 Interrupt Vector and Interrupt Source Summary

Interrupt Vector		Interrupt Vector Mask		Interrupt Registers			
Address	Bit Name	Address	Bit Name	Status Address	Mask Address	Register Name	Framer
911	F7HVS	903	F7HM	733	743	HDLC	7
911	F7EVS	903	F7EM	734	744	Receive Sync	7
911	F7RVS	903	F7RM	735	745	Receive Line	7
911	F7SVS	903	F7SM	736	746	Elastic store	7
911	F6HVS	903	F6HM	633	643	HDLC	6
911	F6EVS	903	F6EM	634	644	Receive Sync	6
911	F6RVS	903	F6RM	635	645	Receive Line	6
911	F6SVS	903	F6SM	636	646	Elastic	6
911	F5HVS	903	F5HM	533	543	HDLC	5
911	F5EVS	903	F5EM	534	544	Receive Sync	5
911	F5RVS	903	F5RM	535	545	Receive Line	5
911	F5SVS	903	F5SM	536	546	Elastic	5
911	F4HVS	903	F4HM	433	443	HDLC	4
911	F4EVS	903	F4EM	434	444	Receive Sync	4
911	F4RVS	903	F4RM	435	445	Receive Line	4
911	F4SVS	903	F4SM	436	446	Elastic	4
911	F3HVS	902	F3HM	333	343	HDLC	3
910	F3EVS	902	F3EM	334	344	Receive Sync	3
910	F3RVS	902	F3RM	335	345	Receive Line	3
910	F3SVS	902	F3SM	336	346	Elastic store	3
910	F2HVS	902	F2HM	233	243	HDLC	2
910	F2EVS	902	F2EM	234	244	Receive Sync	2
910	F2RVS	902	F2RM	235	245	Receive Line	2
910	F2SVS	902	F2SM	236	246	Elastic	2
910	F1HVS	902	F1HM	133	143	HDLC	1
910	F1EVS	902	F1EM	134	144	Receive Sync	1
910	F1RVS	902	F1RM	135	145	Receive Line	1

Table 50 - Interrupt Vector and Interrupt Source Summary (T1)

Interrupt Vector		Interrupt Vector Mask		Interrupt Registers			
Address	Bit Name	Address	Bit Name	Status Address	Mask Address	Register Name	Framer
910	F1SVS	902	F1SM	136	146	Elastic	1
910	F0HVS	902	F0HM	033	043	HDLC	0
910	F0EVS	902	F0EM	034	044	Receive Sync	0
910	F0RVS	902	F0RM	035	045	Receive Line	0
910	F0SVS	902	F0SM	036	046	Elastic	0

Table 50 - Interrupt Vector and Interrupt Source Summary (T1)

14.4 E1 Interrupt Vector and Interrupt Source Summary

Interrupt Vector		Interrupt Vector Mask		Latch Status, Interrupt Status and Interrupt Mask Register Source				
Address	Bit Name	Address	Bit Name	Latch Address	Status Address	Mask Address	Register Name	Framer
911	F7HI	903	F7HM	723	733	743	HDLC	7
911	F7NI	903	F7NM	724	734	744	National	7
911	F7CI	903	F7CM	725	735	745	Counter	7
911	F7SI	903	F7SM	726	736	746	Sync	7
911	F6HI	903	F6HM	723	633	643	HDLC	6
911	F6NI	903	F6NM	724	634	644	National	6
911	F6CI	903	F6CM	725	635	645	Counter	6
911	F6SI	903	F6SM	726	636	646	Sync	6
911	F5HI	903	F5HM	523	533	543	HDLC	5
911	F5NI	903	F5NM	524	534	544	National	5
911	F5CI	903	F5CM	525	535	545	Counter	5
911	F5SI	903	F5SM	526	536	546	Sync	5
911	F4HI	903	F4HM	423	433	443	HDLC	4
911	F4NI	903	F4NM	424	434	444	National	4
911	F4CI	903	F4CM	425	435	445	Counter	4
911	F4SI	903	F4SM	426	436	446	Sync	4
910	F3HI	902	F3HM	323	333	343	HDLC	3
910	F3NI	902	F3NM	324	334	344	National	3
910	F3CI	902	F3CM	325	335	345	Counter	3
910	F3SI	902	F3SM	326	336	346	Sync	3

Table 51 - Interrupt Vector and Interrupt Source Summary (E1)

Interrupt Vector		Interrupt Vector Mask		Latch Status, Interrupt Status and Interrupt Mask Register Source				
Address	Bit Name	Address	Bit Name	Latch Address	Status Address	Mask Address	Register Name	Framer
910	F2HI	902	F2HM	223	233	243	HDLC	2
910	F2NI	902	F2NM	224	234	244	National	2
910	F2CI	902	F2CM	225	235	245	Counter	2
910	F2SI	902	F2SM	226	236	246	Sync	2
910	F1HI	902	F1HM	123	133	143	HDLC	1
910	F1NI	902	F1NM	124	134	144	National	1
910	F1CI	902	F1CM	125	135	145	Counter	1
910	F1SI	902	F1SM	126	136	146	Sync	1
910	F0HI	902	F0HM	023	033	043	HDLC	0
910	F0NI	902	F0NM	024	034	044	National	0
910	F0CI	902	F0CM	025	035	045	Counter	0
910	F0SI	902	F0SM	026	036	046	Sync	0

Table 51 - Interrupt Vector and Interrupt Source Summary (E1)

14.5 E1 Interrupt Source and Interrupt Status Register Summary

Real Time Source Status Register or PCM30		Interrupt Status Register			Interrupt Description
Address	Bit Name	Address	Bit Name		
Y10	RCRCR	Y34	RCRCRI	S Y N C	remote CRC-4 and RAI occurred
Y10	RSLP	Y34	RSLPI		receive slip occurred
Y12	Y	Y34	YI		remote multiframe sync fail occurred
Y12	AUXP	Y34	AUXPI		auxiliary pattern occurred
Y12	RAI	Y34	RAII		remote alarm occurred
Y12	AIS	Y34	AISI		alarm indication signal occurred
Y12	AIS16	Y34	AIS16I		alarm indication signal on channel 16 occurred
Y12	LOSS	Y34	LOSSI		loss of signal occurred
Y10	RCRC0	Y34	RCRC0I		remote CRC-4 sync and RAI for 10ms and up occurred
Y10	RCRC1	Y34	RCRC1I		remote CRC-4 sync and RAI for 10ms to 450ms occurred
Y10	CEFS	Y34	CEFSI		consecutive errored FAS's occurred
Y10	RFAIL	Y34	RFAILI		remote CRC-4 multiframe generator/detector failure occurred
Y10	CSYNC	Y34	CSYNCI		loss of CRC-4 sync occurred
Y10	MSYNC	Y34	MSYNCI		loss of multiframe sync occurred
Y10	BSYNC	Y34	BSYNCI		loss of basic frame sync occurred
Y16	SL15-0	Y35	SLOI		C O U N T E R
Y1A	FEC7-0	Y35	FEOI	frame alignment signal (FAS) error counter overflowed	
Y1A	FEC7-0	Y35	FEII	frame alignment signal (FAS) error occurred	
Y1A	BEC7-0	Y35	BEOI	frame alignment signal (FAS) bit error counter overflowed	
Y1A	BEC7-0	Y35	BEII	frame alignment signal (FAS) bit error occurred	
Y19	CEC15-0	Y35	CEOI	CRC-4 error counter overflowed	
Y19	CEC15-0	Y35	CEII	CRC-4 error occurred	
Y18	VEC15-0	Y35	VEOI	bipolar violation error counter overflowed	
Y18	VEC15-0	Y35	VEII	bipolar violation error occurred	
Y17	EEC15-0	Y35	EEOI	E-bit error counter overflowed	
Y17	EEC15-0	Y35	EEII	E-bit error occurred	
Y15	PCC7-0	Y35	PCOI	PRBS CRC-4 multiframe counter overflowed	
Y15	PEC7-0	Y35	PEOI	PRBS error counter overflowed	
Y15	PEC7-0	Y35	PEII	PRBS error occurred	

Table 52 - Interrupt Source & Status Register Summary (E1)

Real Time Source Status Register or PCM30		Interrupt Status Register			Interrupt Description
Address	Bit Name	Address	Bit Name		
PCM30	Sa5	Y36	Sa5VI	N A T I O N A L	Sa5 bit value was one when Sa6N8 toggled from zero to one
PCM30	Sa6	Y36	Sa6V3I		Sa6 bit 3 value was one when Sa6N8 toggled from zero to one
PCM30	Sa6	Y36	Sa6V2I		Sa6 bit 2 value was one when Sa6N8 toggled from zero to one
PCM30	Sa6	Y36	Sa6V1I		Sa6 bit 1 value was one when Sa6N8 toggled from zero to one
PCM30	Sa6	Y36	Sa6V0I		Sa6 bit 0 value was one when Sa6N8 toggled from zero to one
PCM30	Sa6	Y36	Sa6N8I		sequence of 8 identical Sa6 nibbles occurred
PCM30	Sa6	Y36	Sa6NI		Sa6 nibble changed
PCM30	Sa5-8	Y36	SaNI		Sa5,6,7 or 8 nibble changed
PCM30	Sa5	Y36	Sa5TI		Sa5 bit changed
PCM30	Sa5-8	Y36	SaTI		Sa5,6,7 or 8 bits changed
Y70-Y8F	ABCD	Y36	CASRI		receive CAS bit (ABCD) changed
Y11	CALN	Y36	CALNI		CRC-4 2ms timer toggled
Y11	T2	Y36	T2I		CRC-4 10ms timer toggled from zero to one
Y11	T1	Y36	T1I		CRC-4 100ms timer toggled from zero to one
		Y36	ONESECI		1s timer toggled from zero to one

Table 52 - Interrupt Source & Status Register Summary (E1)

15.0 JTAG (Joint Test Action Group) Operation

The MT9072 JTAG (Joint Test Action Group) interface conforms to the Boundary-Scan standard IEEE1149.1-1990. This standard specifies a design-for-testability technique called Boundary-Scan test (BST). Figure 10 shows the BST architecture which is made up of the following four basic elements. See Figure 70 for JTAG timing.

1. Test Access Port (TAP)
2. TAP Controller
3. Instruction Register (IR)
4. Test Data Registers (TDR)

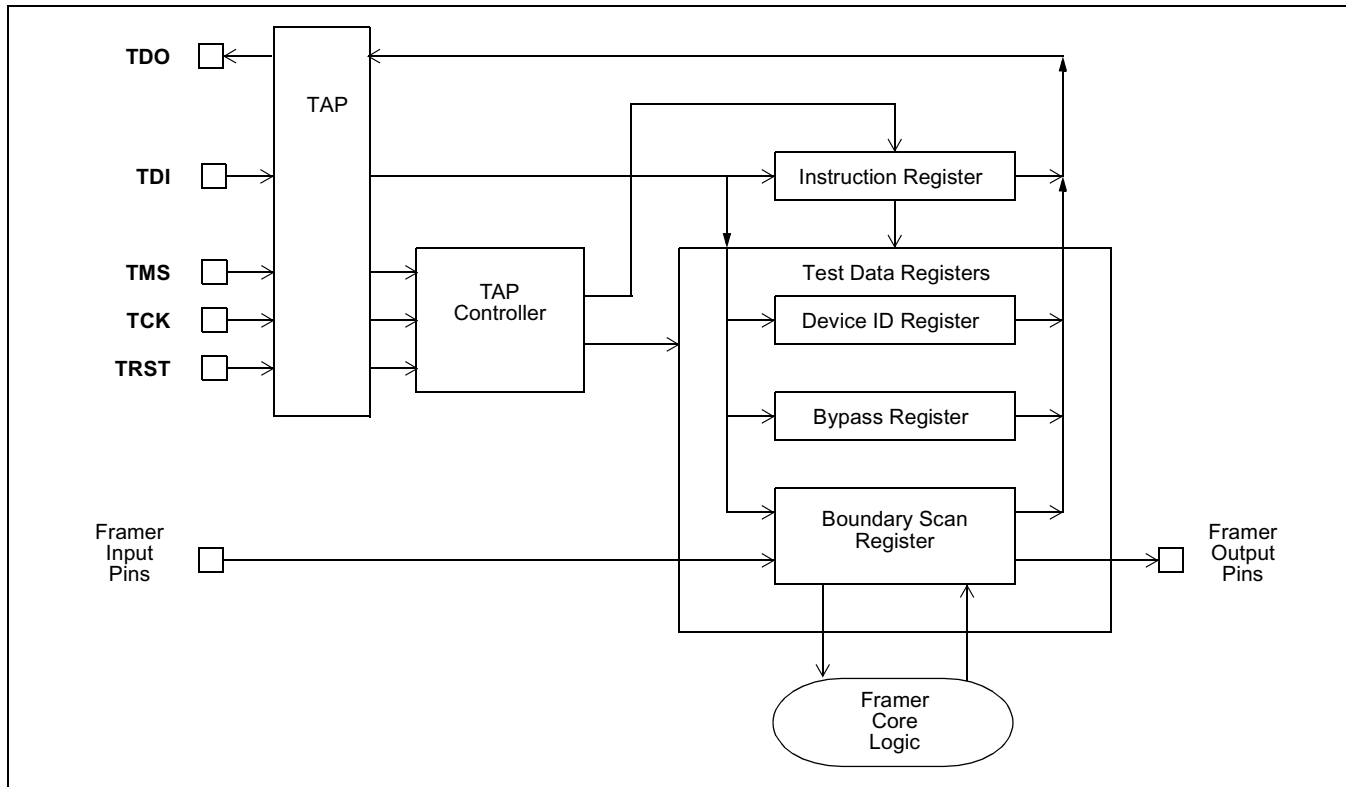

Figure 10 - Boundary Scan Test Circuit Block Diagram

15.1 Test Access Port (TAP)

The Test Access Port (TAP) provides access to the many test functions of the MT9072. It consists of four input pins and one output pin. The following pins are from the TAP.

Test Clock Input (TCK) - TCK provides the clock for the test logic. The TCK signal does not interfere with any on-chip clocks and thus remains independent. The TCK permits shifting of test data into or out of the Boundary-Scan register cells concurrently with the operation of the device and without interfering with the on-chip logic.

Test Mode Select Input (TMS) - The logic signals received at the TMS input are interpreted by the TAP Controller to control the test operations. The TMS signal is sampled at the rising edge of the TCK pulses. This pin is internally pulled up to device V_{DD} when it is not driven from an external source.

Test Data Input (TDI) - Serial input data applied to this port is fed either into the instruction register or into a test data register, depending on the sequence previously applied to the TMS input. Both registers are described in a subsequent section. The received input data is sampled at the rising edge of TCK pulses. This pin is internally pulled up to device V_{DD} when it is not driven from an external source.

Test Data Output (TDO) - Depending on the sequence previously applied to the TMS input, the contents of either the instruction register or data register are serially shifted out towards the TDO pin. The data out of TDO is clocked on the falling edge of the TCK pulses. When no data is shifted through the boundary scan cells, the TDO driver is set to a high impedance state.

Test Reset (\overline{TRST}) - Reset the JTAG scan structure.

15.2 Test Access Port (TAP) Controller

The TAP Controller generates clock and control signals for the Instruction Register (IR) and the Test Data Registers (TDR's). The TAP Controller operates synchronously with the TCK input clock and responds to the TMS input signal to generate control signals which shift, capture, or update data through either the IR or the TDR's.

15.3 Instruction Register

The Instruction Register (IR) is a 3-bit register which allows one of four test instructions to be shifted into the device. Test instructions are serially loaded into the IR from the TDI pin by the TAP Controller. Refer to Table 53 which describes the test instructions provided by the MT9072; these instructions are in accordance with the IEEE 1149.1 standard.

MSB		LSB		Instruction Name	Functional Description
0	0	0	0	EXTEST	This instruction isolates the framer logic (on chip logic) from the input and output pins. The signal states at the output pins are determined by the values programmed (earlier) in the Boundary Scan Register. This instruction allows testing of board level interconnects (i.e. open, stuck at, bridge).
0	1	0	0	SAMPLE/ PRELOAD	This instruction performs two functions. On the rising edge of TCK, the SAMPLE instruction is performed. With this instruction, the signal states at the input and output pins are loaded into the Boundary Scan Register. On the falling edge of TCK, the PRELOAD instruction is performed. With this instruction, the signal states at the output pins is determined by the values programmed (earlier) in the Boundary Scan Register.
0	0	1	1	IDCODE	This instruction forces the value of the 32 bit MT9072 Identification Register into the Instruction Register's parallel output latches. This is the default instruction loaded after a JTAG reset.
1	1	1	1	BYPASS	This instruction connects the Bypass Register between the TDI and TDO pins.
Note 1. The following optional JTAG instructions are not supported, INTEST, RUNBIST and USERCODE.					

Table 53 - JTAG Instruction Register

15.4 JTAG Data Registers

As specified in IEEE 1149.1, the JTAG Interface must contain as a minimum the boundary scan register and the bypass register. The device identification register although optional, is also included in the MT9072.

15.4.1 Identification Register

This is a 32 bit register as defined in Table 54. Note that the part number revision is not the same as the silicon revision which is not supplied.

Version	Part Number	Manufacturer Identity	LSB=1
(4 bits)	(16 bits)	(11 bits)	(1 bit)
A	9072	Zarlink	LSB=1
0000	1001 0000 0111 0010	0001 0100 101	1
0	9 0 7 2	14B	
0 9 0 7 2 1 4 B			

Table 54 - JTAG MT9072 Identification Register

15.4.2 The Bypass Register

The Bypass Register is a single stage shift register that provides a one-bit path from TDI to TDO.

The Boundary-Scan Register (BSR) provides an interface between the MT9072 core logic and the MT9072 input and output pins. This interface is controlled by the TAP Controller and Instruction Register. The BSR provides status of all input, output and bi-directional pins and control over all output and bi-directional pins. The BSR maps to 192 pins. Each input pin maps to one BSR bit (input cell), each output pin maps to one or two BSR bits (output and enable cells), and each bi-directional pin maps to three BSR bits (input, output and enable cells). Bit 0 of the BSR is the last bit in the JTAG chain and the first bit clocked out. The JTAG chain starts at RPOS[0] and moves counterclockwise around the chip finishing at the T1 pin. See Table 55 for additional details.

Device Pin			Boundary-Scan Register Bits (0 to 245)		
Name	Type	Cell #	Enable Cell	Output Cell	Input Cell
			When this control/status bit is one, the corresponding pin is in a high impedance state. When zero, the corresponding pin operates normally.	When this control/status bit is one, the corresponding pin is high. When zero, the corresponding pin is low.	When this status bit is one, the corresponding pin is high. When zero, the corresponding pin is low.
T1	input	0	NA	NA	0
T3	input	1	NA	NA	1
This sequence continues around the chip. Refer to the BSDL file for BSR bit mapping.					
IRQ	output	6	NA	6	NA
R/W	input	7	NA	NA	7
This sequence continues around the chip. Refer to the BSDL file for BSR bit mapping.					
D15	bi-directional	22-24	22	23	24
D14	bi-directional	25-27	25	26	27
This sequence continues around the chip. Refer to the BSDL file for BSR bit mapping.					
CSTo[0]	output	227-228	227	228	NA
This sequence continues around the chip. Refer to the BSDL file for BSR bit mapping.					
TPOS[0]	output	242	NA	242	NA
EXCLi[0]	input	243	NA	NA	243
RNEG[0]	output	244	NA	NA	244
RPOS[0]	input	245	NA	NA	245

Table 55 - JTAG Boundary-Scan Register

15.5 Boundary Scan Description Language (BSDL) File

A Boundary Scan Description Language (BSDL) file is available for the MT9072 JTAG implementation. This ASCII (text) file provides all the information required for a JTAG test system to access the MT9072's boundary scan circuitry.

16.0 MT9072 Register Set

16.1 T1 Register Set

16.1.1 Register Address (000 - FFF) Summaries

16.1.1.1 Framer Address (0XX-9XX) Summary

Binary Address (A11-A0)	Hex Address	Framer Accessed
000 xxxx xxxx	0XX	0
001 xxxx xxxx	1XX	1
010 xxxx xxxx	2XX	2
011 xxxx xxxx	3XX	3
100 xxxx xxxx	4XX	4
101 xxxx xxxx	5XX	5
110 xxxx xxxx	6XX	6
111 xxxx xxxx	7XX	7
1000 xxxx xxxx	8XX	0,1,2...7(reserved for writes only)
1001 0000 xxxx	90X	Global control Registers for the MT9072
1001 0001 xxxx	91X	Global status Registers for the MT9072
1001 0010 xxxx	92X	ST-BUS analyser buffer data
1001 0011 xxxx	93X	ST-BUS analyser buffer data
xxxx indicates all (0000 to 1111) binary possibilities X indicates all (0 to F) hex possibilities		

Table 56 - Framer Addressing (0XX - 9XX) (T1)

16.1.1.2 Register Group Address (Y00 - YFF) Summary

Binary Address (A11-A0)	Hex Address	Register Group Accessed	Processor Access	ST-BUS Access
yyyy 0000 xxxx yyyy1111 xxxx	Y0X YFX	Master Control	R/W	---
yyyy 0001 xxxx	Y1X	Master Status	R	---
yyyy 0010 xxxx	Y2X	Latched Status	R	---
yyyy 0011 xxxx	Y3X	Interrupt Status	R	---
yyyy 0100 xxxx	Y4X	Interrupt Mask	R/W	---
yyyy 0101 xxxx yyyy 0110 xxxx	Y5X-Y6X	Per Channel Tx signaling	R/W	yes
yyyy 111 xxxx yyyy 1000 xxxx	Y7X-Y8X	Per Channel Receive signaling	R/W	yes
yyyy 1001 xxxx yyyy 1010 xxxx	Y9X-YAX	Per Channel Control	R/W	---
yyyy 1011 xxxx yyyy 1100 xxxx	YBX-YCX	not used		
yyyy 1101 xxxx yyyy 1110 xxxx	YDX-YEX	not used		

xxxx indicates all (0000 to 1111) binary possibilities
 X indicates all (0 to F) hex possibilities
 yyyy indicates 9 (000, 001, 010, 011, 111,1000,1001) binary possibilities representing 1 of 8 framers (R/W), and all 8 framers (W only) and global selection.
 Y indicates 9 (0,1,2,3,4...9) hex possibilities representing 1 of 8 framers (R/W), and all 8 framers (W only), and global selection.

Table 57 - Register Group Address (Y00 - YFF) Summary (T1)

16.1.1.3 Global Control and Status Register (900-91F) Summary

Binary Address (A ₁₁ -A ₀)	Hex Address	R/W	Register	Control Bits (B ₁₅ - B ₈ / B ₇ - B ₀)
1001 0000 0000	900	R/W	Global Control0	T1Eo, $\overline{\text{STBUS}}$,##,##,##,##,##,##,##,##,CK1,##,##,RSTC
1001 0000 0001	901	R/W	Global Control1	CHANNUM(4:0),STRNUM(4:0),STBUFEN,FRNUM(2:0),CHUP,CONTSIN
1001 0000 0010	902	R/W	Interrupt Vector Mask Register	F3HM,F3EM, F3RM, F3SM,F2HM, F2EM, F2RM, F2SM, F1HM,F1EM, F1RM, F1SM,F0HM, F0EM, F0RM, F0SM
1001 0000 0011	903	R/W	Interrupt Vector Mask Register	F7HM,F7EM, F7RM, F7SM,F6HM, F6EM, F6RM, F6SM, F5HM,F5EM, F5RM, F5SM,F4HM, F4EM, F4RM, F4SM
1001 0000 0100	904	R/W	Framer Loopback Global Register	SLBK8, SLBK67, SLBK45, SLBK23, SLBK01,RLBK8, RLBK67, RLBK45, RLBK23, RLBK01,##,##,##,##,##
1001 0000 0101	905	R/W	Framer 0 ST-Bus Analyser Interrupt Mask Register	##,##,##,##,##,##,##,##,##,##,##,##,##,STM
1001 0000 0110-1001 0000 1111	906-90F	R/W	not used	not used
1001 0001 0000	910	R	Interrupt Vector Status 0	F3HVS,F3EVS, F3RVS, F3SVS,F2HVS, F2EVS, F2RVS, F2SVS, F1HVS,F1EVS, F1RVS, F1SVS,F0HVS, F0EVS, F0RVS F0SVS
1001 0001 0001	911	R	Interrupt Vector Status1	F7HVS,F7EVS, F7RVS, F7SVS,F6HVS, F6EVS, F6RVS, F6SVS, F5HVS,F5EVS, F5RVS, F5SVS,F4HVS, F4EVS, F4RVS F4SVS
1001 0001 0010	912	R	Identification Code Status	ID15-0
1001 0001 0011	913	R	ST-Bus Analyser Interrupt Vector Register	##,##,##,##,##,##,##,##,##,##,##,##,##,STIS
1001 0001 0100-1001 0001 1111	914-91F		not used	
1001 0010 0010 1001 0011 1111	920-93F	R	ST-Bus Analyser Data	##,##,##,##,##,##,STAD(7:0)
1001 0100 0100 1001 1111 1111	940-9FF		not used	

indicates unused bits in register that may be any value if read

Table 58 - Global Control and Status (900 - 91F) Summary (T1)

Binary Address (A11-A0)	Hex Address	R/W	Register	Control Bits (B15 - B8 / B7 - B0)
yyyy 1111 0101	YF5	R/W	TX FIFO	###,###,###,###, TXFIFO7-0
yyyy 1111 0110	YF6	R/W	TX Byte count	###,###,###,###, CNT7-0
yyyy 1111 0111	YF7	R/W	Transmit Set Delay Bits 7 - 0.	###,###,###,###, TXSD7-0
yyyy 1111 1000 yyyy1111 1111	YF8- YFF		not used	not used
<p>xxxx indicates all (0000 to 1111) binary possibilities X indicates all (0 to F) hex possibilities yyyy indicates 9 (000, 001, 010, 011, 111,1000,1001) binary possibilities representing 1 of 8 framers (R/W), all 8 framers (W only), and global selection. Y indicates 9 (0,1,2,3,4...9) hex possibilities representing 1 of 8 framers (R/W), and all 8 framers (W only) and global selection(R/W)</p>				

Table 59 - Master Control Registers Address (Y00 to Y0F and YF0 to YFF) Summary (T1)

16.1.1.6 Latched Status Registers Address (Y20-Y2F) Summary

Binary Address (A11-A0)	Hex Address	R/W	Latched Status Register	Status Bits (B15 - B8 / B7 - B0)
yyyy 0010 0000- yyyy 0010 0010	Y20-Y22	-	not used	not used
yyyy 0010 0011	Y23	R	HDLC Status Latch	###,###,###,###,###,###, GAL, EOPDL, TEOPL, EOPRL, TXFLL, FAL, TXUNDERL, RXFFL, RXOVFLL
yyyy 0010 0100	Y24	R	Receive Sync and Alarm Latch	FEOL, CRCOL, OOFOL, COFAOL, BPVOL, PRBSOL, PRBSMFOL, MFOOFOL, TFSYNL, MFSYNL, FBEL, COFAL, SEFL, AISL, CRCL, LOSL
yyyy 0010 0101	Y25	R	Receive Line status and Time Latch	D4YALML, D4Y48L, SECYELL, ESFYELL, T1DMYL, #, BPVL, PRBSL, PDVL, LLEDL, LLDDL, RXBOML, RXBOMML, CASRL, 1SECL, 2SECL
yyyy 0010 0110	Y26	R	Elastic Store and Excessive zero Latch	###,###,###,###,###,###,###,###,###,###, EXZOL, EXZL, TXSLIPL, RXSLIPL
yyyy 0010 0111	Y27	R	not used	
yyyy 0010 1000	Y28	R	Framing Bit Error Counter Latch	FCL<15:0>
yyyy 0010 1001	Y29	R	Bipolar Violation Error Counter Latch	BPVL<15:0>
yyyy 0010 1010	Y2A	R	CRC-6 Error Counter Latch	CRCL<15:0>
yyyy 0010 1011	Y2B	R	Out of Frame and Change of Frame Count Latch	OOFL<7:0>, COFAL<7:0>
yyyy 0010 1100	Y2C	R	Multiframe Out of Frame Count Latch	MFOOFL<15:0>
yyyy 0010 1101 yyyy 0010 1111	Y2D- Y2F		not used	

xxxx indicates all (0000 to 1111) binary possibilities

X indicates all (0 to F) hex possibilities

yyyy indicates 9 (000, 001, 010, 011, 111, 1000, 1001) binary possibilities representing 1 of 8 framers (R/W), all 8 framers (W only) and global selection.

Y indicates 9 (0, 1, 2, 3, 4...9) hex possibilities representing 1 of 8 framers (R/W), and all 8 framers (W only) and global selection.

Table 61 - Latched Status Register (R) Address (Y2X) Summary (T1)

16.1.1.8 Interrupt Mask Registers Address (Y40-Y4F) Summary

Binary Address (A11-A0)	Hex Address	R/W	Interrupt Mask Register	Control Bits (B15 - B8 / B7 - B0)
yyyy 0010 0000- yyyy 0010 0010	Y40-Y42	-	not used	not used
yyyy 0100 0011	Y43	R	HDLC Interrupt Mask	###,###,###,GAIM,EOPDIM,TEOPIM,EOPRIM, TXFLIM,FAIM,TXUNDERIM,RXFFIM,RXOVFLIM
yyyy 0100 0100	Y44	R	Receive Sync and Alarm Interrupt Mask	FEOIM,CRCOIM,OOFOIM,COFAOIM,BPVOIM, PRBSOIM,PRBSMFOIM,MFOOFOIM,TFSYNIM, MFSYNIM,FBEIM,COFAIM,SEFIM,AISIM,CRCIM, LOSIM
yyyy 0100 0101	Y45	R	Receive Line status and Timer Interrupt Mask	D4YALMIM,D4Y48IM,SECYELIM,ESFYELIM, T1DMYIM,#,BPVIM,PRBSIM,PDVIM,LLEDIM, LLDDIM,BIOMIM,BOMMIM,CASRIM,1SECIM,2SE CIM
yyyy 0100 0110	Y46	R	Elastic Store and Excessive Zero Interrupt Mask	###,###,###,###,###,EXZOIM,EXZIM,TXSLIPIM, RXSLIPIM
yyyy 0100 0111 yyyy 0100 1111	Y47-Y4F	R	not used	not used
xxxx indicates all (0000 to 1111) binary possibilities X indicates all (0 to F) hex possibilities yyyy indicates 9 (000, 001, 010, 011, 111,1000,1001) binary possibilities representing 1 of 8 framers (R/W), and all 8 framers (W only) and global selection. Y indicates 9 (0,1,2,3,4...9) hex possibilities representing 1 of 8 framers (R/W), and all 8 framers (W only) and global selection.				

Table 63 - Interrupt Mask Register (R/W) Address (Y4X) Summary (T1)

16.1.2 Master Control Registers (Y00 to YF0) Bit Functions

Tables 64 to 79 describe the bit functions of each of the Master Control Registers in the MT9072. Each register is repeated for each of the 8 framers. Framer 0 is addressed with Y=0, Framer 1 with Y=1, Framer 2 with Y=2,... Framer 7 with Y=7 (where Y represents the 4 most significant address bits (MSB) A₁₁ A₁₀ A₉ A₈). In addition, a simultaneous write to all 8 Framers is possible by setting the address A11 to 1 and A10 to A8 to 0. A (0), (1) or (#) in the "Name" column of these tables indicates the state of the data bits after a hard reset (the RESET pin is toggled from zero to one), or a software reset (the RST bit in control register address YF1 is toggled from one to zero or toggling of RSTC in Global Control Register). The (#) indicates that a (0) or (1) is possible.

Bit	Name	Functional Description
15	IMA (0)	Inverse Mux for ATM Mode. Setting this bit high allows the IO port to be easily connected to one of the Zarlink IMA devices such as MT90220. DSTi becomes a serial 1.544 Mb/s data stream. C4b becomes a 1.544 MHz clock that clocks DSTi in on the falling edge. RXFPB becomes a positive framing pulse that is high for the first bit of the serial T1 stream coming from the DSTo pin. The data from DSTo is clocked out on the rising edge of RXDLC. Set this pin low for all other applications. Note that signaling operations CSTi/CSTo do not function in the IMA Mode. The Global Control Register 900 bit CK1 is ignored for this mode. 8.192 Mbit/s backplane mode is not supported if IMA mode is selected on any of the framer's.
14	#	not used.
13	G.802 (0)	G802 Mode. If set, this bit maps DSTi data channels transparently onto the transmit line data and maps the receive data onto DSTo channels as per G.802.
12	JYEL (0)	Japan Yellow Alarm Set this bit high to select a pattern of 16 ones (1111111111111111) as the ESF yellow alarm. In order to transmit the japan yellow alarm the TESHYEL bit has to be set.
11	TRANSP (0)	Transparent Mode Select. In transparent Mode the data present at the DSTi channels are transparently sent to the T1 interface. The S bit from the DSTi interface (Channel 31 if running at 2.048 Mb/s backplane) is sent to the S bit position of the T1 interface. The rest of the channelized data is sent unaltered to the T1 interface. Ensure that TCPI of per channel controlis not set.
10	T1DM (0)	T1DM Mode Select. Set this bit high to select T1DM Mode. In T1DM the Ft and Fs pattern is the same as the D4 Mode but a 1011YR0 pattern is sent and detected in Channel 24 of the T1 interface. Bit Y is used to indicate a yellow Alarm and R bit is used by AT&T for a 8 Kb/s communication channel.
9	ESF (0)	Extended Super Frame. Setting this bit enables transmission and reception of the 24 frame superframe DS1 protocol.
8	(0)	not used.
7	CXC (0)	Cross Check. Setting this bit in ESF mode enables a cross check of the CRC-6 remainder before the frame synchronizer pulls into sync. This process adds at least 6 milliseconds to the frame synchronization time.
6-5	RS1-0 (00)	Reframe Select 1 - 0. These bits set the criteria for an automatic reframe in the event of framing bits errors. The combinations available are: RS1 - 0, RS0 - 0 = sliding window of 2 errors out of 4 frames. RS1 - 0, RS0 - 1 = sliding window of 2 errors out of 5 frames. RS1 - 1, RS0 - 0 = sliding window of 2 errors out of 6 frames. RS1 - 1, RS0 - 1 = no reframes due to framing bit errors. Note that for T1DM mode, the definition of frame boundary is starting from the channel 1 data including the synchronization byte(10111YR0) and the following ' S ' bit. The Y and the R bits are ignored for synchronization.

Table 64 - Framing Mode Select (R/W Address Y00) (T1)

Bit	Name	Functional Description
4	FSI (0)	Fs Bit Include. Only applicable in D4 mode. Setting this bit causes errored Fs bits to be included as framing bit errors. A bad Fs bit will increment the Framing Error Bit Counter, and will potentially cause a reframe. The Fs bit of the receive frame 12 will only be included if D4SECY is set. Note that when FSI bit is set both Ft and Fs are taken into consideration before declaration of synchronization
3	REFR (0)	Reframe. A 0 to 1 transition of this bit causes an automatic reframe.
2	MFREFR (0)	MultiFrame Reframe. Only applicable in D4 mode. Setting this bit causes an automatic multiframe reframe. The signaling bits are frozen until multiframe synchronization is achieved. Terminal frame synchronization is not affected.
1	JTS (0)	Japan Telecom Synchronization. If this bit is set, the S-bit is included in the CRC6 calculation for the ESF framing Mode.
0	TxSYNC (0)	Transmit Synchronization. Setting this bit causes the transmit multiframe boundary to be internally synchronized to the incoming S-bits on DSTi channel 31 bit 0.

Table 64 - Framing Mode Select (R/W Address Y00) (T1)

Bit	Name	Functional Description
15-12	#	not used.
11-10	RZCS1-0 (00)	Receive Zero Code Suppression. 00: No Zero Code Suppression. 01: GTE Zero Code Suppression. 00000001 of an byte is detected and replaced by a 00000000 10: DDS Zero Code Suppression. 10011000 is detected as a zero byte and replaced by 00000000. 11: Bell Zero Code Suppression (Bit 7,00000010) is detected as a zero byte and replaced by a zero byte. These suppression detection codes only apply to the receiver. Note that the bit designations are with respect to the PCM24 side where bit 1 is sent and received first.
9-7	TZCS2-0 (000)	Transmit Zero Code Suppression. 000: No Zero Code Suppression. 001: GTE Zero Code Suppression. Bit 8 of an all zero channel byte is replaced by a one, except in signaling frames where bit 7 is forced to a one. 010: DDS Zero Code Suppression. An all zero byte is replaced by 10011000. 011: Bell Zero Code Suppression. Bit 7 of an all zero channel is replaced by a 00000010, 100: "Jammed bit 8". Bit 8 of all channels are replaced by a 1. These suppression codes only apply to the transmitter. Note that if a suppression code is enabled for a channel the B8ZS coding will not take place for the channel. Although 8 consecutive zeros in a non channel boundary will be subjected to B8ZS suppression. Note that the bit designations are with respect to the PCM24 side where bit 1 is sent and received first.
6	TPDV (0)	Transmit PDV. The output of the T1 data to be sent is monitored over a T1 frame and if the density is less than 12.5% a bit is added, in the non-framing bit.
5	TXB8ZS (0)	Transmit Bipolar Eight Zero Substitution. If set all zero octets in the transmit path are substituted with B8ZS codes.
4	RXB8ZS (0)	Receive Bipolar Eight Zero Substitution. If set B8ZS code words in the receive path are substituted with all zero octets. Bipolar violations associated with incoming B8ZS words will not be counted by the Bipolar Violation Error Counter.
3	ADSEQ (0)	Digital Milliwatt or Digital Test Sequence. If one, the Mulaw digital milliwatt analog test sequence will be selected for those channels with per timeslot control bits TTST, RRST set. If zero, a PRBS generator / detector will be connected to channels with TTST, RRST set.
2	RZNRZ (0)	Return to zero Non Return to zero. If one return to zero inputs and outputs are expected at the T1 interface. If zero, Non return to zero input and output are expected. RZ mode is only supported for bipolar input.
1	UNIBI (0)	Unipolar/Bipolar. If one the input and output at the T1 interface is assumed to be unipolar. The stream RPOS is the input and TPOS is the output. Setting this bit low causes the MT9072 to accept complementary bipolar inputs on RPOS/RNEG and to transmit complementary outputs on TPOS/TNEG.
0	CLKE (0)	Clock Edge. If one then the NRZ data(RPOS/RNEG) is sampled on the rising edge and transmitted on the falling edge of TXCL. If this bit is 0, then the opposite edges are used. This selection is only applicable in NRZ mode.

Table 65 - Line Interface and Coding Word(Y01) (T1)

Bit	Name	Functional Description
15-8	#	not used.
7	TESFYEL (0)	Transmit ESF Yellow Alarm. Setting this bit(while in ESF Mode) causes a repeating pattern of eight 1's followed by eight 0's to be sent on the transmit FDL bits. When JYEL is set, all ones signal is sent on the FDL.
6	TXSECY (0)	Transmit Secondary Yellow Alarm. When set to 1, the S-bit for transmit frame 12 will to be set to 1.
5	TD4YEL (0)	Transmit D4 Yellow Alarm. When set, bit 2 of all DS0 channels are forced low. The definition of Bit 2 is in accordance with Figure 41.
4	TAIS (1)	Transmit All Ones. When low, this control bit forces a framed or unframed (depending on the state of Transmit Alarm Control bit 0) all ones to be transmit at TTIP and TRING.
3	#	not used.
2	TT1DMY (1)	Transmit T1DM Yellow Alarm. If this bit is 0 a T1DM yellow alarm is sent on bit 2 of the 24th timeslot.
1	D4SECY (0)	D4 Secondary Alarm. Set this bit for trunks employing the secondary Yellow Alarm. The Fs bit in the 12th frame will not be used for counting errored framing bits. If a one is received in the Fs bit position of the 12th frame a Secondary Yellow Alarm Detect bit will be set.
0	SO (0)	S-bit Override. If set, this bit forces the S-bits to be inserted as an overlay on any of the following alarm conditions: i) transmit all ones, ii) loop up code insertion, iii) loop down code insertion.

Table 66 - Transmit Alarm Control Word(Y02) (T1)

Bit	Name	Functional Description
15-7	#	not used.
6	L32Z (0)	Digital Loss of Signal Selection. If one, the threshold for digital loss of signal is 32 successive zeros. If zero, the threshold is set to 192 successive zeros.
5	BPVE (0)	Bipolar Violation Error Insertion. A zero-to-one transition of this bit inserts a single bipolar violation error into the transmit DS1 data.
4	CRCE (0)	CRC-6 Error Insertion. A zero-to-one transition of this bit inserts a single CRC-6 error into the transmit ESF DS1 data.
3	FTE (0)	Terminal Framing Bit Error Insertion. A zero-to-one transition of this bit inserts a single error into the transmit D4 Ft pattern or the transmit ESF framing bit pattern (in ESF mode).
2	FSE (0)	Signal Framing Bit Error Insertion. A zero-to-one transition of this bit inserts a single error into the transmit Fs bits (in D4 mode only).
1	LOSE (0)	Loss of Signal Error Insertion. If one, the MT9072 transmits an all zeros signal (no pulses). Zero code suppression is overridden. If zero, data is transmitted normally.
0	PERR (0)	Payload Error Insertion. A zero - to - one transition of this bit inserts a single bit error in the transmit payload.

Table 67 - Transmit Error Control Word(Y03) (T1)

Bit	Name	Functional Description
15-10	#	not used.
9	CSIGEN (0)	Common Channel Signaling Enable. Setting this bit enables common channel signaling in conjunction with register Y0B. All other channels on the CSTo stream are tristate. Register Y0B defines the map between CST and PCM stream.
8	RBEN (0)	Robbed Bit Signaling Enable. Setting this bit multiplexes the AB or ABCD signaling bits into bit position 8 of all DS0 channels every 6th frame. Signaling is only sent in channels for which the CC bit in the per channel control word (Address Y90 - YA7) is set to 1.
7	not used	
6	RSDB (0)	Receive Signaling Debounce. Setting this bit causes incoming signaling bits to be debounced for a period of 6 to 9 milliseconds before reporting on CSTo streams or in the Receive signaling Bits Registers..
5	RFL (0)	Receive Signaling Freeze Due to Loss. If one, the receive signaling is frozen if a receive loss of signal is detected. The freeze is cleared upon clearance of Loss.
4	#	not used.
3-2	SM1-0 (00)	Signaling Message. These two bits are used to fill the vacant bit positions available on CSTo when the MT9072 is operating on a D4 trunk. The first two bits of each reporting nibble of CSTo contain the AB signaling bits. The last two will contain SM1 and SM0 (in that order). When the MT9072 is connected to ESF trunks four signaling bits (ABCD) are reported and the bits SM1-0 settings are ignored.
1-0	SIP1-0	Signaling Interrupt Period. These 2 bits determine the signaling Interrupt period due to the Receive signaling changes. This 2 bits determine the duration of the signaling interrupt bit CASRI(Y35). 00 2 Msec Period 01 8 Msec Period 10 16 Msec Period

Table 68 - Signaling Control Word (Y04) (T1)

Bit	Name	Functional Description
15-6	#	not used.
5	DLBK (0)	Digital Loopback. If one, then the digital streams (TPOS/TNEG) are looped to RPOS/RNEG. Data coming out of DSTo will be a delayed version of DSTi. Hence the data path is DSTi through the Transmitter to RPOS/RNEG and through the receiver to DSTo.
4	RLBK (0)	Remote Loopback. If one, then all timeslots received on RPOS/RNEG are connected to TPOS/TNEG on the DS1 side of the MT9072. If zero, then this feature is disabled.
3	STLBK (0)	ST-BUS Loopback. If one, then the last bit in the frame and the first 24 timeslots of DSTi are connected to the last bit in the frame and the first 24 timeslots of DSTo on the ST-BUS side of the MT9072. If zero, then this feature is disabled. See Loopbacks section.
2	PLBK (0)	Payload Loopback. If one, then all timeslots received on RPOS/RNEG are connected to TPOS/TNEG on the ST-BUS side of the MT9072. Hence DSTo is looped back to DSTi. If zero, then this feature is disabled. Set the bit RxDO (YF1 bit 9) for the payload loopback data to appear at the transmitter output.
1	TLU (0)	TxLoopUp Code. If this bit is set inband line loopup code is sent. The loopup code to be sent is determined by the Tx Loopup Code register. Note that the receiver will detect either framed or unframed inband loop codes.
0	TLD (0)	TxLoopDown Code. If this bit is set inband line loopdown code is sent. The loopdown code to be sent is determined by the Tx LoopDown Code register. If both TLU and TLD are set TLD takes precedence.

Table 69 - LoopBack Control Word (Y05) (T1)

Bit	Name	Functional Description
15-12	#	not used.
11-7	HCH4-0 (0)	HDLC Channel 4-0. This 5 bit number specifies the timeslot the HDLC will be attached to if enabled. Timeslot 0 is the first channel in the frame. Timeslot 23 is the last channel available in a T1 frame. If enabled in a channel, HDLC data will be substituted for data from DSTi on the transmit side. Receive data is extracted from the incoming line data before the elastic buffer.
6	HPAYSEL (0)	HDLC Payload Select. Set this bit to 1 to attach HDLC to a payload timeslot, if zero it is attached to the Facility Data Link when in the ESF mode.
5	E1.5CK (0)	Extracted 1.5 Data Link Clock. If one, the RxDLC pin outputs a 1.544 MHz clock signal derived from the 1.544MHz clock signal at the EXCLi pin. This clock is synchronous with the receive data before it passes through the elastic buffer at the RxDL pin. If zero, the RxDLC pin operates as a receive data link clock or enable signal as programmed by control bit DLCK (register address Y06).
4	DLCK (0)	Data Link Clock. If one, the TxDLC and RxDLC pins output a gapped clock. If zero, the TxDLC and RxDLC pins output an active low enable signal.
3	EDLEN (0)	Enable Data Link. Setting this bit multiplexes the serial stream clocked in on pin TxDL into the FDL bit position (ESF mode) or the Fs bit position (D4 mode).
2	BOMEN (0)	Bit Oriented Message Enable. Setting this bit enables transmission of bit - oriented messages on the ESF facility data link. The actual message transmitted at any one time is contained in the Tx BOM register (Y07).
1	HDLKEN (0)	HDLC Enable. If this bit is set and HPAYSEL is a zero than the internal HDLC is connected to the FDL bits in ESF Mode and TXDL/RXDL are not used for the dataLink. If 0 the datalink is sourced/sinked from TXDL/RXDL.
0	H1R64 (0)	HDLC Rate Select. Setting this bit high while the HDLC is activated on a timeslot enables 64 Kb/s operation. Setting this bit low while an HDLC is activated enables 56 Kb/s operation (this prevents data corruption due to forced bit stuffing).

Table 70 - HDLC & DataLink Control Word(Y06) (T1)

Bit	Name	Functional Description
15-8	#	not used.
7-0	TXBOM 7-0 (0)	Transmit Bit Oriented Message. The contents of this register are concatenated with a sequence of eight 1's and continuously transmit in the FDL bit position of ESF trunks. Normally the leading bit (bit 7) and last bit (bit 0) of this register are set to zero. Note that in accordance to T1.403 Table 11 the codeword 7E should not be used due to similarity of DataLink idle code.

Table 71 - Transmit Bit Oriented Message Register (Y07) (T1)

Bit	Name	Functional Description
15-8	#	not used.
7-0	RXBOM M7-0 (0)	Receive Bit Oriented Message Match. The contents of this register are compared to the received bit oriented message register(RXBOM) and an option maskable interrupt is generated if the contents match the received bit oriented message. Note that in accordance to T1.403 Table 11 the codeword 7E should not be used due to similarity of DataLink idle code. The code 7E will not be detected by the MT9072.

Table 72 - Receive Bit Oriented Message Match Register(Y08) (T1)

Bit	Name	Functional Description
15-8	#	not used.
7-0	RXIDC 7-0 (0)	Receive Idle Code. This is the idle code that is sent on the DSto channels if the per timeslot control bit MPDR is set(Y90-YA7).

Table 73 - Receive Idle Code Register(Y09) (T1)

Bit	Name	Functional Description
15-8	#	not used.
7-0	TXIDC 7-0 (0)	Transmit Idle Code. This is the idle code that is sent on the PCM24 channels if the per timeslot control bit MPDT is set(Y90-YA7).

Table 74 - Transmit Idle Code Register(Y0A) (T1)

Bit	Name	Functional Description
15-10	#	not used.
9-5	CST(4:0) (00000)	CST Map Channel. This is the CSTi/o channel which will be used as a source/destination to be mapped to the PCM24 channel. The possible values are 0 to 23 for channels 0 to 23 of the CSTi/o streams.
4-0	PCM(4:0) (00000)	PCM Map Channel. This is the PCM24 timeslot which will be used as a source/destination to be mapped to the CSTi/o channel. The possible values are 0 to 23 for timeslots 0 to 23 of the PCM24 stream.

Table 75 - Common Channel Signaling Map Register(Y0B) (T1)

Bit	Name	Functional Description
15-10	#	not used
9-8	TXLACL 1-0 (00)	Transmit Loop Activate Code Length. These 2 bits define the length of the transmit loop up code. 00-Code length is 5 bits 01-Code length is 6 or 3 bits 10-Code length is 7 bits 11-Code length is 8 or 4 bits Note: if 3 bit code or 4 bit code is required the bits have to be repeated in TXLDC7-0. For instance if the code 1011 is desired, the TXLAC has to be set to 10111011 and the length TXLACL to 11.
7-0	TXLAC7-0 (0000 0001)	Transmit Loop Activate Code. This byte specifies the inband loopup code to be transmitted. The default values are the T1.403 values for Loop Activate Code.

Table 76 - Transmit Loop Activate Code Register(Y0D) (T1)

Bit	Name	Functional Description
15-10	#	not used
9-8	TXLDCL 1-0 (01)	Transmit Loop Deactivate Code Length. These 2 bits define the length of the transmit loop down code. 00-Code length is 5 bits 01-Code length is 6 or 3 bits 10-Code length is 7 bits 11-Code length is 8 or 4 bits Note if 3 bit code or 4 bit code is required the bits have to be repeated in the TXLDC7-0. For instance if the code 1011 is desired, the TXLDC has to be set to 10111011 and TxDLCL to 11
7-0	TXLDC7-0 (0000 1001)	Transmit Loop Deactivate Code. This byte specifies the inband loopdown code to be transmitted. If 001 is to be transmitted as a loopdown code; the register has to programmed to a value of XX001001and the length (TXLDL has to be 01).The default values are the T1.403 values for Loop Deactivate Code.

Table 77 - Transmit Loop Deactivate Code Register(Y0E) (T1)

Bit	Name	Functional Description
15-10	#	not used
9-8	RXLACL 1-0 (00)	Receive Loop Activate Code Length. These 2 bits define the length of the receive loop up code. 00-Code length is 5 bits 01-Code length is 6 or 3 bits 10-Code length is 7 bits 11-Code length is 8 or 4 bits Note: if 3 bit code or 4 bit code is required the bits have to be repeated in RXLACM7-0. For instance if the code 1011 is desired the RXLACM has to be set to 10111011 and the RXLACL to 11. In case of the 3 bit code the 2 most significant bits of RXLACM are ignored.
7-0	RXLACM 7-0 (0000 0001)	Receive Loop Activate Code Match. This byte specifies the match code for the receive loopback activate code. A maskable interrupt can be generated if the loopback activate code message is received. This byte is compared to RXLAC. The default values are the T1.403 values for Loop Activate Code.

Table 78 - Receive Loop Activate Code Match Register(Y0F) (T1)

Bit	Name	Functional Description
15-10	#	not used
9-8	RXLDCL 1-0 (00)	Receive Loop Deactivate Code Length. These 2 bits define the length of the receive loop up code. 00-Code length is 5 bits 01-Code length is 6 or 3 bits 10-Code length is 7 bits 11-Code length is 8 or 4 bits Note: if 3 bit code or 4 bit code is required the bits have to be repeated in RXLACM7-0. For instance if the code 1011 is desired the RXLACM has to be set to 10111011 and the RXLACL to 11. In case of the 3 bit code the 2 most significant bits of RXLACM are ignored.
7-0	RXLDCM 7-0 (0000 0001)	Receive Loop Deactivate Code Match. This byte specifies the match code for the receive loopback activate code. A maskable interrupt can be generated if the loopback activate code message is received. This byte is compared to RXLAC. The default values are the T1.403 values for Loop Activate Code.

Table 79 - Receive Loop Deactivate code Match Register (R/W Address YF0)

16.1.3 Master Status Registers(Y10-Y18)Bit Functions

Tables 80 to 95 describe the bit functions of each of the Master Status Registers in the MT9072. Each register is repeated for each of the 8 framers. Framer 0 is addressed with Y=0, Framer 1 with Y=1, Framer 2 with Y=2... and Framer 7 with Y=7 (where Y represents the 4 most significant address bits (MSB) $A_{11}A_{10}A_9A_8$). All status bits will power up in the inactive state until the event happens.

Bit	Name	Functional Description
15-14	#	not used
13	TFSYNC	Terminal Frame Synchronization. Indicates the Terminal Frame Synchronization status (1 - loss; 0 - acquired). For ESF links terminal frame synchronization and multiframe synchronization are synonymous. This bit is also used for indicating T1DM sync gain or loss.
12	MFSYNC	Multiframe Synchronization. Indicates the Multiframe Synchronization status (1 - loss; 0 - acquired). For <u>ESF Mode</u> multiframe synchronization and terminal frame synchronization are synonymous. MFSYNC is relevant in all T1 Modes.
11	SE	Severely Errored Frame. This bit toggles when 2 of the last 6 received framing bits are in error. The framing bits monitored are the ESF framing bits for ESF links, a combination of Ft and Fs bits for D4 links (See Framing Mode Selection Word Y00) and T1DM Mode.
10	LOS	Digital Loss of Signal. This bit goes high after the detection of 192 or 32 consecutive zeros dependent on the setting of L32Z bit. It returns low when the incoming pulse density exceeds 12.5%.
9	D4YALM	D4 Yellow Alarm. This bit is set if bit position 2 of virtually every DS0 channel is a zero for a period of 600 milliseconds. The alarm is tolerant of errors by permitting up to 16 ones in a 48 millisecond integration period. The alarm clears in 200 milliseconds after being removed from the line. The alarm will also clear if four 48 msec intervals are detected with more than 16 ones in bit position 2.
8	D4Y48	D4 Yellow Alarm - 48 Millisecond Sample. This bit is set if bit position 2 of virtually every DS0 channel is a zero for a period of 48 milliseconds. The alarm is tolerant of errors by permitting up to 16 ones in the integration period. This bit is updated every 48 milliseconds.
7	SECYEL	Secondary D4 Yellow Alarm. This bit is set if 2 consecutive '1's are received in the S-bit position of the 12th frame of the D4 superframe.
6	ESFYEL	ESF Yellow Alarm. This bit is set if the ESF yellow alarm 0000000011111111 is received in eight or more codewords out of ten in the Bit oriented message location which are the FDL bits.
5	AIS	AIS Alarm. This bit is set if less than 5 zeros are received in a 3 millisecond window. The AIS bit is set to ahigh after power up.
4	PDV	Pulse Density Violation. This bit toggles if the receive data fails to meet ones density requirements. It will toggle upon detection of 16 consecutive zeros on the line data, or if there are fewer than N ones in a window of $8(N+1)$ bits - where $N = 1$ to 23.
3	LLED	Line Loopback Enable Detect. This bit will be set when a framed or unframed repeating pattern of 00001 has been detected during a 48 millisecond interval. Up to fifteen errors are permitted per integration period. Note that the code detected is dependent on Receive Loopback Activate Code Match(Y0F).

Table 80 - Synchronization and Alarm Status Word(Y10) (T1)

Bit	Name	Functional Description
2	LLDD (0)	Line Loopback Disable Detect. This bit will be set when a framed or unframed repeating pattern of 001 has been detected during a 48 millisecond interval. Up to fifteen errors are permitted per integration period. Note that the code detected is dependent on Receive Loopback Deactivate Code Match (YF0).
1	T1DRR (0)	T1DM Received R bit. This bit is used for AT&T 8 KB/s communications channel. This bit will be received in bit 1 of timeslot 24 of the receive PCM24 stream in T1DM mode.
0	T1DRY	T1DM Received Yellow Alarm. If this bit is 0 a T1DM yellow alarm has been detected in bit 2 of timeslot 24 of the receive PCM24 stream in T1DM mode.

Table 80 - Synchronization and Alarm Status Word(Y10) (T1)

Bit	Name	Functional Description
15-3	#	not used.
2	1SEC	One Second Timer Status. This bit changes state once every 1 second.
1	2SEC	Two Second Timer Status. This bit changes state once every 2 seconds and is synchronous with the 1 SEC timer.
0	#	not used.

Table 81 - Timer Status Word(Y11) (T1)

Bit	Name	Functional Description
15-10	#	not used.
9	RxBOM	Bit Oriented Message Received. This bit is set when a Received Bit Oriented Message is received.
8	RxBOMM	Receive Bit Oriented Match. This bit is set if there is a match between the Received Bit Oriented Message and Receive Bit oriented Match register.
7 - 0	RxBOM7 - 0	Receive Bit Oriented Message. This is the bit oriented message received. This register is updated after 8 out of 10 messages are received.

Table 82 - Receive Bit Oriented Message(Y12) (T1)

Bit	Name	Functional Description
15-14	#	not used.
13-11	PI2-0	Phase Indicator Bits (PI2 to PI0). These bits make up 3 least significant bits of a 12 bit word which indicate the delay through the receive slip buffer. The delay through the slip buffer in 2.048 Mhz bit cells is (512 - Phase Indicator bits). The delay to DSTo from the write into the slip buffer is (512 - Phase Indicator bits) + 16 bits. These bits are updated when the slip buffer write address is 0. These 3 bits will reflect the 1/2, 1/4 and 1/8 fractions of the Phase Indicator Bits.
10	RSLPD	Receive Slip Direction. If one, indicates that the last received frame slip resulted in a repeated frame, i.e., the system clock (C4b) is faster than network clock (EXCLi). If zero, indicates that the last received frame slip resulted in a lost frame, i.e., system clock slower than network clock. Updated on an RSLIP occurrence basis.
9	RxSLIP	Receive Slip. A change of state (i.e. 1-to-0 one 0-to-1) indicates that a receive controlled frame slip has occurred.
8	RxFRM	Receive Frame. The most significant bit of the phase status word. If one, the delay through the receive elastic buffer is greater than one frame in length; if zero, the delay through the receive elastic buffer is less than one frame in length.
7-3	RxTS4 - 0	Receive Timeslot. A five bit counter that indicates the number of timeslots between the receive elastic buffer internal write frame boundary and the ST-BUS read frame boundary. The count is updated every 250 uS.
2-0	RxBC2 - 0	Receive Bit Count. A three bit counter that indicates the number of ST-BUS bit times there are between the receive elastic buffer internal write frame boundary and the ST-BUS read frame boundary. The count is updated every 250 uS.

Table 83 - Receive Slip Buffer Status Word(Y13) (T1)

Bit	Name	Functional Description
15-11	#	not used.
10	TSLIP	Transmit Slip. A change of state (i.e., 1-to-0 or 0-to-1) indicates that a transmit controlled frame slip has occurred in the transmitter.
9	TSLPD	Transmit Slip Direction. If one, indicates that the last transmit frame slip resulted in a repeated frame, i.e., the internally generated 1.544 MHz. transmit clock is faster than the system clock (C4b). If zero, indicates that the last transmit frame slip resulted in a lost frame, i.e., the internally generated 1.544 MHz. transmit clock is slower than network clock. Updated on an TSLIP occurrence.
8	TxSBMSB	Transmit Slip Buffer MSB. The most significant bit of the Transmit Slip Buffer Delay Word. If one, the delay through the transmit elastic buffer is greater than one frame in length; if zero, the delay through the transmit elastic buffer is less than one frame in length. This bit is reset whenever Transmit Set Delay Bits (register address YF7) - are written to.
7-3	TxTS4 - 0	Transmit timeslot. A five bit counter that indicates the number of ST-BUS timeslots between the transmit elastic buffer ST-BUS write frame boundary and the internal transmit read frame boundary. The count is updated every 250 uS.
2-0	TxBC2 - 0	Transmit Bit Count. A three bit counter that indicates the number of ST-BUS bit times there are between the transmit elastic buffer ST-BUS write frame boundary and the internal read frame boundary. The count is updated every 250 uS.

Table 84 - Transmit Slip Buffer Status Word(Y14) (T1)

Bit	Name	Functional Description
15-8	PSM7-0	PRBS Multiframe Counter. This counter is incremented for each received CRC multiframe. It is cleared when the PRBS Error Counter is written to.
7-0	PS7-0	PRBS Error Counter. This counter is incremented for each PRBS error detected on any of the receive channels connected to the PRBS error detector.

Table 85 - PRBS Error Counter and CRC Multiframe Counter for PRBS(Y15) (T1)

Bit	Name	Functional Description
15-0	MFOOF15-0 (1)	Multiframes Out of Synchronization Counter. This 16 bit counter will be incremented once for every multiframe (1.5 milliseconds in D4 mode, 3 milliseconds in ESF mode) in which basic frame synchronization is lost. This counter presets to one upon reset. If terminal frame synchronization is never obtained, the MFOOF counter will keep incrementing every 1.5 or 3 msec (ESF Mode)

Table 86 - Multiframe Out of Frame Counter(Y16) (T1)

Bit	Name	Functional Description
15-0	FC15 - 0	Framing Bit Error Counter. This 16 bit counter will be incremented for each error in the received framing pattern. In ESF mode the ESF framing bits are monitored. In D4 mode the counter reflects the combination of Ft and Fs errors. The count is only active if the Framer is in synchronization.

Table 87 - Framing Bit Error Counter(Y17) (T1)

Bit	Name	Functional Description
15-0	BPV15-0	BPV Counter. 16 bit counter that is incremented for every bipolar violation error received.

Table 88 - Bipolar Violation Counter(Y18) (T1)

Bit	Name	Functional Description
15-0	CC15-0	CRC-6 Error Counter Bits 15 to Zero. These are the 16 bits of the CRC-6 error counter. This is only relevant in the ESF Mode. This counter increments for every CRC-6 error.

Table 89 - CRC-6 Error Counter(Y19) (T1)

Bit	Name	Functional Description
15-8	OOF7 - 0	Out Of Frame Counter. This eight bit counter is incremented with every loss of receive frame synchronization. Hence if you loss sync, gain sync and loss it again the counter will have a value of 2.
7-0	COFA7 - 0	Change of Frame Alignment Counter. This eight bit counter is incremented if a resynchronization is done which results in a shift in the frame alignment position.

Table 90 - Out of Frame and Change of Frame Counters(Y1A) (T1)

Bit	Name	Functional Description
15-8	#	not used.
7 - 0	EXZ7-0	Excessive Zero Counter. This counter is incremented once for detection of 8 or more zeros if B8ZS is turned on. This counter is incremented once if 16 or more zeros are detected if B8ZS is turned off. This counter counts groups of 8 or more or 16 or more zeros separated by ones.

Table 91 - Excessive Zero Counters(Y1B) (T1)

Bit	Name	Functional Description
15-12	#	not used.
11	RXclk	This bit represents the receiver clock generated after the RXEN control bit, but before zero deletion is considered.
10	TXclk	This bit represents the transmit clock generated after the TXEN control bit, but before zero insertion is considered.
9	Vcrc	This is the CRC recognition status bit for the receiver. Data is clocked into the register and then this bit is monitored to see if comparison was successful (bit will be high).
8	Vaddr	This is the address recognition status bit for the receiver. Data is clocked into the Address Recognition Register and then this bit is monitored to see if comparison was successful (bit will be high).
7-0	TBP7-0	Transmit Byte Counter Position. These 7 bits provide the position of the Transmit HDLC Byte Counter register (YF6). The counter is decremented as a byte of data is sent through the Transmit FIFO. When this register reaches the count of one, the next write to the Tx FIFO will be tagged as an end of packet byte. The counter decrements at the end of the write to the Tx FIFO. If the Cycle bit of YF2 is set high, the counter will cycle through the programmed value continuously.

Table 92 - Transmit Byte Counter Position and HDLC Test Status(Y1C) (T1)

Bit	Name	Functional Description
15-7	#	not used.
6	IDC	Idle Channel State. Is set to a 1 when an idle Channel state (15 or more ones) has been detected at the receiver. This is an asynchronous event. On power reset, this may be 1 if the clock (RXC) was not operating. Status becomes valid after the first 15 bits or the first zero is received.
5-4	RQ9-8	RQ9-8 Byte Status bits from RX FIFO. These bits determine the status of the byte to be read from RX FIFO as follows: 00 Packet Byte 01 First Byte 10 Last byte of good packet 11 Last byte of bad packet
3-2	TXSTAT1-0	Transmit FiFO Status: 00 Transmit FIFO is full. 01 The number of bytes in the transmit FIFO has reached or exceeded the 16 bytes threshold 10 Transmit FIFO is empty 11 The number of bytes in the TX FIFO is less than the 16 byte threshold.
1-0	RXSTAT1-0	Receive FiFO Status: 00 Receive FIFO is empty. 01 The number of bytes in the Receive FIFO are less than the 16 bytes 10 Receive FIFO is full 11 The number of bytes in the Receive FIFO is greater than or equal to the 16 byte threshold.

Table 93 - HDLC Status Word(Y1D) (T1)

Bit	Name	Functional Description
15-0	RCRC15-0	Received CRC. This register contains the CRC received from the transmitter. These bits are as the transmitter sent them, the LSB of the FCS sequence is MSB in this register. This register is updated at the end of each received packet and therefore should be read when end of packet is detected.

Table 94 - HDLC Receive CRC(Y1E) (T1)

Bit	Name	Functional Description
7-0	RXFIFO7-0	Receive FIFO. This is the received data byte read from the RX FIFO. The status bits of this byte can be read from the status register. The FIFO status is not changed immediately when a write or read occurs. It is updated after the data has settled and the transfer to the last available position has finished. Note that if the HDLC receiver is connected to an receive T1 channel, the bit that arrived first is stored in the least significant bit of the receive FIFO.

Table 95 - Receive FIFO(Y1F) (T1)

16.1.4 Latched Status Registers (Y20 - Y2F) Bit Functions

Tables 96 and 103 describe the bit functions of each of the Latched Status Registers in the MT9072 for T1. Each register is repeated for each of the 8 framers. Framer 0 is addressed with Y=0, Framer 1 with Y=1, Framer 2 with Y=2 ... and Framer 7 with Y=7 (where Y represents the 4 most significant address bits (MSB) A_{11}, A_{10}, A_9, A_8). All latched status registers will be reset in the inactive state upon reset.

Bit	Name	Functional Description
15-9	#	not used.
8	GAL	Go Ahead received Latch. Indicates a go-ahead pattern (01111111) was detected by the HDLC receiver. This bit is cleared after a read of Y23 or Y33.
7	EOPDL	End of Packet Data Latch. This bit is set when an end of packet (EOP) byte was written into the RX FIFO by the HDLC receiver. This can be in the form of a flag, an abort sequence or as an invalid packet. This bit is cleared after a read of Y23 or Y33.
6	TEOPL	Transmit End of Packet Latch. This bit is set when the transmitter has finished sending the closing flag of a packet or after a packet has been aborted. This bit is cleared after a read of Y23 or Y33.
5	EOPRL	End of Packet received latch. This bit is set when the byte about to be read from the RX FIFO is the last byte of the packet. It is also set if the Rx FIFO is read and there is no data in it. This bit is cleared after a read of Y23 or Y33.
4	TXFLL	Transmit Fifo Low Latch. This bit is set when the Tx FIFO is emptied below the 16 byte low threshold level. This bit is cleared after a read of Y23 or Y33.
3	FAL	Framer Abort Latch. This bit (FA) is set when a frame abort is received during packet reception. It must be received after a minimum number of bits have been received (26) otherwise it is ignored. This bit is cleared after a read of Y23 or Y33.
2	TxunderL	Txunder Latch. This bit is set for a TX FIFO underrun indication. If high it indicates that a read by the transmitter was attempted on an empty Tx FIFO. This bit is cleared after a read of Y23 or Y33.
1	RxffL	Receive Fifo Full Latch. This bit is set when the Rx FIFO is filled above the 16 byte full threshold level. This bit is reset after a read. This bit is cleared after a read of Y23 or Y33.
0	RXOvfl	Receive Overflow Latch. Indicates that the 32 byte RX FIFO overflowed (i.e. an attempt to write to a 32byte full RX FIFO). The HDLC will always disable the receiver once the receive overflow has been detected. The receiver will be re-enabled upon detection of the next flag, but will overflow again unless the RX FIFO is read. This bit is reset after a read. This bit is cleared after a read of Y23 or Y33.

Table 96 - HDLC Status Latch(Y23) (T1)

Bit	Name	Functional Description
15	FEOL	Framing Bit Error Counter Overflow Latch. This bit is set when the framing bit counter(Y17) overflows. This bit is cleared after a read of Y24 or Y34.
14	CRCOL	CRC-6 Error Counter Overflow Latch. This bit is set if the CRC6 error counter(Y19) overflows. This bit is cleared after a read of Y24 or Y34.
13	OOFOL	Out Of Frame Counter Overflow Latch. This bit is set when the OOF counter(Y1A) overflows. This bit is cleared after a read of Y24 or Y34.
12	COFAOL	Change of Frame Alignment Counter Overflow Latch. This bit is set when the change of frame alignment counter (Y1A) overflows. This bit is cleared after a read of Y24 or Y34.
11	BPVOL	Bipolar Violation Counter Overflow Latch. This bit is set when the bipolar violation counter(Y18) overflows.This bit is cleared after a read of Y24 or Y34.
10	PRBSOL	Pseudo Random Bit Sequence Error Counter Overflow Latch. This bit is set when the PRBS error counter(Y15) overflows. This bit is cleared after a read of Y24 or Y34.
9	PRBSMFOL	PRBS Multiframe Counter Overflow Latch. This bit is set when the PRBS multiframe counter(Y15) overflows. This bit is cleared after a read of Y24 or Y34.
8	MFOOFOL	Multiframe Out of Frame Counter Overflow Latch. This bit is set if the Multiframe Out of Frame Counter(Y16) overflows. This bit is cleared after a read of Y24 or Y34.
7	TFSYNL	Terminal Out Of Sync Latch. This bit is set when the terminal frame out of sync condition is acquired or lost. It is the latched version of the TFSYNC bit(Y10). This bit is cleared after a read of Y24 or Y34.
6	MFSYNL	Multiframes Out Of Sync Latch. This bit is set when the multiframes out of sync condition is acquired or lost. It is the latched version of the MFSYNC bit (Y10).This bit is cleared after a read of Y24 or Y34.
5	FBEL	Framing Bit Error Latch. This bit is set when a framing bit error is detected. It is cleared upon a read. It is the latched version of the Framing Bit Counter (Y17) event. This bit is cleared after a read of Y24 or Y34.
4	COFAL	Change of Frame Alignment Latch. This bit is set when the change of frame alignment occurs. This is the latched version of the count event to change of frame counter (Y1A). This bit is cleared after a read of Y24 or Y34.
3	SEFL	Severely Errored Frame Latch. This bit is set upon receipt of a line loopback disable code. This is a latched version of Y10. This bit is cleared after a read of Y24 or Y34.
2	AISL	AIS Latch. This bit is set upon receipt of an AIS. This is a latched version of AIS(Y10).This bit is cleared after a read of Y24 or Y34.
1	CRCL	CRC Error Latched. This bit is set when the receive CRC error occurs. This bit is cleared after a read of Y24 or Y34.
0	LOSL	Digital Loss of Signal. This bit goes high after the detection of 192 or 32 consecutive zeros. This is the latched version of LOS(Y10). This bit is cleared after a read of Y24 or Y34.

Table 97 - Receive Sync and Alarm Latch(Y24) (T1)

Bit	Name	Functional Description
15	D4YALML	D4 Yellow Alarm Latch. This bit is set if a D4 yellow alarm is detected within a 600 millisecond integration period. This bit is cleared after a read of Y25 or Y35.
14	D4Y48L	D4 Yellow Alarm (48 milliseconds) Latch. This bit is set if a D4 yellow alarm is detected within a 48 millisecond integration period. This bit is cleared after a read of Y25 or Y35.
13	SECYELL	Secondary D4 Yellow Alarm Latch. This bit is set if Secondary yellow alarm D4 (S bit in 12 th frame) is detected. It is cleared after a read. This bit is cleared after a read of Y25 or Y35.
12	ESFYELL	ESF Yellow Alarm Latch. This bit is set upon receipt of a ESF yellow alarm. This bit is cleared after a read of Y25 or Y35.
11	T1DMYL	T1DM Yellow Alarm Latched. If this bit is 1 a T1DM yellow alarm is received on bit 2 of 24th timeslot. This bit is cleared after a read of Y25 or Y35.
10	#	not used.
9	BPVL	Bipolar Violation Latch. This bit is set when a bipolar violation occurs. This bit is cleared after a read of Y25 or Y35.
8	PRBSL	PRBS Latch. This bit is set when a PRBS error has occurred. This bit is cleared after a read of Y25 or Y35.
7	PDVL	Pulse Density Violation Latch. This bit is set when the receive PDV is detected. This bit is cleared after a read of Y25 or Y35.
6	LLEDL	Line Loopback Enable Detect Latch. This bit is set upon receipt of a line loopback enable code. It is cleared after a read. This is a latched version of LLED(Y10). This bit is cleared after a read of Y25 or Y35.
5	LLDDL	Line Loopback Disable Detect Latch. This bit is set upon receipt of a line loopback disable code. It is cleared after a read. This is a latched version of LLDD(Y10). This bit is cleared after a read of Y25 or Y35.
4	BOML	Bit Oriented Message Latch. This bit is set if a bit oriented message has been received. It is cleared upon a read. This bit is cleared after a read of Y25 or Y35.
3	BOMML	Bit Oriented Message Match Latch. This bit is set if the bit oriented message received matches the value of the Bit Oriented Match register. This bit is cleared after a read of Y25 or Y35.
2	CASRL	Channel Associated signaling Received Latch. This bit is set if the received CAS has changed on any of the 24 channels. This bit is cleared after a read of Y25 or Y35.
1	1SECL	1 Second Latch. This bit is set if the one second timer expires. This bit is cleared after a read of Y25 or Y35.
0	2SECL	2 Second Latch. This bit is set if the two second timer expires. This bit is cleared after a read of Y25 or Y35.

Table 98 - Receive Line Status and Timer Latch(Y25) (T1)

Bit	Name	Functional Description
15-4	#	not used.
3	EXZOL	Excessive Zero Overflow Latch. This bit goes high whenever the excessive zero counter (Y1B) is overflows. This bit is cleared after a read of Y26 or Y36.
2	EXZL	Excessive Zero Latch. This bit goes high whenever the excessive zero counter (Y1B) is incremented by one. This bit is cleared after a read of Y26 or Y36.
1	TXSLIPL	Transmit SLIP Latch. This bit goes high whenever a transmit slip occurs. This bit is cleared after a read of Y26 or Y36.
0	RXSLIPL	Receive SLIP Latch. This bit goes high whenever a controlled frame slip occurs in the receive elastic buffer. This bit is cleared after a read of Y26 or Y36.

Table 99 - Elastic Store and Excessive Zero Status Latch(Y26) (T1)

Bit	Name	Functional Description
15-0	FCL<15:0>	Framing Bit Error Count Latch. These bits make up a latch which samples the current value of the Framing Bit Error Counter (address Y17) on the rising edge of the internal one second timer. This latch is cleared with a RESET ($\overline{\text{RESET}}$ pin or RST bit).

Table 100 - Framing Bit Error Count Latch(Y28) (T1)

Bit	Name	Functional Description
15-0	BPVL<15:0>	Bipolar Violation Count Latch. These bits make up a latch which samples the current value of the Bipolar Violation Error Counter (address Y18) on the rising edge of the internal one second timer. This latch is cleared with a RESET ($\overline{\text{RESET}}$ pin or RST bit).

Table 101 - Bipolar Violation Count Latch(Y29) (T1)

Bit	Name	Functional Description
15-0	CRCL<15:0>	CRC-6 Error Count Latch. These bits make up a latch which samples the current value of the CRC Error Counter (address Y19) on the rising edge of the internal one second timer. This latch is cleared with a RESET ($\overline{\text{RESET}}$ pin or RST bit).

Table 102 - CRC-6 Error Count Latch(Y2A) (T1)

Bit	Name	Functional Description
15-8	OOFL<7:0>	Out of Frame Alignment Count Latch. These bits make up a latch which samples the current value of the Change of Frame Alignment Counter (address Y1A) on the rising edge of the internal one second timer. This latch is cleared with a RESET ($\overline{\text{RESET}}$ pin or RST bit).
7-0	COFAL<7:0>	Change of Frame Alignment Count Latch. These bits make up a latch which samples the current value of the Change of Frame Alignment Counter (address Y1A) on the rising edge of the internal one second timer. This latch is cleared with a RESET ($\overline{\text{RESET}}$ pin or RST bit).

Table 103 - Out of Frame Count and Change of Frame Count Latch(Y2B) (T1)

Bit	Name	Functional Description
15-0	MFOOFL<15:0>	Multiframe OOF Count Latch. These bits make up a latch which samples the current value of the MFOOF Error Counter (address Y16) on the rising edge of the internal one second timer. This latch is cleared with a RESET ($\overline{\text{RESET}}$ pin or RST bit).

Table 104 - Multiframe Out of Frame Count Latch(Y2C) (T1)

16.1.5 Interrupt Status Registers (Y30 - Y3F) Bit Functions

Interrupt status register bit functions are shown in Tables 105 to 108.

Bit	Name	Functional Description
15-9	#	not used.
8	GAI	Go Ahead Interrupt. Indicates a go-ahead pattern (01111111) was detected by the HDLC receiver. This bit is reset after a read of Y33 or Y23.
7	EOPDI	End of Packet Data Interrupt. This bit is set when an end of packet (EOP) byte was written into the RX FIFO by the HDLC receiver. This can be in the form of a flag, an abort sequence or as an invalid packet. This bit is reset after a read of Y33 or Y23.
6	TEOPI	Transmit End of Packet Interrupt. This bit is set when the transmitter has finished sending the closing flag of a packet or after a packet has been aborted. This bit is reset after a read of Y33 or Y23.
5	EOPRI	End of Packet Receive Fifo Interrupt. This bit is set when the byte about to be read from the RX FIFO is the last byte of the packet. It is also set if the Rx FIFO is read and there is no data in it. This bit is reset after a read of Y33 or Y23.
4	TXFLI	Transmit FIFO Low Interrupt. This bit is set when the Tx FIFO is emptied below the 16 byte low threshold level. This bit is reset after a read of Y33 or Y23.
3	FAI	Frame Abort: Transmit Interrupt. This bit (FA) is set when a frame abort is received during packet reception. It must be received after a minimum number of bits have been received (26) otherwise it is ignored. This bit is reset after a read of Y33 or Y23.
2	TXUNDERI	Transmit Elastic Buffer Empty Interrupt. If high it Indicates that a read by the transmitter was attempted on an empty Tx FIFO. This bit is reset after a read of Y33 or Y23.
1	RXFFI	Receive FIFO is filled above Threshold Interrupt. This bit is set when the Rx FIFO is filled above the 16 byte full threshold level. This bit is reset after a read of Y33 or Y23.
0	RXOVFLI	Receive Fifo Overflow Interrupt This bit Indicates that the 32 byte RX FIFO overflowed (i/.e. an attempt to write to a 32 byte full RX FIFO). The HDLC will always disable the receiver once the receive overflow has been detected. The receiver will be re-enabled upon detection of the next flag, but will overflow again unless the RX FIFO is read. This bit is reset after a read of Y33 or Y23.

Table 105 - HDLC Interrupt Status Register(Y33) (T1)

Bit	Name	Functional Description
15	FEOI	Framing Bit Error Counter Overflow Interrupt. When unmasked this interrupt bit goes high whenever the framing bit error counter changes from FFH to 00H. This bit is reset after a read of Y34 or Y24.
14	CRCOI	CRC-6 Error Counter Overflow Interrupt. When unmasked this interrupt bit goes high whenever the CRC-6 error counter changes from FFH to 00H. This bit is reset after a read of Y34 or Y24.
13	OOFI	Out Of Frame Counter Overflow Interrupt. When unmasked this interrupt bit goes high whenever the out of frame counter changes state from changes from FFH to 00H. This bit is reset after a read of Y34 or Y24.
12	COFAOI	Change of Frame Alignment Counter Overflow Interrupt. When unmasked this interrupt bit goes high whenever the change of frame alignment counter changes from FFH to 00H. This bit is reset after a read of Y34 or Y24.
11	BPVOI	Bipolar Violation Counter Overflow Interrupt. When unmasked this interrupt bit goes high whenever the bipolar violation counter changes from FFH to 00H. This bit is reset after a read of Y34 or Y24.
10	PRBSOI	Pseudo Random Bit Sequence Error Counter Overflow Interrupt. When unmasked this interrupt bit goes high whenever the PRBS error counter changes from FFH to 00H. This bit is reset after a read of Y34 or Y24.
9	PRBSMFOI	Pseudo Random Bit Sequence MultiframeCounter Overflow Interrupt. When unmasked this interrupt bit goes high whenever the multiframe counter attached to the PRBS error counter change from. FFH to 00H. 1 - unmasked, 0 - masked. This bit is reset after a read of Y34 or Y24.
8	MFOFOI	Multiframes Out Of Sync Overflow Interrupt. When unmasked this interrupt bit goes high whenever the multiframes out of frame counter changes from FFH to 00H. This bit is reset after a read of Y34 or Y24.
7	TFSYNI	Terminal Frame Synchronization Interrupt. When unmasked this interrupt bit goes high whenever a change of state of terminal frame synchronization condition exists. This bit is reset after a read of Y34 or Y24.
6	MFSYNI	Multiframe Synchronization Interrupt. When unmasked this interrupt bit goes high whenever a change of state of multiframe synchronization condition exists. This bit is reset after a read of Y34 or Y24.
5	FBEI	Framing Bit Error Interrupt. When unmasked this interrupt bit goes high whenever an erroneous framing bit is detected (provided the circuit is in terminal frame sync). This bit is reset after a read of Y34 or Y24.
4	COFAI	Change of Frame Alignment Interrupt. When unmasked this interrupt bit goes high whenever a change of frame alignment occurs after a reframe. This bit is reset after a read of Y34 or Y24.
3	SEFI	Severely Errored Frame Interrupt. When unmasked this interrupt bit goes high whenever a sequence of 2 framing errors out of 6 occurs. This bit is reset after a read of Y34 or Y24.
2	AISI	Alarm Indication Signal Interrupt. When unmasked this interrupt bit goes high whenever a received all ones condition exists. This bit is reset after a read of Y34 or Y24.
1	CRCI	CRC-6 Error Interrupt. When unmasked this interrupt bit goes high whenever a local CRC-6 error occurs. This bit is reset after a read of Y34 or Y24.
0	LOSI	LOSS Interrupt. When unmasked this interrupt bit goes high upon loss of Signal. This bit is reset after a read of Y34 or Y24.

Table 106 - Receive Synchronization and Alarm Interrupt Status Register(Y34) (T1)

Bit	Name	Functional Description
15	D4YALMI	D4 Yellow Interrupt. When unmasked this interrupt bit goes high whenever the D4 Yellow alarm code has been received. This bit is reset after a read of Y35 or Y25.
14	D4Y48I	D4 Y48 Interrupt. When unmasked this interrupt bit goes high whenever the D4 Yellow alarm code has been received for 48 msec. This bit is reset after a read of Y35 or Y25.
13	SECYELI	Secondary Yellow Interrupt. When unmasked this interrupt bit goes high whenever a Secondary Yellow alarm is received. This bit is reset after a read of Y35 or Y25.
12	ESFYELI	ESF Yellow Interrupt. When unmasked this interrupt bit goes high whenever a ESF Yellow alarm is received. This bit is reset after a read of Y35 or Y25.
11	T1DMYI	T1DM Yellow Interrupt. When unmasked this interrupt bit goes high whenever a T1DM Yellow alarm is received. This bit is reset after a read of Y35 or Y25.
10	#	not used.
9	BPVI	Bipolar Violation Interrupt. When unmasked this interrupt bit goes high whenever a bipolar violation (excluding B8ZS encoding) is encountered. This bit is reset after a read of Y35 or Y25.
8	PRBSI	Pseudo Random Bit Sequence Error Interrupt. When unmasked this interrupt bit goes high upon detection of an error with a channel selected for PRBS testing. This bit is reset after a read of Y35 or Y25.
7	PDVI	Pulse Density Violation Interrupt. When unmasked this interrupt bit goes high whenever a sequence of 16 consecutive zeros is received on the line, or the incoming pulse density is less than N ones in a time frame of 8(N+1) where N = 1 to 23. This bit is reset after a read of Y35 or Y25.
6	LLEDI	Loop Code Enable Detected Interrupt. When unmasked this interrupt bit goes high whenever the loop up code has been detected on the line for a period of 48 milliseconds. This bit is reset after a read of Y35 or Y25.
5	LLDDI	Loop Code Disable Detected Interrupt. When unmasked this interrupt bit goes high whenever the loop down code has been detected on the line for a period of 48 milliseconds. This bit is reset after a read of Y35 or Y25.
4	BOMI	Bit Oriented Message Interrupt. When unmasked this interrupt bit goes high whenever a pattern 11111110xxxxx0 has been received on the FDL that is different from the last message. The new message must persist for 8 out the last 10 message positions to be accepted as a valid new message. Reading this register clears this bit. This bit is reset after a read of Y35 or Y25.
3	BOMMI	Bit Oriented Message Match Interrupt. When unmasked this interrupt bit goes high whenever a pattern 11111110xxxxx0 has been received on the FDL that is different from the last message and matches the contents of Bit Oriented Message Match Register. The new message must persist for 8 out the last 10 message positions to be accepted as a valid new message. This bit is reset after a read of Y35 or Y25.
2	CASRI	Receive Channel Associated signaling(CAS) Change Interrupt. When unmasked this interrupt bit goes high whenever a change of state (optionally debounced - see RSDB in signaling Control Word) is detected in the signaling bits (AB or ABCD) pattern. This bit is reset after a read of Y35 or Y25.
1	1SECI	One Second Interrupt Status. When unmasked this interrupt bit goes high whenever the 1SEC status bit goes from low to high. This bit is reset after a read of Y35 or Y25.
0	2SECI	Two Second Interrupt Status. When unmasked this interrupt bit goes high whenever the 2SEC status bit goes from low to high. This bit is reset after a read of Y35 or Y25.

Table 107 - Receive Line and Timer Interrupt Status (Y35) (T1)

Bit	Name	Functional Description
15-4	#	not used.
3	EXZOI	Excessive Zero Overflow Interrupt. This bit goes high whenever the excessive zero counter (Y1B) overflows. This bit is reset after a read of Y36 or Y26.
2	EXZI	EXcessive Zero Interrupt. This bit goes high whenever the excessive zero counter (Y1B) is incremented by one. This bit is reset after a read of Y36 or Y26.
1	TXSLIPI	Transmit SLIP Interrupt. When unmasked this interrupt bit goes high whenever a controlled frame slip occurs in the transmit elastic buffer. This bit is reset after a read of Y36 or Y26.
0	RXSLIPI	Receive SLIP Interrupt. When unmasked this interrupt bit goes high whenever a controlled frame slip occurs in the receive elastic buffer. This bit is reset after a read of Y36 or Y26.

Table 108 - Elastic Store and Excessive zero Interrupt Status Register(Y36) (T1)

16.1.6 Interrupt Mask Registers (Y40 - Y4F) Bit Functions

Tables 109 to 115 describe the bit functions of each of the Interrupt Mask Registers in the MT9072. Each register is repeated for each of the 4 framers (not the Interrupt Vector Mask). Framer 0 is addressed with Y=0, Framer 1 with Y=1, Framer 2 with Y=2, and Framer 7 with Y=7 (where Y represents the 4 most significant address bits (MSB) A11 A10 A9 A8). In addition, a simultaneous write to all 8 Framers is possible by setting the A11 address to Y=8 (1000). A (0) or (1) in the "Name" column of these tables indicates the state of the data bits after a hard reset (the RESET pin is toggled from zero to one), or a software reset (the RST bit in control register address YF1 is toggled from one to zero) or a T1E0 write to the Global Control Register bit 15.

Bit	Name	Functional Description
15-9	#	not used.
8	GAIM (0)	Go Ahead Interrupt Mask. When unmasked an interrupt is generated when go-ahead pattern (01111111) was detected by the HDLC receiver.
7	EOPDIM (0)	End of Packet Data Interrupt Mask. When unmasked an interrupt is initiated when an end of packet (EOP) byte was written into the RX FIFO by the HDLC receiver.
6	TEOPIM (0)	Transmit End of Packet Interrupt Mask. When unmasked an interrupt is initiated when the transmitter has finished sending the closing flag of a packet or after a packet has been aborted.
5	EOPRIM (0)	End of Packet Received Interrupt Mask. When unmasked an interrupt is initiated when the byte about to be read from the RX FIFO is the last byte of the packet. An interrupt is also initiated if the Rx FIFO is read and there is no data in it.
4	TXFLIM (0)	Transmit Fifo Low Interrupt Mask. When unmasked an interrupt is initiated when the Tx FIFO is emptied below the selected low threshold level.
3	FAIM (0)	Frame Abort: Transmit Interrupt Mask. When unmasked an interrupt is initiated this bit (FA) is set when a frame abort is received during packet reception. It must be received after a minimum number of bits have been received (26) otherwise it is ignored.
2	TXUNDERIM (0)	Transmit Fifo Underrun Interrupt Mask. When unmasked an interrupt is initiated for TX FIFO underrun indication.
1	RXFFIM (0)	Receive Fifo full Threshold interrupt Mask. When unmasked an interrupt is initiated whenever the Rx FIFO is filled above the 16 byte threshold level.
0	RXOVFLIM (0)	Receive Fifo Overflow Interrupt Mask. When unmasked an interrupt is initiated whenever the 32 byte RX FIFO overflowed (i.e. an attempt to write to a 32 byte full RX FIFO).

Table 109 - HDLC Interrupt Mask Register(Y43) (T1)

Bit	Name	Functional Description
15	FEOIM (0)	Framing Bit Error Counter Overflow Interrupt Mask. When unmasked an interrupt is initiated whenever the framing bit error counter changes from FFH to 00H. 1 - masked, 0 - unmasked.
14	CRCOIM (0)	CRC-6 Error Counter Overflow Interrupt Mask. When unmasked an interrupt is initiated whenever the CRC-6 error counter changes from FFH to 00H. 1 - masked, 0 - unmasked.
13	OFOIM (0)	Out Of Frame Counter Overflow Interrupt Mask. When unmasked an interrupt is initiated whenever the out of frame counter changes state from changes from FFH to 00H. 1 - masked, 0 - unmasked.

Table 110 - Receive and Sync Interrupt Mask Register(Y44) (T1)

Bit	Name	Functional Description
12	COFAOIM (0)	Change of Frame Alignment Counter Overflow Interrupt Mask. When unmasked an interrupt is initiated whenever the change of frame alignment counter changes from FFH to 00H. 1 - masked, 0 - unmasked.
11	BPVOIM (0)	Bipolar Violation Counter Overflow Interrupt Mask. When unmasked an interrupt is initiated whenever the bipolar violation counter changes from FFH to 00H. 1- masked, 0 - unmasked.
10	PRBSOIM (0)	Pseudo Random Bit Sequence Error Counter Overflow Interrupt Mask. When unmasked an interrupt will be generated whenever the PRBS error counter changes from FFH to 00H. 1 - masked, 0 -unmasked.
9	PRBSMFOIM (0)	Pseudo Random Bit Sequence Multiframe Counter Overflow Interrupt Mask. When unmasked an interrupt will be generated whenever the multiframe counter attached to the PRBS error counter overflows. FFH to 00H. 1 - masked, 0 - unmasked.
8	MFOOFOIM (0)	Multiframes Out Of Sync Overflow Interrupt Mask. When unmasked an interrupt will be generated when the multiframes out of frame counter changes from FFH to 00H. 1 - masked, 0 - unmasked.
7	TFSYNIM (0)	Terminal Frame Synchronization Interrupt Mask. When unmasked an interrupt is initiated when a loss of terminal frame synchronization condition exists. If 1 - masked, 0 - unmasked.
6	MFSYNIM (0)	Multiframe Synchronization Interrupt Mask. When unmasked an interrupt is initiated when a loss of multiframe synchronization condition exist. If 1 - masked, 0 - unmasked.
5	FBEIM (0)	Framing Bit Error Interrupt Mask. When unmasked an interrupt is initiated whenever an erroneous framing bit is detected (if circuit is in terminal frame sync). 1-masked, 0-unmasked.
4	BOMIM (0)	Bit Oriented Message Interrupt. When unmasked an interrupt is initiated whenever a pattern 11111110xxxxx0 has been received on the FDL that is different from the last message. The new message must persist for 8 out the last 10 message positions to be accepted as a valid new message. 1 -masked, 0 - unmasked.
3	BOMMI (0)	Bit Oriented Message Match Interrupt. When unmasked an interrupt is initiated whenever a pattern 11111110xxxxx0 has been received on the FDL that is different from the last message and matches the contents of Bit Oriented Message Match Register. The new message must persist for 8 out the last 10 message positions to be accepted as a valid new message. 1 -masked, 0 - unmasked.
2	CASRI (0)	Receive Channel Associated Signaling(CAS) Change Interrupt. When unmasked an interrupt is initiated whenever a change of state (optionally debounced - see RSDB in signaling Control Word) is detected in the signaling bits (AB or ABCD) pattern.
1	1SECI (0)	One Second Interrupt Status. When unmasked an interrupt is initiated whenever the 1 SEC status bit goes from low to high. This bit is reset after a read of Y35 or Y25.
0	2SECI (0)	Two Second Interrupt Status. When unmasked an interrupt is initiated whenever the 2SEC status bit goes from low to high. This bit is reset after a read of Y35 or Y25.

Table 110 - Receive and Sync Interrupt Mask Register(Y44) (T1)

Bit	Name	Functional Description
15	D4YALMIM (0)	D4 Yellow Interrupt Mask. When unmasked this interrupt bit goes high whenever the D4 Yellow alarm code has been received. If 1 - masked, 0 - unmasked.
14	D4Y48IM (0)	D4 Y48 Interrupt Mask. When unmasked this interrupt bit goes high whenever the D4 Yellow alarm code has been received for 48 msec. If 1 - masked, 0 - unmasked.
13	SECYELIM (0)	Secondary Yellow Interrupt Mask. When unmasked this interrupt bit goes high whenever a Secondary Yellow alarm is received. If 1 - masked, 0 - unmasked.
12	ESFYELIM (0)	ESF Yellow Interrupt Mask. When unmasked this interrupt bit goes high whenever a ESF Yellow alarm is received. If 1 - masked, 0 - unmasked.
11	T1DMYIM (0)	T1DM Yellow Interrupt Mask. When unmasked this interrupt bit goes high whenever a T1DM Yellow alarm is received. If 1 - masked, 0 - unmasked.
10	#	not used
9	BPVIM (0)	Bipolar Violation Interrupt Mask. When unmasked this interrupt bit goes high whenever a bipolar violation (excluding B8ZS encoding) is encountered. If 1 - masked, 0 - unmasked.
8	PRBSIM (0)	Pseudo Random Bit Sequence Error Interrupt Mask. When unmasked this interrupt bit goes high upon detection of an error with a channel selected for PRBS testing. If 1 - masked, 0 - unmasked.
7	PDVIM (0)	Pulse Density Violation Interrupt Mask. When unmasked this interrupt bit goes high whenever a sequence of 16 consecutive zeros is received on the line, or the incoming pulse density is less than N ones in a time frame of 8(N+1) where N = 1 to 23. If 1 - masked, 0 - unmasked.
6	LLEDIM (0)	Loop Code Enable Detected Interrupt Mask. When unmasked this interrupt bit goes high whenever the loop up code has been detected on the line for a period of 48 milliseconds. If 1 - masked, 0 - unmasked.
5	LLDDIM (0)	Loop Code Disable Detected Interrupt Mask. When unmasked this interrupt bit goes high whenever the loop down code has been detected on the line for a period of 48 milliseconds. If 1 - masked, 0 - unmasked.

Table 111 - Receive Line and Timer Interrupt Mask Register(Y45) (T1)

Bit	Name	Functional Description
15-4	#	not used.
3	EXZOI (0)	Excessive Zero Overflow Interrupt. This bit goes high whenever the excessive zero counter (Y1B) overflows. This bit is reset after a read of Y36 or Y26.
2	EXZI (0)	Excessive Zero Interrupt. This bit goes high whenever the excessive zero counter (Y1B) is incremented by one. This bit is reset after a read of Y36 or Y26.
1	TXSLIPIM (0)	Transmit SLIP Interrupt Mask. When unmasked an interrupt is initiated whenever a controlled frame slip occurs in the transmit elastic buffer. If 1 - masked, 0 - unmasked.
0	RXSLIPIM (0)	Receive SLIP Interrupt Mask. When unmasked an interrupt is initiated whenever a controlled frame slip occurs in the receive elastic buffer. If 1 - masked, 0 - unmasked.

Table 112 - Elastic Store and Excessive zero Interrupt Mask Register(Y46) (T1)

16.1.7 Per Channel Control and Data (Y50 - YAF) Bit Functions

Tables 112 to 114 provide the per timeslot control for signaling and Per Channel Control. The reset values of Per channel Transmit signaling and Receive signaling bits mcan be 1 or 0.

Bit	Name	Functional Description
15-4	#	not used.
3	TA(n)	Transmit Signaling Bits A for Channel n. Where signaling is enabled, these bits are transmitted in bit position 8 of the 6th DS1 frame (within the 12 frame superframe structure for D4 superframes and the 24 frame structure for ESF superframes). This data is obtained from the CSTi interface but can be overwritten via the Micro port for trunk conditioning applications. If the MPST bit in the corresponding per timeslot control is not set, this value will be constantly overwritten by the CSTi stream.
2	TB(n)	Transmit Signaling Bits B for Channel n. Where signaling is enabled, these bits are transmitted in bit position 8 of the 12th DS1 frame (within the 12 frame superframe structure for D4 superframes and the 24 frame structure for ESF superframes). This data is obtained from the CSTi interface but can be overwritten via the Micro port for trunk conditioning applications. If the MPST bit in the corresponding per timeslot control is not set, this value will be constantly overwritten by the CSTi stream.
1	TC(n)	Transmit Signaling Bits C for Channel n. Where signaling is enabled, these bits are transmitted in bit position 8 of the 18th DS1 frame within the 24 frame structure for ESF superframes. In D4 mode these bits are unused. This data is obtained from the CSTi interface but can be overwritten via the Micro port for trunk conditioning applications. If the MPST bit in the corresponding per timeslot control is not set, this value will be constantly overwritten by the CSTi stream.
0	TD(n)	Transmit Signaling Bits D for Channel n. Where signaling is enabled, these bits are transmitted in bit position 8 of the 24th DS1 frame within the 24 frame structure for ESF superframes. In D4 mode these bits are unused. This data is obtained from the CSTi interface but can be overwritten via the Micro port for trunk conditioning applications. If the MPST bit in the corresponding per timeslot control is not set, this value will be constantly overwritten by the CSTi stream.

Table 113 - Per Channel Transmit Signaling Y50-Y67 (T1)

Bit	Name	Functional Description
15 - 4	#	not used.
3	RA(n)	Receive Signaling Bits A for Channel n. Where signaling is enabled, these bits are received in bit position 8 of the 6th DS1 frame (within the 12 frame superframe structure for D4 superframes and the 24 frame structure for ESF superframes). This data can be overwritten by the microport for trunk conditioning applications.
2	RB(n)	Receive Signaling Bits B for Channel n. Where signaling is enabled, these bits are received in bit position 8 of the 12th DS1 frame (within the 12 frame superframe structure for D4 superframes and the 24 frame structure for ESF superframes). This data can be overwritten by the microport for trunk conditioning applications.
1	RC(n)	Receive Signaling Bits C for Channel n. Where signaling is enabled, these bits are transmitted in bit position 8 of the 18th DS1 frame within the 24 frame structure for ESF superframes. In D4 mode these bits are unused. This data can be overwritten by the microport for trunk conditioning applications.
0	RD(n)	Receive Signaling Bits D for Channel n. Where signaling is enabled, these bits are transmitted in bit position 8 of the 24th DS1 frame within the 24 frame structure for ESF superframes. In D4 mode these bits are unused. This data is obtained from the CSTi interface but can be overwritten via the Micro port for trunk conditioning applications. This data can be overwritten by the microport for trunk conditioning applications.

Table 114 - Per Channel Receive Signaling Y70-Y87 (T1)

Bit	Name	Functional Description
15-10	#	not used.
9	RPCI (0)	Receive Per Channel Inversion. The data received from the incoming DS1 channel is inverted before it emerges from DSTo if this bit is set for the channel.
8	MPDR (0)	Micro Port Data Receive. Setting this bit allows for the receive data for a given channel to be replaced by data in the idle code(Y09). The idle code can be written by the micro port for trunk conditioning applications.
7	MPST	Micro Port Signaling Transmit. Setting this bit allows for the transmit signaling for a given channel to be replaced by the bits in the Per Channel Transmit signaling Registration-TD of registers Y50-Y67. They can be written by the micro port for trunk conditioning applications.
6	TPCI (0)	Transmit Per Channel Inversion. When set high the data for this channel sourced from DSTi is inverted before being transmit onto the equivalent DS1 channel.
5	RTSL (0)	Remote Timeslot Loopback. If one, the corresponding DS1 receive timeslot is looped to the corresponding DS1 transmit timeslot. This received timeslot will also be present on DSTo. If zero, the receive loopback is disabled.
4	LTSL (0)	Local Timeslot Loopback. If one, the corresponding transmit timeslot is looped to the corresponding receive timeslot. This transmit timeslot will also be present on the transmit DS1 stream. If zero, this loopback is disabled.
3	TTST (0)	Transmit Test. If one the Mu-law digital milliwatt (where control bit ADSEQ is one) or a PRBS generator ($2^{15}-1$) (ADSEQ is zero) will be transmitted in the corresponding DS1 timeslot. More than one timeslot may be activated at once. If zero, the test signal will not be connected to the corresponding timeslot.
2	RRST (0)	Receive Test. If one, the Mu-law digital milliwatt (where control bit ADSEQ is one) will be sent to the DSTo or a PRBS data (215-1) (if ADSEQ is zero) will be expected in the corresponding PCM 24 timeslot. If zero, the PRBS detector will not be connected to the corresponding timeslot.
1	MPDT (0)	Micro Port Data Transmit. Setting this bit allows for the transmit data for a given channel to be replaced by the idle code(Y0A). The idle code can be written by the micro port for trunk conditioning applications. Ensure that TTST and RTSL are off.
0	CC (0)	Clear Channel. When set high no robbed bit signaling is inserted in the equivalent transmit DS1 channel. When set low robbed bit signaling is included in every 6th frame.

Table 115 - Per Channel Control Word(Y90-YA7) (T1)

16.1.8 Master Control Registers (YF1 to YF7) Bit Functions

Tables 116 to 122 describe the bit functions of each of the Master Control Registers in the MT9072 for T1 mode. Each register is repeated for each of the 8 framers. Framer 0 is addressed with Y=0, Framer 1 with Y=1, Framer 2 with Y=2,... Framer 7 with Y=7 (where Y represents the 4 most significant address bits (MSB) A₁₁ A₁₀ A₉ A₈). In addition, a simultaneous write to all 8 Framers is possible by setting the address A11 to 1 and A10 to A8 to 0. A (0), (1) or (#) in the "Name" column of these tables indicates the state of the data bits after a hard reset (the RESET pin is toggled from zero to one), or a software reset (the RST bit in control register address YF1 is toggled from one to zero or toggling of RSTC in Global Control Register). The (#) indicates that a (0) or (1) is possible.

Bit	Name	Functional Description
15-11	#	not used.
10	Tx8KEN (0)	Transmit 8 KHz Enable. If one, the pin $\overline{\text{RxMF}}$ transmits a positive 8 KHz frame pulse synchronous with the serial data stream TPOS/TNEG. If zero, the pin $\overline{\text{RxMF}}$ transmits a negative frame pulse synchronous with the multiframe boundary of data coming out of DSTo.
9	RxD0 (0)	Receive DSTo All Ones. If one, the DSTo pin operates normally. If zero, all timeslots (0-31) of DSTo are set to one.
8	TXMFSEL (0)	Transmit Multiframe Select. This bit is used to select if the framer is used for application of the TXMF pulse which sets the multiframe boundary for the T1 transmitters. A one will select the framer for application of TXMF.
7	SPND (0)	Suspend Interrupts. If zero, the IRQ output will be in a high-impedance state and all interrupts will be ignored. If one, the IRQ output will function normally.
6	INTA (0)	Interrupt Acknowledge. All interrupt and latched status registers for a particular framer may be cleared (without reading the interrupt status registers) by setting the INTA control bit to zero. Interrupt status registers for a particular framer will be cleared (and not updated) as long as INTA is low. The framers interrupt vector bits will remain at zero, therefore that framer cannot toggle the IRQ pin.
5	DSToEN (0)	DSTo Enable. If zero, pin DSTo is tristate. If set, pin DSTo is enabled.
4	CSToEN (0)	CSTo Enable. If zero, pin CSTo is tristate. If set, pin CSTo is enabled.
3	RxCO (0)	Receive CSTo All Ones. If one, the CSTo pin operates normally. If zero all timeslots of CSTo are set to one
2	CNTCLR (0)	Counter Clear. When this bit is changed from zero to one, all non-latched status counters (address Y15 to Y1A) are cleared. If zero, all non-latched status counters operate normally.
1	SAMPLE (0)	One Second Sample. Setting this bit causes the latched error counters(Y28 to Y2C) (change of frame alignment, loss of frame alignment, bpv errors, crc errors, severely errored frame events and multiframes out of sync) to be updated on one second intervals coincident with the one second timer (Y11).
0	RST (0)	Reset. When this bit is changed from zero to one, the selected framer (Y) will reset to its default mode. The default mode will depend on the T1E0 bit(Global control0 bit 15). Any write to his bit should be followed by 125 usec before initialization of per timeslot control etc. See the Reset Operation section for the default settings.

Table 116 - Interrupt and I/O Control(YF1) (T1)

Bit	Name	Functional Description
15-11	#	not used.
10	ADREC (0)	Address Recognition. When high, this bit will enable address recognition. This forces the receiver to recognize only those packets having the unique address as programmed in the Receive Address Recognition Registers or if the address is an All Call Address.
9	RXEN (0)	Receive Enable. When low this bit will disable the HDLC receiver. The receiver will disable after the rest of the packet presently being received is finished. The receiver's internal clock is disabled. When high the receiver will be immediately enabled (depending on the state of RXCEN input) and will begin searching for flags, Go-aheads etc.
8	TXEN (0)	Transmit Enable. When low this bit will disable the HDLC transmitter. The transmitter will disable after the completion of the packet presently being transmitted. The transmitter's internal clock is disabled. When high the transmitter will be immediately enabled (depending on the state of the TXCEN input) and will begin transmitting data, or go to a mark idle or interframe time fill state.
7	EOP (0)	End of Packet When set this bit will indicate an end of packet byte to the transmitter, which will transmit an FCS following this byte. This facilitates loading of multiple packets into TX FIFO. Reset automatically after a write to the TX FIFO occurs.
6	FA (0)	Framer Abort. Forms a tag on the next byte written to the TX FIFO, and when set will indicate to the transmitter that it should abort the packet in which that byte is being transmitted. Reset automatically after a write to the TX FIFO.
5	MI (0)	Mark-Idle. When low, the transmitter will be in an idle state. When high it is in an interframe time fill state. These two states will only occur when the TX FIFO is empty.
4	CYCLE (0)	Cycle. When high, this bit will cause the transmit byte count to cycle through the value loaded into the Transmit Byte Count Register.
3	TCRCI (0)	Transmit CRC Inhibit. When high, this bit will inhibit transmission of the CRC. That is, the transmitter will not insert the computed CRC onto the bit stream after seeing the EOP tag byte. This is used in V.120 terminal adaptation for synchronous protocol sensitive UI frames.
2	SEVEN (0)	Seven. When high, this bit will enable seven bits of address recognition in the first address byte. The received address byte must have bit 0 equal to 1 which indicates a single address byte is being received.
1	RXFRST (0)	Rx Fifo Reset. When high, the RX FIFO will be reset. This causes the receiver to be disabled until the next reception of a flag. The status register will identify the FIFO as being empty. However, the actual bit values in the RX FIFO will not be reset.
0	TXFRST (0)	Transmit FIFO Reset When high, the TX FIFO will be reset. The Status Register will identify the FIFO as being empty. This bit will be reset when data is written to the TX FIFO. However, the actual bit values of data in the TX FIFO will not be reset.

Table 117 - HDLC Control 1(YF2) (T1)

Bit	Name	Functional Description
15-6	#	not used.
5	HRST (0)	HDLC Reset. When this bit is high, the HDLC and HDLC registers will be reset (HDLC Control, HDLC Test Control, Address Recognition Byte). This is similar to RESET being applied, the only difference being that this bit will not be reset. This bit can only be reset by writing a zero to this location or applying RESET.
4	RTLOOP (0)	Receive Transmit Loopback. When this bit is high, receive to transmit HDLC loopback will be activated. Receive data, including end of packet indication, but not including flags or CRC, will be written to the TX FIFO as well as the RX FIFO. When the transmitter is enabled, this data will be transmitted as though written by the microprocessor. Both good and bad packets will be looped back. Receive to transmit loopback may also be accomplished by reading the RX FIFO using the microprocessor and writing these bytes, with appropriate tags, into the TX FIFO.
3	CRCTST (0)	CRC Test. This bit allows direct access to the CRC Comparison Register in the receiver through the serial interface. After testing is enabled, serial data is clocked in until the data aligns with the internal comparison (16 RXC clock cycles) and then the clock is stopped. The expected pattern is F0B8 hex. Each bit of the CRC can be corrupted to allow more efficient testing.
2	FTST (0)	Fifo Test. This bit allows the writing to the RX FIFO and reading of the TX FIFO through the microprocessor to allow more efficient testing of the FIFO status/interrupt functionality. This is done by making a TX FIFO write become a RX FIFO write and a RX FIFO read become a TX FIFO read. In addition, EOP/FA and RQ8/RQ9 are re-defined to be accessible (i.e. RX write causes EOP/FA to go to RX fifo input; TX read looks at output of TX fifo through RQ8/RQ9 bits).
1	ADTST (0)	Address Recognition Test. This bit allows direct access to the Address Recognition Registers in the receiver through the serial interface to allow more efficient testing. After address testing is enabled, serial data is clocked in until the data aligns with the internal address comparison (16 RXc clock cycles) and then clock is stopped. Then the VADDR bit in Y1C can be checked.
0	HLOOP (0)	HDLC Loopback. When high, transmit to receive HDLC loopback will be activated. The packetized transmit data will be looped back to the receive input. RXEN and TXEN bits must also be enabled.

Table 118 - HDLC Test Control(YF3) (T1)

Bit	Name	Functional Description
15-9	ADM26 - ADM20 (0000000)	Address Mask 26 to Address Mask 20. A seven bit mask used to interrogate the second byte of the received address. Adr26 is the MSB. This mask is ignored (as well as first byte mask) if all call address (1111111) is received.
8	A2EN (0)	Address 2 Enable. When this bit is high, this seven bit mask is used in address comparison of the second address byte. If address recognition is enabled, any packet failing the address comparison will not be stored in the RX FIFO. A2en must be high for All-call address recognition. When this bit is low, this bit mask is ignored in address comparison
7 - 2	ADRM16 - ADRM11 (000000)	Address Mask 16 to Address Mask 11. A six bit mask used to interrogate the first byte of the received address. AdrM16 is MSB.
1	ADRM10 (0)	Address 10 Mask. This bit is used in address comparison if a seven bit address is being checked for (YF2 bit 'Seven' is set).
0	A1EN (0)	Address 1 Enable. When this bit is high, this six (or seven) bit mask is used in address comparison of the first address byte. If address recognition is enabled, any packet failing the address comparison will not be stored in the RX FIFO. A1en must be high for All-call (1111111) address recognition for single byte address. When this bit is low, this bit mask is ignored in address comparison.

Table 119 - Address Recognition Register(YF4) (T1)

Bit	Name	Functional Description
15-8	#	not used.
7 - 0	BIT7-0 (00000000)	This eight bit word is tagged with the two status bits from control register 1 (EOP and FA), and the resulting 10 bit word is written to the TX FIFO. The FIFO status is not changed immediately after a write or read occurs. It is updated after the data has settled and the transfer to the last available position has finished. Note that when the HDLC is connected to a T1 channel, the least significant bit in the FIFO is sent first.

Table 120 - TX Fifo Write Register(YF5) (T1)

Bit	Name	Functional Description
15-8	#	not used.
7-0	CNT7-0 (00000000)	The Transmit Byte Count Register indicating the length of the data portion of the packet about to be transmitted. This is the size of the data and not the address, flags or FCS. The Transmit Byte Counter position Y1C determines the number of bytes that have been sent from the Transmit FIFO.

Table 121 - TX Byte Count Register(YF6) (T1)

Bit	Name	Functional Description
15-8	#	not used.
7-0	TxSD7-0 (00000000)	<p>Transmit Set Delay Bits 7 - 0. Writing to this register forces a one time setting of the delay through the transmit slip buffer. The binary value written to the Transmit Set Delay Bits defines the delay between the write of the Transmit ST-BUS Channel containing DS1 timeslot 1 (first timeslot) and its read from the slip buffer.</p> <p>If the value written to the Transmit Set Delay Bits is 00H to BFH then the delay can be calculated as: $(\text{Value}) / (1.544 \times 10^6)$ seconds.</p> <p>If the value written to the Transmit Set Delay Bits is C0H to FFH then the delay can be calculated as: $(255 - \text{value}) / (2.048 \times 10^6)$ seconds.</p> <p>After a reset there will be an immediate transmit slip and the subsequent delay through the transmit slip buffer will be one frame.</p>

Table 122 - TX Set Delay Bits (YF7) (T1)

16.1.9 Global Control and Status Registers (900 - 91F) Bit Functions

The Global Control and Status Registers are common to the T1 and E1 operation. The global registers are accessed by address hex 9xx (A₁₁ and A₈ being high and A₁₀ and A₉ being low)

Bit	Name	Functional Description												
15	T1E0 (1)	T1E0. This bit determines if the chip will operate in T1 or E1 mode for all 8 framers. If the value of this bit is changed the chip is reset in E1 or T1 default register mode. If the bit is set to 1, all the framer register values are set to T1 defaults. For a setting of 0 the register values are set to E1 defaults. This action takes approximately 34 1.5444 clock cycles. Hence any writes to registers should be done on the next 125 usec frame after setting or clearing this bit.												
14	STBUS (0)	ST-BUS Enable. If zero, ST-BUS timing is enabled. If one, GCI timing is enabled (only available for 2.048Mb/s mode). See Figures 24-31.												
13-5	#	not used.												
4	CK1 (0)	Clock Rate. This clock select bit determines the system clock at the CKi pin and the receive frame pulse at the FPi pin as follows (See Figures 24 to 31): <table border="1" style="margin-left: 20px;"> <thead> <tr> <th>CK1</th> <th>Clock</th> <th>Frame Pulse</th> <th>System Bus</th> </tr> </thead> <tbody> <tr> <td>0</td> <td>4.096MHz</td> <td>2.048Mb/s</td> <td>2.048Mb/s</td> </tr> <tr> <td>1</td> <td>16.384MHz</td> <td>8.192Mb/s</td> <td>8.192Mb/s</td> </tr> </tbody> </table>	CK1	Clock	Frame Pulse	System Bus	0	4.096MHz	2.048Mb/s	2.048Mb/s	1	16.384MHz	8.192Mb/s	8.192Mb/s
CK1	Clock	Frame Pulse	System Bus											
0	4.096MHz	2.048Mb/s	2.048Mb/s											
1	16.384MHz	8.192Mb/s	8.192Mb/s											
3-1	#	not used.												
0	RSTC (0)	Common Reset. When this bit is changed from zero to one, all <u>eight framers</u> will reset to their default T1 mode. This software reset has the same effect as the RESET pin. See the Reset Operation section for the default settings.												

Table 123 - Global Control0 Register (R/W Address 900) (T1)

Bit	Name	Functional Description
15-11	CHANNUM (00000)	Channel Number. These 5 bits determine the channel that is used for updating of the ST-Bus Analyzer buffer.
10-8	#	not used.
7-6	STRNUM (00000)	Stream Number. These 5 bits determine the streams that will be used as the source data for the ST-Bus Analyzer buffer. 00: DSTi 01: DSTo 10: CSTi 11: CSTo
5	STBUFEN (0)	ST-BUS Analyser Buffer Enable. Setting this bit enables the ST-BUS Analyser Buffer update. When the user reads the buffer (920-93F), this bit must be 0. Any reads of the buffer while this bit is set does not ensure correct data being read.
4-2	FNUM (2:0) (000)	Framer Number 0 to 7
1	CHUP (0)	Channel Update. If 0 the update of the memory is at frame rate for a given channel. The channel selected for update is provided by the ChanNum bits of this register. If set the complete frame (channels 0 to 32) are updated to the buffer.
0	CONTSIN (0)	Continuous Single. If set to 1 the ST-BUS Analyzer buffer is updated continuously. If set to zero the buffer is updated once and stopped. An optional interrupt can be generated once the buffer is full.

Table 124 - Global Control1 Register (R/W Address 901) (T1)

Bit	Name	Functional Description
15	F3HM (0)	Framer 3 HDLC Mask. This is the mask bit for the F3HVS status bit in the Interrupt Vector Register(address 910). If this mask bit is one, the corresponding Interrupt Vector status bit will remain inactive (zero). If this mask bit is zero, the corresponding Interrupt Vector status bit will function normally.
14	F3EM (0)	Framer 3 Elastic Mask. This is the mask bit for the F3EVS status bit in the Interrupt Vector Register (address 910). If this mask bit is one, the corresponding Interrupt Vector status bit will remain inactive (zero). If this mask bit is zero, the corresponding Interrupt Vector status bit will function normally.
13	F3RM (0)	Framer 3 Rx Line Mask. This is the mask bit for the F3RVS status bit in the Interrupt Vector Register (address 910). If this mask bit is one, the corresponding Interrupt Vector status bit will remain inactive (zero). If this mask bit is zero, the corresponding Interrupt Vector status bit will function normally.
12	F3SM (0)	Framer 3 Sync and Overflow Mask. This is the mask bit for the F3SVS status bit in the Interrupt Vector Register (address 910). If this mask bit is one, the corresponding Interrupt Vector status bit will remain inactive (zero). If this mask bit is zero, the corresponding Interrupt Vector status bit will function normally.
11	F2HM (0)	Framer 2 HDLC Mask. This is the mask bit for the F2HVS status bit in the Interrupt Vector Register (address 910). If this mask bit is one, the corresponding Interrupt Vector status bit will remain inactive (zero). If this mask bit is zero, the corresponding Interrupt Vector status bit will function normally.
10	F2EM (0)	Framer 2 Elastic Mask. This is the mask bit for the F2EVS status bit in the Interrupt Vector Register (address 910). If this mask bit is one, the corresponding Interrupt Vector status bit will remain inactive (zero). If this mask bit is zero, the corresponding Interrupt Vector status bit will function normally.
9	F2RM (0)	Framer 2 Rx Line Mask. This is the mask bit for the F2RVS status bit in the Interrupt Vector Register(address 910). If this mask bit is one, the corresponding Interrupt Vector status bit will remain inactive (zero). If this mask bit is zero, the corresponding Interrupt Vector status bit will function normally.
8	F2SM (0)	Framer 2 Sync and Overflow Mask. This is the mask bit for the F2SVS status bit in the Interrupt Vector Register (address 910). If this mask bit is one, the corresponding Interrupt Vector status bit will remain inactive (zero). If this mask bit is zero, the corresponding Interrupt Vector status bit will function normally.
7	F1HM (0)	Framer 1 HDLC Mask. This is the mask bit for the F1HVS status bit in the Interrupt Vector Register(address 910). If this mask bit is one, the corresponding Interrupt Vector status bit will remain inactive (zero). If this mask bit is zero, the corresponding Interrupt Vector status bit will function normally.
6	F1EM (0)	Framer 1 Elastic Mask. This is the mask bit for the F1EVS status bit in the Interrupt Vector Register(address 910). If this mask bit is one, the corresponding Interrupt Vector status bit will remain inactive (zero). If this mask bit is zero, the corresponding Interrupt Vector status bit will function normally.
5	F1RM (0)	Framer 1 Rx Line Mask. This is the mask bit for the F1RVS status bit in the Interrupt Vector Register(address 910). If this mask bit is one, the corresponding Interrupt Vector status bit will remain inactive (zero). If this mask bit is zero, the corresponding Interrupt Vector status bit will function normally.

Table 125 - Interrupt Vector 1 Mask Register (Address 902) (T1)

Bit	Name	Functional Description
4	F1SM (0)	Framer 1 Sync and Overflow Mask. This is the mask bit for the F1SVS status bit in the Interrupt Vector Register (address 910). If this mask bit is one, the corresponding Interrupt Vector status bit will remain inactive (zero). If this mask bit is zero, the corresponding Interrupt Vector status bit will function normally.
3	F0HM (0)	Framer 0 HDLC Mask. This is the mask bit for the F0HVS status bit in the Interrupt Vector Register (address 910). If this mask bit is one, the corresponding Interrupt Vector status bit will remain inactive (zero). If this mask bit is zero, the corresponding Interrupt Vector status bit will function normally.
2	F0EM (0)	Framer 0 Elastic Mask. This is the mask bit for the F0EVS status bit in the Interrupt Vector Register (address 910). If this mask bit is one, the corresponding Interrupt Vector status bit will remain inactive (zero). If this mask bit is zero, the corresponding Interrupt Vector status bit will function normally.
1	F0RM (0)	Framer 0 Rx Line Mask. This is the mask bit for the F0RVS status bit in the Interrupt Vector Register (address 910). If this mask bit is one, the corresponding Interrupt Vector status bit will remain inactive (zero). If this mask bit is zero, the corresponding Interrupt Vector status bit will function normally.
0	F0SM (0)	Framer 0 Sync and Overflow Mask. This is the mask bit for the F0SVS status bit in the Interrupt Vector Register (address 910). If this mask bit is one, the corresponding Interrupt Vector status bit will remain inactive (zero). If this mask bit is zero, the corresponding Interrupt Vector status bit will function normally.

Table 125 - Interrupt Vector 1 Mask Register (Address 902) (T1)

Bit	Name	Functional Description
15	F7HM (0)	Framer 7 HDLC Mask. This is the mask bit for the F7HVS status bit in the Interrupt Vector Register (address 910). If this mask bit is one, the corresponding Interrupt Vector status bit will remain inactive (zero). If this mask bit is zero, the corresponding Interrupt Vector status bit will function normally.
14	F7EM (0)	Framer 7 Elastic Mask. This is the mask bit for the F7EVS status bit in the Interrupt Vector Register (address 911). If this mask bit is one, the corresponding Interrupt Vector status bit will remain inactive (zero). If this mask bit is zero, the corresponding Interrupt Vector status bit will function normally.
13	F7RM (0)	Framer 7 Rx Line Mask. This is the mask bit for the F7RVS status bit in the Interrupt Vector Register (address 911). If this mask bit is one, the corresponding Interrupt Vector status bit will remain inactive (zero). If this mask bit is zero, the corresponding Interrupt Vector status bit will function normally.
12	F7SM (0)	Framer 7 Sync and Overflow Mask. This is the mask bit for the F7SVS status bit in the Interrupt Vector Register (address 911). If this mask bit is one, the corresponding Interrupt Vector status bit will remain inactive (zero). If this mask bit is zero, the corresponding Interrupt Vector status bit will function normally.
11	F6HM (0)	Framer 6 HDLC Mask. This is the mask bit for the F6HVS status bit in the Interrupt Vector Register (address 910). If this mask bit is one, the corresponding Interrupt Vector status bit will remain inactive (zero). If this mask bit is zero, the corresponding Interrupt Vector status bit will function normally.
10	F6EM (0)	Framer 6 Elastic Mask. This is the mask bit for the F6EVS status bit in the Interrupt Vector Register (address 911). If this mask bit is one, the corresponding Interrupt Vector status bit will remain inactive (zero). If this mask bit is zero, the corresponding Interrupt Vector status bit will function normally.

Table 126 - Interrupt Vector 2 Mask Register (Address 903) (T1)

Bit	Name	Functional Description
9	F6RM (0)	Framer 6 Rx LineMask. This is the mask bit for the F6RVS status bit in the Interrupt Vector Register (address 911). If this mask bit is one, the corresponding Interrupt Vector status bit will remain inactive (zero). If this mask bit is zero, the corresponding Interrupt Vector status bit will function normally.
8	F6SM (0)	Framer 6 Sync and Overflow Mask. This is the mask bit for the F6SVS status bit in the Interrupt Vector Register (address 911). If this mask bit is one, the corresponding Interrupt Vector status bit will remain inactive (zero). If this mask bit is zero, the corresponding Interrupt Vector status bit will function normally.
7	F5HM (0)	Framer 5 HDLC Mask. This is the mask bit for the F5HVS status bit in the Interrupt Vector Register (address 910). If this mask bit is one, the corresponding Interrupt Vector status bit will remain inactive (zero). If this mask bit is zero, the corresponding Interrupt Vector status bit will function normally.
6	F5EM (0)	Framer 5 Elastic Mask. This is the mask bit for the F5EVS status bit in the Interrupt Vector Register (address 911). If this mask bit is one, the corresponding Interrupt Vector status bit will remain inactive (zero). If this mask bit is zero, the corresponding Interrupt Vector status bit will function normally.
5	F5RM (0)	Framer 5 Rx Line Mask. This is the mask bit for the F5RVS status bit in the Interrupt Vector Register (address 911). If this mask bit is one, the corresponding Interrupt Vector status bit will remain inactive (zero). If this mask bit is zero, the corresponding Interrupt Vector status bit will function normally.
4	F5SM (0)	Framer 5 Sync and Overflow Mask. This is the mask bit for the F5SVS status bit in the Interrupt Vector Register (address 911). If this mask bit is one, the corresponding Interrupt Vector status bit will remain inactive (zero). If this mask bit is zero, the corresponding Interrupt Vector status bit will function normally.
3	F4HM (0)	Framer 4 HDLC Mask. This is the mask bit for the F4HVS status bit in the Interrupt Vector Register (address 910). If this mask bit is one, the corresponding Interrupt Vector status bit will remain inactive (zero). If this mask bit is zero, the corresponding Interrupt Vector status bit will function normally.
2	F4EM (0)	Framer 4 Elastic Mask. This is the mask bit for the F4EVS status bit in the Interrupt Vector Register (address 911). If this mask bit is one, the corresponding Interrupt Vector status bit will remain inactive (zero). If this mask bit is zero, the corresponding Interrupt Vector status bit will function normally.
1	F4RM (0)	Framer 4 Rx Line Mask. This is the mask bit for the F4RVS status bit in the Interrupt Vector register(address 911). If this mask bit is one, the corresponding Interrupt Vector status bit will remain inactive (zero). If this mask bit is zero, the corresponding Interrupt Vector status bit will function normally.
0	F4SM (0)	Framer 4 Sync and Overflow Mask. This is the mask bit for the F4SVS status bit in the Interrupt Vector Register (address 911). If this mask bit is one, the corresponding Interrupt Vector status bit will remain inactive (zero). If this mask bit is zero, the corresponding Interrupt Vector status bit will function normally.

Table 126 - Interrupt Vector 2 Mask Register (Address 903) (T1)

Bit	Name	Functional Description
15	SLBK8 (0)	ST-BUS Loopback 8M All. If one, DSTo[0] is connected to DSTi[4], and DSTo[4] is connected to DSTi[0]. This can be used in 8.192 Mbit/s or 2.048 Mbit/s mode. See Loopbacks section.
14	SLBK67 (0)	ST-BUS Loopback Framer 6 & 7. If one, DSTo[6] is connected to DSTi[7], and DSTo[7] is connected to DSTi[6]. Used only in 2.048Mb/s mode. See Loopback section for details.
13	SLBK45 (0)	ST-BUS Loopback Framer 4 & 5. If one, DSTo[4] is connected to DSTi[5], and DSTo[5] is connected to DSTi[4]. Used only in 2.048Mb/s mode. See Loopbacks section.
12	SLBK23 (0)	ST-BUS Loopback Framer 2 & 3. If one, DSTo[2] is connected to DSTi[3], and DSTo[3] is connected to DSTi[2]. Used only in 2.048Mb/s mode. See Loopbacks section.
11	SLBK01 (0)	ST-BUS Loopback Framer 0 & 1. If one, DSTo[0] is connected to DSTi[1], and DSTo[1] is connected to DSTi[0]. Used only in 2.048Mb/s mode. See Loopbacks section.
10	RLBK8 (0)	Remote Loopback 8 Framers. If one, TPOS[0]/TNEG[0] are connected to RPOS[4]/RNEG[4], and TPOS[4]/TNEG[4] are connected to RPOS[0]/RNEG[0]. This is used especially for 8.192 Mbit/s mode but may also be used in 2.048 Mbit/s mode. See Loopbacks section.
9	RLBK67 (0)	Remote Loopback Framer 6 & 7. If one, TPOS[6]/TNEG[6] are connected to RPOS[7]/RNEG[7], and TPOS[7]/TNEG[7] are connected to RPOS[6]/RNEG[6]. Used only in 2.048Mb/s mode. See Loopbacks section.
8	RLBK45 (0)	Remote Loopback Framer 4 & 5. If one, TPOS[4]/TNEG[4] are connected to RPOS[5]/RNEG[5], and TPOS[5]/TNEG[5] are connected to RPOS[4]/RNEG[4]. Used only in 2.048Mb/s mode. See Loopbacks section.
7	RLBK23 (0)	Remote Loopback Framer 2 & 3. If one, TPOS[2]/TNEG[2] are connected to RPOS[3]/RNEG[3], and TPOS[3]/TNEG[3] are connected to RPOS[2]/RNEG[2]. Used only in 2.048Mb/s mode. See Loopbacks section.
6	RLBK01 (0)	Remote Loopback Framer 0 & 1. If one, TPOS[0]/TNEG[0] are connected to RPOS[1]/RNEG[1], and TPOS[1]/TNEG[1] are connected to RPOS[0]/RNEG[0]. Used only in 2.048Mb/s mode. See Loopbacks section.
5-0	#	not used

Table 127 - Framer Loopback Global Register(904) (T1)

Bit	Name	Functional Description
15-1	#	not used.
0	STM (0)	ST-BUS Analyser Mask. This is the mask bit for the F0STVS status bit in the ST-BUS Interrupt Vector Register (address 913). If this mask bit is one, the corresponding Interrupt Vector status bit will remain inactive (zero). If this mask bit is zero, the corresponding Interrupt Vector status bit will function normally.

Table 128 - ST-Bus Interrupt Vector Mask(905) (T1)

Bit	Name	Functional Description
15	F3HVS (0)	Framer 3 HDLC Vector Status. This bit if unmasked is set if any of the bits in the Interrupt HDLC register(333) for framer are set. This bit can be masked and will remain low by the F3HM bit in address 902.
14	F3EVS (0)	Framer 3 Elastic Vector Status. This bit if unmasked is set if any of the bits in the Interrupt Receive Elastic store register(336) or Elastic store status for Framer 3 are set. This bit can be masked and will remain low by the F3EM bit in address 902.
13	F3RVS (0)	Framer 3 Rx Line Vector Status. This bit if unmasked is set if any of the bits in the Interrupt Receive Line status register(335) for Framer 0 are set. This bit can be masked and will remain low by the F3RM bit in address 902.
12	F3SVS (0)	Framer 3 Sync Vector Status. This bit if unmasked is set if any of the bits in the Interrupt Sync status register(334) for Framer 3 are set. This bit can be masked and will remain low by the F3SM bit in address 902.
11	F2HVS (0)	Framer 2 HDLC Vector Status. This bit if unmasked is set if any of the bits in the Interrupt HDLC register(233) or Elastic store status far Framer 2 are set. This bit can be masked and will remain low by the F2HM bit in address 902.
10	F2EVS (0)	Framer 2 Elastic Vector Status. This bit if unmasked is set if any of the bits in the Interrupt Receive Elastic status register(236) or Elastic store status for Framer 2 are set. This bit can be masked and will remain low by the F2EM bit in address 902.
9	F2RVS (0)	Framer 2 Rx Line Vector Status. This bit if unmasked is set if any of the bits in the Interrupt Receive Line status register(235) for Framer 2 are set. This bit can be masked and will remain low by the F2RM bit in address 902.
8	F2SVS (0)	Framer 2 Sync Vector Status. This bit if unmasked is set if any of the bits in the Interrupt Counter status register(234) for Framer 2 are set. This bit can be masked and will remain low by the F2SM bit in address 902.
7	F1HVS (0)	Framer 1 HDLC Vector Status. This bit if unmasked is set if any of the bits in the Interrupt HDLC register(133) or Elastic store status for Framer 1 are set. This bit can be masked and will remain low by the F2HM bit in address 902.
6	F1EVS (0)	Framer 1 Elastic Vector Status. This bit if unmasked is set if any of the bits in the Interrupt Receive Elastic store register(136) or Elastic store status for Framer 1 are set. This bit can be masked and will remain low by the F1EM bit in address 902.
5	F1RVS (0)	Framer 1 Rx Line Vector Status. This bit if unmasked is set if any of the bits in the Interrupt Receive Line status register(135) for Framer 1 are set. This bit can be masked and will remain low by the F1RM bit in address 902.
4	F1SVS (0)	Framer 1 Sync Vector Status. This bit if unmasked is set if any of the bits in the Interrupt Sync status register(134) for Framer 3 are set. This bit can be masked and will remain low by the F1SM bit in address 902.
3	F0HVS (0)	Framer 0 HDLC Vector Status. This bit if unmasked is set if any of the bits in the Interrupt HDLC register(033) or Elastic store status for Framer 0 are set. This bit can be masked and will remain low by the F0HM bit in address 902.

Table 129 - Interrupt Vector 1 Status Register (Address 910) (T1)

Bit	Name	Functional Description
2	F0EVS (0)	Framer 0 Elastic Vector Status. This bit if unmasked is set if any of the bits in the Interrupt Receive Elastic store register(036) or Elastic store status for Framer 0 are set. This bit can be masked and will remain low by the F0EM bit in address 902.
1	F0RVS (0)	Framer 0 Rx Line Vector Status. This bit if unmasked is set if any of the bits in the Interrupt Receive Line status register(035) for Framer 0 are set. This bit can be masked and will remain low by the F0RM bit in address 902.
0	F0SVS (0)	Framer 0 Sync Vector Status. This bit if unmasked is set if any of the bits in the Interrupt Sync status register(034) for Framer 0 are set. This bit can be masked and will remain low by the F0SM bit in address 902.

Table 129 - Interrupt Vector 1 Status Register (Address 910) (T1)

Bit	Name	Functional Description
15	F7HVS (0)	Framer 3 HDLC Vector Status. This bit if unmasked is set if any of the bits in the Interrupt HDLC register(733) for Framer 7 are set. This bit can be masked and will remain low by the F7HM bit in address 903.
14	F7EVS (0)	Framer 7 Elastic Vector Status. This bit if unmasked is set if any of the bits in the Interrupt HDLC register(736) or Elastic store status for Framer 7 are set. This bit can be masked and will remain low by the F7EM bit in address 903.
13	F7RVS (0)	Framer 7 Rx Line Vector Status. This bit if unmasked is set if any of the bits in the Interrupt HDLC register(735) for Framer 7 are set. This bit can be masked and will remain low by the F7RM bit in address 903 .
12	F7SVS (0)	Framer 7 Sync Vector Status. This bit if unmasked is set if any of the bits in the Interrupt HDLC register(734) for Framer 3 are set. This bit can be masked and will remain low by the F7SM bit in address 903.
11	F6HVS (0)	Framer 6 HDLC Vector Status. This bit if unmasked is set if any of the bits in the Interrupt HDLC register(663) or Elastic store status for Framer 6 are set. This bit can be masked and will remain low by the F7HM bit in address 903.
10	F6EVS (0)	Framer 6 Elastic Vector Status. This bit if unmasked is set if any of the bits in the Interrupt Receive Elastic store register(636) or Elastic store status for Framer 5 are set. This bit can be masked and will remain low by the F5EM bit in address 903.
9	F6RVS (0)	Framer 6 Rx Line Vector Status. This bit if unmasked is set if any of the bits in the Interrupt Receive Line status register(635) for Framer 6 are set. This bit can be masked and will remain low by the F6RM bit in address 903.
8	F6SVS (0)	Framer 6 Sync Vector Status. This bit if unmasked is set if any of the bits in the Interrupt Counter status register(634) for Framer 6 are set. This bit can be masked and will remain low by the F6SM bit in address 903.
7	F5HVS (0)	Framer 3 HDLC Vector Status. This bit if unmasked is set if any of the bits in the Interrupt HDLC register(533) or Elastic store status for Framer 5 are set. This bit can be masked and will remain low by the F7HM bit in address 903.
6	F5EVS (0)	Framer 5 Elastic Vector Status. This bit if unmasked is set if any of the bits in the Interrupt Receive Elastic store register(536) or Elastic store status for Framer 5 are set. This bit can be masked and will remain low by the F5EM bit in address 903.

Table 130 - Interrupt Vector 2 Status Register (Address 911) (T1)

Bit	Name	Functional Description
5	F5RVS (0)	Framer 5 Rx Line Vector Status. This bit if unmasked is set if any of the bits in the Interrupt Receive Line status register(535) are Framer 5 are set. This bit can be masked and will remain low by the F1RM bit in address 903.
4	F5SVS (0)	Framer 5 Sync Vector Status. This bit if unmasked is set if any of the bits in the Interrupt Sync status register(534) for Framer 5 are set. This bit can be masked and will remain low by the F1SM bit in address 903.
3	F4HVS (0)	Framer 4 HDLC Vector Status. This bit if unmasked is set if any of the bits in the HDLC status register(433)status for Framer 4 are set. This bit can be masked and will remain low by the F7HM bit in address 903.
2	F4EVS (0)	Framer 4 Elastic Vector Status. This bit if unmasked is set if any of the bits in the Interrupt Receive Elastic store register(436) or Elastic store status for Framer 4 are set. This bit can be masked and will remain low by the F4EM bit in address 903.
1	F4RVS (0)	Framer 4 Rx Line Vector Status. This bit if unmasked is set if any of the bits in the Interrupt Receive Line status register(435) for Framer 4 are set. This bit can be masked and will remain low by the F4RM bit in address 903.
0	F4SVS (0)	Framer 4 Sync Vector Status. This bit if unmasked is set if any of the bits in the Interrupt Sync status register(434) Framer 4 are set. This bit can be masked and will remain low by the F4SM bit in address 903.

Table 130 - Interrupt Vector 2 Status Register (Address 911) (T1)

Bit	Name	Functional Description
15-3	ID15-3	ID Number. Contains 0100000001011.
2-0	ID2-0 (000)	These 3 bits make up a binary code which identify the revision of this device.

Table 131 - Identification Revision Code Data Register (Address 912) (T1)

Bit	Name	Functional Description
15-1	#	not used.
0	STIS (0)	ST-BUS Analyser Interrupt Status. This bit (if unmasked) is set if the ST-BUS Analyser is filled up. This bit can be masked and by the FSTM bit in address 905.

Table 132 - ST-BUS Analyzer Vector Status Register (Address 913) (T1)

Bit	Name	Functional Description
15-8	#	not used.
7-0	STAD (7-0) (0)	ST-BUS Analyser Data. This is the data for the ST-BUS analyser buffer. 920 is the first byte of the data that is being "analyzed". The source of the data can be any ST-Bus stream from any Framer.

Table 133 - ST-BUS Analyser Data(Address 920-93F) (T1)

16.2 E1 Register Set

16.2.1 Register Address (000 - FFF) Summaries

16.2.1.1 Framer Address (000-FFF) Summary

Binary Address (A ₁₁ -A ₀)	Hex Address	Framer Accessed
0000 xxxx xxxx	0XX	0
0001 xxxx xxxx	1XX	1
0010 xxxx xxxx	2XX	2
0011 xxxx xxxx	3XX	3
0100 xxxx xxxx	4XX	4
0101 xxxx xxxx	5XX	5
0110 xxxx xxxx	6XX	6
0111 xxxx xxxx	7XX	7
1000 xxxx xxxx	8XX	0 - 7, this performs an all framer write to register XX, except for the following addresses which are common to all 8 framers:
1001 xxxx xxxx	900	Global Control 0(R/W)
	901	Global Control 1(R/W)
	902	Interrupt Vector 1 Mask Register (R/W)
	903	Interrupt Vector 2 Mask Register (R/W)
	904	Framer Loopback Register (R/W)
	905	ST-BUS Analyser Interrupt Mask Register
	910	Interrupt Vector1 Status Register(R)
	911	Interrupt Vector2 Status Register(R)
	912	ID Register (R)
	913	ST-BUS Analyser Interrupt Status Register
	920-93F	ST-BUS Analyser Data
1010 0100 0000 - 1111 1111 1111	940 - FFF	not used
xxxx indicates all (0000 to 1111) binary possibilities	X indicates all (0 to F) hex possibilities	

Table 134 - Framer Addressing (000 - FFF) (E1)

16.2.1.2 Register Group Address (Y00 - YFF) Summary

Binary Address (A ₁₀ -A ₀)	Hex Address	Register Group Accessed	Processor Access	ST-BUS Access
yyyy 0000 xxxx	Y0X,YFX	Master Control	R/W	---
yyyy 0001 xxxx	Y1X	Master Status	R	---
yyyy 0010 xxxx	Y2X	Latched Status	R	---
yyyy 0011 xxxx	Y3X	Interrupt Status	R	---
yyyy 0100 xxxx	Y4X	Interrupt Mask Control	R/W	---
yyyy 0101 xxxx	Y5X-Y6X	Transmit CAS Data	R/W	CSTi
yyyy 0110 xxxx	Y7X-Y8X	Receive CAS Data	R	CSTo
yyyy 0111 xxxx- yyyy 1000 xxxx	Y9X-YAX	Timeslot 0-31 Control	R/W	---
yyyy 1001xxxx	YB0-YBF	Transmit National Bit Buffers	R/W	
yyyy 1010 xxxx	YC0-YCF	Receive National Bit Buffers	R	

yyyy indicates 9 binary (0000 to 1000) possibilities, 0000 to 0111 representing a read or write to 1 of 8 framers, 1000 representing a write only to all framers, or a read/write to one of the common registers (904,912,910, 911,902,903)
 Y is the hex equivalent of yyyy
 xxxx indicates all (0000 to 1111) binary possibilities
 X is the hex equivalent of xxxx

Table 135 - Register Group Address (Y00 - YFF) Summary (E1)

16.2.1.3 Global Control and Status Register (900-91F) Summary

Binary Address (A ₁₁ -A ₀)	Hex Address	R/W	Register	Control Bits (B15 - B8 / B7 - B0)
1001 0000 0000	900	R/W	Global Control0	T1Eo, $\overline{\text{STBUS}}$,###,###,###,###,CK1,###,RSTC
1001 0000 0001	901	R/W	Global Control1	CHANNUM(4:0),STBUFEN,FRNUM(2:0),CHUP,CONTSI N
1001 0000 0000	902	R/W	Interrupt Vector Mask Register	F3HM, F3NM, F3CM, F3SM, F2HM, F2NM, F2CM, F2SM, F1HM, F1NM, F1CM, F1SM, F0HM, F0NM, F0CM, F0SM
1001 0000 0011	903	R/W	Interrupt Vector Mask Register	F7HM,F7NM,F7CM,F7SM,F6HM,F6NM,F6CM,F6SM, F5HM,F5NM,F5CM,F5SM,F4HM,F4NM,F4CM,F4SM
1001 0000 1000	904	R/W	Framer Loopback Global Register	SLBK8, SLBK67, SLBK45, SLBK23, SLBK01, RLBK8, RLBK67, RLBK45, RLBK23, RLBK01, #, #, #, #, #
1001 0000 0101	905	R/W	Framer 0 ST-Bus Analyser Interrupt Mask Register	F0STM
1001 0000 0101- 1001 0000 1111	906-90F	R/W	not used	not used
1001 0001 0000	910	R	Interrupt Vector Status 0	F3HS,F3EVS, F3RVS, F3SVS,F2HS, F2EVS, F2RVS, F2SVS, F1HS,F1EVS, F1RVS, F1SVS,F0HS, F0EVS, F0RVS F0SVS
1001 0001 0001	911	R	Interrupt Vector Status1	F7HS,F7EVS, F7RVS, F7SVS,F6HS, F6EVS, F6RVS, F6SVS, F5HS,F5EVS, F5RVS, F5SVS,F4HS, F4EVS, F4RVS F4SVS
1001 0001 0010	912	R	Identification Code Status	###,###, #, #, #, ID7-0
	913	R	ST-Bus Analyser Interrupt Status Register	F0STS
1001 0001 0011- 1001 0001 1111	914-91F		not used	not used
	920-93F	R	ST-Bus Analyser Data	STAD(7:0)
# indicates unused bits in register that may be any value if read				

Table 136 - Register Group Address (Y00 - YFF) Summary (E1)

16.2.2.2 Master Status Registers Address (Y10-Y1F) Summary

Binary Address (A ₁₀ -A ₀)	Hex Address	R/W	Register	Status Bits (B15 - B8 / B7 - B0)
yyyy 0001 0000	Y10	R	Synchronization & CRC-4 Remote Status	#, RSLP, RSLPD, BSYNC, MSYNC, CSYNC, RED, CEFS, #, RCRC0, RCRC1, RFAIL, REB1-2, RCRCR, CRCIW
yyyy 0001 0001	Y11	R	CRC-4 Timers & CRC-4 Local Status	#, #, #, TWOSEC, T1, T2, T400, T8, #, #, #, CALN, CRCRF, CRCS1, CRCS2, #
yyyy 0001 0010	Y12	R	Alarms & MAS Status	#, AISP, KLVE, LOSS, AIS16, AIS, RAI, AUXP, RMA1-4, X1, Y, X2, X3
yyyy 0001 0011	Y13	R	NFAS & FAS Status	RIU1, RNFA, RAI, RNU4-8, RIU0, RFA2-8
yyyy 0001 0100	Y14	R	Phase Indicator Status	#, #, #, #, PI11-8, PI7-0
yyyy 0001 0101	Y15	R/W	PRBS Error Counter & PRBS CRC-4 MF Counter	PEC7-0, PCC7-0
yyyy 0001 0110	Y16	R/W	Loss of Sync Counter with Auto Clear	SLC15-8, SLC7-0
yyyy 0001 0111	Y17	R/W	E-bit Error Counter	EEC15-8, EEC7-0
yyyy 0001 1000	Y18	R/W	BPV Error Counter	VEC15-8, VEC7-0
yyyy 0001 1001	Y19	R/W	CRC-4 Error Counter	CEC15-8, CEC7-0
yyyy 0001 1010	Y1A	R/W	FAS Bit Error Counter FAS Error Counter	BEC7-0 FEC7-0
yyyy 0001 1011	Y1B	R/W	not used	
yyyy 0001 1100	Y1C	R/W	TX Byte Counter Position and HDLC Test Status	#, #, #, #, RXclk, TXclk, Vcrc, Vaddr, TBP7:0
yyyy 0001 1101	Y1D	R/W	HDLC Status	IDC, RQ9-8, TXSTAT1-0, RXSTA1-0
yyyy 0001 1110	Y1E	R/W	RX CRC	CRC15-0
yyyy 0001 1111	Y1F	R/W	RX FIFO	#, #, #, #, #, #, #, #, RXFIFO7-0
# indicates the unused bits in the register that may be any value if read see the Register Group Address Summary for an explanation of yyyy and Y				

Table 138 - Master Status Register (R) Address (Y1X) Summary (E1)

16.2.2.3 Latched Status Registers Address (Y20-Y2F) Summary

Binary Address (A ₁₀ -A ₀)	Hex Address	R/W	Latched Status Register	Status Bits (B15 - B8 / B7 - B0)
yyyy 0010 0000- yyyy 0010 0011	Y20-Y23	-	not used	not used
yyyy 0010 0100	Y24	R	Sync (Sync, CRC-4 Remote, Alarms, MAS and Phase)	CASRL, RCRCRL, RSLPL, YL, AUXPL, RAIL, AISL, AIS16L, LOSSL, RCRC0L, RCRC1L, CEFSL, RFAILL, CSYNCL, MSYNCL, BSYNCL
yyyy 0001 0101	Y25	R	Counter (Counter Indication and Counter Overflow)	SLOL, 0, FEOL, FEIL, BEOL, BEIL, CEOL, CEIL, VEOL, VEIL, EEOL, EEIL, PCO, 0, PEOL, PEIL
yyyy 0001 0110	Y26	R	National (CAS, National, CRC-4 Local and Timers)	0, Sa5VL, Sa6V3L, Sa6V2L, Sa6V1L, Sa6V0L, Sa6N8L, Sa6NL, SaNL, Sa5TL, SaTL, CASRL, CALNL, T2L, T1L, ONESECL
yyyy 0001 0111	Y27	R	Performance Persistent Latch	#, #, #, #, #, #, #, #, #, #, #, #, RAISP, AISP, LOSSP, BSYNCP
yyyy 0001 1000	Y28	R	E-bit Error Count Latch	EEL15-8, EEL7-0
yyyy 0001 1001	Y29	R	BPV Error Count Latch	VEL15-8, VEL7-0
yyyy 0001 1010	Y2A	R	CRC-4 Error Count Latch	CEL15-8, CEL7-0
yyyy 0001 1011	Y2B	R	FAS Bit Error Count Latch FAS Error Count Latch	BEL7-0 FEL7-0
yyyy 0010 1100- yyyy 0010 1111	Y2C-Y2F	-	not used	not used
# indicates the unused bits in the register that may be any value if read see the Register Group Address Summary for an explanation of yyyy and Y				

Table 139 - Latched Status Register (R) Address (Y2X) Summary (E1)

16.2.2.4 Interrupt Status Registers Address Summary(Y3X)

Binary Address (A ₁₀ -A ₀)	Hex Address	R/W	Interrupt Status Register	Status Bits (B15 - B8 / B7 - B0)
1000 0011 0000	910	R	Vector 1	F3HI, F3NI, F3CI, F3SI, F2HI, F2NI, F2CI, F2SI, F1HI, F1NI, F1CI, F1SI, F0HI, F0NI, F0CI, F0SI
1000 0011 0001	911	R	Vector 2	F7HI, F7NI, F7CI, F7SI, F6HI, F6NI, F6CI, F6SI, F5HI, F5NI, F5CI, F5SI, F4HI, F4NI, F4CI, F4SI
	Y33	R	HDLC Interrupt Status	GAI,EOPDI,TEOPI,EOPRI,TXFLI,FAI,TXUNDERI, RXFFI,RXOVFLI
yyyy 0011 0100	Y34	R	Sync (Sync, CRC-4 Remote, Alarms, MAS and Phase)	# RCRCRI, RSLPI, YI, AUXPI, RAI, AISI, AIS16I, LOSSI, RCRC0I, RCRC1I, CEFSI, RFAILI, CSYNCI, MSYNCI, BSYNCI
yyyy 0011 0101	Y35	R	Counter (Counter Indication and Counter Overflow)	SLOI, 0, FEOI, FEII, BEOI, BEII, CEOI, CEII, VEOI, VEII, EEOI, EEII, PCOI, 0, PEOI, PEII
yyyy 0011 0110	Y36	R	National (CAS, National, CRC-4 Local and Timers)	Sa5VI, Sa6V3I, Sa6V2I, Sa6V1I, Sa6V0I, Sa6N8I, Sa6NI, SaNI, Sa5TI, SaTI, #, CALNI, T2I, T1I, ONESECI
yyyy 0011 0111- yyyy 0011 1111	Y37-Y3F	-	not used	not used

indicates the unused bits in the register that may be any value if read see the Register Group Address Summary for an explanation of yyyy and Y

Table 140 - Interrupt Status Register (R) Address Summary (E1)

16.2.2.5 Interrupt Mask Registers Address Summary(Y4X)

Binary Address (A ₁₀ -A ₀)	Hex Address	R/W	Interrupt Mask Register	Control Bits (B ₁₅ - B ₈ / B ₇ - B ₀)
yyyy 0100 0011	Y43	R	HDLC Interrupt Mask	GAIM,EOPDIM,TEOPIM,EOPRIM,TXFLIM,FAIM,TX UNDERIM,RXFFIM,RXOVFLIM
yyyy 0100 0100	Y44	R/W	Sync (Sync, CRC-4 Remote, Alarms, MAS and Phase)	CASRM, RCRCRM, RSLPM, YM, AUXPM, RAIM, AISM, AIS16M, LOSSM, RCRC0M, RCRC1M, CEFSM, RFAILM, CSYNCM, MSYNCM, BSYNCM
yyyy 0100 0101	Y45	R/W	Counter (Counter Indication and Counter Overflow)	SLOM, #M, FEOM, FEIM, BEOM, BEIM, CEOM, CEIM, VEOM, VEIM, EEOM, EEIM, PCOM, #, PEOM, PEIM
yyyy 0100 0110	Y46	R/W	National (CAS, National, CRC-4 Local and Timers)	Sa5VM, Sa6V3M, Sa6V2M, Sa6V1M, Sa6V0M, Sa6N8M, Sa6NM, SaNM, Sa5TM, SaTM, #, CALNM, T2M, T1M, ONESECM
yyyy 0100 0111- yyyy 0100 1111	Y47-Y4F	-	not used	not used
# indicates the unused bits in the register that may be any value if read see the Register Group Address Summary for an explanation of yyyy and Y				

Table 141 - Interrupt Mask Register (R/W) Address Summary (E1)

16.2.2.6 Transmit CAS Data Registers Address (Y50-Y6F) Summary

Binary Address (A ₁₀ -A ₀)	Hex Address	Register	Data Bits (Upper bits B15 - B4 unused, B3 - B0 are shown)
yyyy 0101 0000	Y50	not used	not used
yyyy 0101 0001	Y51	Channel 1 Transmit CAS Data	A1, B1, C1, D1
yyyy 0101 0010	Y52	Channel 2 Transmit CAS Data	A2, B2, C2, D2
yyyy 0101 0011	Y53	Channel 3 Transmit CAS Data	A3, B3, C3, D3
yyyy 0101 0100	Y54	Channel 4 Transmit CAS Data	A4, B4, C4, D4
yyyy 0101 0101	Y55	Channel 5 Transmit CAS Data	A5, B5, C5, D5
yyyy 0101 0110	Y56	Channel 6 Transmit CAS Data	A6, B6, C6, D6
yyyy 0101 0111	Y57	Channel 7 Transmit CAS Data	A7, B7, C7, D7
yyyy 0101 1000	Y58	Channel 8 Transmit CAS Data	A8, B8, C8, D8
yyyy 0101 1001	Y59	Channel 9 Transmit CAS Data	A9, B9, C9, D9
yyyy 0101 1010	Y5A	Channel 10 Transmit CAS Data	A10, B10, C10, D10
yyyy 0101 1011	Y5B	Channel 11 Transmit CAS Data	A11, B11, C11, D11
yyyy 0101 1100	Y5C	Channel 12 Transmit CAS Data	A12, B12, C12, D12
yyyy 0101 1101	Y5D	Channel 13 Transmit CAS Data	A13, B13, C13, D13
yyyy 0101 1110	Y5E	Channel 14 Transmit CAS Data	A14, B14, C14, D14
yyyy 0101 1111	Y5F	Channel 15 Transmit CAS Data	A15, B15, C15, D15
yyyy 0110 0000	Y60	not used	not used
yyyy 0110 0001	Y61	Channel 16 Transmit CAS Data	A16, B16, C16, D16
yyyy 0110 0010	Y62	Channel 17 Transmit CAS Data	A17, B17, C17, D17
yyyy 0110 0011	Y63	Channel 18 Transmit CAS Data	A18, B18, C18, D18
yyyy 0110 0100	Y64	Channel 19 Transmit CAS Data	A19, B19, C19, D19
yyyy 0110 0101	Y65	Channel 20 Transmit CAS Data	A20, B20, C20, D20
yyyy 0110 0110	Y66	Channel 21 Transmit CAS Data	A21, B21, C21, D21
yyyy 0110 0111	Y67	Channel 22 Transmit CAS Data	A22, B22, C22, D22
yyyy 0110 1000	Y68	Channel 23 Transmit CAS Data	A23, B23, C23, D23
yyyy 0110 1001	Y69	Channel 24 Transmit CAS Data	A24, B24, C24, D24
yyyy 0110 1010	Y6A	Channel 25 Transmit CAS Data	A25, B25, C25, D25
yyyy 0110 1011	Y6B	Channel 26 Transmit CAS Data	A26, B26, C26, D26
yyyy 0110 1100	Y6C	Channel 27 Transmit CAS Data	A27, B27, C27, D27
yyyy 0110 1101	Y6D	Channel 28 Transmit CAS Data	A28, B28, C28, D28
yyyy 0110 1110	Y6E	Channel 29 Transmit CAS Data	A29, B29, C29, D29
yyyy 0110 1111	Y6F	Channel 30 Transmit CAS Data	A30, B30, C30, D30

upper data bits (B15-4) are not used and may be any value if read
 see the Register Group Address Summary for an explanation of yyyy and Y
 Note that this registers are useable if the corresponding MPST bits in the per timeslot control are set.

Table 142 - Transmit CAS Data Register (R/W) Address (Y5X,Y6X) Summary (E1)

16.2.2.7 Receive CAS Data Registers Address (Y70-Y8F) Summary

Binary Address (A ₁₀ -A ₀)	Hex Address	Register	Data Bits (Upper bits B15 - B4 unused, B3 - B0 are shown)
yyyy 0111 0000	Y70	not used	not used
yyyy 0111 0001	Y71	Channel 1 Receive CAS Data	A1, B1, C1, D1
yyyy 0111 0010	Y72	Channel 2 Receive CAS Data	A2, B2, C2, D2
yyyy 0111 0011	Y73	Channel 3 Receive CAS Data	A3, B3, C3, D3
yyyy 0111 0100	Y74	Channel 4 Receive CAS Data	A4, B4, C4, D4
yyyy 0111 0101	Y75	Channel 5 Receive CAS Data	A5, B5, C5, D5
yyyy 0111 0110	Y76	Channel 6 Receive CAS Data	A6, B6, C6, D6
yyyy 0111 0111	Y77	Channel 7 Receive CAS Data	A7, B7, C7, D7
yyyy 0111 1000	Y78	Channel 8 Receive CAS Data	A8, B8, C8, D8
yyyy 0111 1001	Y79	Channel 9 Receive CAS Data	A9, B9, C9, D9
yyyy 0111 1010	Y7A	Channel 10 Receive CAS Data	A10, B10, C10, D10
yyyy 0111 1011	Y7B	Channel 11 Receive CAS Data	A11, B11, C11, D11
yyyy 0111 1100	Y7C	Channel 12 Receive CAS Data	A12, B12, C12, D12
yyyy 0111 1101	Y7D	Channel 13 Receive CAS Data	A13, B13, C13, D13
yyyy 0111 1110	Y7E	Channel 14 Receive CAS Data	A14, B14, C14, D14
yyyy 0111 1111	Y7F	Channel 15 Receive CAS Data	A15, B15, C15, D15
yyyy 1000 0000	Y80	not used	not used
yyyy 1000 0001	Y81	Channel 16 Receive CAS Data	A16, B16, C16, D16
yyyy 1000 0010	Y82	Channel 17 Receive CAS Data	A17, B17, C17, D17
yyyy 1000 0011	Y83	Channel 18 Receive CAS Data	A18, B18, C18, D18
yyyy 1000 0100	Y84	Channel 19 Receive CAS Data	A19, B19, C19, D19
yyyy 1000 0101	Y85	Channel 20 Receive CAS Data	A20, B20, C20, D20
yyyy 1000 0110	Y86	Channel 21 Receive CAS Data	A21, B21, C21, D21
yyyy 1000 0111	Y87	Channel 22 Receive CAS Data	A22, B22, C22, D22
yyyy 1000 1000	Y88	Channel 23 Receive CAS Data	A23, B23, C23, D23
yyyy 1000 1001	Y89	Channel 24 Receive CAS Data	A24, B24, C24, D24
yyyy 1000 1010	Y8A	Channel 25 Receive CAS Data	A25, B25, C25, D25
yyyy 1000 1011	Y8B	Channel 26 Receive CAS Data	A26, B26, C26, D26
yyyy 1000 1100	Y8C	Channel 27 Receive CAS Data	A27, B27, C27, D27
yyyy 1000 1101	Y8D	Channel 28 Receive CAS Data	A28, B28, C28, D28
yyyy 1000 1110	Y8E	Channel 29 Receive CAS Data	A29, B29, C29, D29
yyyy 1000 1111	Y8F	Channel 30 Receive CAS Data	A30, B30, C30, D30

upper data bits (B15-4) are not used and may be any value if read
see the Register Group Address Summary for an explanation of yyyy and Y

Table 143 - Receive CAS Data Register (R) Address (Y7X,Y8X) Summary (E1)

16.2.2.8 Timeslot 0-31 Control Registers Address (Y90-YAF) Summary

Binary Address (A ₁₀ -A ₀)	Hex Address	Register	Control Bits (Upper byte B15 - B8 unused, B8 - B0 are shown)
yyyy 1001 0000	Y90	Timeslot 0 Control	Set to 0
yyyy 1001 0001	Y91	Timeslot 1 Control	RADI1,MPDR1,MPDR1,CASS1, TADI1, RTSL1, LTSL1, TTST1, RRST1, MPDT1, #
yyyy 1001 0010	Y92	Timeslot 2 Control	RADI2,MPDR2,MPDR2,CASS2, TADI2, RTSL2, LTSL2, TTST2, RRST2, MPDT2, #
yyyy 1001 0011	Y93	Timeslot 3 Control	RADI3,MPDR3,MPDR3,CASS3,T ADI3, RTSL3, LTSL3, TTST3, RRST3, MPDT3, #
yyyy 1001 0100	Y94	Timeslot 4 Control	RADI4,MPDR4,MPDR4,CASS4, TADI4, RTSL4, LTSL4, TTST4, RRST4, MPDT4, #
yyyy 1001 0101	Y95	Timeslot 5 Control	RADI5,MPDR5,MPDR5,CASS5, TADI5, RTSL5, LTSL5, TTST5, RRST5, MPDT5, #
yyyy 1001 0110	Y96	Timeslot 6 Control	RADI6,MPDR6,MPDR6,CASS6, TADI6, RTSL6, LTSL6, TTST6, RRST6, MPDT6, #
yyyy 1001 0111	Y97	Timeslot 7 Control	RADI7,MPDR7,MPDR7,CASS7, TADI7, RTSL7, LTSL7, TTST7, RRST7, MPDT7, #
yyyy 1001 1000	Y98	Timeslot 8 Control	RADI8,MPDR8,MPDR8,CASS8, TADI8, RTSL8, LTSL8, TTST8, RRST8, MPDT8, #
yyyy 1001 1001	Y99	Timeslot 9 Control	RADI9,MPDR9,MPDR9,CASS9, TADI9, RTSL9, LTSL9, TTST9, RRST9, MPDT9, #
yyyy 1001 1010	Y9A	Timeslot 10 Control	RADI10,MPDR10,MPDR10,CASS10,T ADI10, RTSL10, LTSL10, TTST10, RRST10, MPDT10, #
yyyy 1001 1011	Y9B	Timeslot 11 Control	RADI11,MPDR11,MPDR11,CASS11,T ADI11, RTSL11, LTSL11, TTST11, RRST11, MPDT11, #
yyyy 1001 1100	Y9C	Timeslot 12 Control	RADI12,MPDR12,MPDR12,CASS12, TADI12, RTSL12, LTSL12, TTST12, RRST12, MPDT12, #
yyyy 1001 1101	Y9D	Timeslot 13 Control	RADI13,MPDR13,MPDR13,CASS13, TADI13, RTSL13, LTSL13, TTST13, RRST13, MPDT13, #
yyyy 1001 1110	Y9E	Timeslot 14 Control	RADI14,MPDR14,MPDR14,CASS14, TADI14, RTSL14, LTSL14, TTST14, RRST14, MPDT14, #
yyyy 1001 1111	Y9F	Timeslot 15 Control	RADI15,MPDR15,MPDR15,CASS15, TADI15, RTSL15, LTSL15, TTST15, RRST15, MPDT15, #
yyyy 1010 0000	YA0	Timeslot 16 Control	RADI16,MPDR16,MPDR16,CASS16, TADI16, RTSL16, LTSL16, TTST16, RRST16, MPDT16, #
yyyy 1010 0001	YA1	Timeslot 17 Control	RADI17,MPDR17,MPDR17,CASS17, TADI17, RTSL17, LTSL17, TTST17, RRST17, MPDT17, #
yyyy 1010 0010	YA2	Timeslot 18 Control	RADI18,MPDR18,MPDR18,CASS18, TADI18, RTSL18, LTSL18, TTST18, RRST18, MPDT18, #
yyyy 1010 0011	YA3	Timeslot 19 Control	RADI19,MPDR19,MPDR19,CASS19, TADI19, RTSL19, LTSL19, TTST19, RRST19, MPDT19, #

Table 144 - Timeslot 0-31 Control Register (R/W) Address (Y9X, YAX) Summary (E1)

Binary Address (A ₁₀ -A ₀)	Hex Address	Register	Control Bits (Upper byte B15 - B8 unused, B8 - B0 are shown)
yyyy 1010 0100	YA4	Timeslot 20 Control	RADI20,MPDR20,MPDR20,CASS20, TADI20, RTSL20, LTSL20, TTST20, RRST20, MPDT20, #
yyyy 1010 0101	YA5	Timeslot 21 Control	RADI21,MPDR21,MPDR21,CASS21, TADI21, RTSL21, LTSL21, TTST21, RRST21, MPDT21, #
yyyy 1010 0110	YA6	Timeslot 22 Control	RADI22,MPDR22,MPST22,CASS22, TADI22, RTSL22, LTSL22, TTST22, RRST22, MPDT22, #
yyyy 1010 0111	YA7	Timeslot 23 Control	RADI23,MPDT23,MPDR23,CASS23, TADI23, RTSL23, LTSL23, TTST23, RRST23, MPDT23, #
yyyy 1010 1000	YA8	Timeslot 24 Control	RADI24,MPDT24,MPDR24,CASS24, TADI24, RTSL24, LTSL24, TTST24, RRST24, MPDT24, #
yyyy 1010 1001	YA9	Timeslot 25 Control	RADI25,MPDT25,MPDR25,CASS25, TADI25, RTSL25, LTSL25, TTST25, RRST25, MPDT25, #
yyyy 1010 1010	YAA	Timeslot 26 Control	RADI26,MPDT26,MPDR26,CASS26, TADI26, RTSL26, LTSL26, TTST26, RRST26, MPDT26, #
yyyy 1010 1011	YAB	Timeslot 27 Control	RADI27,MPDT27,MPDR27,CASS27, TADI27, RTSL27, LTSL27, TTST27, RRST27, MPDT27, #
yyyy 1010 1100	YAC	Timeslot 28 Control	RADI28,MPDT28,MPDR28,CASS28, TADI28, RTSL28, LTSL28, TTST28, RRST28, MPDT28, #
yyyy 1010 1101	YAD	Timeslot 29 Control	RADI29,MPDT29,MPDR29,CASS29, TADI29, RTSL29, LTSL29, TTST29, RRST29, MPDT29, #
yyyy 1010 1110	YAE	Timeslot 30 Control	RADI30,MPDT30,MPDR30,CASS30, TADI30, RTSL30, LTSL30, TTST30, RRST30, MPDT30, #
yyyy 1010 1111	YAF	Timeslot 31 Control	RADI31,MPDT31,MPDR31,CASS31,TADI31, RTSL31, LTSL31, TTST31, RRST31, MPDT31, #
upper data byte (B15-8) is not used and may be any value if read # indicates the unused bits in the register that may be any value if read see the Register Group Address Summary for an explanation of yyyy and Y			

Table 144 - Timeslot 0-31 Control Register (R/W) Address (Y9X, YAX) Summary (E1)

16.2.2.9 Transmit National Bit Data Register(R/W) Address(YB0 to YB4) Summary

Binary Address (A ₁₀ -A ₀)	Hex Address	Register	Data Bits (Upper byte B15 - B8 unused, B7 - B0 are shown)
yyyy 1111 1000	YB0	Transmit National Bits TN0 (Sa4)	TN0F1, TN0F3, TN0F5, TN0F7, TN0F9, TN0F11, TN0F13, TN0F15
yyyy 1111 1001	YB1	Transmit National Bits TN1 (Sa5)	TN1F1, TN1F3, TN1F5, TN1F7, TN1F9, TN1F11, TN1F13, TN1F15
yyyy 1111 1010	YB2	Transmit National Bits TN2 (Sa6)	TN2F1, TN2F3, TN2F5, TN2F7, TN2F9, TN2F11, TN2F13, TN2F15
yyyy 1111 1011	YB3	Transmit National Bits TN3 (Sa7)	TN3F1, TN3F3, TN3F5, TN3F7, TN3F9, TN3F11, TN3F13, TN3F15
yyyy 1111 0100	YB4	Transmit National Bits TN4 (Sa8)	TN4F1, TN4F3, TN4F5, TN4F7, TN4F9, TN4F11, TN4F13, TN4F15
yyyy 1011 0101- yyyy 1011 1111	YB5- YBF	not used	not used
upper data byte (B15-8) is not used and may be any value if read see the Register Group Address Summary for an explanation of yyyy and Y			

Table 145 - Transmit National Bits Data Registers (R/W) Address (YFX) Summary (E1)

16.2.2.10 Receive National Bit Data Register(R/W) Address(YC0 to YC4) Summary

Binary Address (A ₁₀ -A ₀)	Hex Address	Register	Data Bits (Upper byte B15 - B8 unused, B7 - B0 are shown)
yyyy 1111 1000	YC0	Receive National Bits RN0 (Sa4)	RN0F1, RN0F3, RN0F5, RN0F7, RN0F9, RN0F11, RN0F13, RN0F15
yyyy 1111 1001	YC1	Receive National Bits RN1 (Sa5)	RN1F1, RN1F3, RN1F5, RN1F7, RN1F9, RN1F11, RN1F13, RN1F15
yyyy 1111 1010	YC2	Receive National Bits RN2 (Sa6)	RN2F1, RN2F3, RN2F5, RN2F7, RN2F9, RN2F11, RN2F13, RN2F15
yyyy 1111 1011	YC3	Receive National Bits RN3 (Sa7)	RN3F1, RN3F3, RN3F5, RN3F7, RN3F9, RN3F11, RN3F13, RN3F15
yyyy 1111 0100	YC4	Receive National Bits RN4 (Sa8)	RN4F1, RN4F3, RN4F5, RN4F7, RN4F9, RN4F11, RN4F13, RN4F15
yyyy 1011 0101- yyyy 1011 1111	YC5- YCF	not used	not used
upper data byte (B15-8) is not used and may be any value if read see the Register Group Address Summary for an explanation of yyyy and Y			

Table 146 - Transmit National Bits Data Registers (R/W) Address (YFX) Summary (E1)

16.2.3 Master Control Registers (Y00 - Y09) Bit Functions

Tables 147 to 157 describe the bit functions of each of the Master Control Registers in the MT9072 in E1 Mode.

Each register is repeated for each of the 8 framers. Framer 0 is addressed with Y=0, Framer 1 with Y=1, Framer 2 with Y=2 and so on up to Framer 7 with Y=7 (where Y represents the 4 most significant address bits (MSB) A11-A8). In addition, a simultaneous write to all 8 framers is possible by setting the MSB address to Y=8 (1000).

A (0), (1) or (#) in the "Name" column of these tables indicates the state of the data bits after a reset ($\overline{\text{RESET}}$, RSTC or RST). The (#) indicates that a (0) or (1) is possible.

Bit	Name	Functional Description
15	IMA	Inverse Mux for ATM Mode. Setting this bit high the I/O ports to allow for easy connection to one of the Zarlink IMA devices such as the MT90220. DSTi becomes a serial 2.048 data stream. C4b becomes a 4.096 MHz clock that clocks DSTi as the St-Bus. RXFPB becomes a framing pulse that flags the E1 stream coming from the pin DSTo. The data from DSTo is clocked out on RXDLC. Set this pin low for all other applications. Note that signalling operations CSTi/CSTo do not function with the IMA Mode. The global control register 900 bit CK1 is ignored for this framer. 8.192 Mbit/s backplane mode is not supported if IMA mode is selected on any one framer.
14	ASEL (0)	AIS Select. This bit selects the criteria on which the detection of a valid alarm indication signal (AIS=1 of register address Y11) is based. If zero, the criteria is fewer than three zeros in a two frame period (512 bits). If one, the criteria is fewer than three zeros in each of two consecutive double-frame periods (512 bits per double-frame).
13	ARAI (0)	Automatic Remote Alarm Indication (RAI) Operation. This bit determines the source for the Remote Alarm Indication bit (the A bit) of the transmit PCM30 signal (time-slot 0 bit 3 of NFAS frames). If zero, the source for the A bit is the RAI bit of the Timer and Alarm Status Register (address Y11), and consequently, will change automatically. That is, A=0 when basic synchronization has been acquired (RAI=0), and A=1 when basic synchronization has not been acquired (RAI=1). If the ARAI bit is set to one, the A bit is controlled through the TALM control bit (register address Y00).
12	TALM (0)	Transmit Remote Alarm. This bit is the source for the Remote Alarm Indication bit (the A bit) of the transmit PCM30 signal (timeslot 0 bit 3 of NFAS frames) when the ARAI control bit (register address Y00) is set to one. The TALM bit is used to signal an alarm to the remote end of the PCM30 link (one - alarm, zero - normal).
11	TAIS (0)	Transmit Alarm Indication Signal. If one, an all ones signal is transmitted in all timeslots except zero and 16. If zero, timeslots function normally.
10	TAIS0 (0)	Transmit AIS Timeslot Zero. If one, an all ones signal is transmitted in timeslot zero. If zero, timeslot zero functions normally.
9	TAI16 (0)	Transmit AIS Timeslot 16. If one, an all ones signal is transmitted in timeslot 16. If zero, timeslot functions normally.
8	TE (0)	Transmit E bits. If zero, and CRC-4 synchronization is achieved, the PCM30 link E-bits transmit the received CRC-4 comparison results to the distant end of the link, as per G.703. If zero, and CRC-4 synchronization is lost, the E-bits transmit zero. If one, and CRC-4 synchronization is lost the transmit E-bits will be one.
7	TIU0 (0)	Transmit International Use Zero. This bit is transmitted on the PCM30 2048kb/s link in bit position one of time-slot 0 of all the frame-alignment signal (FAS) frames when CRC-4 operation is disabled ($\overline{\text{CSYN}}=1$ of register address Y00). The TIU0 bit is reserved for international use and should normally be kept at one. If CRC-4 operation is enabled ($\overline{\text{CSYN}}=0$), this bit is ignored.

Table 147 - Alarm and Framing Control Register Y00 (R/W Address Y00) (E1)

Bit	Name	Functional Description
6	TIU1 (1)	Transmit International Use One. This bit is transmitted on the PCM 30 2048kb/s link in bit position one of timeslot 0 of all the Non-Frame Alignment Signal (NFAS) frames when CRC-4 operation is disabled ($\overline{\text{CSYN}}=1$ of register address Y00). The TIU1 bit is reserved for international use and should normally be kept at one. If CRC-4 operation is enabled ($\overline{\text{CSYN}}=0$), this bit is ignored.
5	$\overline{\text{CSYN}}$ (0)	CRC-4 Synchronization. The $\overline{\text{CSYN}}$ bit in combination with $\overline{\text{AUTC}}$ determines the enabling or disabling of the CRC functions for timeslot 0. If one and $\overline{\text{AUTC}}$ (register address Y00) is one the first bits of time-slot 0 for the transmitter are used as international use bits and are programmed by the TIU0 and TIU1bits (register address Y00). If $\overline{\text{AUTC}}$ is a zero, the CRC-4 calculated bits are inserted in the FAS frames as shown in Table 12. Also if $\overline{\text{AUTC}}$ is a one, the $\overline{\text{CSYN}}$ has to be low for the CRC-4 bits to be inserted in the FAS frames. The transmit transparent bit overrides the function of this bit for the transmitter. On the receiver side, if $\overline{\text{AUTC}}$ is 1 and $\overline{\text{CSYN}}$ is 0 then more than 914 CRC errors in 1 second will cause a resynchronization and search for a basic frame synchronization. If $\overline{\text{AUTC}}$ is a 1 and $\overline{\text{CSYN}}$ is 1 than CRC errors are ignored. If $\overline{\text{AUTC}}$ is a zero than more than 914 CRC errors in 1 second will result in basic frame reframe.
4	REFRM (0)	Reframe. A one-to-zero transition of this bit results in the execution of the reframing function (the search for a new basic frame position). The basic frame alignment pattern is x0011011 in timeslot 0 of alternate frames.
3	$\overline{\text{AUTC}}$ (0)	Automatic CRC-interworking. If zero, automatic CRC-interworking is activated. If one, it is deactivated. See Framing Algorithm section, Table 13 for details.
2	CRCM (0)	CRC-4 Modification. If one, the transmit CRC-4 remainder is modified when the device is in transmit transparent mode ($\text{TxTRS}=1$ of register address Y03) in accordance with the local datalink. The received CRC-4 remainder from the originating node is modified to reflect only the changes in the local transmit DataLink. If zero, time-slot 0 data from DSTi will not be modified in transmit transparent mode. This feature can used for intermediate nodes where 2 end nodes are communicating for framing/signalling and 2 intermediate nodes are sending datalink information in accordance with appendix C of G.706.
1	$\overline{\text{AUTY}}$ (0)	Automatic Y-Bit Operation. This bit determines the source for the Remote Multiframe Alarm Indication bit (the Y bit) of the transmit PCM30 signal (time-slot 16 bit 6 of every frame 0 of the CAS multiframe). If zero, the source for the Y bit is the Y bit of the Receive Alignment Signals Status Register (address Y12), and consequently, will change automatically. That is, $Y=0$ when multiframe alignment has been acquired ($Y=0$ of status register), and $Y=1$ when multiframe alignment has not been acquired ($Y=1$ of status register). If the $\overline{\text{AUTY}}$ bit is set to one, the Y bit is controlled through the Y bit of the CAS Control and Data Register (address Y05).
0	MFRF (0)	Multiframe Reframe. If one, for at least one frame, and then cleared, the selected framer (Y) will initiate a search for a new signalling multiframe position. Reframing function is activated on the one-to-zero transition of the MFRF bit. The signalling multiframe algorithm will align to the first multiframe alignment signal pattern ($\text{MFAS} = 0000$) it receives in the most significant nibble of channel 16 (status register address Y10 bit $\overline{\text{MSYNC}}$ is zero). Signalling multiframe will be lost when two consecutive multiframe are received in error.

Table 147 - Alarm and Framing Control Register Y00 (R/W Address Y00) (E1)

Bit	Name	Functional Description
15-14	#	not used.
13	L32Z (0)	Digital Loss of Signal Selection. If one, the threshold for digital loss of signal is 32 successive zeros. If zero, the threshold is set to 192 successive zeros.
12	ADSEQ (0)	Digital Milliwatt or Digital Test Sequence. If one, the A-law digital milliwatt analog test sequence will be selected by the Per Timeslot Control bits TTSTn and RTSTn (register address Y90 to YAF). If zero, the PRBS 2 ¹⁵ -1 bit error rate test sequence will be selected by the Per Timeslot Control bits TTSTn and RTSTn. The PRBS generator is reset whenever this bit is set to 1.
11	DLBK (0)	Digital Loopback. If one, all timeslots of DSTi are connected to DSTo on the PCM30 side of the selected framer (Y). If zero, this feature is disabled. See Loopbacks section.
10	RLBK (0)	Remote Loopback. If one, all timeslots received on RPOS/RNEG are connected to TPOS/TNEG on the PCM30 side of the selected framer (Y). If zero, this feature is disabled. See Loopbacks section.
9	SLBK (0)	ST-BUS Loopback. If one, all timeslots of DSTi are connected to DSTo on the ST-BUS side of the selected framer (Y). If zero, this feature is disabled. See Loopbacks section.
8	PLBK (0)	Payload Loopback. If one, all timeslots received on RPOS/RNEG are connected to TPOS/TNEG on the ST-BUS side(DSTo to DSTi) of the selected framer (Y) (this excludes time-slot 0). Hence the data passes through the receiver and output to DSTo. This DSTo data is looped back to DSTi which is transmitted to TPOS/TNEG by the transmitter. If zero, this feature is disabled. See Loopbacks section.
7	E1 (0)	E1 Error Insertion. A zero-to-one transition of this bit inserts a single E1 error into the transmit PCM30 data (bit position 1 of frame 13 of the CRC-4 Multiframe). A one, zero or one-to-zero transition has no function.
6	E2 (0)	E2 Error Insertion. A zero-to-one transition of this bit inserts a single E2 error into the transmit PCM30 data (bit position 1 of frame 15 of the CRC-4 Multiframe). A one, zero or one-to-zero transition has no function.
5	BVE (0)	Bipolar Violation Error Insertion. A zero-to-one transition of this bit inserts a single bipolar violation error into the transmit PCM30 data. A one, zero or one-to-zero transition has no function.
4	CRCE (0)	CRC-4 Error Insertion. A zero-to-one transition of this bit inserts a single CRC-4 error into the transmit PCM30 data. A one, zero or one-to-zero transition has no function.
3	FASE (0)	Frame Alignment Signal Error Insertion. A zero-to-one transition of this bit inserts a single error into the timeslot zero frame alignment signal of the transmit PCM30 data. A one, zero or one-to-zero transition has no function.
2	NFSE (0)	Non-frame Alignment Signal Error Insertion. A zero-to-one transition of this bit inserts a single error into bit two of the timeslot zero non-frame alignment signal of the transmit PCM30 data. A one, zero or one-to-zero transition has no function.
1	LOSE (0)	Loss of Signal Error Insertion. If one, the selected framer (Y) transmits an all zeros signal (no pulses) in every PCM30 timeslot, and, the HDB3 control bit (reg address Y02) has no effect. If zero, data is transmitted normally.
0	PERR (0)	Payload Error Insertion. A zero-to-one transition of this bit inserts a single error in the transmit payload. A one, zero or one-to-zero transition has no function.

Table 148 - Test, Error and Loopback Control Register (R/W Address Y01) (E1)

Bit	Name	Functional Description												
15 14	COD1 COD0 (1 0)	Line Coding. These two coding select bits determine the transmit and receive coding options as follows. See Figures 64 to 67. COD1 COD0 Function <table border="0"> <tr> <td>0</td> <td>0</td> <td>RZ (Return to Zero, Dual Rail)</td> </tr> <tr> <td>0</td> <td>1</td> <td>NRZ (Non-return to Zero, Single Rail)</td> </tr> <tr> <td>1</td> <td>0</td> <td>NRZB (Non-return to Zero, Dual Rail)</td> </tr> <tr> <td>1</td> <td>1</td> <td>No function</td> </tr> </table>	0	0	RZ (Return to Zero, Dual Rail)	0	1	NRZ (Non-return to Zero, Single Rail)	1	0	NRZB (Non-return to Zero, Dual Rail)	1	1	No function
0	0	RZ (Return to Zero, Dual Rail)												
0	1	NRZ (Non-return to Zero, Single Rail)												
1	0	NRZB (Non-return to Zero, Dual Rail)												
1	1	No function												
13	RHDB3 (0)	RHDB3 (High Density Bipolar 3) encoding. If zero, HDB3 decoding is enabled in the receive direction. If one, AMI (Alternate Mark Inversion) signal without HDB3 decoding is enabled in the transmit direction.												
12	T2OP (0)	T2o Polarity. If one, the TxCL pin will output a 2.048MHz clock whose rising edge is in the center of the transmitted PCM30 bit cell at the TPOS and TNEG transmit pins. This clock is equivalent to the internal ST-BUS C2 clock. If zero, the TxCL pin will output a 2.048MHz clock whose falling edge is in the center of the transmitted PCM30 bit cell at the TPOS and TNEG transmit pins. This clock is equivalent to the internal ST-BUS C2 clock.												
11	MFBE (0)	Transmit Multiframe Boundary Enable. If one, the $\overline{\text{TxMF}}$ pin will be enabled. If zero, the $\overline{\text{TxMF}}$ pin will be disabled. See the $\overline{\text{TxMF}}$ pin description.												
10	Tx8KEN	Transmit 8 KHz Enable. If one, the pin $\overline{\text{RxMF}}$ transmits a positive 8 KHz frame pulse synchronous with the serial data stream transmit on TPOS/TNEG. If zero, the pin $\overline{\text{RxMF}}$ transmits a negative frame pulse synchronous with the multiframe boundary of data coming out of DSTo.												
9	SPND (0)	Suspend Interrupts. If zero, the selected framers contribution to the $\overline{\text{IRQ}}$ pin output will be a high impedance state, but all interrupt status registers will continue to be updated. If one, the selected framers contribution to the $\overline{\text{IRQ}}$ output will be normal operation.												
8	INTA (0)	Interrupt Acknowledge. If zero, all interrupt and latched status registers are cleared and the selected framers contribution to the $\overline{\text{IRQ}}$ pin output will be a high impedance state. If one, all interrupt status registers and the selected framers contribution to the $\overline{\text{IRQ}}$ output will be normal operation.												
7	CLKE (0)	Clock Edge. If one then the NRZ data (RPOS/RNEG) is sampled on the rising edge of EXCLi and transmitted on the falling edge of EXCLi. This selection is only applicable in NRZ mode.												
6	THDB3 (0)	THDB3 (High Density Bipolar 3) Encoding. If zero, HDB3 encoding is enabled in the transmit direction. If one, AMI (Alternate Mark Inversion) signal without HDB3 encoding is enabled in the transmit direction.												
5	RxBFE (0)	Receive Basic Frame Enable. If one, the $\overline{\text{RxBF}}$ pin operates normally. If zero, the $\overline{\text{RxBF}}$ pin is low.												
4	RxDO (0)	Receive DSTo All Ones. If one, the DSTo pin operates normally. If zero, all timeslots (0-31) of DSTo are set to one.												
3	RxCO (0)	Receive CSTo All Ones. If one, the CSTo pin operates normally. If zero, all timeslots (0-31) of CSTo are set to one.												
2	CSToE (0)	Output CSTo Enable. If one, the CSTo pin operates normally. If zero, CSTo will be at high impedance. In 8.192 Mbit/s mode all CSToE for all framers have to be 0 to obtain high impedance.												
1	DSToE (0)	Output DSTo Enable. If one, the DSTo pin operates normally. If zero, DSTo will be at high impedance.												

Table 149 - Interrupts and I/O Control Register (R/W Address Y02) (E1)

Bit	Name	Functional Description
0	MFSEL (0)	Multiframe Select. This bit determines which receive multiframe signal (CRC-4 or signaling) the frame pulse at the RxMF pin is aligned with. If zero, the frame pulse at the RxMF pin is aligned with the receive channel associated signaling (CAS) multiframe; if one, the receive CRC-4 multiframe. See Figures 55 & 58.

Table 149 - Interrupts and I/O Control Register (R/W Address Y02) (E1)

Bit	Name	Functional Description
15-7	#	not used.
6	ELAS (0)	Elastic Buffer Enable. When this bit is set to one, the data at DSTo is a 2.048Mb/s serial output stream which contains all 32 timeslots of the received PCM30 link data after HDB3 decoding. This data does not pass through the elastic buffer and is clocked out with the falling edge of EXCLi. The data at the DSTo pin is identical to the data at the RXDL pin. When this bit is set to zero, the elastic buffer is enabled, and DSTo operates synchronously with the clock at the CKi pin. Note that only RXDLC or the EXCL can be used to clock DSTo data and DSTo data has no relationship to CKi when ELAS is 1.
5	ACCLR (0)	Automatic Counter Clear. When this bit is set to one, all non-latched status counters (address Y15 to Y1A) are cleared automatically by the one second timer bit ONESEC (address Y11) immediately following the counter latch operation (address Y25 to Y2B). If zero, all non-latched status counters operate normally.
4	RxTRS (0)	Receive Transparent Mode. If one, the framing function is disabled on the receive side. Data coming from the receive line passes through the slip buffer and drives DSTo with an arbitrary alignment. When zero, the receive framing function operates normally.
3	TxTRS (0)	Transmit Transparent Mode. If one, the MT9072 is in transmit transparent mode where no framing or signaling is imposed on data transmitted from DSTi onto the PCM30 line. In other words, timeslot 0 and timeslot 16 data on the transmit PCM30 link is sourced from the DSTi input. If zero, the MT9072 is in termination mode.
2	CSIG (0)	CCS and CAS signaling. If one, the MT9072 is in Common Channel signaling (CCS) mode. If zero, the MT9072 is in Channel Associated signaling (CAS) mode.
1	CNCLR (0)	Counter Clear. When this bit is changed from zero to one, all non-latched status counters (address Y15 to Y1A) are cleared. If zero, all non-latched status counters operate normally.
0	RST (0)	Reset. When this bit is changed from zero to one, the selected framer (Y) will reset to its default mode. See the Reset Operation section for the default settings.

Table 150 - DL, CCS, CAS and Other Control Register (R/W Address Y03) (E1)

Bit	Name	Functional Description
15-2	#	not used.
1-0	SIP1-0	Signaling Interrupt Period. These 2 bits determine the signaling Interrupt period due to the Receive signaling changes. This 2 bits determine the duration of the signaling interrupt bit CASRI(Y36). 00 2 msec Period 01 8 msec Period 10 16 msec Period

Table 151 - Signaling Period Interrupt Word (R/W Address Y04) (E1)

Bit	Name	Functional Description
15-12	#	not used.
11	RFL (0)	Receive Signaling Freeze due to Loss. If one, the receive signaling is frozen if a receive loss of signal is detected. The freeze is cleared upon clearance of Loss.
10	DBNCE (0)	Debounce Select. This bit selects the receive CAS debounce period. If one, 14 ms of debounce is used. There may be as much as 2 ms added to this duration because the state change of the signaling equipment is not synchronous with the PCM30 signaling multiframe. If zero, no debounce is used.
9,8	(00)	not used.
7 6 5 4	TMA1 TMA2 TMA3 TMA4 (0000)	Transmit Multiframe Alignment Bits One to Four. These bits are transmitted on the PCM30 link, in the Multiframe Alignment Signal (MFAS) positions (one to four of timeslot 16) of frame zero of every Channel Associated signaling (CAS) multiframe. These bits are used by the far end to identify specific frames of a CAS multiframe. TMA1-4 = 0000 for normal operation.
3	X1 (1)	Transmit Non-Multiframe Alignment Signal (NMAS) Spare Bit. This bit is transmitted on the PCM30 link in bit position five of timeslot 16 of frame zero of every signaling multiframe. X1 is normally set to one.
2	Y (1)	Transmit Remote Multiframe Alarm Signal. This bit is transmitted on the PCM30 link in bit position six of timeslot 16 of frame zero of every signaling multiframe when control bit <u>AUTY</u> (register address Y00) is set to one. The Y bit is used to indicate the loss of multiframe alignment to the remote end of the link. If one, loss of multiframe alignment; if zero, multiframe alignment acquired.
1 0	X2 X3 (11)	Transmit Non-Multiframe Alignment Signal (NMAS) Spare Bits. These bits are transmitted on the PCM30 link in bit positions seven and eight respectively, of timeslot 16 of frame zero of every signaling multiframe. X2 and X3 are normally set to one.

Table 152 - CAS Control and Data Register (R/W Address Y05) (E1)

Bit	Name	Functional Description
15-12	#	not used.
11-7	HCH4-0 (0)	HDLC Channel 4-0. This 5 bit number specifies the channel time HDLC will be attached to if enabled. Channel 1 is the first channel in the frame. Channel 31 is the last channel available in a E1 frame. If enabled in a channel, HDLC data will be substituted for data from DSTi on the transmit side. Receive data is extracted from the incoming line data before the elastic buffer and decoded by the HDLC receiver. This bits are relevant if HPAYSEL is set.
6	HPAYSEL (0)	HDLC Payload Select. Set this bit to 1 to attach HDLC0 to a payload timeslot, if zero it is attached to the Facility data link in Timeslot 0 in accordance with selections in Y08.
5-3	#	not used
2	TS31E (0)	Time Slot 31 CST Enable. If one, the transmit PCM30 link timeslot 31 data will be sourced from a CSTi timeslot as selected by control bits 31C4 to 31C0 of register address Y07. And, the receive PCM30 link timeslot 31 data will be sourced to both DSTo timeslot 31 and to the above selected CSTo timeslot. This feature is used to link PCM30 CCS data to an external HDLC device through the CSTo and CSTi pins. If zero, the transmit PCM30 link timeslot 31 data will be sourced from DSTi timeslot 31. And, the receive PCM30 link timeslot 31 data will be sourced to DSTo timeslot 31 only. CCS (CSIG =1 of register address Y03) must be selected for these operations to be valid.
1	TS16E (0)	Time Slot 16 CST Enable. If one, the transmit PCM30 link timeslot 16 data will be sourced from a CSTi timeslot as selected by control bits 16C4 to 16C0 of register address Y07. And, the receive PCM30 link timeslot 16 data will be sourced to both DSTo timeslot 16 and to the above selected CSTo timeslot. This feature is used to link PCM30 CCS data to an external HDLC device through the CSTo and CSTi pins. If zero, the transmit PCM30 link timeslot 16 data will be sourced from DSTi timeslot 16. And, the receive PCM30 link timeslot 16 data will be sourced to DSTo timeslot 16 only. CCS (CSIG=1 of register address Y03) must be selected for these operations to be valid.
0	TS15E (0)	Time Slot 15 CST Enable. If one, the transmit PCM30 link timeslot 15 data will be sourced from a CSTi timeslot as selected by control bits 15C4 to 15C0 of register address Y07. And, the receive PCM30 link timeslot 15 data will be sourced to both DSTo timeslot 15 and to the above selected CSTo timeslot. This feature is used to link PCM30 CCS data to an external HDLC device through the CSTo and CSTi pins. If zero, the transmit PCM30 link timeslot 15 data will be sourced from DSTi timeslot 15. And, the receive PCM30 link timeslot 15 data will be sourced to DSTo timeslot 15 only. CCS (CSIG=1 of register address Y03) must be selected for these operations to be valid.

Table 153 - HDLC & CCS ST-BUS Control Register (R/W Address Y06) (E1)

Bit	Name	Functional Description																																										
15	#	not used.																																										
14 13 12 11 10	31C4 31C3 31C2 31C1 31C0 (11111)	<p>Timeslot 31 CST Map Bits. The selection of these bits results in a mapping of the transmit PCM30 timeslot 31, from a specific CSTi timeslot; and similarly, maps receive PCM30 timeslot 31, to a specific CSTo timeslot. PCM30 timeslot 31 data is mapped to/from CST channel n (n=0 to 31), where n is the BCD (Binary Coded Decimal) equivalent of 31C4 to 31C0 with 31C4 being the most significant bit.</p> <table border="1"> <thead> <tr> <th colspan="5">Bit Settings</th> <th>Selected CST Timeslot</th> </tr> <tr> <th>31C4</th> <th>31C3</th> <th>31C2</th> <th>31C1</th> <th>31C0</th> <th></th> </tr> </thead> <tbody> <tr> <td>0</td> <td>0</td> <td>0</td> <td>0</td> <td>0</td> <td>0</td> </tr> <tr> <td>0</td> <td>0</td> <td>0</td> <td>0</td> <td>1</td> <td>1</td> </tr> <tr> <td>0</td> <td>0</td> <td>0</td> <td>1</td> <td>0</td> <td>2</td> </tr> <tr> <td></td> <td></td> <td>etc.</td> <td></td> <td></td> <td></td> </tr> <tr> <td>1</td> <td>1</td> <td>1</td> <td>1</td> <td>1</td> <td>31</td> </tr> </tbody> </table> <p>CCS (CSIG=1 of register address Y03) and CST (TS31E=1 of register address Y06) must be selected for these operations to be valid.</p>	Bit Settings					Selected CST Timeslot	31C4	31C3	31C2	31C1	31C0		0	0	0	0	0	0	0	0	0	0	1	1	0	0	0	1	0	2			etc.				1	1	1	1	1	31
Bit Settings					Selected CST Timeslot																																							
31C4	31C3	31C2	31C1	31C0																																								
0	0	0	0	0	0																																							
0	0	0	0	1	1																																							
0	0	0	1	0	2																																							
		etc.																																										
1	1	1	1	1	31																																							
9 8 7 6 5	16C4 16C3 16C2 16C1 16C0 (10000)	<p>Timeslot 16 CST Map Bits. The selection of these bits results in a mapping of the transmit PCM30 timeslot 16, from a specific CSTi timeslot; and similarly, maps receive PCM30 timeslot 16, to a specific CSTo timeslot. PCM30 timeslot 16 data is mapped to/from CST channel n (n=0 to 31), where n is the BCD equivalent of 16C4 to 16C0 with 16C4 being the most significant bit.</p> <table border="1"> <thead> <tr> <th colspan="5">Bit Settings</th> <th>Selected CST Timeslot</th> </tr> <tr> <th>16C4</th> <th>16C3</th> <th>16C2</th> <th>16C1</th> <th>16C0</th> <th></th> </tr> </thead> <tbody> <tr> <td>0</td> <td>0</td> <td>0</td> <td>0</td> <td>0</td> <td>0</td> </tr> <tr> <td>0</td> <td>0</td> <td>0</td> <td>0</td> <td>1</td> <td>1</td> </tr> <tr> <td>0</td> <td>0</td> <td>0</td> <td>1</td> <td>0</td> <td>2</td> </tr> <tr> <td></td> <td></td> <td>etc.</td> <td></td> <td></td> <td></td> </tr> <tr> <td>1</td> <td>1</td> <td>1</td> <td>1</td> <td>1</td> <td>31</td> </tr> </tbody> </table> <p>CCS (CSIG=1 of register address Y03) and CST (TS16E=1 of register address Y06) must be selected for these operations to be valid.</p>	Bit Settings					Selected CST Timeslot	16C4	16C3	16C2	16C1	16C0		0	0	0	0	0	0	0	0	0	0	1	1	0	0	0	1	0	2			etc.				1	1	1	1	1	31
Bit Settings					Selected CST Timeslot																																							
16C4	16C3	16C2	16C1	16C0																																								
0	0	0	0	0	0																																							
0	0	0	0	1	1																																							
0	0	0	1	0	2																																							
		etc.																																										
1	1	1	1	1	31																																							
4 3 2 1 0	15C4 15C3 15C2 15C1 15C0 (01111)	<p>Timeslot 15 CST Map Bits. The selection of these bits results in a mapping of the transmit PCM30 timeslot 15, from a specific CSTi timeslot; and similarly, maps receive PCM30 timeslot 15, to a specific CSTo timeslot. PCM30 timeslot 15 data is mapped to/from CST channel n (n=0 to 31), where n is the BCD equivalent of 15C4 to 15C0 with 15C4 being the most significant bit.</p> <table border="1"> <thead> <tr> <th colspan="5">Bit Settings</th> <th>Selected CST Timeslot</th> </tr> <tr> <th>15C4</th> <th>15C3</th> <th>15C2</th> <th>15C1</th> <th>15C0</th> <th></th> </tr> </thead> <tbody> <tr> <td>0</td> <td>0</td> <td>0</td> <td>0</td> <td>0</td> <td>0</td> </tr> <tr> <td>0</td> <td>0</td> <td>0</td> <td>0</td> <td>1</td> <td>1</td> </tr> <tr> <td>0</td> <td>0</td> <td>0</td> <td>1</td> <td>0</td> <td>2</td> </tr> <tr> <td></td> <td></td> <td>etc.</td> <td></td> <td></td> <td></td> </tr> <tr> <td>1</td> <td>1</td> <td>1</td> <td>1</td> <td>1</td> <td>31</td> </tr> </tbody> </table> <p>CCS (CSIG=1 of register address Y03) and CST (TS15E=1 of register address Y06) must be selected for these operations to be valid.</p>	Bit Settings					Selected CST Timeslot	15C4	15C3	15C2	15C1	15C0		0	0	0	0	0	0	0	0	0	0	1	1	0	0	0	1	0	2			etc.				1	1	1	1	1	31
Bit Settings					Selected CST Timeslot																																							
15C4	15C3	15C2	15C1	15C0																																								
0	0	0	0	0	0																																							
0	0	0	0	1	1																																							
0	0	0	1	0	2																																							
		etc.																																										
1	1	1	1	1	31																																							

Table 154 - CCS to ST-BUS CSTi and CSTo Map Control Register (R/W Address Y07) (E1)

Bit	Name	Functional Description
15	#	not used.
14 13	Sa4SS (00)	<p>Sa4 Source Select. These 2 bits determine the source of the transmit Sa4 bits in timeslot 0 of NFAS frames.</p> <p>Select Bits: Sa4 Source</p> <ul style="list-style-type: none"> 00 Transmit National Data Register (YB0) 01 TxDL pin (received Sa4 bits are sent to the RxDL pin) 10 DSTi pin (ST-BUS Channel 0, Bit 4 in NFAS frames) 11 HDLC (Transmit and Receive Sa4 bits) <p>Note the received Sa4 bits are always available in the RX National Data Bit Buffer (YC0) and timeslot 0 on the DSTo pin.</p>
14 13	Sa5SS (00)	<p>Sa5 Source Select. These 2 bits determine the source of the transmit Sa5 bits in timeslot 0 of NFAS frames.</p> <p>Select Bits: Sa5 Source</p> <ul style="list-style-type: none"> 00 Transmit National Data Register (YB1) 01 TxDL pin (received Sa5 bits are sent to the RxDL pin) 10 DSTi pin (ST-BUS Channel 0, Bit 3 in NFAS frames) 11 HDLC (Transmit and Receive Sa5 bits) <p>Note the received Sa5 bits are always available in the RX National Data Bit Buffer (YC1) and timeslot 0 on the DSTo pin.</p>
10 9	Sa6SS (00)	<p>Sa6 Source Select. These 2 bits determine the source of the transmit Sa6 bits in timeslot 0 of NFAS frames.</p> <p>Select Bits: Sa6 Source</p> <ul style="list-style-type: none"> 00 Transmit National Data Register (YB2) 01 TxDL pin (received Sa6 bits are sent to the RxDL pin) 10 DSTi pin (ST-BUS Channel 0, bit 2 in NFAS frames) 11 HDLC (Transmit and Receive Sa6 bits) <p>Note the received Sa6 bits are always available in the RX National Data Bit Buffer (YC2) and timeslot 0 on the DSTo pin.</p>
8 7	Sa7SS (00)	<p>Sa7 Source Select. These 2 bits determine the source of the transmit Sa7 bits in timeslot 0 of NFAS frames.</p> <p>Select Bits: Sa7 Source</p> <ul style="list-style-type: none"> 00 Transmit National Data Register (YB3) 01 TxDL pin (received Sa7 bits are sent to the RxDL pin) 10 DSTi pin (ST-BUS Channel 0, Bit 1 in NFAS frames) 11 HDLC (Transmit and Receive Sa7 bits) <p>Note the received Sa7 bits are always available in the RX National Data Bit Buffer (YC3) and timeslot 0 on the DSTo pin.</p>
6 5	Sa8SS (00)	<p>Sa8 Source Select. These 2 bits determine the source of the transmit Sa8 bits in timeslot 0 of NFAS frames.</p> <p>Select Bits: Sa8 Source</p> <ul style="list-style-type: none"> 00 Transmit National Data Register (YB4) 01 TxDL pin (received Sa8 bits are sent to the RxDL pin) 10 DSTi pin (ST-BUS Channel 0, Bit 1 in NFAS frames) 11 HDLC (Transmit and Receive Sa8 bits) <p>Note the received Sa8 bits are always available to the RX National Data Bit Buffer (YC4) and timeslot 0 on the DSto pin.</p>
4-2	#	not used.

Table 155 - DataLink Control Register (R/W Address Y08) (E1)

Bit	Name	Functional Description
1	E4CK (0)	Extracted 4 Data Link Clock. If one, the RxDLC pin outputs an ST-BUS type 4.096MHz clock signal derived from a doubled 2.048MHz clock signal at the EXCLi pin. This clock is synchronous with the receive data before it passes through the elastic buffer at the RxDL pin, or at the DSTo pin if control bit \overline{ELAS} (register address Y03) is disabled. See Figure 32. If zero, the RxDLC pin operates as a receive data link clock or enable signal as programmed by control bit DLCK (register address Y08).
0	DLCK (0)	Data Link Clock. If one, the TxDLC and RxDLC pins output a gapped clock. If zero, the TxDLC and RxDLC pins output an active low enable signal. The above only applies for the national bits enabled for DL pin operation (by the Sa4-8 bits of register address Y03). See Figures 30 to 34.

Table 155 - DataLink Control Register (R/W Address Y08) (E1)

Bit	Name	Functional Description
15-8	#	not used.
7-0	RXIDC 7-0 (0)	Receive Idle Code. This is the idle code that is sent on the DSTochannels if the per timeslot control bit MPDR is set(Y90-YAF). Note that bit 7 is sent out first.

Table 156 - Receive Idle Code Register(Y09) (E1)

Bit	Name	Functional Description
15-8	#	not used.
7-0	TXIDC 7-0 (0)	Transmit Idle Code. This is the idle code that is sent on the PCM30 channels if the per timeslot control bit MPDT is set(Y90-YAF)

Table 157 - Transmit Idle Code Register(Y0A) (E1)

16.2.4 Master Status Registers (Y10 - Y1A) Bit Functions

Tables 158 to 172 describe the bit functions of each of the Master Status Registers in the MT9072 in E1 mode. Each register is repeated for each of the 8 framers. Framer 0 is addressed with Y=0, Framer 1 with Y=1, Framer 2 with Y=2 and so on up to Framer 7 with Y=7 (where Y represents the 4 most significant address bits (MSB) A11-A8).

Bit	Name	Functional Description
15	#	not used.
14	RSLP	Receive Slip. This bit changes state when a receive controlled frame slip has occurred.
13	RSLPD	Receive Slip Direction. If one, indicates that the last received frame slip (RSLP toggled of register Y10) resulted in a repeated frame. This would occur if the system clock (CKi/2) was faster than the network clock (EXCLi). If zero, indicates that the last received frame slip (RSLP) resulted in a lost frame. This would occur if the system clock (CKi/2) was slower than the network clock (EXCLi). Updated on an RSLP occurrence basis.
12	BSYNC	Receive Basic Frame Alignment. If zero, indicates the received PCM30 link basic frame alignment pattern (x0011011 in timeslot 0 of alternate frames) is acquired; if one, the basic frame alignment pattern is lost or not acquired.
11	MSYNC	Receive Multiframe Alignment. If zero, indicates the received PCM30 link signaling multiframe alignment signal (0000xxxx in timeslot 16 of every 16th frame) is acquired; if one, the signaling multiframe alignment signal is lost or not acquired.
10	CSYNC	Receive CRC-4 Synchronization. If zero, indicates the received PCM30 link CRC-4 multiframe alignment pattern (001011xx in timeslot 0, in bit position 1 of 16 alternate frames) is acquired; if one, the CRC-4 multiframe alignment pattern is lost or not acquired.
9	RED	RED Alarm. If one, indicates that basic frame alignment ($\overline{\text{BSYNC}}$ of register address Y10) has been lost for at least 100 msec. This bit is cleared (zero) when basic frame alignment is acquired.
8	CEFS	Consecutively Errored Frame Alignment Signal. If one, the last two frame alignment signals (FAS=0011011) were received in error. If zero, at least one of the last two frame alignment signals were received without error. A non-errored FAS would result in the RFA status bits (register address Y13) set as follows, RFA2=0, RFA3=0, RFA4=1, RFA5=1, RFA6=0, RFA7=1, RFA8=1
7	#	not used.
6	RCRC0	Remote CRC-4 and RAI T10. If one, the received A bits were one and the received E bits were zero (RCRCR register address Y10) continuously for more than 10ms. See I.431 section 3.4.1.2 on RAI and continuous CRC error information.
5	RCRC1	Remote CRC-4 and RAI T450. If one, the received A bits were one and the received E bits were zero (RCRCR register address Y10) continuously for more than 10ms but less than 450ms. See I.431 section 3.4.1.2 on RAI and continuous CRC error information.
4	RFAIL	Remote CRC-4 Multiframe Generator/Detector Failure. If one, each of the previous five seconds have an E-bit (E1 + E2) of error count of greater than 989 (E-bit counter 3DD hex or 11 1101 1101 address Y17), and for this same period the receive RAI bit (register address Y12 and Y13) was zero (no remote alarm), and for the same period the $\overline{\text{BSYNC}}$ bit (register address Y10) was equal to zero (basic frame alignment has been maintained). If zero, indicates normal operation.
3	REB1	Receive E1 Bit Status. Indicates the status of the bit (E1) received on the PCM30 link in bit position 1 of timeslot 0 in non-frame alignment signal (NFAS) frame 13. If zero, the remote end calculated a CRC-4 error in its received sub-multiframe one. If one, no error was calculated.

Table 158 - Synchronization & CRC-4 Remote Status (R Address Y10) (E1)

Bit	Name	Functional Description
2	REB2	Receive E2 Bit Status. Indicates the status of the bit (E2) received on the PCM30 link in bit position 1 of timeslot 0 in non-frame alignment signal (NFAS) frame 15. If zero, the remote end calculated a CRC-4 error in its received sub-multiframe two. If one, no error was calculated.
1	RCRCR	Remote CRC-4 and RAI. If one, the RAI (A) status bit (register address Y12 and Y13) is one, and the REB1 (E1) and REB2 (E2) status bits (register address Y10) are zero. If zero, the above requirement is not met.
0	CRCIW	CRC-4 Interworking. If one, indicates the CRC-4 interworking status is CRC-4 to CRC-4 (local to remote). The transmit PCM30 link is framed to CRC-4 with E1 and E2 bits sent, and the receive PCM30 link is treated as CRC-4 with E1 and E2 bits received. If zero, indicates the CRC-4 interworking status is CRC-4 to non-CRC (local to remote). In this case, the transmit PCM30 link is framed to CRC-4 but the E1 and E2 bits are not sent, and the receive PCM30 link is not treated as a CRC-4 multiframe but only as a basic frame and signaling multiframe frame only.

Table 158 - Synchronization & CRC-4 Remote Status (R Address Y10) (E1)

Bit	Name	Functional Description
15-13	###	not used.
13	ONESEC	One Second Timer Status. This bit toggles from low to high once every one second, and is synchronous with the applied 125us frame pulse at pin FPi.
12	TWOSEC	Two Second Timer Status. This bit toggles from low to high once every two seconds, and is synchronous with the applied 125us frame pulse at pin FPi.
11	T1	Timer 1. If one, indicates that a receive PCM30 link with non-normal operational CRC-4 frames (CSYNC=1 of register address Y10) has persisted for at least 100ms. This bit is zero when Timer 2 (T2 of register address Y11) is one. Refer to I.431 Section 5.9.2.2.3.
10	T2	Timer 2. If one, indicates that a receive PCM30 link with normal operational CRC-4 frames (CSYNC=0 of register address Y11) has persisted for at least 10ms. This bit is cleared (zero) when non-normal operational frames (CSYNC=1) occur. Refer to I.431 Section 5.9.2.2.3.
9	T400	400ms Timer Status. This is the 400ms CRC-4 multiframe alignment timer. This bit initially changes state from zero to one synchronously with the T8 (register address Y11) bit after the T8 bit has consecutively toggled 50 times (400ms). While this condition persists (T8=0101 etc.), the T400 bit continues to change state every 400ms. The T400 bit is cleared (zero) with the T8 bit when CRC-4 multiframe synchronization is acquired (CSYNC =0).
8	T8	8ms Timer Status. This is the 8ms CRC-4 multiframe alignment timer. This bit initially changes state from zero to one synchronously with the CRCRF (register address Y11) bit when the received PCM30 link CRC-4 multiframe synchronization (CSYNC of register address Y10) could not be found within the time out period of 8 ms after detecting basic frame synchronization (BSYNC=0 of register address Y10). While this condition persists (CRCRF=1), the T8 bit continues to change state every 8ms. The T8 bit is cleared (zero) with the CRCRF bit when CRC-4 multiframe synchronization is acquired (CSYNC =0).
7-5	###	not used.
4	CALN	CRC-4 Alignment 2ms Timer. When CRC-4 multiframe alignment has not been achieved (CSYNC=1 of register address Y10), this bit asynchronously changes state every 2 ms. When CRC-4 multiframe alignment has been achieved (CSYNC =0), this bit still changes state every 2 ms, but is synchronous with the receive CRC-4 multiframe signal.
3	CRCRF	CRC-4 Reframe. If one, indicates the received PCM30 link CRC-4 multiframe synchronization (CSYNC of register address Y10) could not be found within the time out period of 8ms after detecting basic frame synchronization (BSYNC of register address Y10). This bit is cleared (zero) when CRC-4 multiframe synchronization is acquired (CSYNC =0).
2	CRCS1	Receive CRC-4 Error Status One. If one, the CRC-4 evaluation of the last received PCM30 link submultiframe 1 resulted in an error (the calculated C1,C2,C3,C4 CRC-4 remainder bits did not match the received CRC-4 remainder C1,C2,C3,C4 bits). If zero, the last submultiframe 1 was error free. Updated on a submultiframe 1 basis.
1	CRCS2	Receive CRC-4 Error Status Two. If one, the CRC-4 evaluation of the last received PCM30 link submultiframe 2 resulted in an error (the calculated C1,C2,C3,C4 CRC-4 remainder bits did not match the received CRC-4 remainder C1,C2,C3,C4 bits). If zero, the last submultiframe 2 was error free. Updated on a submultiframe 2 basis.
0	(#)	not used.

Table 159 - CRC-4 Timers & CRC-4 Local Status (R Address Y11) (E1)

Bit	Name	Functional Description
15-14	##	not used.
13	KLVE	Keep Alive. If one, indicates that the AIS status bit (register address Y12) has been one for at least 100ms. This bit is zero when AIS is zero. Refer to I.431.
12	LOSS	Loss of Signal Status Indication. If one, indicates the presence of a loss of signal condition on the received PCM30 link. A loss of signal condition occurs when 192 or 32(selectable by L32Z in Y01) consecutive bit periods are zero. A loss of signal condition terminates when an average ones density of at least 12.5% has been received over a period of 255 contiguous pulse positions starting with a pulse. If zero, indicates normal operation.
11	AIS16	Alarm Indication Signal 16 Status. If one, indicates an all ones signal (1111 1111) is being received in timeslot16 of the received PCM30 link for the current frame. Updated on a basic frame basis. If zero, normal operation.
10	AIS	Alarm Indication Status Signal. If one, indicates that an Alarm Indication Signal (AIS) is detected on the received PCM30 link. The criteria (i.e. less than three zeros in a two frame period) for AIS detection is determined by the control bit ASEL (register address Y00). If the AIS bit is zero, indicates that an AIS signal not being received.
9	RAI	Remote Alarm Indication Status. Indicates the status of the bit (A-bit) received on the PCM30 link in bit position 3 of timeslot 0 of the non-frame alignment signal (NFAS) frames. If one, there is currently a remote alarm condition. Updated on a NFAS frame basis. This bit is identical to the RAI bit of register address Y13 and is duplicated here for convenience.
8	AUXP	Auxiliary Pattern. If one, an auxiliary pattern (101010) of at least 512 bits is being received on the PCM30 link. If zero, an auxiliary pattern is not being received. This pattern will be decoded in the presents of a bit error rate of as much as 10^{-3} .
7 6 5 4	RMA1 RMA2 RMA3 RMA4	Receive Multiframe Alignment Bits One to Four. Indicates the status of the bits received on the PCM30 link in bit positions one to four of timeslot 16 of frame 0 of the multiframe alignment signal (MAS). These bits should be 0000 for proper signaling multiframe alignment. Updated on a MAS frame basis.
3	X1	Receive Spare Bit X1. Indicates the status of the bit received on the PCM30 link in bit position five of timeslot 16 of frame 0 of the multiframe alignment signal (MAS). Updated on a MAS frame basis.
2	Y	Receive Y-bit. Indicates the status of the bit (Y-bit) received on the PCM30 link in bit position six of timeslot 16 of frame 0 of the multiframe alignment signal (MAS). Updated on a MAS frame basis. If one, typically indicates a loss of multiframe alignment at the remote end. If zero, typically indicates acquired multiframe alignment at the remote end.
1 0	X2 X3	Receive Spare Bits X2 and X3. Indicates the status of the bits received on the PCM30 link in bit positions seven and eight of timeslot 16 of frame 0 of the multiframe alignment signal (MAS). Updated on a MAS frame basis.

Table 160 - Alarms & Multiframe Signaling (MAS) Status (R Address Y12) (E1)

Bit	Name	Functional Description
15	RIU1	Receive International Use 1. Indicates the status of the bit received on the PCM30 link in bit position one of timeslot 0 of the non-frame alignment signal (NFAS) frames. This bit is the CRC-4 multiframe alignment bit (001011) of the NFAS frames (1,3,5,7,9,11) when CRC-4 multiframing is used. Or, this bit is used for international use.
14	RNFA	Receive Non-Frame Alignment Bit. Indicates the status of the bit received on the PCM30 link in bit position two of timeslot 0 of the non-frame alignment signal (NFAS) frames. This bit should be one and identifies the frame as an NFAS frame (the FAS frame should have a zero in bit position two of timeslot 0).
13	RAI	Remote Alarm Indication Status. Indicates the status of the bit (A-bit) received on the PCM30 link in bit position 3 of timeslot 0 of the non-frame alignment signal (NFAS) frames. If one, there is currently a remote alarm condition. Updated on a NFAS frame basis. This bit is identical to the RAI bit of register address Y12 and is duplicated here for convenience.
12 11 10 9 8	RNU4 RNU5 RNU6 RNU7 RNU8	Receive National Use Four to Eight. Indicates the value of the Sa bits received on the PCM30 link in bit positions four to eight of timeslot 0 of the non-frame alignment signal (NFAS) frames. Sa4 corresponds to RNU4, Sa5 to RNU5 and so on up to Sa8 to RNU8. Updated on a NFAS frame basis.
7	RIU0	Receive International Use Zero. Indicates the status of the bit received on the PCM30 link in bit position one of timeslot 0 of the frame alignment signal (FAS) frames. This bit is the CRC-4 remainder bit (C1,C2,C3 or C4) of the FAS frames when CRC-4 multiframing is used. Or, this bit is used for international use.
6 5 4 3 2 1 0	RFA2 RFA3 RFA4 RFA5 RFA6 RFA7 RFA8	Receive Frame Alignment Signal (FAS) Bits 2 to 8. Indicates the value of the bits received on the PCM30 link in bit positions two to eight of timeslot 0 of the frame alignment signal (FAS) frames. These bits form the FAS and should have the value of 0011011.

Table 161 - Non-Frame Alignment (NFAS) Signal and Frame Alignment Signal (FAS) Status (R Address Y13) (E1)

Bit	Name	Functional Description
15-12	####	not used.
		Phase Indicator. These 12 bits are an indication of the delay through the receive slip buffer and the imminence of a receive frame slip. The read address is this register's value plus 16 bits and is updated when the write address is zero. The slip buffer contains 512 bits on 64 channels (0 thru 63). The accuracy of this indicator is approximately 1/16 of a bit.
11	PI11	This bit indicates a 1 frame (32 timeslot or 256 bit) phase offset.
10	PI10	This bit indicates a 16 timeslot (128 bit) phase offset.
9	PI9	This bit indicates a 4 timeslot (64 bit) phase offset.
8	PI8	This bit indicates a 3 timeslot (32 bit) phase offset.
7	PI7	This bit indicates a 2 timeslot (16 bit) phase offset.
6	PI6	This bit indicates a 1 timeslot (8 bit) phase offset.
5	PI5	This bit indicates a 4 bit phase offset.
4	PI4	This bit indicates a 2 bit phase offset.
3	PI3	This bit indicates a 1 bit phase offset.
2	PI2	This bit indicates a 1/2 bit phase offset.
1	PI1	This bit indicates a 1/4 bit phase offset.
0	PI0	This bit indicates a 1/8 bit phase offset.

Table 162 - Phase Indicator Status (R Address Y14) (E1)

Bit	Name	Functional Description
15	PEC7	Pseudo Random Bit Sequence (PRBS) Error Counter. These bits make up a counter which is incremented for each pseudo random bit sequence (PRBS) ($2^{15}-1$) error detected on any of the DSTo receive channels connected (ADSEQ=0 register address Y01, RRSTn=1 register address Y90 to YAF) to the PRBS error detector. This counter is cleared with an overflow, a RESET ($\overline{\text{RESET}}$ pin or RST bit), or may be set by writing the desired value to it. PEC0 is the least significant bit (LSB). The lower byte and upper byte of register cannot be written to independently.
14	PEC6	
13	PEC5	
12	PEC4	
11	PEC3	
10	PEC2	
9	PEC1	
8	PEC0	
7	PCC7	Pseudo Random Bit Sequence (PRBS) CRC-4 Counter. These bits make up a counter which is incremented for each received CRC-4 multiframe. This counter is cleared with an overflow, a RESET ($\overline{\text{RESET}}$ pin or RST bit), or may be set by writing the desired value to it. PCC0 is the least significant bit (LSB). The lower byte and upper byte of register cannot be written to independently.
6	PCC6	
5	PCC5	
4	PCC4	
3	PCC3	
2	PCC2	
1	PCC1	
0	PCC0	

Table 163 - PRBS Error Counter & PRBS CRC-4 Counter (R/W Address Y15) (E1)

Bit	Name	Functional Description
15	SLC15	Loss of Basic Frame Synchronization Counter. These bits make up a counter which is incremented for each 125us period in which basic frame synchronization ($\overline{\text{BSYNC}}=1$ status register address Y10) is lost. This counter is cleared by a basic frame synchronization to a loss of basic frame synchronization state transition ($\overline{\text{BSYNC}}=0$ to 1), or with an overflow, a RESET ($\overline{\text{RESET}}$ pin or RST bit), or it may be set by writing the desired value to it. SLC0 is the least significant bit (LSB).
14	SLC14	
13	SLC13	
12	SLC12	
11	SLC11	
10	SLC10	
9	SLC9	
8	SLC8	
7	SLC7	
6	SLC6	
5	SLC5	
4	SLC4	
3	SLC3	
2	SLC2	
1	SLC1	
0	SLC0	

Table 164 - Loss of Basic Frame Synchronization Counter with Auto Clear (R/W Address Y16) (E1)

Bit	Name	Functional Description
15	EEC15	E-bit Error Counter. These bits make up a counter which is incremented for each received PCM30 CRC-4 submultiframe E-bit error. This counter is cleared with an overflow, a RESET ($\overline{\text{RESET}}$ pin or RST bit), or may be set by writing the desired value to it. EEC0 is the least significant bit (LSB).
14	EEC14	
13	EEC13	
12	EEC12	
11	EEC11	
10	EEC10	
9	EEC9	
8	EEC8	
7	EEC7	
6	EEC6	
5	EEC5	
4	EEC4	
3	EEC3	
2	EEC2	
1	EEC1	
0	EEC0	

Table 165 - E-bit Error Counter (R/W Address Y17) (E1)

Bit	Name	Functional Description
15	VEC15	Bipolar Violation Error Counter. These bits make up a counter which is incremented for each received bipolar violation error. This counter is cleared with an overflow, a RESET ($\overline{\text{RESET}}$ pin or RST bit), or may be set by writing the desired value to it. VEC0 is the least significant bit (LSB).
14	VEC14	
13	VEC13	
12	VEC12	
11	VEC11	
10	VEC10	
9	VEC9	
8	VEC8	
7	VEC7	
6	VEC6	
5	VEC5	
4	VEC4	
3	VEC3	
2	VEC2	
1	VEC1	
0	VEC0	

Table 166 - Bipolar Violation (BPV) Error Counter (R/W Address Y18) (E1)

Bit	Name	Functional Description
15	CEC15	CRC-4 Error Counter. These bits make up a counter which is incremented for each calculated CRC-4 submultiframe error (see CRCS1 and CRCS2 bits of register address Y11). This counter is cleared with an overflow, a RESET ($\overline{\text{RESET}}$ pin or RST bit), or may be set by writing the desired value to it. CEC0 is the least significant bit (LSB).
14	CEC14	
13	CEC13	
12	CEC12	
11	CEC11	
10	CEC10	
9	CEC9	
8	CEC8	
7	CEC7	
6	CEC6	
5	CEC5	
4	CEC4	
3	CEC3	
2	CEC	
1	CEC1	
0	CEC0	

Table 167 - CRC-4 Error Counter (R/W Address Y19) (E1)

Bit	Name	Functional Description
15 14 13 12 11 10 9 8	BEC7 BEC6 BEC5 BEC4 BEC3 BEC2 BEC1 BEC0	Frame Alignment Signal (FAS) Bit Error Counter. These bits make up a counter which is incremented for each individual error in the received PCM30 link basic frame alignment signal (FAS) pattern (x0011011 in timeslot 0 of alternate frames). This counter is cleared with an overflow, a RESET ($\overline{\text{RESET}}$ pin or RST bit), or it may be set by writing the desired value to it. BEC0 is the least significant bit (LSB). The lower byte and upper byte of register cannot be written to independently.
7 6 5 4 3 2 1 0	FEC7 FEC6 FEC5 FEC4 FEC3 FEC2 FEC1 FEC0	Frame Alignment Signal (FAS) Error Counter. These bits make up a counter which is incremented for each combined (one or more) error in the received PCM30 link basic frame alignment signal (FAS) pattern (x0011011 in timeslot 0 of alternate frames). This counter is cleared with an overflow, a RESET ($\overline{\text{RESET}}$ pin or RST bit), or it may be set by writing the desired value to it. FEC0 is the least significant bit (LSB). The lower byte and upper byte of register cannot be written to independently.

Table 168 - Frame Alignment Signal (FAS) Bit Error Counter & FAS Error Counter (R/W Address Y1A) (E1)

Bit	Name	Functional Description
15-12	####	not used.
11	RXclk	This bit represents the receiver clock generated after the RXEN control bit, but before zero deletion is considered.
10	TXclk	This bit represents the transmit clock generated after the TXEN control bit, but before zero insertion is considered.
9	Vcrc	This is the CRC recognition status bit for the receiver. Data is clocked into the register and then this bit is monitored to see if comparison was successful (bit will be high).
8	Vaddr	This is the address recognition status bit for the receiver. Data is clocked into the Address Recognition Register and then this bit is monitored to see if comparison was successful (bit will be high).
7 - 0	TBP7-0	Transmit Byte Counter Position. These 7 bits provide the position of the Transmit HDLC Byte Counter register (YF6). The counter is decremented as a byte of data is sent through the Transmit FIFO. When this register reaches the count of one, the next write to the Tx FIFO will be tagged as an end of packet byte. The counter decrements at the end of the write to the Tx FIFO. If the Cycle bit of YF2 is set high, the counter will cycle through the programmed value continuously.

Table 169 - Transmit Byte Counter Position and HDLC Test Status(Y1C) (E1)

Bit	Name	Functional Description
6	IDC	Idle Channel State. Is set to a 1 when an idle Channel state (15 or more ones) has been detected at the receiver. This is an asynchronous event. On power reset, this may be 1 if the clock (RXC) was not operating. Status becomes valid after the first 15 bits or the first zero is received.
5-4	RQ9-8	RQ9-8 Byte Status bits from RX FIFO. These bits determine the status of the byte to be read from RX FIFO as follows: 00 Packet Byte 01 First Byte 10 Last byte of good packet 11 Last byte of bad packet
3-2	TXSTAT1-0	Transmit FIFO Status: 00 Transmit FIFO is full. 01 The number of bytes in the transmit FIFO has reached or exceeded 16 bytes 10 Transmit FIFO is empty 11 The number of bytes in the TX FIFO is less than the 16 byte threshold.
1-0	RXSTAT1-0	Receive FIFO Status: 00 Receive FIFO is full. 01 The number of bytes in the Receive FIFO has reached or exceeded 16 bytes 10 Receive FIFO is empty 11 The number of bytes in the Receive FIFO is less than the 16 byte threshold.

Table 170 - HDLC Status Register(Y1D) (E1)

Bit	Name	Functional Description
15-0	RCRC15-0	Received CRC. The CRC received from the transmitter. The LSB of the FCS sequence is MSB in this register. This register is updated at the end of each received packet and therefore should be read when end of packet is detected.

Table 171 - HDLC Receive CRC(Y1E) (E1)

Bit	Name	Functional Description
7 - 0	RXFIFO7-0	Receive FIFO. This is the received data byte read from the RX FIFO. The status bits of this byte can be read from the status register. The FIFO status is not changed immediately when a write or read occurs. It is updated after the data has settled and the transfer to the last available position has finished.

Table 172 - HDLC Receive FIFO(Y1F) (E1)

16.2.5 Latched Status Registers (Y2X) Bit Functions

Tables 173 to 181 describe the bit functions of each of the Latched Status Registers in the MT9072 in E1 mode. Each register is repeated for each of the 8 framers. Framer 0 is addressed with Y=0, Framer 1 with Y=1, Framer 2 with Y=2 and so on up to Framer 7 with Y=7 (where Y represents the 4 most significant address bits (MSB) A11-A8). All latched status registers will be reset in the inactive state upon reset.

Bit	Name	Functional Description
15-9	#####	not used.
8	GAL	Go Ahead received Latch. Indicates a go-ahead pattern (01111111) was detected by the HDLC receiver. This bit is reset after a read.
7	EOPDL	End of Packet Data Latch. This bit is set when an end of packet (EOP) byte was written into the RX FIFO by the HDLC receiver. This can be in the form of a flag, an abort sequence or as an invalid packet. This bit is reset after a read.
6	TEOPL	Transmit End of Packet Latch. This bit is set when the transmitter has finished sending the closing flag of a packet or after a packet has been aborted. This bit is reset after read.
5	EOPRL	End of Packet received latch. This bit is set when the byte about to be read from the RX FIFO is the last byte of the packet. It is also set if the Rx FIFO is read and there is no data in it. This bit is reset after a read.
4	TXFL	Transmit Fifo Low Latch. This bit is set when the Tx FIFO is emptied below the selected low threshold level. This bit is reset after a read.
3	FAL	Framer Abort Latch. This bit (FA) is set when a frame abort is received during packet reception. It must be received after a minimum number of bits have been received (26) otherwise it is ignored.
2	TXunder	Txunder Latch. This bit is set for a TX FIFO underrun indication. If high it Indicates that a read by the transmitter was attempted on an empty Tx FIFO. This bit is reset after a read.
1	RxffL	Receive Fifo Full Latch. This bit is set when the Rx FIFO is filled above the selected full threshold level. This bit is reset after a read.
0	RxOvfL	Receive Overflow Latch. Indicates that the 32 byte RX FIFO overflowed (i.e. an attempt to write to a 32byte full RX FIFO). The HDLC will always disable the receiver once the receive overflow has been detected. The receiver will be re-enabled upon detection of the next flag, but will overflow again unless the RX FIFO is read. This bit is reset after a read.

Table 173 - HDLC Status Latch(Y23) (E1)

Bit	Name	Functional Description
15	#	not used.
14	RCRCRL	Remote CRC-4 and RAI Latch. When the RCRCR status bit (register address Y10) toggles from zero to one, this status bit is latched to one. This bit is cleared when either this register, or the interrupt status register (register address Y34) is read.
13	RSLPL	Receive Slip Latch. When the RSLP status bit (register address Y13) toggles from zero to one, or from one to zero, this status bit is latched to one. This bit is cleared when either this register, or the interrupt status register (register address Y34) is read.
12	YL	Receive Y-bit Latch. When the Y status bit (register address Y12) toggles from zero to one, or from one to zero, this status bit is latched to one. This bit is cleared when either this register, or the interrupt status register (register address Y34) is read.

Table 174 - Sync, CRC-4 Remote, Alarms, MAS and Phase Latched Status Register (Address Y24) (E1)

Bit	Name	Functional Description
11	AUXPL	Auxiliary Pattern Latch. When the AUXP status bit (register address Y12) toggles from zero to one, this status bit is latched to one. This bit is cleared when either this register, or the interrupt status register (register address Y34) is read.
10	RAIL	Remote Alarm Indication Status Latch. When the RAI (A) status bit (register address Y12 and Y13) toggles from zero to one, or from one to zero, this status bit is latched to one. This bit is cleared when either this register, or the interrupt status register (register address Y34) is read.
9	AISL	Alarm Indication Status Signal Latch. When the AIS status bit (register address Y12) toggles from zero to one, or from one to zero, this status bit is latched to one. This bit is cleared when either this register, or the interrupt status register (register address Y34) is read.
8	$\overline{\text{AIS16L}}$	Alarm Indication Signal 16 Status Latch. When the AIS16 status bit (register address Y12) toggles from zero to one, or from one to zero, this status bit is latched to one. This bit is cleared when either this register, or the interrupt status register (register address Y34) is read.
7	LOSSL	Loss of Signal Status Indication Latch. When the LOSS status bit (register address Y12) toggles from zero to one, or from one to zero, this status bit is latched to one. This bit is cleared when either this register, or the interrupt status register (register address Y34) is read.
6	RCRC0L	Remote CRC-4 and RAI T10 Latch. When the RCRC0 status bit (register address Y10) toggles from zero to one, this status bit is latched to one. This bit is cleared when either this register, or the interrupt status register (register address Y34) is read.
5	RCRC1L	Remote CRC-4 and RAI T450 Latch. When the RCRC1 status bit (register address Y10) toggles from zero to one, this status bit is latched to one. This bit is cleared when either this register, or the interrupt status register (register address Y34) is read.
4	CEFSL	Consecutively Errored Frame Alignment Signal Latch. When the CEFS status bit (register address Y10) toggles from zero to one, this status bit is latched to one. This bit is cleared when either this register, or the interrupt status register (register address Y34) is read.
3	RFAILL	Remote CRC-4 Multiframe Generator/Detector Failure Latch. When the status bit (register address Y10) toggles from zero to one, this status bit is latched to one. This bit is cleared when either this register, or the interrupt status register (register address Y34) is read.
2	CSYNCL	Receive CRC-4 Synchronization Latch. When the $\overline{\text{CSYNC}}$ status bit (register address Y10) toggles from zero to one, or from one to zero, this status bit is latched to one. This bit is cleared when either this register, or the interrupt status register (register address Y34) is read.
1	MSYNCL	Receive Multiframe Alignment Latch. When the $\overline{\text{MSYNC}}$ status bit (register address Y10) toggles from zero to one, or from one to zero, this status bit is latched to one. This bit is cleared when either this register, or the interrupt status register (register address Y34) is read.
0	BSYNCL	Receive Basic Frame Alignment Latch. When the $\overline{\text{BSYNC}}$ status bit (register address Y10) toggles from zero to one, or from one to zero, this status bit is latched to one. This bit is cleared when either this register, or the interrupt status register (register address Y34) is read.

Table 174 - Sync, CRC-4 Remote, Alarms, MAS and Phase Latched Status Register (Address Y24) (E1)

Bit	Name	Functional Description
15	#	not used.
14	SLOL	Loss of Sync Counter Overflow Latch. When the Loss of Sync Counter (SLC15-0 register address Y16) overflows (3FF to 00), this status bit is latched to one. This bit is cleared when either this register, or the interrupt status register (register address Y35) is read.
13	FEOL	Frame Alignment Signal (FAS) Error Counter Overflow Latch. When the FAS Error Counter (FEC7-0 register address Y1A lower byte) overflows (FF to 00), this status bit is latched to one. This bit is cleared when either this register, or the interrupt status register (register address Y35) is read.
12	FEIL	Frame Alignment Signal (FAS) Error Counter Indication Latch. When the FAS Error Counter (FEC7-0 register address Y1A lower byte) is incremented by one, this status bit is latched to one. This bit is cleared when either this register or the interrupt status register (register address Y35) is read.
11	BEOL	Frame Alignment Signal (FAS) Bit Error Counter Overflow Latch. When the FAS Bit Error Counter (BEC7-0 register address Y1A upper byte) overflows (FF to 00), this status bit is latched to one. This bit is cleared when either this register, or the interrupt status register (register address Y35) is read.
10	BEIL	Frame Alignment Signal (FAS) Bit Error Counter Indication Latch. When the FAS Bit Error Counter (BEC7-0 register address Y1A upper byte) is incremented by one, this status bit is latched to one. This bit is cleared when either this register, or the interrupt status register (register address Y35) is read.
9	CEOL	CRC-4 Error Counter Overflow Latch. When the CRC-4 Error Counter (CEC15-0 register address Y19) overflows (3FF to 000), this status bit is latched to one. This bit is cleared when either this register, or the interrupt status register (register address Y35) is read.
8	CEIL	CRC-4 Error Counter Indication Latch. When the CRC-4 Error Counter (CEC15-0 register address Y19) is incremented by one, this status bit is latched to one. This bit is cleared when either this register, or the interrupt status register (register address Y35) is read.
7	VEOL	Bipolar Violation (BPV) Error Counter Overflow Latch. When the BPV Error Counter (VEC15-0 register address Y18) overflows (FFFF to 000), this status bit is latched to one. This bit is cleared when either this register, or the interrupt status register (register address Y35) is read.
6	VEIL	Bipolar Violation (BPV) Error Counter Indication Latch. When the BPV Error Counter (VEC15-0 register address Y18) is incremented by one, this status bit is latched to one. This bit is cleared when either this register, or the interrupt status register (register address Y35) is read.
5	EEOL	E-Bit Error Counter Overflow Latch. When the E-Bit Error Counter (EEC15-0 register address Y17) overflows (3FF to 000), this status bit is latched to one. This bit is cleared when either this register, or the interrupt status register (register address Y35) is read.
4	EEIL	E-Bit Error Counter Indication Latch. When the E-Bit Error Counter (EEC15-0 register address Y17) is incremented by one, this status bit is latched to one. This bit is cleared when either this register, or the interrupt status register (register address Y35) is read.
3	PCOL	PRBS CRC-4 Counter Overflow Latch. When the PRBS CRC-4 Counter (PCC7-0 register address Y15 lower byte) overflows (FF to 00), this status bit is latched to one. This bit is cleared when either this register, or the interrupt status register (register address Y35) is read.
2	#	not used.
1	PEOL	PRBS Error Counter Overflow Latch. When the PRBS Error Counter (PEC7-PEC0 register address Y15 upper byte) overflows (FF to 00), this status bit is latched to one. This bit is cleared when either this register, or the interrupt status register (register address Y35) is read.

Table 175 - Counter Indication and Counter Overflow Latched Status Register (Address Y25) (E1)

Bit	Name	Functional Description
0	PEIL	PRBS Error Counter Indication Latch. When the PRBS Error Counter (PEC7-PEC0 register address Y15 upper byte) is incremented by one, this status bit is latched to one. This bit is cleared when either this register, or the interrupt status register (register address Y35) is read.

Table 175 - Counter Indication and Counter Overflow Latched Status Register (Address Y25) (E1)

Bit	Name	Functional Description
15	#	not used.
14	Sa5VL	Sa5 Bit Value Latch. This is the latched value of the Sa5 National bit when the Sa6N8L bit toggles to one. The Sa5VL bit is cleared when either this register, or the corresponding interrupt status register (register address Y36) is read.
13 12 11 10	Sa6V3L Sa6V2L Sa6V1L Sa6V0L	Sa6 Nibble (bit 3 to 0) Value Latch. This is the latched value of the Sa6 National bits nibble (bits 3 to 0) when the Sa6N8L bit toggles to one. These bits are cleared when either this register, or the corresponding interrupt status register (register address Y36) is read.
9	Sa6N8L	Sa6 Nibble Eight Consecutive Times Status Latch. When eight consecutive identical receive Sa6 National bit nibble patterns are received (per sub-multiframe), this status bit is latched to one. This bit is set on a CRC-4 sub-multiframe basis. This bit is cleared when either this register, or the corresponding interrupt status register (register address Y36) is read.
8	Sa6NL	Sa6 Nibble Change Status Latch. When a received Sa6 National bit nibble (per sub-multiframe) changes value, this status bit is latched to one. This bit is set on a CRC-4 sub-multiframe basis. This bit is cleared when either this register, or the corresponding interrupt status register (register address Y36) is read.
7	SaNL	Sa Nibble Change Status Latch. When any receive National (i.e. Sa5,Sa6,Sa7 or Sa8) bits nibbles changes value, this status bit is latched to one. This bit is set on a CRC-4 sub-multiframe basis. This bit is cleared when either this register, or the corresponding interrupt status register (register address Y36) is read.
6	Sa5TL	Sa5 Bit Change Status Latch. When a received Sa5 National bit changes value, this status bit is latched to one. This bit is set on a CRC-4 NFAS frame basis. This bit is cleared when either this register, or the corresponding interrupt status register (register address Y36) is read.
5	SaTL	Sa Bit Change Status Latch. When any receive National (i.e. Sa5,Sa6,Sa7 or Sa8) bit changes value, this status bit is latched to one. This bit is set on a CRC-4 NFAS frame basis. This bit is cleared when either this register, or the corresponding interrupt status register (register address Y36) is read.
4	CASRL	Receive Channel Associated Signaling (CAS) Change Latch. When any of the receive CAS (i.e. ABCD) bits in the Receive CAS Data Registers (address Y70-Y8F) change state, this status bit is latched to one. This bit is set on a basic frame (FPi) basis. This bit is cleared when either this register, or the corresponding interrupt status register (register address Y34) is read.
3	CALNL	CRC-4 Alignment 2ms Timer Latch. When the CALN status bit (register address Y11) toggles from zero to one, this status bit is latched to one. This bit is set on a 2ms or CRC-4 multiframe frame basis. This bit is cleared when either this register, or the corresponding interrupt status register (register address Y36) is read.

Table 176 - CAS, National, CRC-4 Local and Timer Latched Status Register (Address Y26) (E1)

Bit	Name	Functional Description
2	T2L	Timer 2 Latch. When the CRC-4 T2 (10ms) status bit (register address Y11) toggles from zero to one, this status bit is latched to one. This bit is set on a basic frame (FPI) basis. This bit is cleared when either this register, or the corresponding interrupt status register (register address Y36) is read.
1	T1L	Timer 1 Latch. When the CRC-4 T1 (100ms) status bit (register address Y11) toggles from zero to one, this status bit is latched to one. This bit is set on a basic frame (FPI) basis. This bit is cleared when either this register, or the corresponding interrupt status register (register address Y36) is read.
0	ONESECL	One Second Timer Status Latch. When the ONESEC status bit (register address Y11) toggles from zero to one, this status bit is latched to one. This bit is set on a basic frame (FPI) basis. This bit is cleared when either this register, or the corresponding interrupt status register (register address Y36) is read.

Table 176 - CAS, National, CRC-4 Local and Timer Latched Status Register (Address Y26) (E1)

Bit	Name	Functional Description
15-4	#	not used.
3	RAIP	Remote Alarm Indication Status Persistent Latch. When the RAI (A) status bit (register address Y12 and Y13) toggles from zero to one, this status bit is latched to one. This bit is cleared when this register is read while the RAI status bit is zero.
2	AISP	Alarm Indication Status Signal Persistent. When the AIS status bit (register address Y12) toggles from zero to one, this status bit is latched to one. This bit is cleared when this register is read while the AIS status bit is zero.
1	LOSSP	Loss of Signal Status Indication Persistent Latch. When the LOSS status bit (register address Y12) toggles from zero to one, this status bit is latched to one. This bit is cleared when this register is read while the LOSS status bit is zero.
0	BSYNCP	Receive Basic Frame Alignment Persistent Latch. When the $\overline{\text{BSYNC}}$ status bit (register address Y10) toggles from zero to one, this status bit is latched to one. This bit is cleared when this register is read while the $\overline{\text{BSYNC}}$ status bit is zero.

Table 177 - Performance Persistent Latched Status Register (Address Y27) (E1)

Bit	Name	Functional Description
15	EEL15	E-bit Error Count Latch. These bits make up a latch which samples the current value of the E-Bit Error Counter (address Y17) on the rising edge of the internal one second timer (ONESEC register address Y11). This latch is cleared with a RESET ($\overline{\text{RESET}}$ pin or RST bit). EEL0 is the least significant bit (LSB).
14	EEL14	
13	EEL13	
12	EEL12	
11	EEL11	
10	EEL10	
9	EEL9	
8	EEL8	
7	EEL7	
6	EEL6	
5	EEL5	
4	EEL4	
3	EEL3	
2	EEL2	
1	EEL1	
0	EEL0	

Table 178 - E-Bit Error Count Latch (R Address Y28) (E1)

Bit	Name	Functional Description
15	VEL15	Bipolar Violation (BPV) Error Count Latch. These bits make up a latch which samples the current value of the Bipolar Violation (BPV) Error Counter (address Y18) on the rising edge of the internal one second timer (ONESEC register address Y11). This latch is cleared with a RESET ($\overline{\text{RESET}}$ pin or RST bit). VEL0 is the least significant bit (LSB).
14	VEL14	
13	VEL13	
12	VEL12	
11	VEL11	
10	VEL10	
9	VEL9	
8	VEL8	
7	VEL7	
6	VEL6	
5	VEL5	
4	VEL4	
3	VEL3	
2	VEL2	
1	VEL1	
0	VEL0	

Table 179 - Bipolar Violation (BPV) Error Count Latch (R/W Address Y29) (E1)

Bit	Name	Functional Description
15	CEL15	CRC-4 Error Count Latch. These bits make up a latch which samples the current value of the CRC-4 Error Counter (address Y19) on the rising edge of the internal <u>one second</u> timer (ONESEC register address Y11). This latch is cleared with a RESET ($\overline{\text{RESET}}$ pin or RST bit). CEL0 is the least significant bit (LSB).
14	CEL14	
13	CEL13	
12	CEL12	
11	CEL11	
10	CEL10	
9	CEL9	
8	CEL8	
7	CEL7	
6	CEL6	
5	CEL5	
4	CEL4	
3	CEL3	
2	CEL2	
1	CEL1	
0	CEL0	

Table 180 - CRC-4 Error Count Latch (R/W Address Y2A) (E1)

Bit	Name	Functional Description
15	BEL7	Frame Alignment Signal (FAS) Bit Error Count Latch. These bits make up a latch which samples the current value of the Frame Alignment Signal (FAS) Bit Error Counter (upper byte of address Y1A) on the rising edge of the internal <u>one second</u> timer (ONESEC register address Y11). This latch is cleared with a RESET ($\overline{\text{RESET}}$ pin or RST bit). BEL0 is the least significant bit (LSB).
14	BEL6	
13	BEL5	
12	BEL4	
11	BEL3	
10	BEL2	
9	BEL1	
8	BEL0	
7	FEL7	Frame Alignment Signal (FAS) Error Count Latch. These bits make up a latch which samples the current value of the Frame Alignment Signal (FAS) Error Counter (lower byte of address Y1A) on the rising edge of the internal <u>one second</u> timer (ONESEC register address Y11). This latch is cleared with a RESET ($\overline{\text{RESET}}$ pin or RST bit). FEL0 is the least significant bit (LSB).
6	FEL6	
5	FEL5	
4	FEL4	
3	FEL3	
2	FEL2	
1	FEL1	
0	FEL0	

Table 181 - Frame Alignment Signal (FAS) Error Count Latch (R/W Address Y2B) (E1)

16.2.6 Interrupt Vector and Interrupt Status Registers (Y3X) Bit Functions

Tables 129 and 130 describes the bit functions of the Interrupt Vectors, while Tables 182 to 185 describe the bit functions of each of the Interrupt Status Registers in the MT9072. Each interrupt status register is repeated for each of the 8 framers (not the Interrupt Vectors). Framer 0 is addressed with Y=0, Framer 1 with Y=1, Framer 2 with Y=2 and so on up to Framer 7 with Y=7 (where Y represents the 4 most significant address bits (MSB) A11-A8). However, since the Interrupt Vectors are common for all eight framers, only addresses 910 and 911 may be used to read from these registers. The (#) indicates that the unused bit position may be read as either a (0) or (1).

Bit	Name	Functional Description
15-9	#	not used.
8	GAI	Go Ahead Interrupt. Indicates a go-ahead pattern (01111111) was detected by the HDLC receiver. This bit is reset after a read.
7	EOPDI	End of Packet Data Interrupt. This bit is set when an end of packet (EOP) byte was written into the RX FIFO by the HDLC receiver. This can be in the form of a flag, an abort sequence or as an invalid packet. This bit is reset after a read.
6	TEOPI	Transmit End of Packet Interrupt. This bit is set when the transmitter has finished sending the closing flag of a packet or after a packet has been aborted. This bit is reset after read.
5	EOPRI	End of Packet Receive Fifo Interrupt. This bit is set when the byte about to be read from the RX FIFO is the last byte of the packet. It is also set if the Rx FIFO is read and there is no data in it. This bit is reset after a read.
4	TXFLI	Transmit FIFO Low Interrupt. This bit is set when the Tx FIFO is emptied below the selected low threshold level. This bit is reset after a read.
3	FAI	Frame Abort: Transmit Interrupt. this bit (FA) is set when a frame abort is received during packet reception. It must be received after a minimum number of bits have been received (26) otherwise it is ignored.
2	TXUNDERI	Transmit Elastic Buffer Empty Interrupt. If high it Indicates that a read by the transmitter was attempted on an empty Tx FIFO. This bit is reset after a read.
1	RXFFI	Receive FIFO is filled above Threshold Interrupt. This bit is set when the Rx FIFO is filled above the selected full threshold level. This bit is reset after a read.
0	RXOVFLI	Receive FiFO Overflow Interrupt. This bit Indicates that the 32 byte RX FIFO overflowed (i.e. an attempt to write to a 32 byte full RX FIFO). The HDLC will always disable the receiver once the receive overflow has been detected. The receiver will be re-enabled upon detection of the next flag, but will overflow again unless the RX FIFO is read. This bit is reset after a read.

Table 182 - HDLC Interrupt Status Register(Y33) (E1)

Bit	Name	Functional Description
15	#	not used.
14	RCRCRI	Remote CRC-4 and RAI Interrupt. This bit is one when the corresponding latched status bit (RCRCRL, register address Y24) is set, and the corresponding mask bit is unmasked (RCRCRM, register address Y44). This bit is cleared when either this register, or the latched status register is read.
13	RSLPI	Receive Slip Interrupt. This bit is one when the corresponding latched status bit (RSLPL, register address Y24) is set, and the corresponding mask bit is unmasked (RSLPM, register address Y44). This bit is cleared when either this register, or the latched status register is read.
12	YI	Receive Y-bit Interrupt. This bit is one when the corresponding latched status bit (YL, register address Y24) is set, and the corresponding mask bit is unmasked (YM, register address Y44). This bit is cleared when either this register, or the latched status register is read.
11	AUXPI	Auxiliary Pattern Interrupt. This bit is one when the corresponding latched status bit (AUXPL, register address Y24) is set, and the corresponding mask bit is unmasked (AUXPM, register address Y44). This bit is cleared when either this register, or the latched status register is read.
10	RAII	Remote Alarm Indication Status Interrupt. This bit is one when the corresponding latched status bit (RAIL, register address Y24) is set, and the corresponding mask bit is unmasked (RAIM, register address Y44). This bit is cleared when either this register, or the latched status register is read.
9	AISI	Alarm Indication Status Signal Interrupt. This bit is one when the corresponding latched status bit (AISL, register address Y24) is set, and the corresponding mask bit is unmasked (AISM, register address Y44). This bit is cleared when either this register, or the latched status register is read.
8	$\overline{\text{AIS16I}}$	Alarm Indication Signal 16 Status Interrupt. This bit is one when the corresponding latched status bit (AIS16L, register address Y24) is set, and the corresponding mask bit is unmasked (AIS16M, register address Y44). This bit is cleared when either this register, or the latched status register is read.
7	LOSSI	Loss of Signal Status Indication Interrupt. This bit is one when the corresponding latched status bit (LOSSL, register address Y24) is set, and the corresponding mask bit is unmasked (LOSSM, register address Y44). This bit is cleared when either this register, or the latched status register is read.
6	RCRC0I	Remote CRC-4 and RAI T10 Interrupt. This bit is one when the corresponding latched status bit (RCRC0L, register address Y24) is set, and the corresponding mask bit is unmasked (RCRC0M, register address Y44). This bit is cleared when either this register, or the latched status register is read.
5	RCRC1I	Remote CRC-4 and RAI T450 Interrupt. This bit is one when the corresponding latched status bit (RCRC1L, register address Y24) is set, and the corresponding mask bit is unmasked (RCRC1M, register address Y44). This bit is cleared when either this register, or the latched status register is read.
4	CEFSI	Consecutively Errored Frame Alignment Signal Interrupt. This bit is one when the corresponding latched status bit (CEFSL, register address Y24) is set, and the corresponding mask bit is unmasked (CEFSM, register address Y44). This bit is cleared when either this register, or the latched status register is read.

Table 183 - Sync, CRC-4 Remote, Alarms, MAS and Phase Interrupt Status Register (Address Y34) (E1)

Bit	Name	Functional Description
3	RFAILI	Remote CRC-4 Multiframe Generator/Detector Failure Interrupt. This bit is one when the corresponding latched status bit (RFAILL, register address Y24) is set, and the corresponding mask bit is unmasked (RFAILM, register address Y44). This bit is cleared when either this register, or the latched status register is read.
2	CSYNCI	Receive CRC-4 Synchronization Interrupt. This bit is one when the corresponding latched status bit (CSYNCL, register address Y24) is set, and the corresponding mask bit is unmasked (CSYNCM, register address Y44). This bit is cleared when either this register, or the latched status register is read.
1	MSYNCI	Receive Multiframe Alignment Interrupt. This bit is one when the corresponding latched status bit (MSYNCL, register address Y24) is set, and the corresponding mask bit is unmasked (MSYNCM, register address Y44). This bit is cleared when either this register, or the latched status register is read.
0	BSYNCI	Receive Basic Frame Alignment Interrupt. This bit is one when the corresponding latched status bit (BSYNCL, register address Y24) is set, and the corresponding mask bit is unmasked (BSYNCM, register address Y44). This bit is cleared when either this register, or the latched status register is read.

Table 183 - Sync, CRC-4 Remote, Alarms, MAS and Phase Interrupt Status Register (Address Y34) (E1)

Bit	Name	Functional Description
15	#	not used.
14	SLOI	Loss of Sync Counter Overflow Interrupt. This bit is one when the corresponding latched status bit (SLOL, register address Y25) is set, and the corresponding mask bit is unmasked (SLOM, register address Y45). This bit is cleared when either this register, or the latched status register is read.
13	FEOI	Frame Alignment Signal (FAS) Error Counter Overflow Interrupt. This bit is one when the corresponding latched status bit (FEOL, register address Y25) is set, and the corresponding mask bit is unmasked (FEOM, register address Y45). This bit is cleared when either this register, or the latched status register is read.
12	FEII	Frame Alignment Signal (FAS) Error Counter Indication Interrupt. This bit is one when the corresponding latched status bit (FEIL, register address Y25) is set, and the corresponding mask bit is unmasked (FEIM, register address Y45). This bit is cleared when either this register, or the latched status register is read.
11	BEOI	Frame Alignment Signal (FAS) Bit Error Counter Overflow Interrupt. This bit is one when the corresponding latched status bit (BEOL, register address Y25) is set, and the corresponding mask bit is unmasked (BEOM, register address Y45). This bit is cleared when either this register, or the latched status register is read.
10	BEII	Frame Alignment Signal (FAS) Bit Error Counter Indication Interrupt. This bit is one when the corresponding latched status bit (BEIL, register address Y25) is set, and the corresponding mask bit is unmasked (BEIM, register address Y45). This bit is cleared when either this register, or the latched status register is read.
9	CEOI	CRC-4 Error Counter Overflow Interrupt. This bit is one when the corresponding latched status bit (CEOL, register address Y25) is set, and the corresponding mask bit is unmasked (CEOM, register address Y45). This bit is cleared when either this register, or the latched status register is read.

Table 184 - Counter Indication and Counter Overflow Interrupt Status Register (Address Y35) (E1)

Bit	Name	Functional Description
8	CEII	CRC-4 Error Counter Indication Interrupt. This bit is one when the corresponding latched status bit (CEIL, register address Y25) is set, and the corresponding mask bit is unmasked (CEIM, register address Y45). This bit is cleared when either this register, or the latched status register is read.
7	VEOI	Bipolar Violation (BPV) Error Counter Overflow Interrupt. This bit is one when the corresponding latched status bit (VEOL, register address Y25) is set, and the corresponding mask bit is unmasked (VEOM, register address Y45). This bit is cleared when either this register, or the latched status register is read.
6	VEII	Bipolar Violation (BPV) Error Counter Indication Interrupt. This bit is one when the corresponding latched status bit (VEIL, register address Y25) is set, and the corresponding mask bit is unmasked (VEIM, register address Y45). This bit is cleared when either this register, or the latched status register is read.
5	EEOI	E-Bit Error Counter Overflow Interrupt. This bit is one when the corresponding latched status bit (EEOL, register address Y25) is set, and the corresponding mask bit is unmasked (EEOM, register address Y45). This bit is cleared when either this register, or the latched status register is read.
4	EEII	E-Bit Error Counter Indication Interrupt. This bit is one when the corresponding latched status bit (EEIL, register address Y25) is set, and the corresponding mask bit is unmasked (EEIM, register address Y45). This bit is cleared when either this register, or the latched status register is read.
3	PCOI	PRBS CRC-4 Counter Overflow Interrupt. This bit is one when the corresponding latched status bit (PCOL, register address Y25) is set, and the corresponding mask bit is unmasked (PCOM, register address Y45). This bit is cleared when either this register, or the latched status register is read.
2	#	not used.
1	PEOI	PRBS Error Counter Overflow Interrupt. This bit is one when the corresponding latched status bit (PEOL, register address Y25) is set, and the corresponding mask bit is unmasked (PEOM, register address Y45). This bit is cleared when either this register, or the latched status register is read.
0	PEII	PRBS Error Counter Indication Interrupt. This bit is one when the corresponding latched status bit (PEIL, register address Y25) is set, and the corresponding mask bit is unmasked (PEIM, register address Y45). This bit is cleared when either this register, or the latched status register is read.

Table 184 - Counter Indication and Counter Overflow Interrupt Status Register (Address Y35) (E1)

Bit	Name	Functional Description
15	#	not used.
14	Sa5VI	Sa5 Value Bit Interrupt. This bit is one when the corresponding latched status bit (Sa5VL, register address Y26) is set, and the corresponding mask bit is unmasked (Sa5VM, register address Y46). This bit is cleared when either this register, or the latched status register is read.
13 12 11 10	Sa6V3I Sa6V2I Sa6V1I Sa6V0I	Sa6 Value Bits 3-0 Interrupt. This bit is one when the corresponding latched status bit (Sa6V*L, register address Y26) is set, and the corresponding mask bit is unmasked (Sa6V*M, register address Y46). This bit is cleared when either this register, or the latched status register is read.
9	Sa6N8I	Eight Consecutive Sa6 Nibbles Interrupt. This bit is one when the corresponding latched status bit (Sa6N8L, register address Y26) is set, and the corresponding mask bit is unmasked (Sa6N8M, register address Y46). This bit is cleared when either this register, or the latched status register is read.
8	Sa6NI	Sa6 Nibble Change Interrupt. This bit is one when the corresponding latched status bit (Sa6NL, register address Y26) is set, and the corresponding mask bit is unmasked (Sa6NM, register address Y46). This bit is cleared when either this register, or the latched status register is read.
7	SaNI	Sa Nibble Change Interrupt. This bit is one when the corresponding latched status bit (SaNL, register address Y26) is set, and the corresponding mask bit is unmasked (SaNM, register address Y46). This bit is cleared when either this register, or the latched status register is read.
6	Sa5TI	Sa5 Bit Change Interrupt. This bit is one when the corresponding latched status bit (Sa5TL, register address Y26) is set, and the corresponding mask bit is unmasked (Sa5TM, register address Y46). This bit is cleared when either this register, or the latched status register is read.
5	SaTI	Sa Bit Change Interrupt. This bit is one when the corresponding latched status bit (SaTL, register address Y26) is set, and the corresponding mask bit is unmasked (SaTM, register address Y46). This bit is cleared when either this register, or the latched status register is read.
4	CASRI	Receive Channel Associated Signaling (CAS) Interrupt. is bit is one when the corresponding latched status bit (CASRL, register address Y24) is set, and the corresponding mask bit is unmasked (CASRM, register address Y44). This bit is cleared when either this register, or the latched status register is read.
3	CALNI	CRC-4 Alignment 2ms Timer Interrupt. This bit is one when the corresponding latched status bit (CALNL, register address Y26) is set, and the corresponding mask bit is unmasked (CALNM, register address Y46). This bit is cleared when either this register, or the latched status register is read.
2	T2I	Timer 2 Interrupt. This bit is one when the corresponding latched status bit (T2L, register address Y26) is set, and the corresponding mask bit is unmasked (T2M, register address Y46). This bit is cleared when either this register, or the latched status register is read.
1	T1I	Timer 1 Interrupt. This bit is one when the corresponding latched status bit (T1L, register address Y26) is set, and the corresponding mask bit is unmasked (T1M, register address Y46). This bit is cleared when either this register, or the latched status register is read.
0	ONESECI	One Second Timer Status Interrupt. This bit is one when the corresponding latched status bit (ONESECL, register address Y26) is set, and the corresponding mask bit is unmasked (ONESECM, register address Y46). This bit is cleared when either this register, or the latched status register is read.

Table 185 - CAS, National, CRC-4 Local and Timer Interrupt Status Register (Address Y36) (E1)

16.2.7 Interrupt Vector Mask and Interrupt Mask Registers (Y4X) Bit Functions

Tables 125 and 126 describe the bit functions of the Interrupt Vector Masks, while tables 186 to 189 describe the bit functions of each of the Interrupt Mask Registers in the MT9072. Each interrupt mask register is repeated for each of the 8 framers (not the Interrupt Vector Masks). Framer 0 is addressed with Y=0, Framer 1 with Y=1, Framer 2 with Y=2 and so on up to Framer 7 with Y=7 (where Y represents the 4 most significant address bits (MSB) A11-A8). In addition, a simultaneous write to all 8 framers is possible by setting the MSB address to Y=8 (1000). However, since the Interrupt Vector Masks are common to all eight framers, only addresses 902 and 903 may be used to read from or write to these registers.

A (0), (1) or (#) in the "Name" column of these tables indicates the state of the data bits after a reset ($\overline{\text{RESET}}$, RSTC or RST). The (#) indicates that a (0) or (1) is possible.

Bit	Name	Functional Description
15-9	#	not used.
8	GAIM (0)	GAIM When unmasked an interrupt is generated when go-ahead pattern (01111111) was detected by the HDLC receiver.
7	EOPDIM (0)	End of Packet Data Interrupt Mask. When unmasked an interrupt is initiated when an end of packet (EOP) byte was written into the RX FIFO by the HDLC receiver.
6	TEOPIM (0)	Transmit End of Packet Interrupt Mask. When unmasked an interrupt is initiated when the byte about to be read from the RX FIFO is the last byte of the packet. An interrupt is also initiated if the Rx FIFO is read and there is no data in it.
5	EOPRIM (0)	End of Packet Received Interrupt Mask. When unmasked an interrupt is initiated when the byte about to be read from the RX FIFO is the last byte of the packet. An interrupt is also initiated if the Rx FIFO is read and there is no data in it.
4	TXFLIM (0)	Transmit Fifo Low Interrupt Mask. When unmasked an interrupt is initiated when the Tx FIFO is emptied below the selected low threshold level.
3	FAIM (0)	Transmit Elastic Buffer full interrupt Mask. When unmasked an interrupt is initiated whenever the transmit elastic buffer is full.If 1 - masked, 0 - unmasked.
2	TXUNDERIM (0)	Transmit Fifo Underrun Interrupt Mask. interrupt is initiated for TX FIFO underrun indication.
1	RXFFIM (0)	Receive Fifo full Threshold interrupt Mask. When unmasked an interrupt is initiated whenever the Rx FIFO is filled above the selected full threshold level.
0	RXOVFLIM (0)	Receive Fifo Overflow Interrupt Mask. When unmasked an interrupt is initiated whenever the 16 byte RX FIFO overflowed (i.e. an attempt to write to a 16 byte full RX FIFO).

Table 186 - HDLC Interrupt Mask Register (Address Y43) (E1)

Bit	Name	Functional Description
15	#	not used.
14	RCRCRM (0)	Remote CRC-4 and RAI Mask. This is the mask bit for the RCRCRI interrupt status bit in the Sync (Sync, CRC-4 Remote, Alarms, MAS and Phase) Interrupt Status Register (address Y34). If this mask bit is one, the corresponding interrupt bit will remain inactive. If this mask bit is zero, the corresponding interrupt bit will function normally.
13	RSLPM (0)	Receive Slip Mask. This is the mask bit for the RSLPI interrupt status bit in the Sync (Sync, CRC-4 Remote, Alarms, MAS and Phase) Interrupt Status Register (address Y34). If this mask bit is one, the corresponding interrupt bit will remain inactive. If this mask bit is zero, the corresponding interrupt bit will function normally.
12	YM (0)	Receive Y-bit Mask. This is the mask bit for the YI interrupt status bit in the Sync (Sync, CRC-4 Remote, Alarms, MAS and Phase) Interrupt Status Register (address Y34). If this mask bit is one, the corresponding interrupt bit will remain inactive. If this mask bit is zero, the corresponding interrupt bit will function normally.
11	AUXPM (0)	Auxiliary Pattern Mask. This is the mask bit for the AUXPI interrupt status bit in the Sync (Sync, CRC-4 Remote, Alarms, MAS and Phase) Interrupt Status Register (address Y34). If this mask bit is one, the corresponding interrupt bit will remain inactive. If this mask bit is zero, the corresponding interrupt bit will function normally.
10	RAIM (0)	Remote Alarm Indication Status Mask. This is the mask bit for the RAI interrupt status bit in the Sync (Sync, CRC-4 Remote, Alarms, MAS and Phase) Interrupt Status Register (address Y34). If this mask bit is one, the corresponding interrupt bit will remain inactive. If this mask bit is zero, the corresponding interrupt bit will function normally.
9	AISM (0)	Alarm Indication Status Signal Mask. This is the mask bit for the AISI interrupt status bit in the Sync (Sync, CRC-4 Remote, Alarms, MAS and Phase) Interrupt Status Register (address Y34). If this mask bit is one, the corresponding interrupt bit will remain inactive. If this mask bit is zero, the corresponding interrupt bit will function normally.
8	$\overline{\text{AIS16M}}$ (0)	Alarm Indication Signal 16 Status Mask. This is the mask bit for the $\overline{\text{AIS16I}}$ interrupt status bit in the Sync (Sync, CRC-4 Remote, Alarms, MAS and Phase) Interrupt Status Register (address Y34). If this mask bit is one, the corresponding interrupt bit will remain inactive. If this mask bit is zero, the corresponding interrupt bit will function normally.
7	LOSSM (0)	Loss of Signal Status Indication Mask. This is the mask bit for the LOSSI interrupt status bit in the Sync (Sync, CRC-4 Remote, Alarms, MAS and Phase) Interrupt Status Register (address Y34). If this mask bit is one, the corresponding interrupt bit will remain inactive. If this mask bit is zero, the corresponding interrupt bit will function normally.
6	RCRC0M (0)	Remote CRC-4 and RAI T10 Mask. This is the mask bit for the RCRC0I interrupt status bit in the Sync (Sync, CRC-4 Remote, Alarms, MAS and Phase) Interrupt Status Register (address Y34). If this mask bit is one, the corresponding interrupt bit will remain inactive. If this mask bit is zero, the corresponding interrupt bit will function normally.
5	RCRC1M (0)	Remote CRC-4 and RAI T450 Mask. This is the mask bit for the RCRC1I interrupt status bit in the Sync (Sync, CRC-4 Remote, Alarms, MAS and Phase) Interrupt Status Register (address Y34). If this mask bit is one, the corresponding interrupt bit will remain inactive. If this mask bit is zero, the corresponding interrupt bit will function normally.
4	CEFSM (0)	Consecutively Errored Frame Alignment Signal Mask. This is the mask bit for the CEFSI interrupt status bit in the Sync (Sync, CRC-4 Remote, Alarms, MAS and Phase) Interrupt Status Register (address Y34). If this mask bit is one, the corresponding interrupt bit will remain inactive. If this mask bit is zero, the corresponding interrupt bit will function normally.

Table 187 - Sync (Sync, CRC-4 Remote, Alarms, MAS and Phase) Interrupt Mask Register (Address Y44) (E1)

Bit	Name	Functional Description
3	RFAILM (0)	Remote CRC-4 Multiframe Generator/Detector Failure Mask. This is the mask bit for the RFAILI interrupt status bit in the Sync (Sync, CRC-4 Remote, Alarms, MAS and Phase) Interrupt Status Register (address Y34). If this mask bit is one, the corresponding interrupt bit will remain inactive. If this mask bit is zero, the corresponding interrupt bit will function normally.
2	CSYNCM (0)	Receive CRC-4 Synchronization Mask. This is the mask bit for the CSYNCI interrupt status bit in the Sync (Sync, CRC-4 Remote, Alarms, MAS and Phase) Interrupt Status Register (address Y34). If this mask bit is one, the corresponding interrupt bit will remain inactive. If this mask bit is zero, the corresponding interrupt bit will function normally.
1	MSYNCM (0)	Receive Multiframe Alignment Mask. This is the mask bit for the MSYNCI interrupt status bit in the Sync (Sync, CRC-4 Remote, Alarms, MAS and Phase) Interrupt Status Register (address Y34). If this mask bit is one, the corresponding interrupt bit will remain inactive. If this mask bit is zero, the corresponding interrupt bit will function normally.
0	BSYNCM (0)	Receive Basic Frame Alignment Mask. This is the mask bit for the BSYNCI interrupt status bit in the Sync (Sync, CRC-4 Remote, Alarms, MAS and Phase) Interrupt Status Register (address Y34). If this mask bit is one, the corresponding interrupt bit will remain inactive. If this mask bit is zero, the corresponding interrupt bit will function normally.

Table 187 - Sync (Sync, CRC-4 Remote, Alarms, MAS and Phase) Interrupt Mask Register (Address Y44) (E1)

Bit	Name	Functional Description
15	#	not used.
14	SLOM (0)	Loss of Sync Counter Overflow Mask. This is the mask bit for the SLOI interrupt status bit in the Counter (Counter Indication and Counter Overflow) Interrupt Status Register (address Y35). If this mask bit is one, the corresponding interrupt bit will remain inactive. If this mask bit is zero, the corresponding interrupt bit will function normally.
13	FEOM (0)	Frame Alignment Signal (FAS) Error Counter Overflow Mask. This is the mask bit for the FEOI interrupt status bit in the Counter (Counter Indication and Counter Overflow) Interrupt Status Register (address Y35). If this mask bit is one, the corresponding interrupt bit will remain inactive. If this mask bit is zero, the corresponding interrupt bit will function normally.
12	FEIM (0)	Frame Alignment Signal (FAS) Error Counter Indication Mask. This is the mask bit for the FEII interrupt status bit in the Counter (Counter Indication and Counter Overflow) Interrupt Status Register (address Y35). If this mask bit is one, the corresponding interrupt bit will remain inactive. If this mask bit is zero, the corresponding interrupt bit will function normally.
11	BEOM (0)	Frame Alignment Signal (FAS) Bit Error Counter Overflow Mask. This is the mask bit for the BEOI interrupt status bit in the Counter (Counter Indication and Counter Overflow) Interrupt Status Register (address Y35). If this mask bit is one, the corresponding interrupt bit will remain inactive. If this mask bit is zero, the corresponding interrupt bit will function normally.
10	BEIM (0)	Frame Alignment Signal (FAS) Bit Error Counter Indication Mask. This is the mask bit for the BEII interrupt status bit in the Counter (Counter Indication and Counter Overflow) Interrupt Status Register (address Y35). If this mask bit is one, the corresponding interrupt bit will remain inactive. If this mask bit is zero, the corresponding interrupt bit will function normally.

Table 188 - Counter (Counter Indication and Counter Overflow) Interrupt Mask Register (Address Y45) (E1)

Bit	Name	Functional Description
9	CEOM (0)	CRC-4 Error Counter Overflow Mask. This is the mask bit for the CEOI interrupt status bit in the Counter (Counter Indication and Counter Overflow) Interrupt Status Register (address Y35). If this mask bit is one, the corresponding interrupt bit will remain inactive. If this mask bit is zero, the corresponding interrupt bit will function normally.
8	CEIM (0)	CRC-4 Error Counter Indication Mask. This is the mask bit for the CEII interrupt status bit in the Counter (Counter Indication and Counter Overflow) Interrupt Status Register (address Y35). If this mask bit is one, the corresponding interrupt bit will remain inactive. If this mask bit is zero, the corresponding interrupt bit will function normally.
7	VEOM (0)	Bipolar Violation (BPV) Error Counter Overflow Mask. This is the mask bit for the VEOI interrupt status bit in the Counter (Counter Indication and Counter Overflow) Interrupt Status Register (address Y35). If this mask bit is one, the corresponding interrupt bit will remain inactive. If this mask bit is zero, the corresponding interrupt bit will function normally.
6	VEIM (0)	Bipolar Violation (BPV) Error Counter Indication Mask. This is the mask bit for the VEII interrupt status bit in the Counter (Counter Indication and Counter Overflow) Interrupt Status Register (address Y35). If this mask bit is one, the corresponding interrupt bit will remain inactive. If this mask bit is zero, the corresponding interrupt bit will function normally.
5	EEOM (0)	E-Bit Error Counter Overflow Mask. This is the mask bit for the EEOI interrupt status bit in the Counter (Counter Indication and Counter Overflow) Interrupt Status Register (address Y35). If this mask bit is one, the corresponding interrupt bit will remain inactive. If this mask bit is zero, the corresponding interrupt bit will function normally.
4	EEIM (0)	E-Bit Error Counter Indication Mask. This is the mask bit for the EEII interrupt status bit in the Counter (Counter Indication and Counter Overflow) Interrupt Status Register (address Y35). If this mask bit is one, the corresponding interrupt bit will remain inactive. If this mask bit is zero, the corresponding interrupt bit will function normally.
3	PCOM (0)	PRBS CRC-4 Counter Overflow Mask. This is the mask bit for the PCOI interrupt status bit in the Counter (Counter Indication and Counter Overflow) Interrupt Status Register (address Y35). If this mask bit is one, the corresponding interrupt bit will remain inactive. If this mask bit is zero, the corresponding interrupt bit will function normally.
2	(0)	not used.
1	PEOM (0)	PRBS Error Counter Overflow Mask. This is the mask bit for the PEOI interrupt status bit in the Counter (Counter Indication and Counter Overflow) Interrupt Status Register (address Y35). If this mask bit is one, the corresponding interrupt bit will remain inactive. If this mask bit is zero, the corresponding interrupt bit will function normally.
0	PEIM (0)	PRBS Error Counter Indication Mask. This is the mask bit for the PEII interrupt status bit in the Counter (Counter Indication and Counter Overflow) Interrupt Status Register (address Y35). If this mask bit is one, the corresponding interrupt bit will remain inactive. If this mask bit is zero, the corresponding interrupt bit will function normally.

Table 188 - Counter (Counter Indication and Counter Overflow) Interrupt Mask Register (Address Y45) (E1)

Bit	Name	Functional Description
15	#	not used.
14	Sa5VM	Sa5 Value Bit Mask. This is the mask bit for the Sa5VI interrupt status bit in the National (CAS, National, CRC-4 Local and Timers) Interrupt Status Register (address Y36). If this mask bit is one, the corresponding interrupt bit will remain inactive. If this mask bit is zero, the corresponding interrupt bit will function normally.
13 13 12 11	Sa6V3M Sa6V2M Sa6V1M Sa6V0M (0000)	Sa6 Value Bits 3-0 Mask. This is the mask bit for the Sa6V*I interrupt status bit in the National (CAS, National, CRC-4 Local and Timers) Interrupt Status Register (address Y36). If this mask bit is one, the corresponding interrupt bit will remain inactive. If this mask bit is zero, the corresponding interrupt bit will function normally.
10	#	not used.
9	Sa6N8M (0)	Eight Consecutive Sa6 Nibbles Mask. This is the mask bit for the Sa6N8I interrupt status bit in the National (CAS, National, CRC-4 Local and Timers) Interrupt Status Register (address Y36). If this mask bit is one, the corresponding interrupt bit will remain inactive. If this mask bit is zero, the corresponding interrupt bit will function normally.
8	Sa6NM (0)	Sa6 Nibble Change Mask. This is the mask bit for the Sa6NI interrupt status bit in the National (CAS, National, CRC-4 Local and Timers) Interrupt Status Register (address Y36). If this mask bit is one, the corresponding interrupt bit will remain inactive. If this mask bit is zero, the corresponding interrupt bit will function normally.
7	SaNm (0)	Sa Nibble Change Mask. This is the mask bit for the SaNI interrupt status bit in the National (CAS, National, CRC-4 Local and Timers) Interrupt Status Register (address Y36). If this mask bit is one, the corresponding interrupt bit will remain inactive. If this mask bit is zero, the corresponding interrupt bit will function normally.
6	Sa5TM (0)	Sa5 Bit Change Mask. This is the mask bit for the Sa5TI interrupt status bit in the National (CAS, National, CRC-4 Local and Timers) Interrupt Status Register (address Y36). If this mask bit is one, the corresponding interrupt bit will remain inactive. If this mask bit is zero, the corresponding interrupt bit will function normally.
5	SaTM (0)	Sa Bit Change Mask. This is the mask bit for the SaTI interrupt status bit in the National (CAS, National, CRC-4 Local and Timers) Interrupt Status Register (address Y36). If this mask bit is one, the corresponding interrupt bit will remain inactive. If this mask bit is zero, the corresponding interrupt bit will function normally.
4	CASRM (0)	Receive Channel Associated Signaling (CAS) Mask. This is the mask bit for the CASRI interrupt status bit in the National (CAS, National, CRC-4 Local and Timers) Interrupt Status Register (address Y36). If this mask bit is one, the corresponding interrupt bit will remain inactive. If this mask bit is zero, the corresponding interrupt bit will function normally.
3	CALNM (0)	CRC-4 Alignment 2ms Timer Mask. This is the mask bit for the CALNI interrupt status bit in the National (CAS, National, CRC-4 Local and Timers) Interrupt Status Register (address Y36). If this mask bit is one, the corresponding interrupt bit will remain inactive. If this mask bit is zero, the corresponding interrupt bit will function normally.
2	T2M (0)	Timer 2 Mask. This is the mask bit for the T2I interrupt status bit in the National (CAS, National, CRC-4 Local and Timers) Interrupt Status Register (address Y36). If this mask bit is one, the corresponding interrupt bit will remain inactive. If this mask bit is zero, the corresponding interrupt bit will function normally.

Table 189 - National (CAS, National, CRC-4 Local and Timers) Interrupt Mask Register (Address Y46) (E1)

Bit	Name	Functional Description
1	T1M (0)	Timer 1 Mask. This is the mask bit for the T1I interrupt status bit in the National (CAS, National, CRC-4 Local and Timers) Interrupt Status Register (address Y36). If this mask bit is one, the corresponding interrupt bit will remain inactive. If this mask bit is zero, the corresponding interrupt bit will function normally.
0	ONESECM (0)	One Second Timer Status Mask. This is the mask bit for the ONESECI interrupt status bit in the National (CAS, National, CRC-4 Local and Timers) Interrupt Status Register (address Y36). If this mask bit is one, the corresponding interrupt bit will remain inactive. If this mask bit is zero, the corresponding interrupt bit will function normally.

Table 189 - National (CAS, National, CRC-4 Local and Timers) Interrupt Mask Register (Address Y46) (E1)

16.2.8 Transmit CAS (ABCD) Data Registers (Y51 - Y6F) Bit Functions

Table 190 describes the bit functions of each (30 registers in total, one register for each PCM 30 channel) of the Transmit CAS Data Registers in the MT9072. Each register is repeated for each of the 8 framers. Framer 0 is addressed with Y=0, Framer 1 with Y=1, Framer 2 with Y=2 and so on up to Framer 7 with Y=7 (where Y represents the 4 most significant address bits (MSB) A11-A8). In addition, a simultaneous write to all 8 framers is possible by setting the MSB address to Y=8 (1000). Note that if corresponding MPST bit in the per timeslot control is not set this memory will be constantly updated with CSTi values. Hence to use this registers for any channels the corresponding MPST bit has to be set.

A (0), (1) or (#) in the "Name" column of these tables indicates the state of the data bits after a reset ($\overline{\text{RESET}}$, RSTC or RST). The (#) indicates that a (0) or (1) is possible.

Bit	Name	Functional Description
15-4	(##### ##### #####)	not used.
3	A(n) (#)	Transmit Channel Associated Signaling (CAS) Signaling Bits for Channel 1 to 30.
2	B(n) (#)	Bits for n=1 to 15 correspond to channel 1 to 15 and are transmitted on the PCM30 link in timeslot 16 in bit positions one to four in frame n.
1	C(n) (#)	Bits for n=17 to 31 correspond to channel 16 to 30 and are transmitted on the PCM30 link in timeslot 16 in bit positions five to eight in frame n -16.
0	D(n) (#)	The corresponding CASS(n) bit must be one for this to function.
For these functions to be valid, CAS mode must be selected (CSIG=0 register address Y03), and the timeslot control must be selected (CASS(n)=1 register address Y90 to YAF).		

Table 190 - Channel n, Transmit CAS Data Register (Address Y51-Y6F) (E1)

16.2.9 Receive CAS (ABCD) Data Registers (Y71 - Y8F) Bit Functions

Table 191 describes the bit functions of each (30 registers in total, one register for each PCM 30 channel) of the Receive CAS Data Registers in the MT9072. Each register is repeated for each of the 8 framers. Framer 0 is addressed with Y=0, Framer 1 with Y=1, Framer 2 with Y=2 and so on up to Framer 7 with Y=7 (where Y represents the 4 most significant address bits (MSB) A11-A8).

A (0), (1) or (#) in the “Name” column of these tables indicates the state of the data bits after a reset ($\overline{\text{RESET}}$, RSTC or RST). The (#) indicates that a (0) or (1) is possible.

Bit	Name	Functional Description
15-4	(#### #### ####)	not used.
3	$A_{(n)}$ (#)	Receive Channel Associated Signaling (CAS) Signaling Bits for Channel 1 to 30. Bits for n=1 to 15 correspond to channel 1 to 15 and are received on the PCM30 link in timeslot 16 in bit positions one to four in frame n. Bits for n=17 to 31 correspond to channel 16 to 30 and are received on the PCM30 link in timeslot 16 in bit positions five to eight in frame n -16.
2	$B_{(n)}$ (#)	
1	$C_{(n)}$ (#)	
0	$D_{(n)}$ (#)	
For these functions to be valid, CAS mode must be selected (CSIG=0 register address Y03).		

Table 191 - Channel n, Receive CAS Data Register (Address Y71-Y8F)

16.2.10 Timeslot 0-31 Control Registers (Y90 - YAF) Bit Functions

Table 191 describes the bit functions of each (32 registers in total, one register for each timeslot) of the Timeslot Control Registers in the MT9072. Each register is repeated for each of the 8 framers. Framer 0 is addressed with Y=0, Framer 1 with Y=1, Framer 2 with Y=2 and so on up to Framer 7 with Y=7 (where Y represents the 4 most significant address bits (MSB) A11-A8). In addition, a simultaneous write to all 8 framers is possible by setting the MSB address to Y=8 (1000). Note that timeslots 0 to 15 are accommodated by addresses Y90 to Y9F respectively, and timeslots 16 to 31 are accommodated by addresses YA0 to YAF respectively.

A (0), (1) or (#) in the "Name" column of these tables indicates the state of the data bits after a reset ($\overline{\text{RESET}}$, RSTC or RST). The (#) indicates that a (0) or (1) is possible.

Bit	Name	Functional Description
15-10	(##### #####)	not used.
9	RADI(n) (0)	Receive Alternate Digit Inversion. the data received on DSTo timeslot n from the received PCM30 link timeslot n has every second bit inverted. If zero, this bit has no effect on channel data.
8	MPDR (0)	Micro Port Data Receive. Setting this bit freezes the receive data for a given channel After putting the freeze the data (Y09).
7	CASS(n) (0)	Channel Associated Signaling (CAS) Source. Selects the source for the CAS data (A,B,C,D) on the transmit PCM30 link in bit positions one to four, and five to eight of timeslot 16 in frames 1 to 15. If zero, ST-BUS (CSTi) is selected as the source. If one, data register (register address Y5,6n) is selected as the source. For n=1 to 15, the CASS(n) bit corresponds to timeslot n which corresponds to channel n. For n=17 to 31, the CASS(n) bit corresponds to timeslot n which corresponds to channel n-1.
6	TADI(n) (0)	Transmit Alternate Digit Inversion. If one, the data sourced from DSTi timeslot n (n = 0 to 31) to the transmit PCM30 link timeslot n has every second bit inverted, If zero, this bit has no effect on channel data.
5	RTSL(n) (0)	Remote Timeslot Loopback. If one, the data from the received PCM30 link timeslot n (n = 0 to 31) is output on DSTo timeslot n and is also looped back to the transmit PCM30 link timeslot n. If zero, the loopback is disabled.
4	LTSL(n) (0)	Local Timeslot Loopback. If one, the data sourced from DSTi timeslot n (n = 0 to 31) to the transmit PCM30 link timeslot n is also looped back to DSTo timeslot n. If zero, this loopback is disabled.
3	TTST(n) (0)	Transmit Test. If one and control bit ADSEQ (register address Y01) is one, the A-law digital milliwatt will be transmitted in PCM30 timeslot n. When one and ADSEQ is zero, a Pseudo-Random Bit Sequence (PRBS $2^{15}-1$) will be transmitted in PCM30 timeslot n. More than one timeslot may be activated at once. If zero, neither of these test signals will be connected to timeslot n.
2	RRST(n) (0)	Receive Test. If one and control bit ADSEQ (register address Y01) is one, the A-law digital milliwatt will be transmitted in DSTo timeslot n. When one and ADSEQ is zero, a Pseudo Random Bit Sequence (PRBS $2^{15}-1$) receiver will be connected to DSTo timeslot n. This receiver circuit will synchronize to the transmit PRBS signal and perform a bit comparison of the two sequences. If zero, neither of these test signals will be connected to the corresponding timeslot.
1	MPDT(0)	Micro Port Data Transmit. Setting this bit allows for the transmit data for a given channel to be replaced by the idle code(Y0A). The idle code can be written by the micro port for trunk conditioning applications. The data in Y0A will replace the appropriate PCM30 channel.
0	(#)	not used.

Note: For address Y90 (n=0), set all control bits to 0.

Table 192 - Timeslot (TS) n (n = 0 to 31) Control Register (Address Y90 (TS0) to YAF(TS31)) (E1)

16.2.11 Transmit National Bit RN Data Registers (YB0- YB4) Bit Functions

Table 192 describes the bit functions of each (5 registers in total, one register for each bit position) of the Transmit National Bits Data Registers in the MT9072. Each register is repeated for each of the 8 framers. Framer 0 is addressed with Y=0, Framer 1 with Y=1, Framer 2 with Y=2 and so on up to Framer 7 with Y=7 (where Y represents the 4 most significant address bits (MSB) A11-A8). In addition, a simultaneous write to all 8 framers is possible by setting the MSB address to Y=8 (1000). Each register contains one byte (8-bits) of data corresponding to eight frames of a particular bit position in timeslot 0. There are 5 registers in total containing 5 bytes of data, occupying addresses YB0 to YB4. Address YB0 corresponds to bit position 4 (TN0=Sa4) and address YC4 corresponding to bit position 8 (TN4=Sa8).

A (0), (1) or (#) in the “Name” column of these tables indicates the state of the data bits after a reset ($\overline{\text{RESET}}$, RSTC or RST). The (#) indicates that a (0) or (1) is possible.

Bit	Name	Functional Description
15-8	(#### ####)	not used.
7 6 5 4 3 2 1 0	TNnF1 TNnF3 TNnF5 TNnF7 TNnF9 TNnF11 TNnF13 TNnF15 (0000 0000)	Transmit National Bit TNnFm (n = 0 to 4, m = 1, 3, 5 etc. to 15). This bit is transmitted on the PCM30 link, in bit position n+4 of Timeslot 0 during Frame m (non-frame alignment signal (NFAS) frames) when CRC-4 multiframe alignment is used, or of consecutive odd frames when CRC-4 multiframe alignment is not used. Bit TNnFm is sourced from register address YFn as follows. TN0Fm = Address YF8 corresponds to transmit national bits Sa4Fm TN1Fm = Address YF9 corresponds to transmit national bits Sa5Fm TN2Fm = Address YFA corresponds to transmit national bits Sa6Fm TN3Fm = Address YFB corresponds to transmit national bits Sa7Fm TN4Fm = Address YFC corresponds to transmit national bits Sa8Fm

Table 193 - Transmit National Bits (Sa4 - Sa8) TNn (n = 0 to 4) Data Register (R/W Address YB0 to YB4) (E1)

16.2.12 Receive National Bit RN Data Registers (YC0- YC4) Bit Functions

Table 193 describes the bit functions of each (5 registers in total, one register for each bit position) of the Receive National Bits Data Registers in the MT9072. Each register is repeated for each of the 8 framers. Framer 0 is addressed with Y=0, Framer 1 with Y=1, Framer 2 with Y=2 and so on up to Framer 7 with Y=7 (where Y represents the 4 most significant address bits (MSB) A11-A8). Each register contains one byte (8-bits) of data corresponding to eight frames of a particular bit position in timeslot 0. There are 5 registers in total containing 5 bytes of data, occupying addresses YC0 to YC4 Address YC0 corresponds to bit position 4 (RN0=Sa4) and address YC4 corresponding to bit position 8 (RN4=Sa8).

A (0), (1) or (#) in the "Name" column of these tables indicates the state of the data bits after a reset ($\overline{\text{RESET}}$, RSTC or RST). The (#) indicates that a (0) or (1) is possible.

Bit	Name	Functional Description
15-8	(#### ####)	not used.
7 6 5 4 3 2 1 0	RNnF1 RNnF3 RNnF5 RNnF7 RNnF9 RNnF11 RNnF13 RNnF15 (0000 0000)	Receive National Bit RNnFm (n = 0 to 4, m = 1, 3, 5 etc. to 15). This bit is received from the PCM30 link, in bit position n+4 of Timeslot 0 during Frame m (non-frame alignment signal (NFAS) frames) when CRC-4 multiframe alignment is used, or of consecutive odd frames when CRC-4 multiframe alignment is not used. Bit RNnFm is sourced to register address YCn as follows. RN0Fm = Address YC0 corresponds to receive national bit Sa4Fm RN1Fm = Address YC1 corresponds to receive national bit Sa5Fm RN2Fm = Address YC2 corresponds to receive national bit Sa6Fm RN3Fm = Address YC3 corresponds to receive national bit Sa7Fm RN4Fm = Address YC4 corresponds to receive national bit Sa8Fm

Table 194 - Receive National Bits (Sa4 - Sa8) RNn (n = 0 to 4) Data Register (R/W Address YC0 to YC4) (E1)

16.2.13 Master Control Registers (YF0 - YF6) Bit Functions

Tables 194 to 197 describe the bit functions of each of the Master Control Registers in the MT9072 in E1 Mode(YF0 to YF6). Each register is repeated for each of the 8 framers. Framer 0 is addressed with Y=0, Framer 1 with Y=1, Framer 2 with Y=2 and so on up to Framer 7 with Y=7 (where Y represents the 4 most significant address bits (MSB) A11-A8). In addition, a simultaneous write to all 8 framers is possible by setting the MSB address to Y=8 (1000).

A (0), (1) or (#) in the "Name" column of these tables indicates the state of the data bits after a reset ($\overline{\text{RESET}}$, RSTC or RST). The (#) indicates that a (0) or (1) is possible.

Bit	Name	Functional Description
15-11	#	not used.
10	ADREC (0)	Address Recognition. When high, this bit will enable address recognition. This forces the receiver to recognize only those packets having the unique address as programmed in the Receive Address Recognition Registers or if the address is an All Call Address.
9	RXEN (0)	Receive Enable. When low this bit will disable the HDLC receiver. The receiver will disable after the rest of the packet presently being received is finished. The receiver's internal clock is disabled. When high the receiver will be immediately enabled (depending on the state of RXCEN input) and will begin searching for flags, Go-aheads etc.
8	TXEN (0)	Transmit Enable. When low this bit will disable the HDLC transmitter. The transmitter will disable after the completion of the packet presently being transmitted. The transmitter's internal clock is disabled. When high the transmitter will be immediately enabled (depending on the state of the TXCEN input) and will begin transmitting data, or go to a mark idle or interframe time fill state.
7	EOP (0)	End of Packet When set this bit will indicate an end of packet byte to the transmitter, which will transmit an FCS following this byte. This facilitates loading of multiple packets into TX FIFO. Reset automatically after a write to the TX FIFO occurs.
6	FA (0)	Framer Abort. Forms a tag on the next byte written to the TX FIFO, and when set will indicate to the transmitter that it should abort the packet in which that byte is being transmitted. Reset automatically after a write to the TX FIFO.
5	MI (0)	Mark-Idle. When low, the transmitter will be in an idle state. When high it is in an interframe time fill state. These two states will only occur when the TX FIFO is empty.
4	CYCLE (0)	Cycle. When high, this bit will cause the transmit byte count to cycle through the value loaded into the Transmit Byte Count Register.
3	TCRCI (0)	Transmit CRC Inhibit. When high, this bit will inhibit transmission of the CRC. That is, the transmitter will not insert the computed CRC onto the bit stream after seeing the EOP tag byte. This is used in V.120 terminal adaptation for synchronous protocol sensitive UI frames.
2	SEVEN (0)	Seven. When high, this bit will enable seven bits of address recognition in the first address byte. The received address byte must have bit 0 equal to 1 which indicates a single address byte is being received.
1	RXFRST (0)	Rx Fifo Reset. When high, the RX FIFO will be reset. This causes the receiver to be disabled until the next reception of a flag. The status register will identify the FIFO as being empty. However, the actual bit values in the RX FIFO will not be reset.
0	TXFRST (0)	Transmit FIFO Reset. When high, the TX FIFO will be reset. The Status Register will identify the FIFO as being empty. This bit will be reset when data is written to the TX FIFO. However, the actual bit values of data in the TX FIFO will not be reset.

Table 195 - HDLC Control1(YF2) (E1)

Bit	Name	Functional Description
15-6	#	not used.
5	HRST (0)	HDLC Reset. When this bit is high, the HDLC and HDLC registers will be reset (HDLC Control, HDLC Test Control, Address Recognition Byte). This is similar to RESET being applied, the only difference being that this bit will not be reset. This bit can only be reset by writing a zero to this location or applying RESET.
4	RTLOOP (0)	Receive Transmit Loopback. When this bit is high, receive to transmit HDLC loopback will be activated. Receive data, including end of packet indication, but not including flags or CRC, will be written to the TX FIFO as well as the RX FIFO. When the transmitter is enabled, this data will be transmitted as though written by the microprocessor. Both good and bad packets will be looped back. Receive to transmit loopback may also be accomplished by reading the RX FIFO using the microprocessor and writing these bytes, with appropriate tags, into the TX FIFO.
3	CRCTST (0)	CRC Test. This bit allows direct access to the CRC Comparison Register in the receiver through the serial interface. After testing is enabled, serial data is clocked in until the data aligns with the internal comparison (16 RXC clock cycles) and then the clock is stopped. The expected pattern is F0B8 hex. Each bit of the CRC can be corrupted to allow more efficient testing.
2	FTST (0)	Fifo Test. This bit allows the writing to the RX FIFO and reading of the TX FIFO through the microprocessor to allow more efficient testing of the FIFO status/interrupt functionality. This is done by making a TX FIFO write become a RX FIFO write and a RX FIFO read become a TX FIFO read. In addition, EOP/FA and RQ8/RQ9 are re-defined to be accessible (i.e. RX write causes EOP/FA to go to RX fifo input; TX read looks at output of TX fifo through RQ8/RQ9 bits).
1	ADTST (0)	Address Recognition Test. This bit allows direct access to the Address Recognition Registers in the receiver through the serial interface to allow more efficient testing. After address testing is enabled, serial data is clocked in until the data aligns with the internal address comparison (16 RXc clock cycles) and then clock is stopped. Then the VADDR bit in Y1C can be checked.
0	HLOOP (0)	HDLC Loopback. When high, transmit to receive HDLC loopback will be activated. The packetized transmit data will be looped back to the receive input. RXEN and TXEN bits must also be enabled.

Table 196 - HDLC Test Control(YF3) (E1)

Bit	Name	Functional Description
15-8	#	not used.
7 - 0	BIT7-0 (00000000)	This eight bit word is tagged with the two status bits from control register 1 (EOP and FA), and the resulting 10 bit word is written to the TX FIFO. The FIFO status is not changed immediately after a write or read occurs. It is updated after the data has settled and the transfer to the last available position has finished. Note that when the HDLC is connected to a T1 channel, the least significant bit in the FIFO is sent first.

Table 197 - TX Fifo Write Register(YF5) (E1)

Bit	Name	Functional Description
15-8	#	not used.
7 - 0	CNT7-0 (00000000)	The Transmit Byte Count Register indicating the length of the data portion of the packet about to be transmitted. This is the size of the data and not the address, flags or FCS. The Transmit Byte Counter position Y1C determines the number of bytes that have been sent from the Transmit FIFO.

Table 198 - TX Byte Count Register(YF6) (E1)

16.2.14 Global Control and Status Registers(900-91F) Bit Functions

The Global Control and Status Registers are common to the T1 and E1 operation. The global registers are accessed by address hex 9xx (A₁₁ and A₈ being high and A₁₀ and A₉ being low)

Bit	Name	Functional Description												
15	T1E0 (1)	T1E0. This bit determines if the chip will operate in T1 or E1 mode for all 8 framers. If the value of this bit is changed the chip is reset in E1 or T1 default register mode. If the bit is set to 1, all the framer register values are set to T1 defaults. For a setting of 0 the register values are set to E1 defaults. This action takes approximately 34 1.5444 clock cycles. Hence any writes to registers should be done on the next 125 usec frame after setting or clearing this bit.												
14	STBUS (0)	ST-BUS Enable. If zero, ST-BUS timing is enabled. If one, GCI timing is enabled (only available for 2.048Mb/s mode). See Figures 24-31.												
13-5	#	not used												
4	CK1	Clock Rate. These clock select bits determine the system clock at the CKi pin and the receive frame pulse at the FPi pin as follows (See Figures 24 to 31): <table border="1" style="margin-left: 20px;"> <thead> <tr> <th>CK1</th> <th>Clock</th> <th>Frame Pulse</th> <th>System Bus</th> </tr> </thead> <tbody> <tr> <td>0</td> <td>4.096MHz</td> <td>2.048Mb/s</td> <td>2.048Mb/s</td> </tr> <tr> <td>1</td> <td>16.384MHz</td> <td>8.192Mb/s</td> <td>8.192Mb/s</td> </tr> </tbody> </table>	CK1	Clock	Frame Pulse	System Bus	0	4.096MHz	2.048Mb/s	2.048Mb/s	1	16.384MHz	8.192Mb/s	8.192Mb/s
CK1	Clock	Frame Pulse	System Bus											
0	4.096MHz	2.048Mb/s	2.048Mb/s											
1	16.384MHz	8.192Mb/s	8.192Mb/s											
3-1	#	not used.												
0	RSTC (0)	Common Reset. When this bit is changed from zero to one, all <u>eight framers</u> will reset to their default T1 mode. This software reset has the same effect as the RESET pin. See the Reset Operation section for the default settings.												

Table 199 - Global Control0 Register (R/W Address 900) (E1)

Bit	Name	Functional Description
15-11	CHANNUM (00000)	Channel Number. These 5 bits determine the channel that is used for updating of the ST-BUS Analyzer buffer.
10-8	#	not used.
7-6	STRNUM (00000)	Stream Number. These 5 bits determine the streams that will be used as the source data for the ST-BUS Analyzer buffer. 00: Dsti 01: DSTo 10: Csti 11: Csto
5	STBUFEN (0)	ST-BUS Analyser Buffer Enable. Setting this bit enables the ST-BUS Analyser Buffer update. When the user reads the buffer(920-93F), this bit must be 0. Any reads of the buffer while this bit is set does not ensure correct data being read.
4-2	FNUM (000)	Framer Number. 0 to 7.
1	CHUP (0)	Channel Update. If 0 the update of the memory is at frame rate for a given channel. The channel selected for update is provided by the ChanNum bits of this register. If set the complete frame(channels 0 to 32) are updated to the buffer.
0	CONTSIN (0)	Continuous Single. If set to 1 the ST-BUS Analyzer buffer is updated continuously. If set to zero the buffer is updated once and stopped. An optional interrupt can be generated once the buffer is full.

Table 200 - Global Control1 Register (R/W Address 901) (E1)

Bit	Name	Functional Description
15	F3HM (0)	Framer 3 HDLC Mask. This is the mask bit for the F3HVS status bit in the Interrupt Vector Register(address 910). If this mask bit is one, the corresponding Interrupt Vector status bit will remain inactive (zero). If this mask bit is zero, the corresponding Interrupt Vector status bit will function normally.
14	F3EM (0)	Framer 3 Elastic Mask. This is the mask bit for the F3EVS status bit in the Interrupt Vector Register (address 910). If this mask bit is one, the corresponding Interrupt Vector status bit will remain inactive (zero). If this mask bit is zero, the corresponding Interrupt Vector status bit will function normally.
13	F3RM (0)	Framer 3 Rx Line Mask. This is the mask bit for the F3RVS status bit in the Interrupt Vector Register (address 910). If this mask bit is one, the corresponding Interrupt Vector status bit will remain inactive (zero). If this mask bit is zero, the corresponding Interrupt Vector status bit will function normally.
12	F3SM (0)	Framer 3 Sync and Overflow Mask. This is the mask bit for the F3SVS status bit in the Interrupt Vector Register (address 910). If this mask bit is one, the corresponding Interrupt Vector status bit will remain inactive (zero). If this mask bit is zero, the corresponding Interrupt Vector status bit will function normally.
11	F2HM (0)	Framer 2 HDLC Mask. This is the mask bit for the F2HVS status bit in the Interrupt Vector Register (address 910). If this mask bit is one, the corresponding Interrupt Vector status bit will remain inactive (zero). If this mask bit is zero, the corresponding Interrupt Vector status bit will function normally.
10	F2EM (0)	Framer 2 Elastic Mask. This is the mask bit for the F2EVS status bit in the Interrupt Vector Register (address 910). If this mask bit is one, the corresponding Interrupt Vector status bit will remain inactive (zero). If this mask bit is zero, the corresponding Interrupt Vector status bit will function normally.
9	F2RM (0)	Framer 2 Rx Line Mask. This is the mask bit for the F2RVS status bit in the Interrupt Vector Register(address 910). If this mask bit is one, the corresponding Interrupt Vector status bit will remain inactive (zero). If this mask bit is zero, the corresponding Interrupt Vector status bit will function normally.
8	F2SM (0)	Framer 2 Sync and Overflow Mask. This is the mask bit for the F2SVS status bit in the Interrupt Vector Register (address 910). If this mask bit is one, the corresponding Interrupt Vector status bit will remain inactive (zero). If this mask bit is zero, the corresponding Interrupt Vector status bit will function normally.
7	F1HM (0)	Framer 1 HDLC Mask. This is the mask bit for the F1HVS status bit in the Interrupt Vector Register(address 910). If this mask bit is one, the corresponding Interrupt Vector status bit will remain inactive (zero). If this mask bit is zero, the corresponding Interrupt Vector status bit will function normally.
6	F1EM (0)	Framer 1 Elastic Mask. This is the mask bit for the F1EVS status bit in the Interrupt Vector Register(address 910). If this mask bit is one, the corresponding Interrupt Vector status bit will remain inactive (zero). If this mask bit is zero, the corresponding Interrupt Vector status bit will function normally.
5	F1RM (0)	Framer 1 Rx Line Mask. This is the mask bit for the F1RVS status bit in the Interrupt Vector Register(address 910). If this mask bit is one, the corresponding Interrupt Vector status bit will remain inactive (zero). If this mask bit is zero, the corresponding Interrupt Vector status bit will function normally.

Table 201 - Interrupt Vector 1 Mask Register (R/W Address 902) (E1)

Bit	Name	Functional Description
4	F1SM (0)	Framer 1 Sync and Overflow Mask. This is the mask bit for the F1SVS status bit in the Interrupt Vector Register (address 910). If this mask bit is one, the corresponding Interrupt Vector status bit will remain inactive (zero). If this mask bit is zero, the corresponding Interrupt Vector status bit will function normally.
3	F0HM (0)	Framer 0 HDLC Mask. This is the mask bit for the F0HVS status bit in the Interrupt Vector Register (address 910). If this mask bit is one, the corresponding Interrupt Vector status bit will remain inactive (zero). If this mask bit is zero, the corresponding Interrupt Vector status bit will function normally.
2	F0EM (0)	Framer 0 Elastic Mask. This is the mask bit for the F0EVS status bit in the Interrupt Vector Register (address 910). If this mask bit is one, the corresponding Interrupt Vector status bit will remain inactive (zero). If this mask bit is zero, the corresponding Interrupt Vector status bit will function normally.
1	F0RM (0)	Framer 0 Rx Line Mask. This is the mask bit for the F0RVS status bit in the Interrupt Vector Register (address 910). If this mask bit is one, the corresponding Interrupt Vector status bit will remain inactive (zero). If this mask bit is zero, the corresponding Interrupt Vector status bit will function normally.
0	F0SM (0)	Framer 0 Sync and Overflow Mask. This is the mask bit for the F0SVS status bit in the Interrupt Vector Register (address 910). If this mask bit is one, the corresponding Interrupt Vector status bit will remain inactive (zero). If this mask bit is zero, the corresponding Interrupt Vector status bit will function normally.

Table 201 - Interrupt Vector 1 Mask Register (R/W Address 902) (E1)

Bit	Name	Functional Description
15	F7HM (0)	Framer 7 HDLC Mask. This is the mask bit for the F7HVS status bit in the Interrupt Vector Register (address 910). If this mask bit is one, the corresponding Interrupt Vector status bit will remain inactive (zero). If this mask bit is zero, the corresponding Interrupt Vector status bit will function normally.
14	F7EM (0)	Framer 7 Elastic Mask. This is the mask bit for the F7EVS status bit in the Interrupt Vector Register (address 911). If this mask bit is one, the corresponding Interrupt Vector status bit will remain inactive (zero). If this mask bit is zero, the corresponding Interrupt Vector status bit will function normally.
13	F7RM (0)	Framer 7 Rx Line Mask. This is the mask bit for the F7RVS status bit in the Interrupt Vector Register (address 911). If this mask bit is one, the corresponding Interrupt Vector status bit will remain inactive (zero). If this mask bit is zero, the corresponding Interrupt Vector status bit will function normally.
12	F7SM (0)	Framer 7 Sync and Overflow Mask. This is the mask bit for the F7SVS status bit in the Interrupt Vector Register (address 911). If this mask bit is one, the corresponding Interrupt Vector status bit will remain inactive (zero). If this mask bit is zero, the corresponding Interrupt Vector status bit will function normally.
11	F6HM	Framer 6 HDLC Mask. This is the mask bit for the F6HVS status bit in the Interrupt Vector Register (address 910). If this mask bit is one, the corresponding Interrupt Vector status bit will remain inactive (zero). If this mask bit is zero, the corresponding Interrupt Vector status bit will function normally.

Table 202 - Interrupt Vector 2 Mask Register (R/W Address 903) (E1)

Bit	Name	Functional Description
10	F6EM (0)	Framer 6 Elastic Mask. This is the mask bit for the F6EVS status bit in the Interrupt Vector Register (address 911). If this mask bit is one, the corresponding Interrupt Vector status bit will remain inactive (zero). If this mask bit is zero, the corresponding Interrupt Vector status bit will function normally.
9	F6RM (0)	Framer 6 Rx LineMask. This is the mask bit for the F6RVS status bit in the Interrupt Vector Register (address 911). If this mask bit is one, the corresponding Interrupt Vector status bit will remain inactive (zero). If this mask bit is zero, the corresponding Interrupt Vector status bit will function normally.
8	F6SM (0)	Framer 6 Sync and Overflow Mask. This is the mask bit for the F6SVS status bit in the Interrupt Vector Register (address 911). If this mask bit is one, the corresponding Interrupt Vector status bit will remain inactive (zero). If this mask bit is zero, the corresponding Interrupt Vector status bit will function normally.
7	F5HM (0)	Framer 5 HDLC Mask. This is the mask bit for the F5HVS status bit in the Interrupt Vector Register (address 910). If this mask bit is one, the corresponding Interrupt Vector status bit will remain inactive (zero). If this mask bit is zero, the corresponding Interrupt Vector status bit will function normally.
6	F5EM (0)	Framer 5 Elastic Mask. This is the mask bit for the F5EVS status bit in the Interrupt Vector Register (address 911). If this mask bit is one, the corresponding Interrupt Vector status bit will remain inactive (zero). If this mask bit is zero, the corresponding Interrupt Vector status bit will function normally.
5	F5RM (0)	Framer 5 Rx Line Mask. This is the mask bit for the F5RVS status bit in the Interrupt Vector Register (address 911). If this mask bit is one, the corresponding Interrupt Vector status bit will remain inactive (zero). If this mask bit is zero, the corresponding Interrupt Vector status bit will function normally.
4	F5SM (0)	Framer 5 Sync and Overflow Mask. This is the mask bit for the F5SVS status bit in the Interrupt Vector Register (address 911). If this mask bit is one, the corresponding Interrupt Vector status bit will remain inactive (zero). If this mask bit is zero, the corresponding Interrupt Vector status bit will function normally.
3	F4HM (0)	Framer 4 HDLC Mask. This is the mask bit for the F4HVS status bit in the Interrupt Vector Register (address 910). If this mask bit is one, the corresponding Interrupt Vector status bit will remain inactive (zero). If this mask bit is zero, the corresponding Interrupt Vector status bit will function normally.
2	F4EM (0)	Framer 4 Elastic Mask. This is the mask bit for the F4EVS status bit in the Interrupt Vector Register (address 911). If this mask bit is one, the corresponding Interrupt Vector status bit will remain inactive (zero). If this mask bit is zero, the corresponding Interrupt Vector status bit will function normally.
1	F4RM (0)	Framer 4 Rx Line Mask. This is the mask bit for the F4RVS status bit in the Interrupt Vector register(address 911). If this mask bit is one, the corresponding Interrupt Vector status bit will remain inactive (zero). If this mask bit is zero, the corresponding Interrupt Vector status bit will function normally.
0	F4SM (0)	Framer 4 Sync and Overflow Mask. This is the mask bit for the F4SVS status bit in the Interrupt Vector Register (address 911). If this mask bit is one, the corresponding Interrupt Vector status bit will remain inactive (zero). If this mask bit is zero, the corresponding Interrupt Vector status bit will function normally.

Table 202 - Interrupt Vector 2 Mask Register (R/W Address 903) (E1)

Bit	Name	Functional Description
15	SLBK8 (0)	ST-BUS Loopback 8M All. If one, DSTo[0] is connected to DSTi[4], and DSTo[4] is connected to DSTi[0]. This can be used in 8.192 Mbit/s or 2.048 Mbit/s mode. See Loopbacks section.
14	SLBK67 (0)	ST-BUS Loopback Framer 6 & 7. If one, DSTo[6] is connected to DSTi[7], and DSTo[7] is connected to DSTi[6]. Used only in 2.048Mb/s mode. See Loopback section for details.
13	SLBK45 (0)	ST-BUS Loopback Framer 4 & 5. If one, DSTo[4] is connected to DSTi[5], and DSTo[5] is connected to DSTi[4]. Used only in 2.048Mb/s mode. See Loopbacks section.
12	SLBK23 (0)	ST-BUS Loopback Framer 2 & 3. If one, DSTo[2] is connected to DSTi[3], and DSTo[3] is connected to DSTi[2]. Used only in 2.048Mb/s mode. See Loopbacks section.
11	SLBK01 (0)	ST-BUS Loopback Framer 0 & 1. If one, DSTo[0] is connected to DSTi[1], and DSTo[1] is connected to DSTi[0]. Used only in 2.048Mb/s mode. See Loopbacks section.
10	RLBK8 (0)	Remote Loopback 8 Framers. If one, TPOS[0]/TNEG[0] are connected to RPOS[4]/RNEG[4], and TPOS[4]/TNEG[4] are connected to RPOS[0]/RNEG[0]. This is used especially for 8.192 Mbit/s mode but may also be used in 2.048Mb/s mode. See Loopbacks section.
9	RLBK67 (0)	Remote Loopback Framer 6 & 7. If one, TPOS[6]/TNEG[6] are connected to RPOS[7]/RNEG[7], and TPOS[7]/TNEG[7] are connected to RPOS[6]/RNEG[6]. Used only in 2.048Mb/s mode. See Loopbacks section.
8	RLBK45 (0)	Remote Loopback Framer 4 & 5. If one, TPOS[4]/TNEG[4] are connected to RPOS[5]/RNEG[5], and TPOS[5]/TNEG[5] are connected to RPOS[4]/RNEG[4]. Used only in 2.048Mb/s mode. See Loopbacks section.
7	RLBK23 (0)	Remote Loopback Framer 2 & 3. If one, TPOS[2]/TNEG[2] are connected to RPOS[3]/RNEG[3], and TPOS[3]/TNEG[3] are connected to RPOS[2]/RNEG[2]. Used only in 2.048Mb/s mode. See Loopbacks section.
6	RLBK01 (0)	Remote Loopback Framer 0 & 1. If one, TPOS[0]/TNEG[0] are connected to RPOS[1]/RNEG[1], and TPOS[1]/TNEG[1] are connected to RPOS[0]/RNEG[0]. Used only in 2.048Mb/s mode. See Loopbacks section.
5-0	(000000)	not used.

Table 203 - Framer Loopback Global Register(904) (E1)

Bit	Name	Functional Description
15-1	#	not used.
0	STM (0)	ST-BUS Analyser Mask. This is the mask bit for the F0STVS status bit in the ST-BUS Interrupt Vector Register (address 913). If this mask bit is one, the corresponding Interrupt Vector status bit will remain inactive (zero). If this mask bit is zero, the corresponding Interrupt Vector status bit will function normally.

Table 204 - Framer 0 ST-Bus Interrupt Vector Mask(905) (E1)

Bit	Name	Functional Description
15	F3HVS (0)	Framer 3 HDLC Vector Status. This bit if unmasked is set if any of the bits in the Interrupt HDLC register(333) for framer are set. This bit can be masked and will remain low by the F3HM bit in address 902.
14	F3EVS (0)	Framer 3 Elastic Vector Status. This bit if unmasked is set if any of the bits in the Interrupt Receive Elastic store register(336) or Elastic store status for Framer 3 are set. This bit can be masked and will remain low by the F3EM bit in address 902.
13	F3RVS (0)	Framer 3 Rx Line Vector Status. This bit if unmasked is set if any of the bits in the Interrupt Receive Line status register(335) for Framer 0 are set. This bit can be masked and will remain low by the F3RM bit in address 902.
12	F3SVS (0)	Framer 3 Sync Vector Status. This bit if unmasked is set if any of the bits in the Interrupt Sync status register(334) for Framer 3 are set. This bit can be masked and will remain low by the F3SM bit in address 902.
11	F2HVS (0)	Framer 2 HDLC Vector Status. This bit if unmasked is set if any of the bits in the Interrupt HDLC register(233) or Elastic store status far Framer 2 are set. This bit can be masked and will remain low by the F2HM bit in address 902.
10	F2EVS (0)	Framer 2 Elastic Vector Status. This bit if unmasked is set if any of the bits in the Interrupt Receive Elastic status register(236) or Elastic store status for Framer 2 are set. This bit can be masked and will remain low by the F2EM bit in address 902.
9	F2RVS (0)	Framer 2 Rx Line Vector Status. This bit if unmasked is set if any of the bits in the Interrupt Receive Line status register(235) for Framer 2 are set. This bit can be masked and will remain low by the F2RM bit in address 902.
8	F2SVS (0)	Framer 2 Sync Vector Status. This bit if unmasked is set if any of the bits in the Interrupt Counter status register(234) for Framer 2 are set. This bit can be masked and will remain low by the F2SM bit in address 902.
7	F1HVS (0)	Framer 1 HDLC Vector Status. This bit if unmasked is set if any of the bits in the Interrupt HDLC register(133) or Elastic store status for Framer 1 are set. This bit can be masked and will remain low by the F2HM bit in address 902.
6	F1EVS (0)	Framer 1 Elastic Vector Status. This bit if unmasked is set if any of the bits in the Interrupt Receive Elastic store register(136) or Elastic store status for Framer 1 are set. This bit can be masked and will remain low by the F1EM bit in address 902.
5	F1RVS (0)	Framer 1 Rx Line Vector Status. This bit if unmasked is set if any of the bits in the Interrupt Receive Line status register(135) for Framer 1 are set. This bit can be masked and will remain low by the F1RM bit in address 902.
4	F1SVS (0)	Framer 1 Sync Vector Status. This bit if unmasked is set if any of the bits in the Interrupt Sync status register(134) for Framer 3 are set. This bit can be masked and will remain low by the F1SM bit in address 902.
3	F0HVS (0)	Framer 0 HDLC Vector Status. This bit if unmasked is set if any of the bits in the Interrupt HDLC register(033) or Elastic store status for Framer 0 are set. This bit can be masked and will remain low by the F0HM bit in address 902.
2	F0EVS (0)	Framer 0 Elastic Vector Status. This bit if unmasked is set if any of the bits in the Interrupt Receive Elastic store register(036) or Elastic store status for Framer 0 are set. This bit can be masked and will remain low by the F0EM bit in address 902.
1	F0RVS (0)	Framer 0 Rx Line Vector Status. This bit if unmasked is set if any of the bits in the Interrupt Receive Line status register(035) for Framer 0 are set. This bit can be masked and will remain low by the F0RM bit in address 902.

Table 205 - Interrupt Vector 1 Status Register (R/W Address 910) (E1)

Bit	Name	Functional Description
0	F0SVS (0)	Framer 0 Sync Vector Status. This bit if unmasked is set if any of the bits in the Interrupt Sync status register(034) for Framer 0 are set. This bit can be masked and will remain low by the F0SM bit in address 902.

Table 205 - Interrupt Vector 1 Status Register (R/W Address 910) (E1)

Bit	Name	Functional Description
15	F7HVS (0)	Framer 3 HDLC Vector Status. This bit if unmasked is set if any of the bits in the Interrupt HDLC register(733) for Framer 7 are set. This bit can be masked and will remain low by the F7HM bit in address 903.
14	F7EVS (0)	Framer 7 Elastic Vector Status. This bit if unmasked is set if any of the bits in the Interrupt HDLC register(736) or Elastic store status for Framer 7 are set. This bit can be masked and will remain low by the F7EM bit in address 903.
13	F7RVS (0)	Framer 7 Rx Line Vector Status. This bit if unmasked is set if any of the bits in the Interrupt HDLC register(735) for Framer 7 are set. This bit can be masked and will remain low by the F7RM bit in address 903 .
12	F7SVS (0)	Framer 7 Sync Vector Status. This bit if unmasked is set if any of the bits in the Interrupt HDLC register(734) for Framer 3 are set. This bit can be masked and will remain low by the F7SM bit in address 903.
11	F6HVS (0)	Framer 6 HDLC Vector Status. This bit if unmasked is set if any of the bits in the Interrupt HDLC register(663) or Elastic store status for Framer 6 are set. This bit can be masked and will remain low by the F7HM bit in address 903.
10	F6EVS (0)	Framer 6 Elastic Vector Status. This bit if unmasked is set if any of the bits in the Interrupt Receive Elastic store register(636) or Elastic store status for Framer 5 are set. This bit can be masked and will remain low by the F5EM bit in address 903.
9	F6RVS (0)	Framer 6 Rx Line Vector Status. This bit if unmasked is set if any of the bits in the Interrupt Receive Line status register(635) for Framer 6 are set. This bit can be masked and will remain low by the F6RM bit in address 903.
8	F6SVS (0)	Framer 6 Sync Vector Status. This bit if unmasked is set if any of the bits in the Interrupt Counter status register(634) for Framer 6 are set. This bit can be masked and will remain low by the F6SM bit in address 903.
7	F5HVS (0)	Framer 3 HDLC Vector Status. This bit if unmasked is set if any of the bits in the Interrupt HDLC register(533) or Elastic store status for Framer 5 are set. This bit can be masked and will remain low by the F7HM bit in address 903.
6	F5EVS (0)	Framer 5 Elastic Vector Status. This bit if unmasked is set if any of the bits in the Interrupt Receive Elastic store register(536) or Elastic store status for Framer 5 are set. This bit can be masked and will remain low by the F5EM bit in address 903.
5	F5RVS (0)	Framer 5 Rx Line Vector Status. This bit if unmasked is set if any of the bits in the Interrupt Receive Line status register(535) are Framer 5 are set. This bit can be masked and will remain low by the F1RM bit in address 903.
4	F5SVS (0)	Framer 5 Sync Vector Status. This bit if unmasked is set if any of the bits in the Interrupt Sync status register(534) for Framer 5 are set. This bit can be masked and will remain low by the F1SM bit in address 903.

Table 206 - Interrupt Vector 2 Status Register (Address 911) (E1)

Bit	Name	Functional Description
3	F4HVS (0)	Framer 4 HDLC Vector Status. This bit if unmasked is set if any of the bits in the HDLC status register(433)status for Framer 4 are set. This bit can be masked and will remain low by the F7HM bit in address 903.
2	F4EVS (0)	Framer 4 Elastic Vector Status. This bit if unmasked is set if any of the bits in the Interrupt Receive Elastic store register(436) or Elastic store status for Framer 4 are set. This bit can be masked and will remain low by the F4EM bit in address 903.
1	F4RVS (0)	Framer 4 Rx Line Vector Status. This bit if unmasked is set if any of the bits in the Interrupt Receive Line status register(435) for Framer 4 are set. This bit can be masked and will remain low by the F4RM bit in address 903.
0	F4SVS (0)	Framer 4 Sync Vector Status. This bit if unmasked is set if any of the bits in the Interrupt Sync status register(434) Framer 4 are set. This bit can be masked and will remain low by the F4SM bit in address 903.

Table 206 - Interrupt Vector 2 Status Register (Address 911) (E1)

Bit	Name	Functional Description
15-3	ID15-3	ID Number. Contains 0100000001011.
2 1 0	ID2-0 (000)	These 3 bits make up a binary code which identify the revision of this deviceID Number.

Table 207 - Identification Revision Code Data Register (R Address 912) (E1)

Bit	Name	Functional Description
15-1	#	not used.
0	STIS (0)	ST-BUS Analyser Interrupt Status. This bit (if unmasked) is set if the ST-BUS Analyser is filled up. This bit can be masked and will remain low by the FSTM bit in address 905.

Table 208 - ST-Bus Analyser Vector Status Register (Address 913) (E1)

Bit	Name	Functional Description
15-8	#	not used.
7-0	STAD (7-0) (0)	ST-BUS Analyser Data. This is the data for the ST-BUS analyser buffer. 920 is the first byte of the data that is being "analyzed". The source of the data can be any ST-BUS stream from any Framer.

Table 209 - ST-BUS Analyser Data (Address 920-93F) (E1)

15.0 Applications

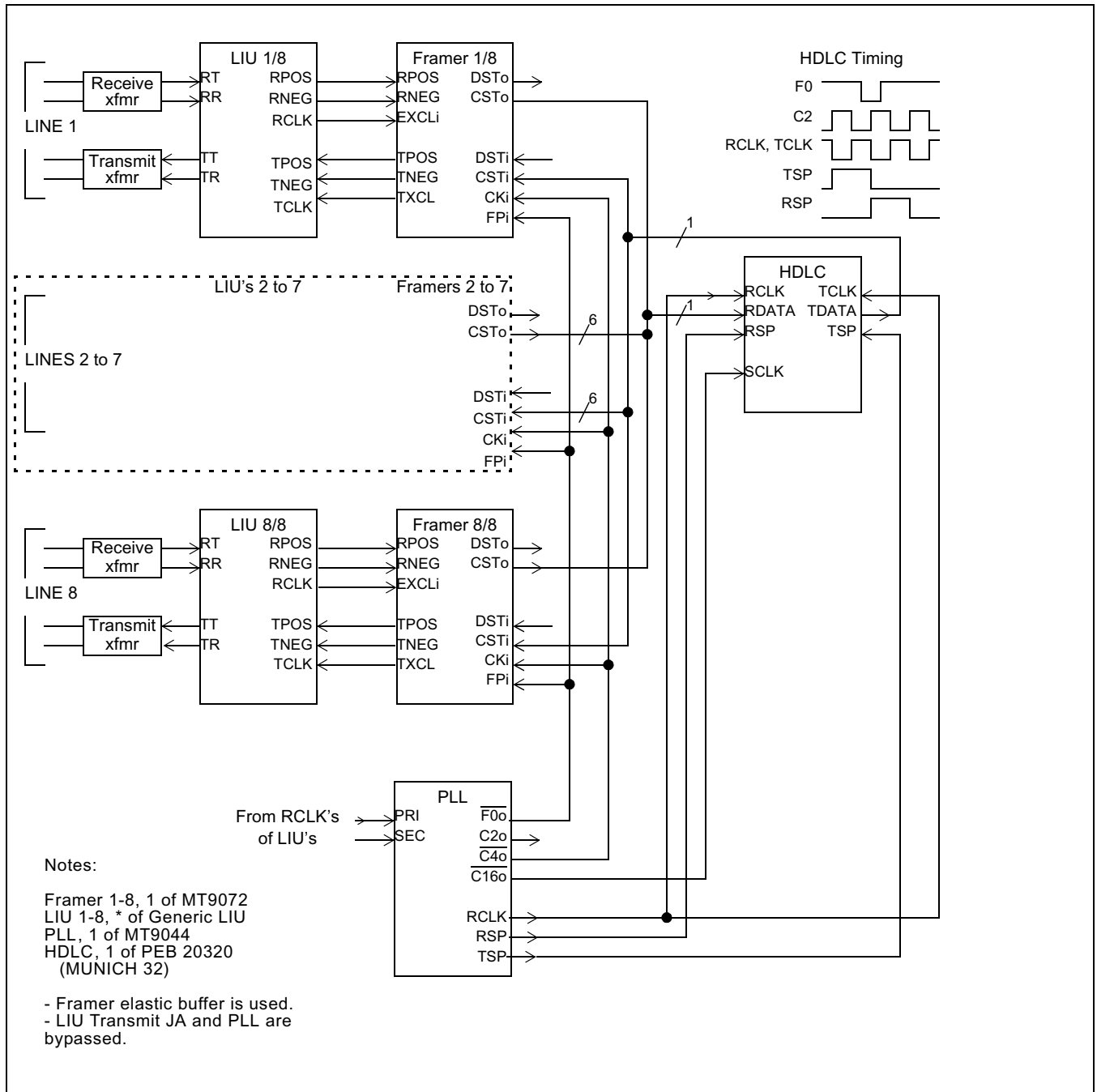

Figure 8 - 8 T1 Links with Synchronous Common Channel Signaling for up to 24 Channels

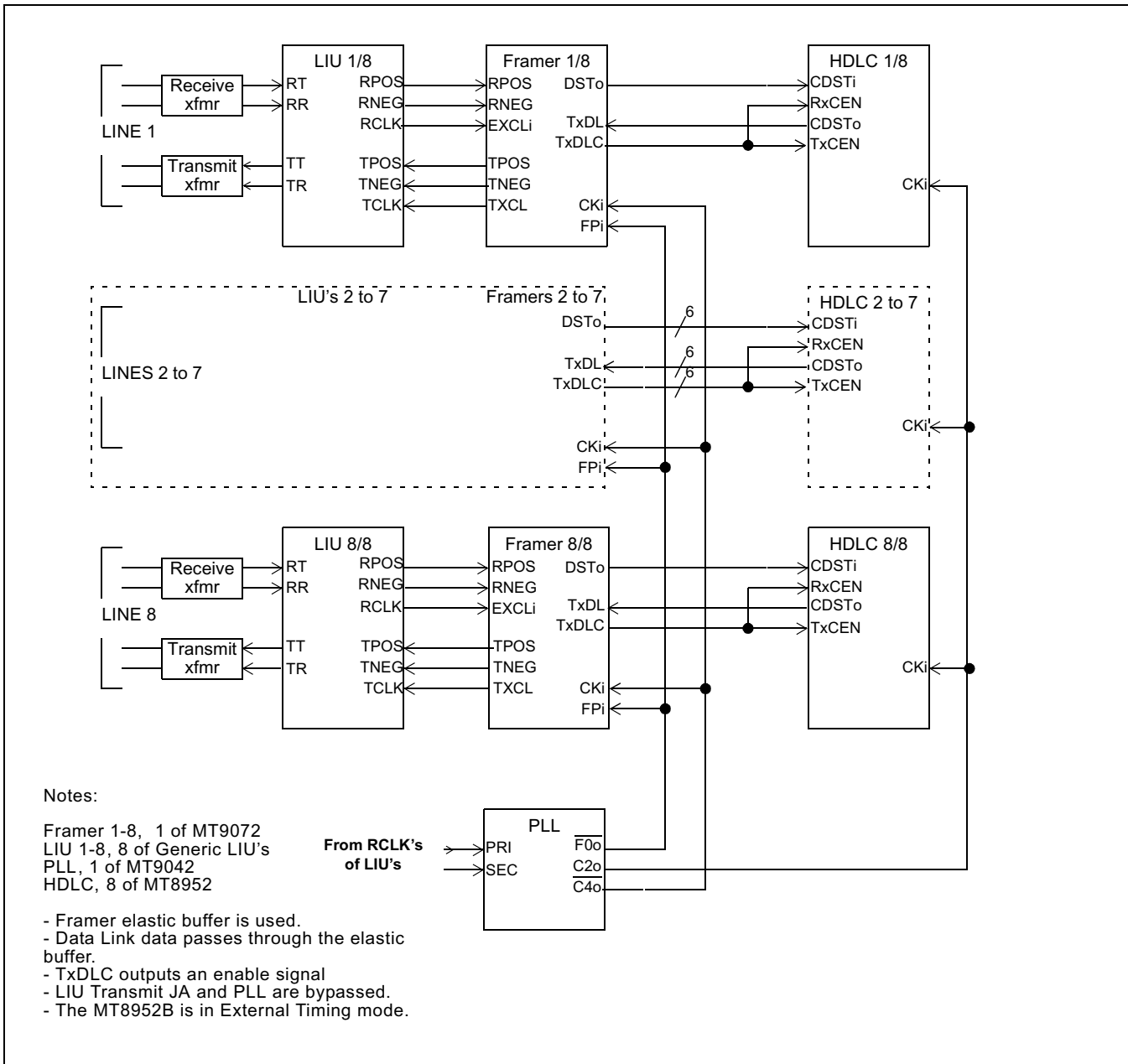

Figure 9 - 8 T1 Links with Synchronous Data Link Signaling

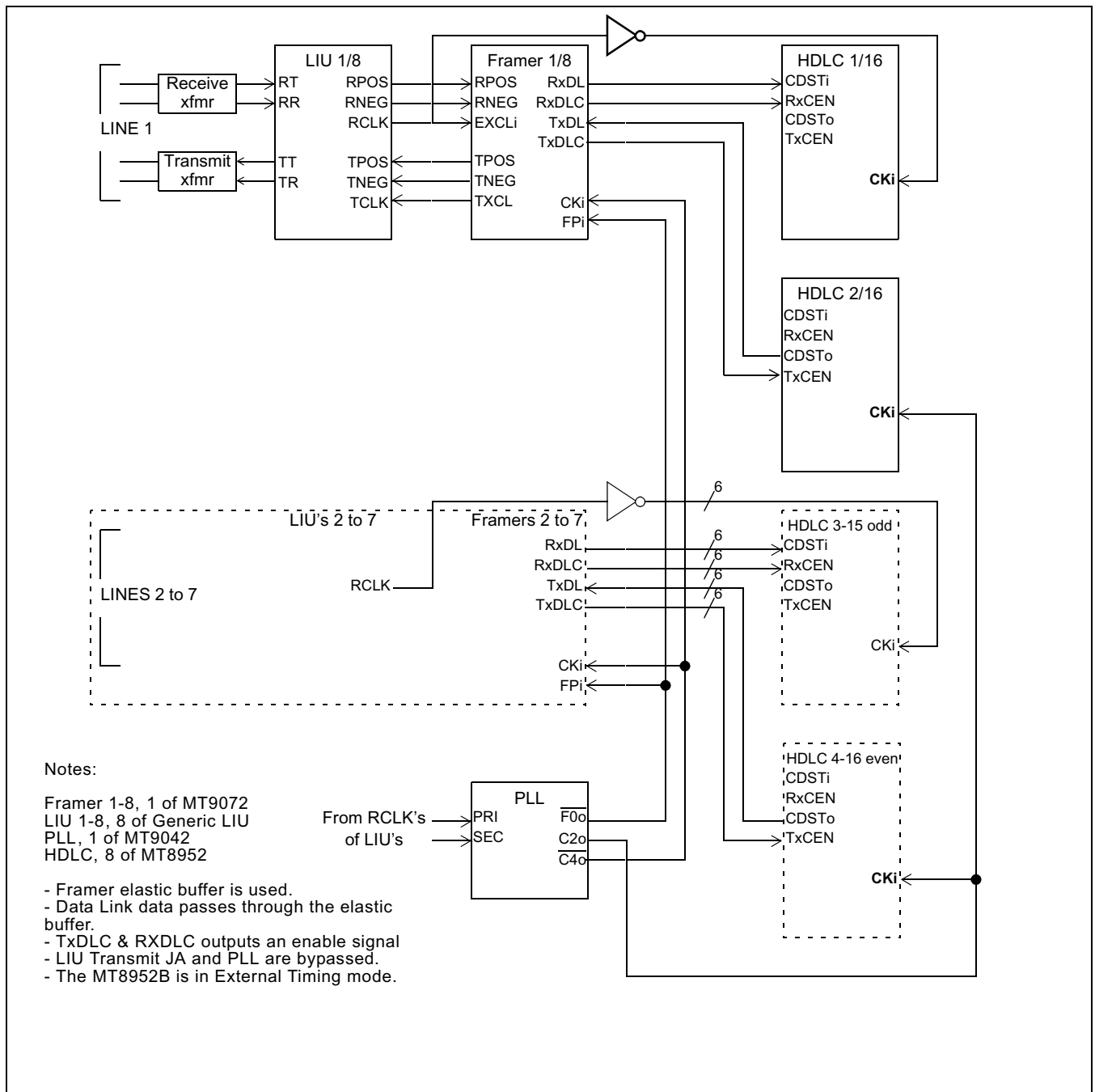

Figure 10 - 8 T1 Links with Asynchronous Data Link Signaling

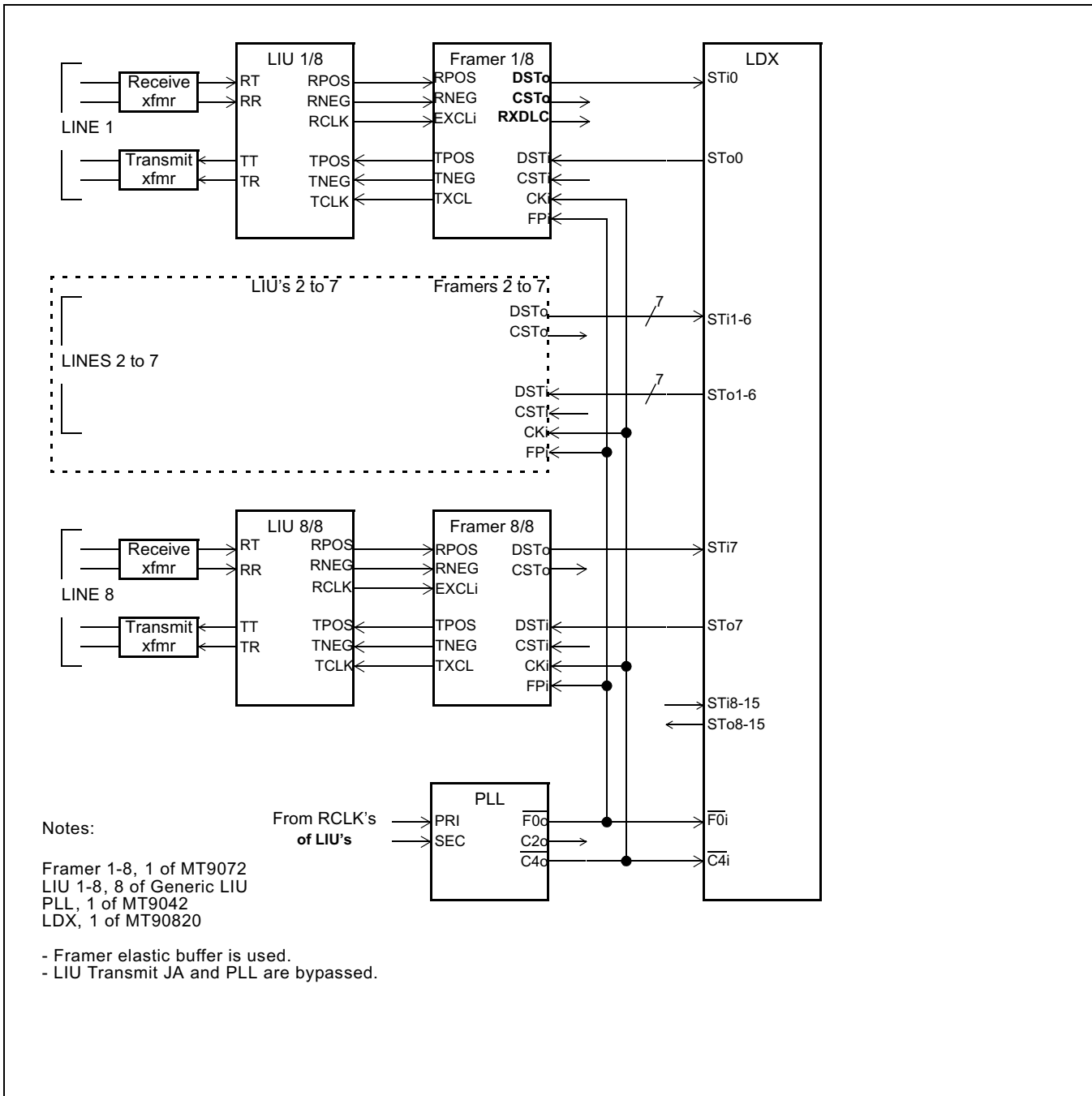

Figure 11 - 8 T1 Links with no JA or PLL in LIU, Slave or Master Mode, Jitter-Free ST-BUS

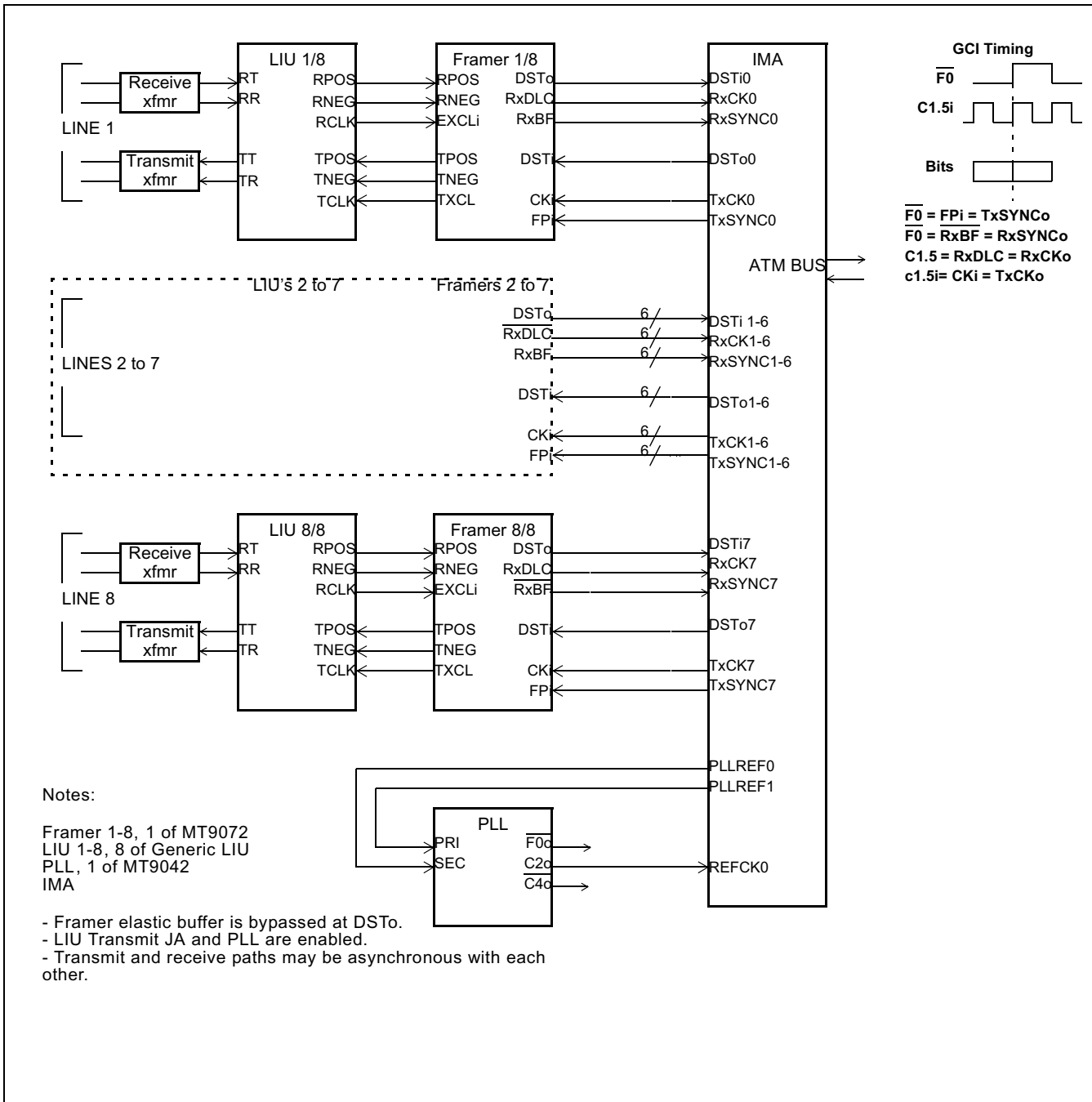
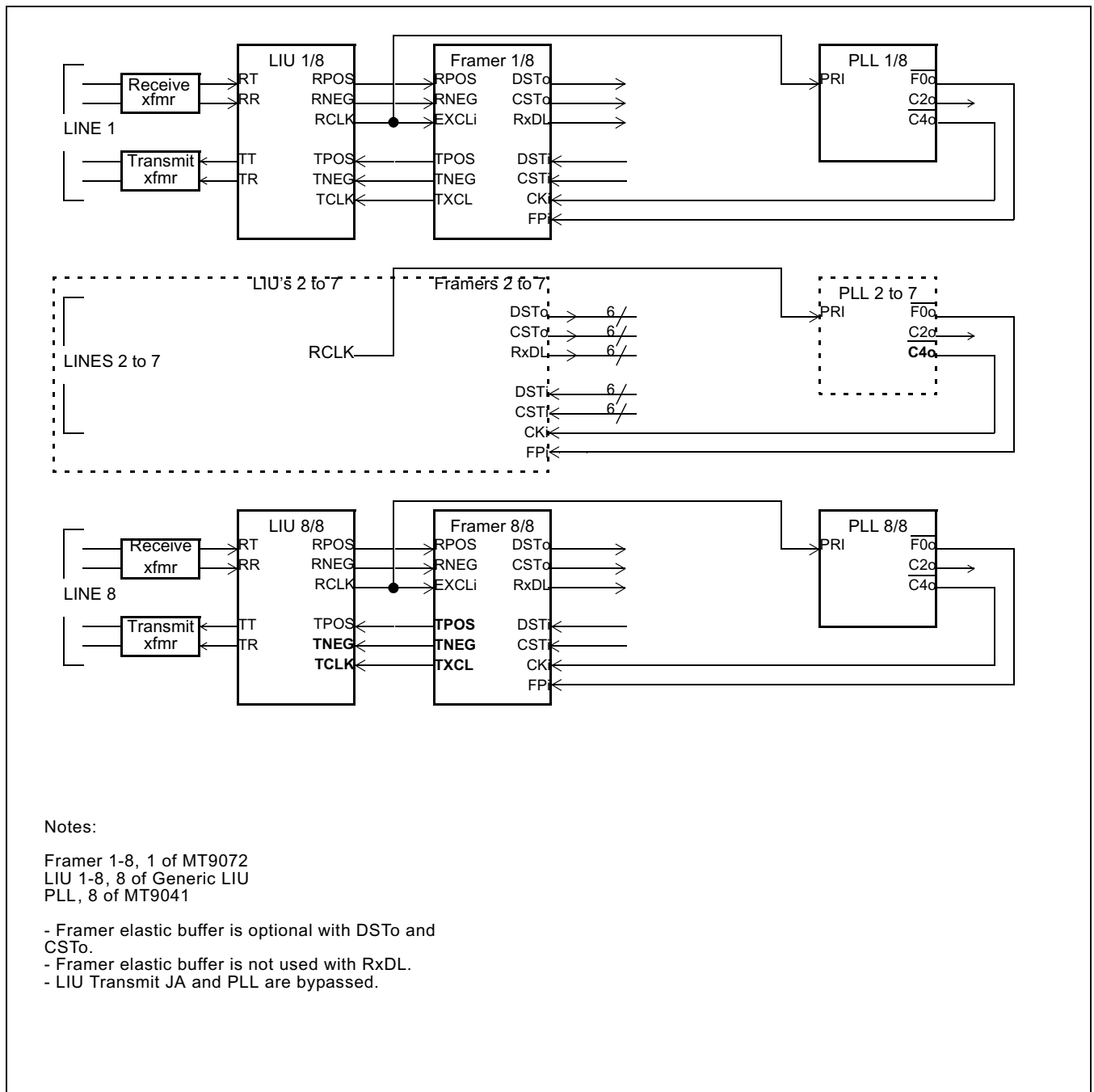

Figure 13 - 8 E1 Links with ATM IMA with Asynchronous ST-BUS Mode



Notes:

Framer 1-8, 1 of MT9072
 LIU 1-8, 8 of Generic LIU
 PLL, 8 of MT9041

- Framer elastic buffer is optional with DSTo and CSTo.
- Framer elastic buffer is not used with RxDL.
- LIU Transmit JA and PLL are bypassed.

Figure 14 - 8 T1 Links with Asynchronous ST-BUS

E1 Mode

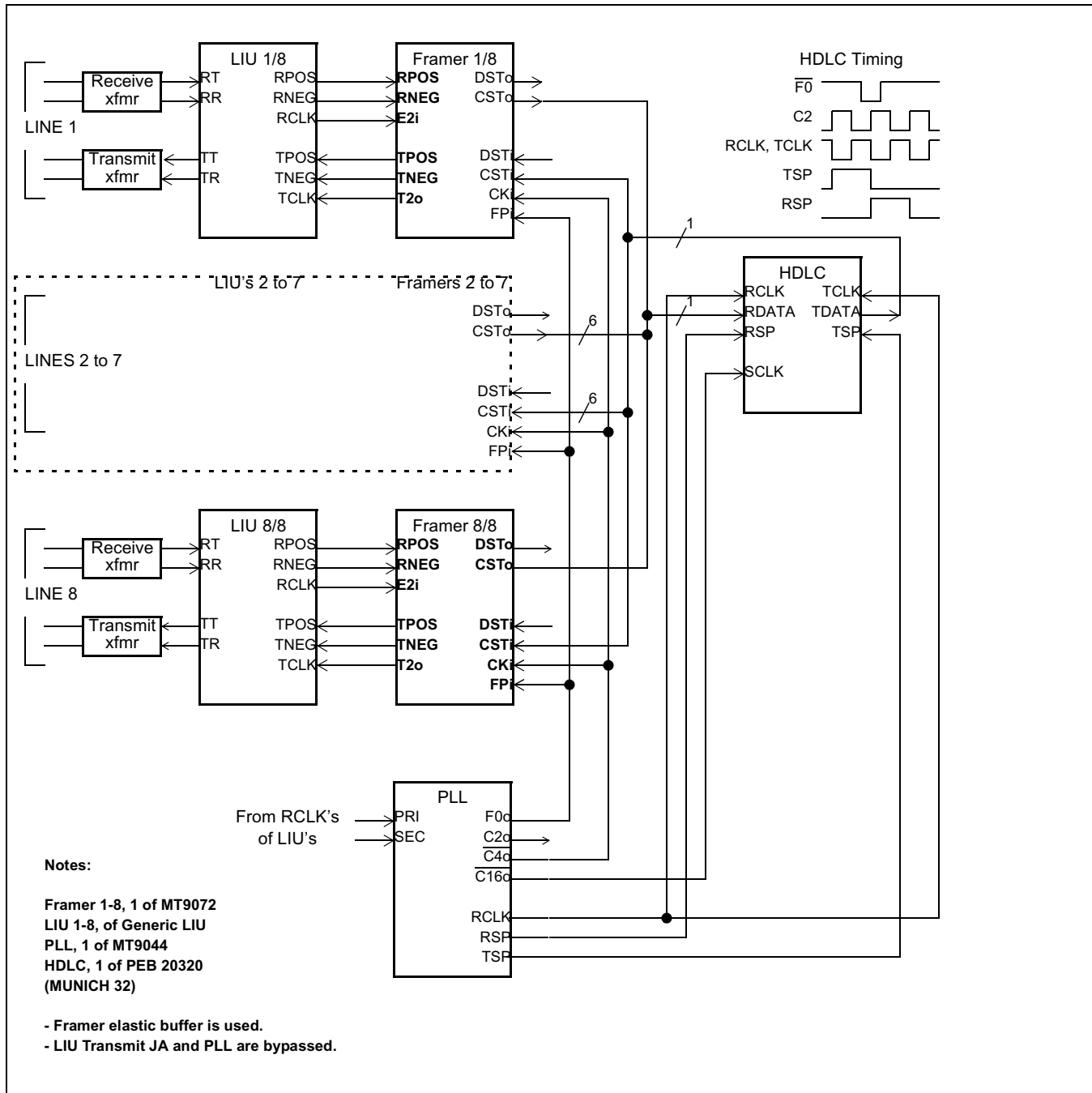

Figure 15 - 8 E1 Links with Synchronous Common Channel Signaling for up to 24 Channels

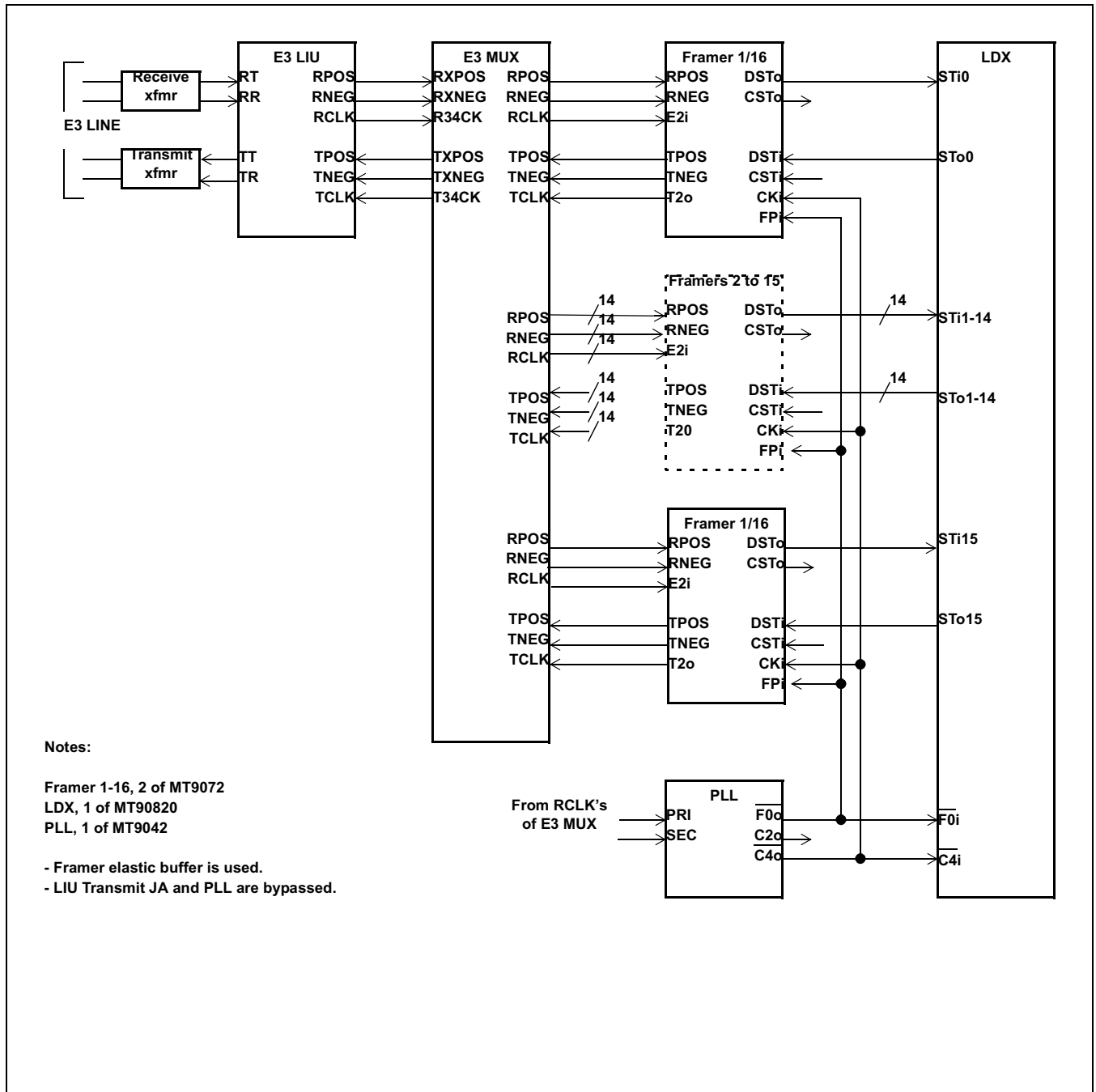
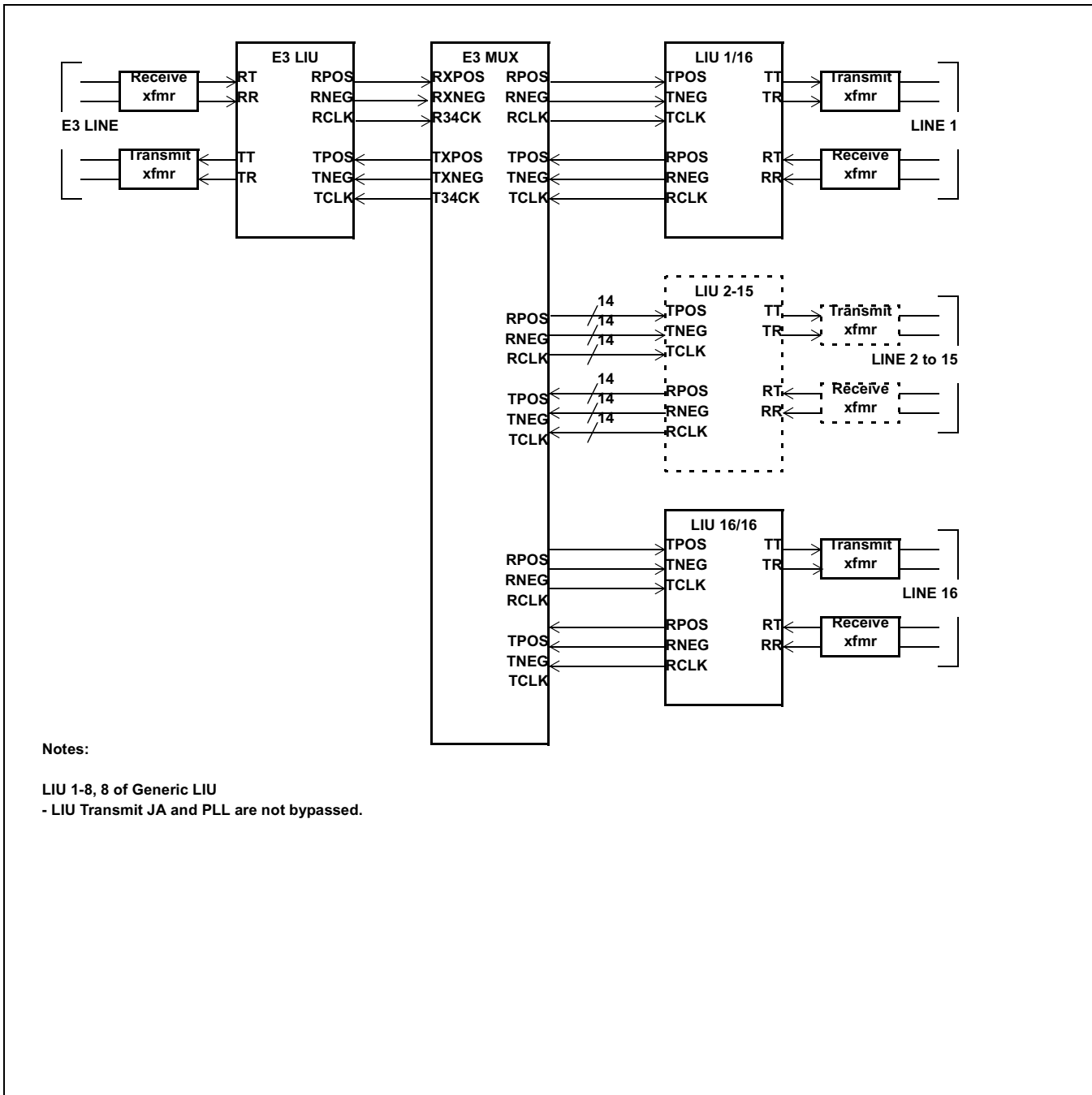

Figure 16 - E3 (34Mb/s) MUX Cross Connect with 16 Asynchronous E1 Links



Notes:

- LIU 1-8, 8 of Generic LIU
- LIU Transmit JA and PLL are not bypassed.

Figure 17 - E3 (34Mb/s) MUX Concentrator to 16 Asynchronous E1 Links

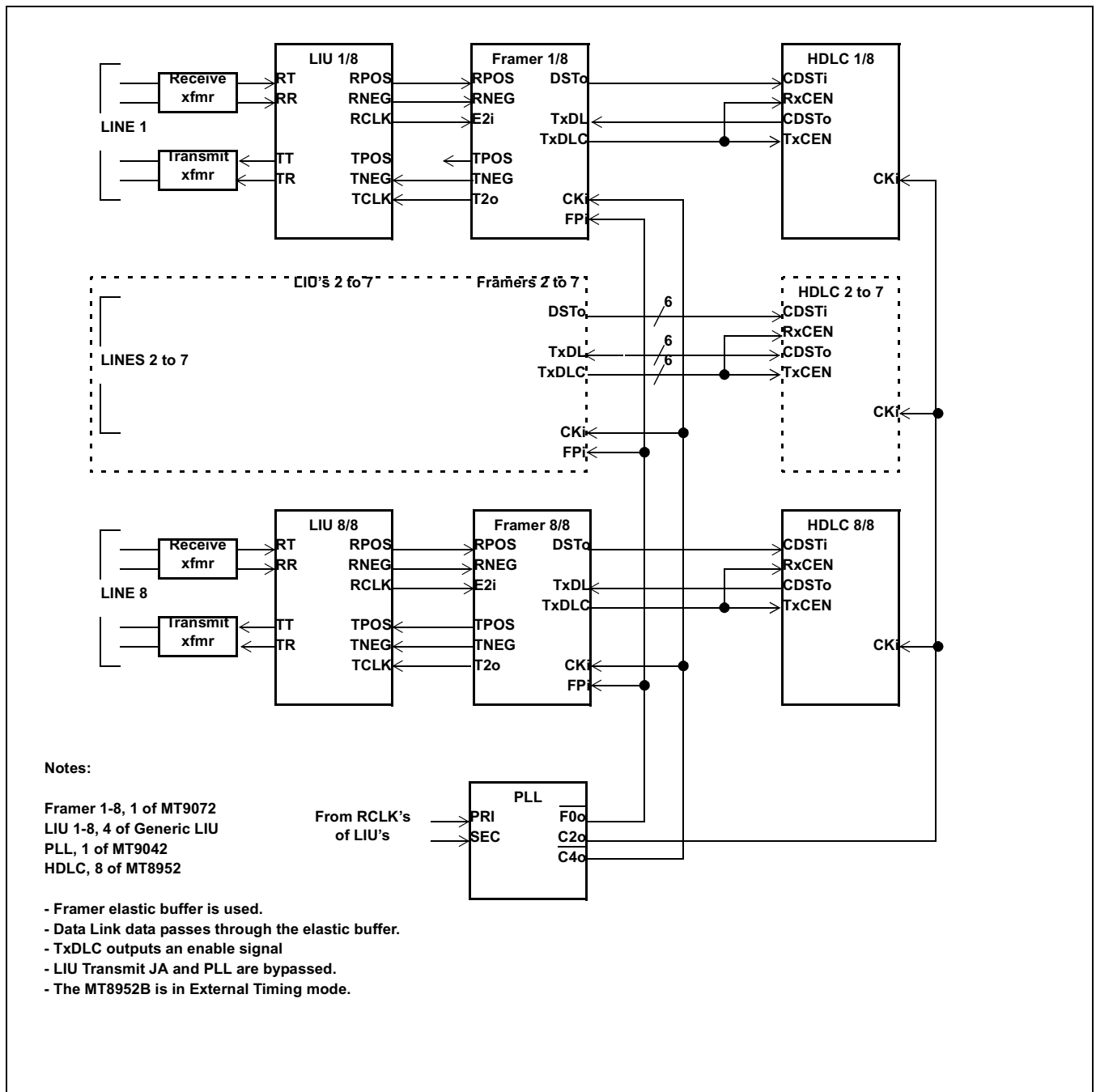

Figure 18 - 8 E1 Links with Synchronous Data Link signaling

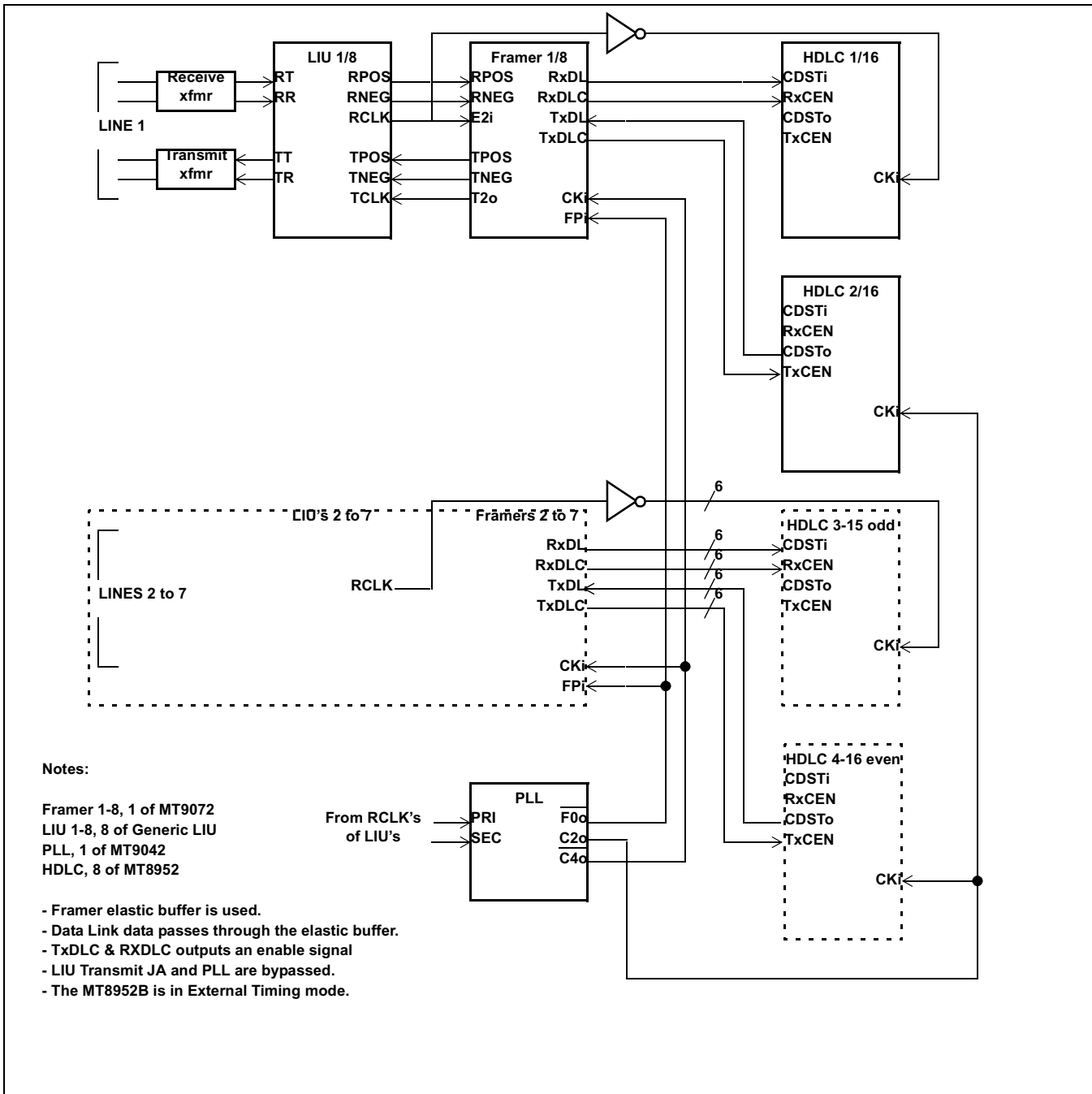

Figure 19 - 8 E1 Links with Asynchronous Data Link Signaling

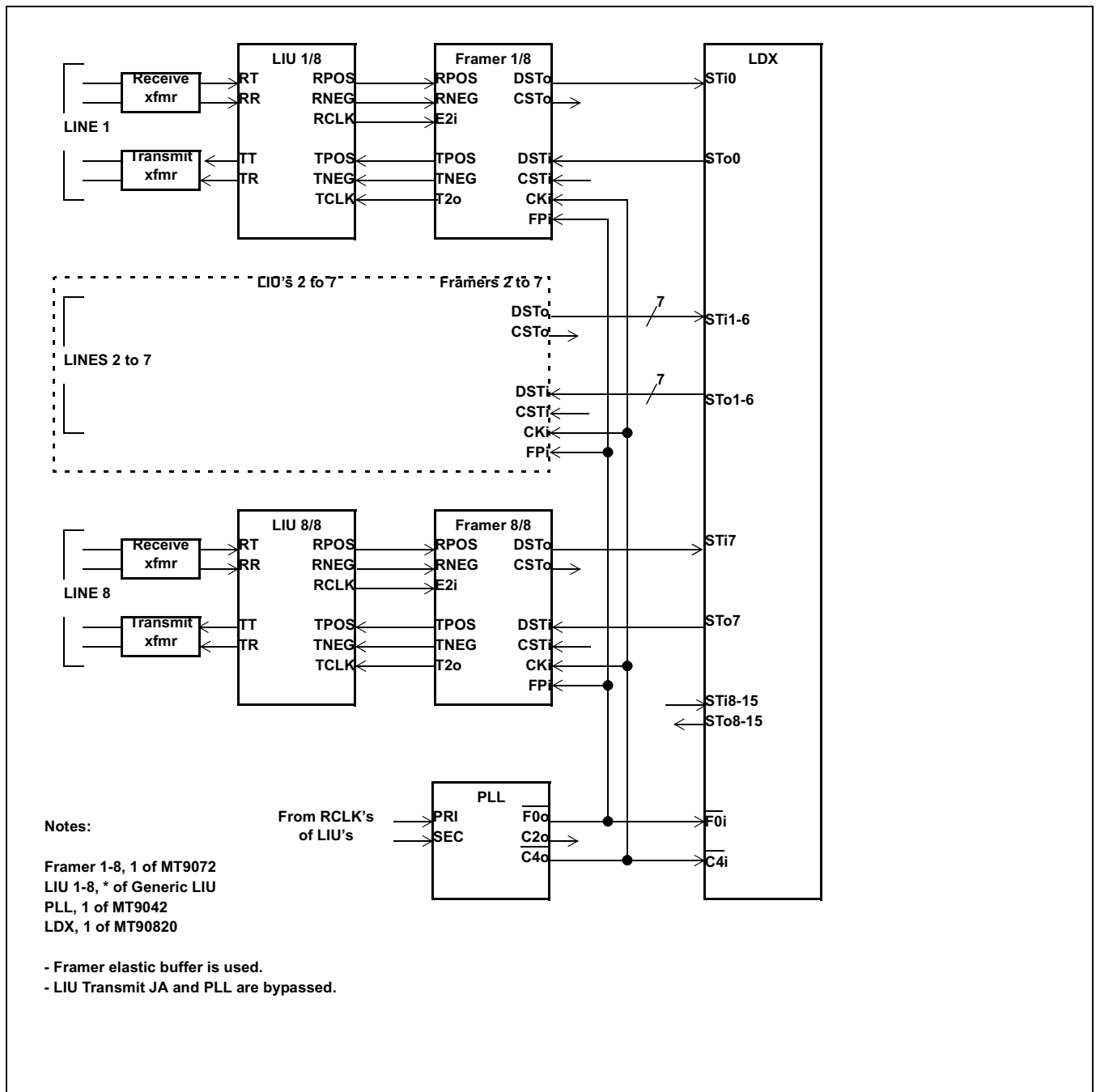

Figure 20 - 8 E1 Links with no JA or PLL in LIU, Slave or Master Mode, Jitter-Free ST-BUS

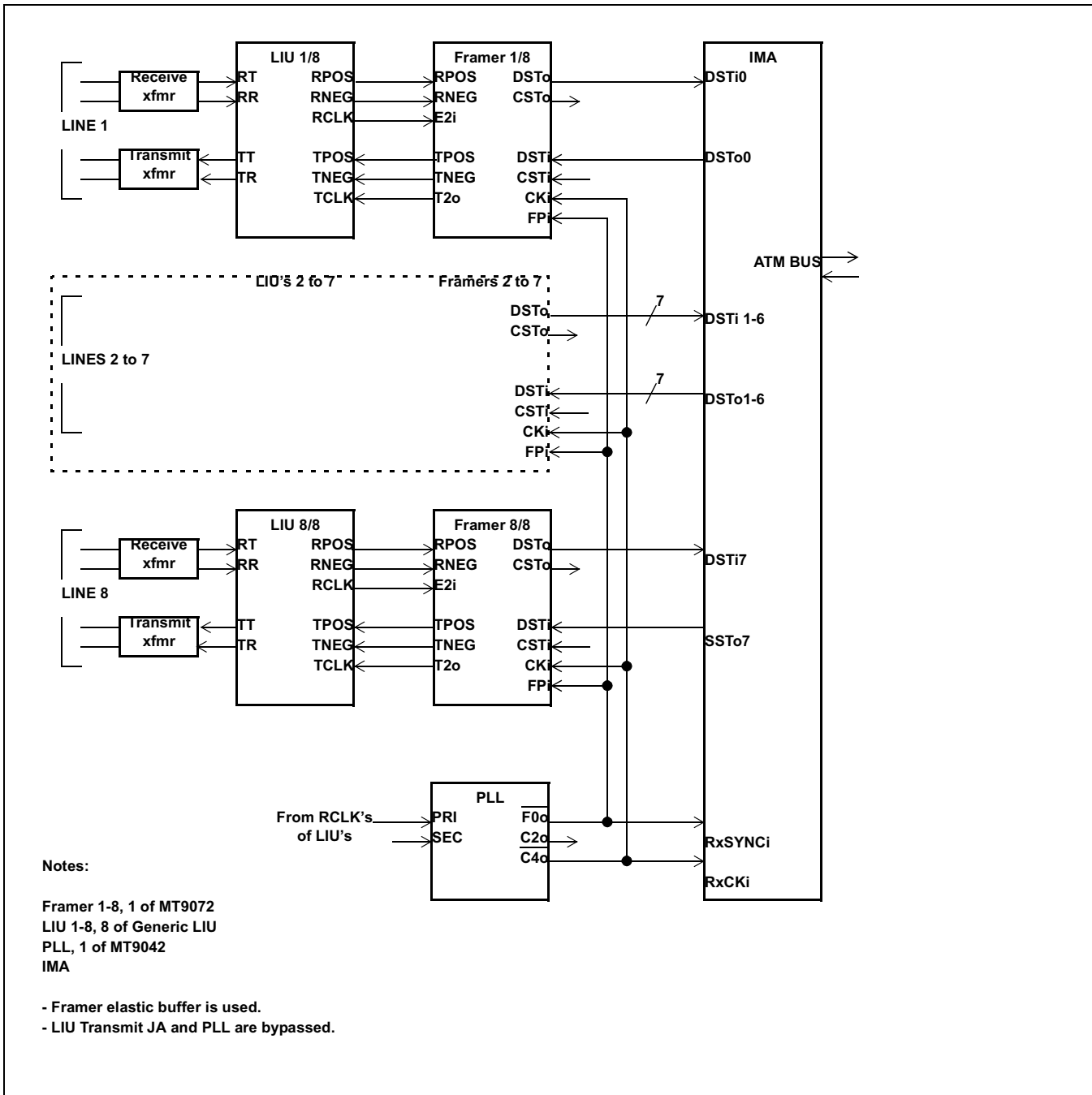

Figure 21 - 8 E1 Links with ATM IMA with Synchronous ST-BUS Mode

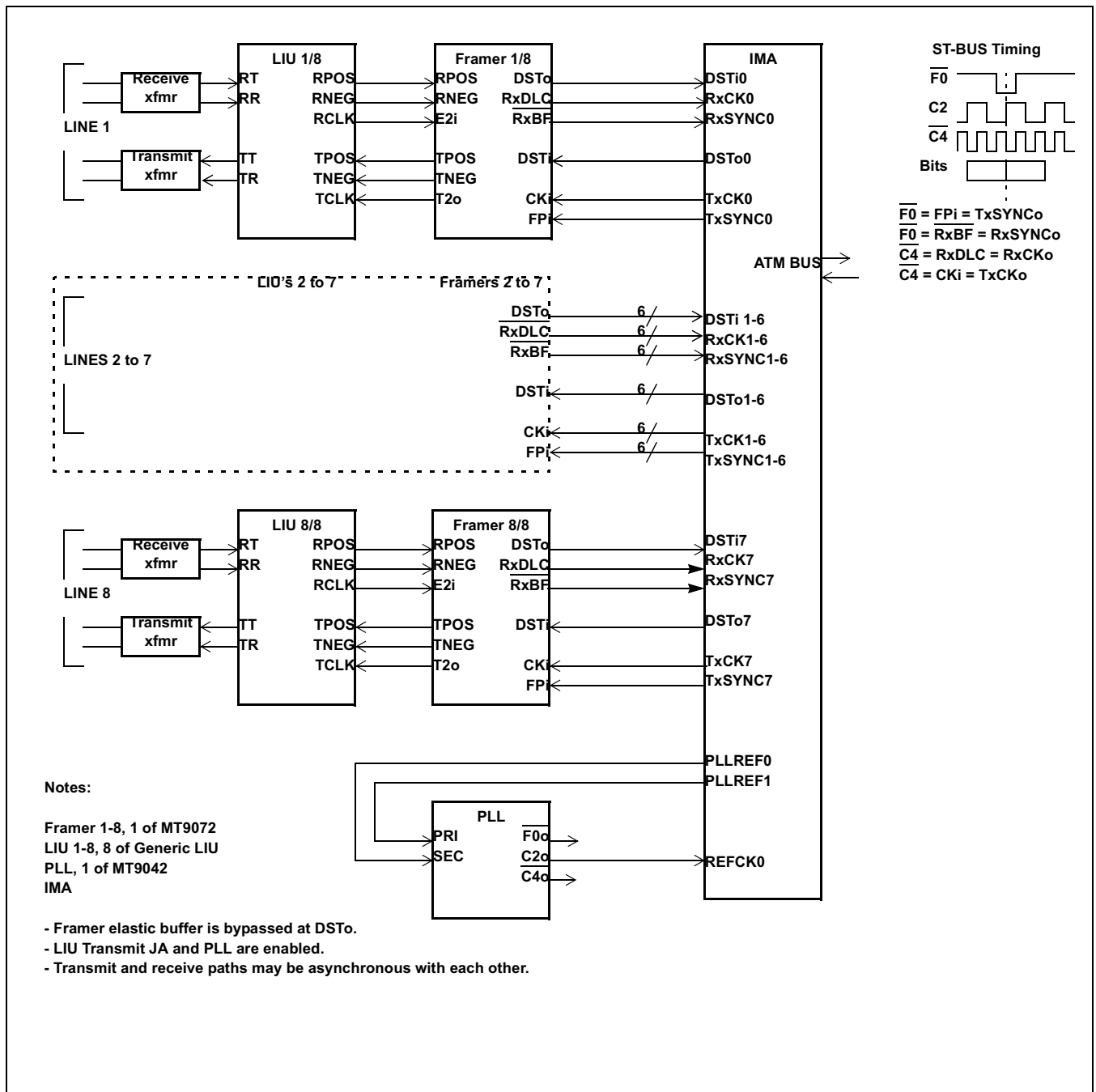
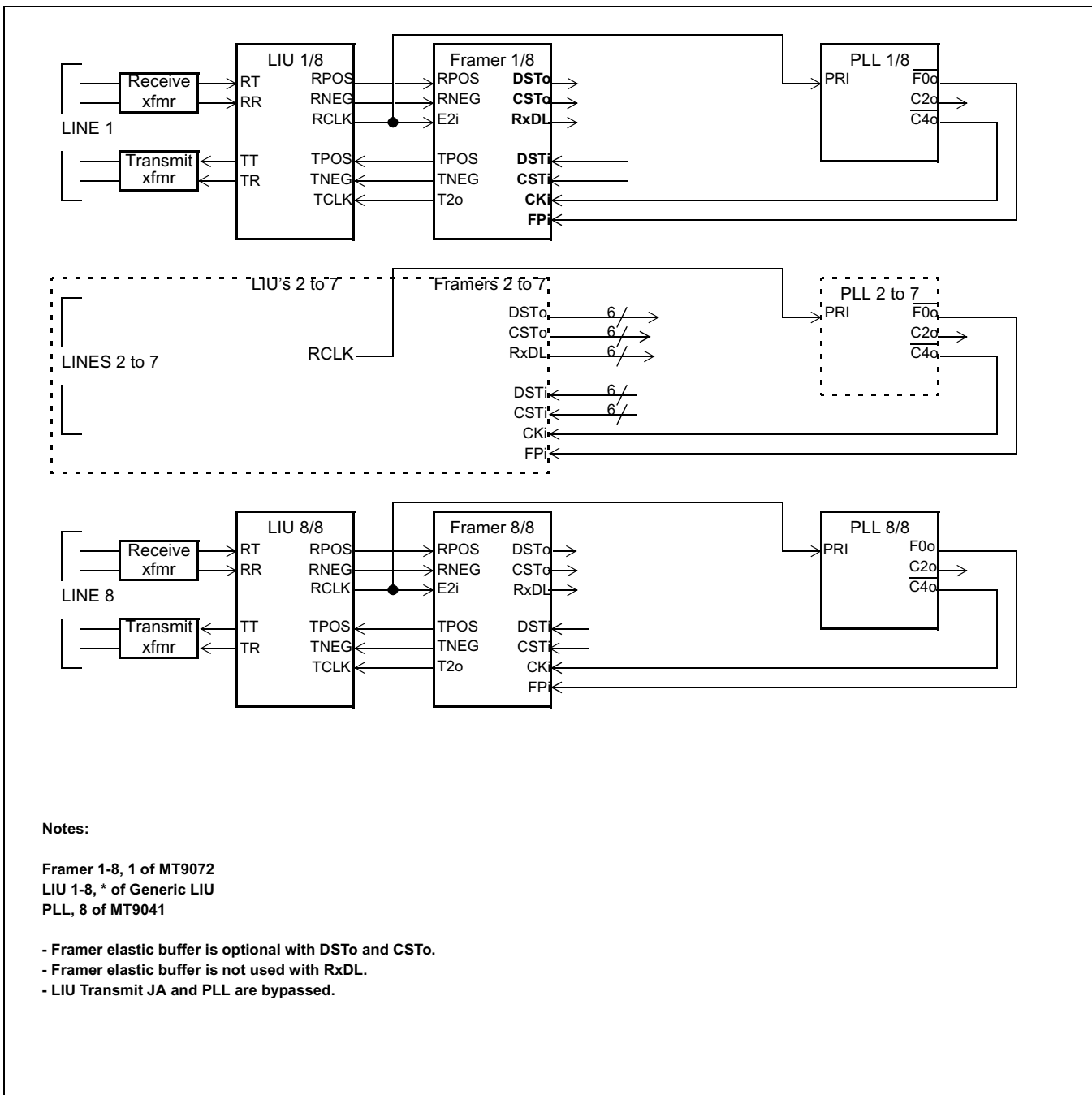

Figure 22 - 8 E1 Links with ATM IMA with Asynchronous ST-BUS Mode



Notes:

Framer 1-8, 1 of MT9072
 LIU 1-8, * of Generic LIU
 PLL, 8 of MT9041

- Framer elastic buffer is optional with DSTo and CSTo.
- Framer elastic buffer is not used with RxDL.
- LIU Transmit JA and PLL are bypassed.

Figure 23 - 8 E1 Links with Asynchronous ST-BUS

16.0 AC/DC Electrical Characteristics

16.1 T1 Mode

Absolute Maximum Ratings* - Voltages are with respect to ground (VSS) unless otherwise stated.

	Parameter	Symbol	Min	Max	Units
1	Supply Voltage	V_{DD}	-0.5	5.0	V
2	Voltage at Digital Inputs	V_I	-0.5	$V_{DD} + 0.5$	V
3	Current at Digital Inputs	I_I		30	mA
4	Voltage at Digital Outputs	V_O	-0.5	$V_{DD} + 0.5$	V
5	Current at Digital Outputs	I_O		30	mA
6	Storage Temperature	T_{ST}	-55	150	°C

* Exceeding these values may cause permanent damage. Functional operation under these conditions is not implied.

Recommended Operating Conditions* - Voltages are with respect to ground (VSS) unless otherwise stated

	Characteristics	Sym	Min	Typ	Max	Units	Test Conditions
1	Operating Temperature	T_{OP}	-40	25	85	°C	
2	Supply Voltage	V_{DD}	2.7	3.3	3.6	V	

DC Electrical Characteristics† - Voltages are with respect to ground (VSS) unless otherwise stated

	Characteristics	Sym	Min	Typ‡	Max	Units	Test Conditions
1	Supply Current	I_{DD}		30		mA	Outputs unloaded. Transmitting an all 1's signal.
2	Input High Voltage (Digital Inputs)	V_{IH}	2.0		V_{DD}	V	
3	Input Low Voltage (Digital Inputs)	V_{IL}	0		0.8	V	
4	Input Leakage (Digital Inputs)	I_{IL}		1	10	μA	$V_I = 0$ to V_{DD}
5	Output High Voltage (Digital Outputs)	V_{OH}	2.4		V_{DD}	V	$I_{OH}=7$ mA @ $V_{OH}=2.4$ V
6	Output High Current (Digital Outputs)	I_{OH}		7		mA	Source $V_{OH}=2.4$ V
7	Output Low Voltage (Digital Outputs)	V_{OL}	V_{SS}		0.4	V	$I_{OL}=2$ mA @ $V_{OL}=0.4$ V
8	Output Low Current (Digital Outputs)	I_{OL}		2		mA	Sink $V_{OL}=0.4$ V
9	High Impedance Leakage (Digital I/O)	I_{OZ}		1	10	μA	$V_O = 0$ to V_{DD}

† Characteristics are for clocked operation over the ranges of recommended operating temperature and supply voltage.

‡ Typical figures are at 25°C and are for design aid only: not guaranteed and not subject to production testing.

AC Electrical Characteristics - Timing Parameter Measurement Voltage Levels* - Voltages are with respect to ground (VSS) unless otherwise stated.

	Characteristics	Sym	Level	Units	Conditions/Notes
1	Threshold Voltage	V_T	1.5 $0.5 * V_{DD}$	V V	TTL CMOS
2	Rise/Fall Threshold Voltage High	V_{HM}	2.0 $0.7 * V_{DD}$	V V	TTL CMOS
3	Rise/Fall Threshold Voltage Low	V_{LM}	0.8 $0.3 * V_{DD}$	V V	TTL CMOS

* Timing for output signals is based on the worst case result of the combination of TTL and CMOS thresholds.

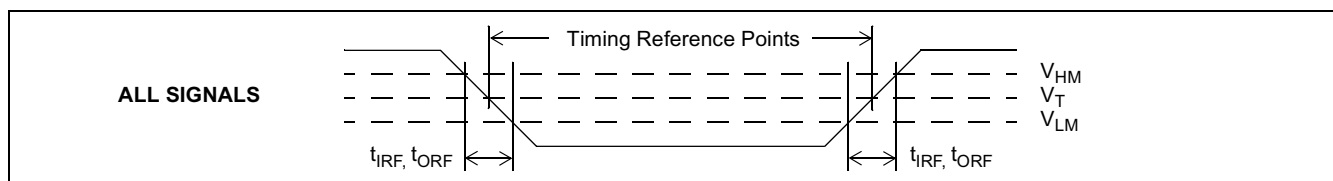

Figure 24 - Timing Parameter Measurement Voltage Levels

AC Electrical Characteristics - Motorola Microprocessor Timing*

	Characteristics	Sym	Min	Typ	Max	Units	Test Conditions
1	\overline{DS} low	t_{DSL}	92			ns	
2	\overline{DS} High	t_{DSH}	33			ns	
3	\overline{CS} Setup	t_{CSS}	0			ns	
4	R/\overline{W} Setup	t_{RWS}	-6			ns	
5	Address Setup	t_{ADS}	15			ns	
6	\overline{CS} Hold	t_{CSH}	0			ns	
7	R/\overline{W} Hold	t_{RWH}	16			ns	
8	Address Hold	t_{ADH}	16.5			ns	
9	Data Delay Read	t_{DDR}			76	ns	$C_L=150pF, R_L=1k\Omega$
10	Data Hold Read	t_{DHR}	8			ns	$C_L=150pF, R_L=1k\Omega$
11	Data Active to High Z Delay	t_{DAZ}		12		ns	$C_L=150pF, R_L=1k\Omega, \text{Note 1}$
12	Data Setup Write	t_{DSW}	0			ns	
13	Data Hold Write	t_{DHW}	13.5			ns	
14	Cycle Time	t_{CYC}		125		ns	

*Typical figures are at 25°C and are for design aid only; not guaranteed and not subject to production testing.

Note 1. High impedance is measured by pulling to the appropriate rail with R_L , with timing corrected to cancel time taken to discharge C_L .

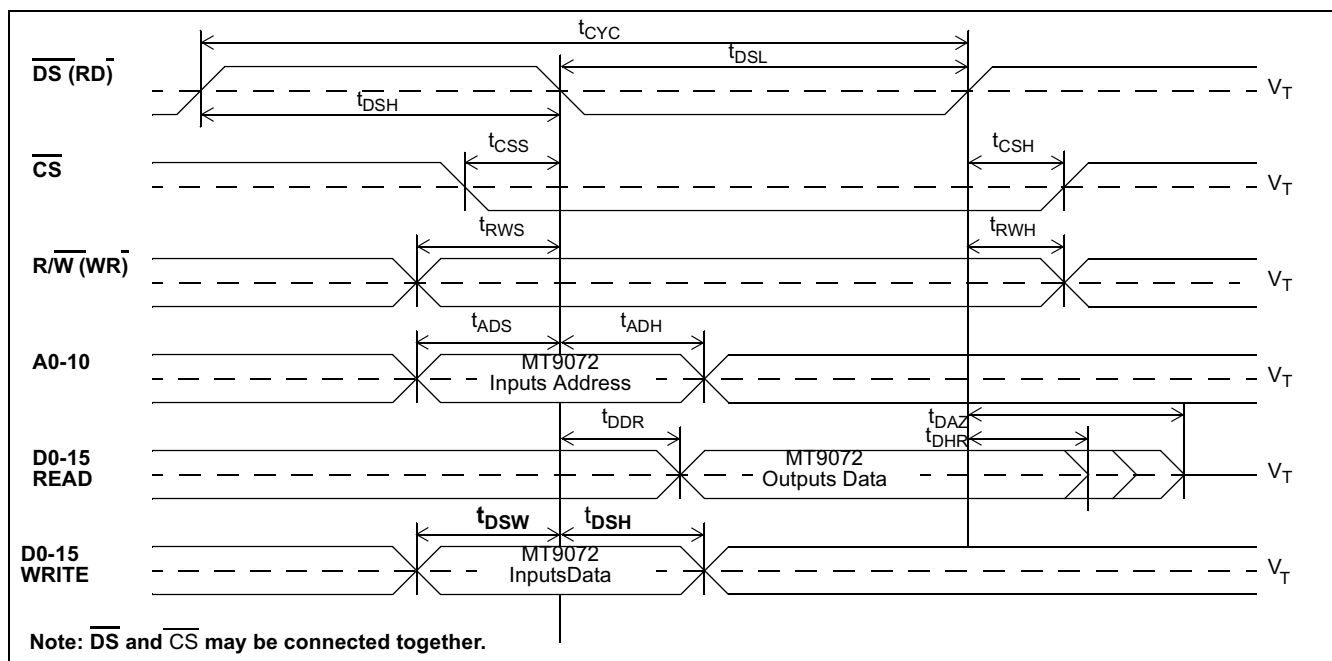

Figure 25 - Motorola Microprocessor Timing

AC Electrical Characteristics - Intel Microprocessor Timing*

	Characteristics	Sym	Min	Typ	Max	Units	Test Conditions
1	\overline{RD} low	$t_{RD L}$	102			ns	
2	\overline{RD} High	$t_{RD H}$	13			ns	
3	\overline{WR} low	$t_{WR L}$	57			ns	
4	\overline{WR} High	$t_{WR H}$	53			ns	
5	\overline{CS} Setup	$t_{CS S}$	0			ns	
6	\overline{CS} Hold	$t_{CS H}$	0			ns	
7	Address Setup	$t_{AD S}$	-5			ns	
8	Address Hold	$t_{AD H}$	-5			ns	
9	Data Delay Read	$t_{DD R}$			76.5	ns	$C_L=150pF, R_L=1k\Omega$.
10	Data Hold Read	$t_{DH R}$	8			ns	$C_L=150pF, R_L=1k\Omega$
11	Data Active to High Z Delay	$t_{DA Z}$	12			ns	$C_L=150pF, R_L=1k\Omega$, Note 1
12	Data Setup Write	$t_{DS W}$	0.5			ns	
13	Data Hold Write	$t_{DH W}$	13			ns	
14	Cycle Time	$t_{CY C}$	115				

*Typical figures are at 25°C and are for design aid only: not guaranteed and not subject to production testing.
 Note 1. High impedance is measured by pulling to the appropriate rail with R_L , with timing corrected to cancel time taken to discharge C_L .

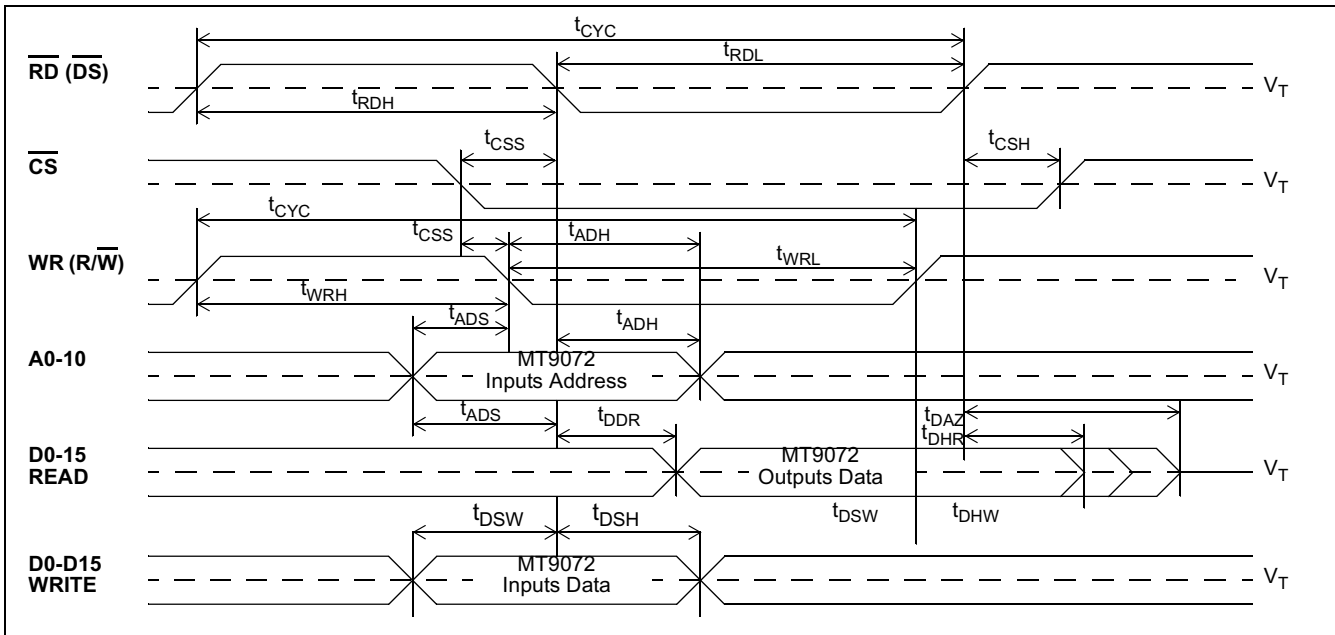

Figure 26 - Intel Microprocessor Timing

AC Electrical Characteristics - GCI 2.048Mb/s Timin

	Characteristics	Sym	Min	Typ	Max	Units	Test Conditions
1	DCL Clock Width High or Low	t_{DCLW}	100	122	144	ns	
2	Frame Pulse Setup	t_{FSCS}	50			ns	
3	Frame Pulse Hold	t_{FSCH}	50			ns	
4	Serial Input Setup	t_{SIS}	30			ns	
5	Serial Input Hold	t_{SIH}	50			ns	
6	Serial Output Delay	t_{SOD}			125	ns	150pF load on CSto and DSTo

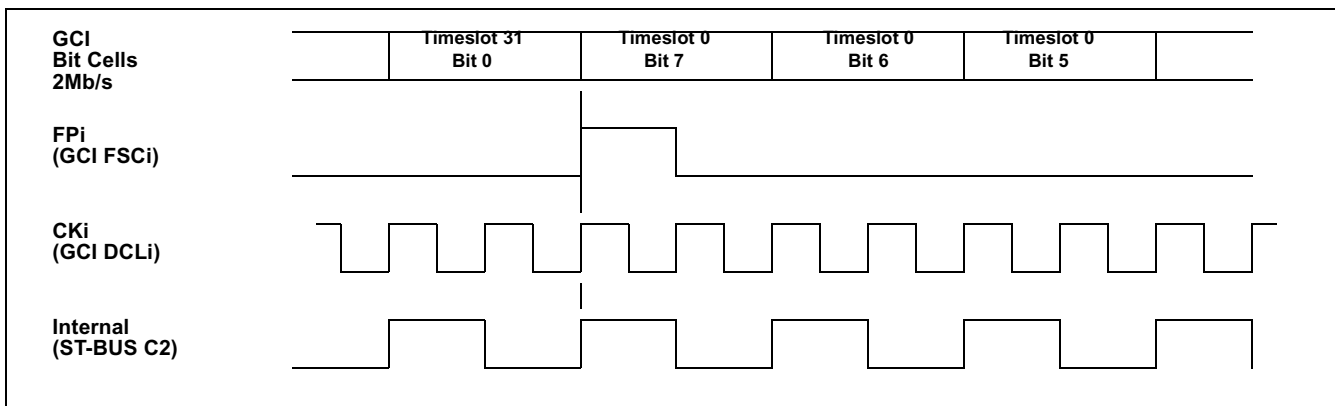

Figure 27 - GCI 2.048Mb/s Fractional Timing Diagram

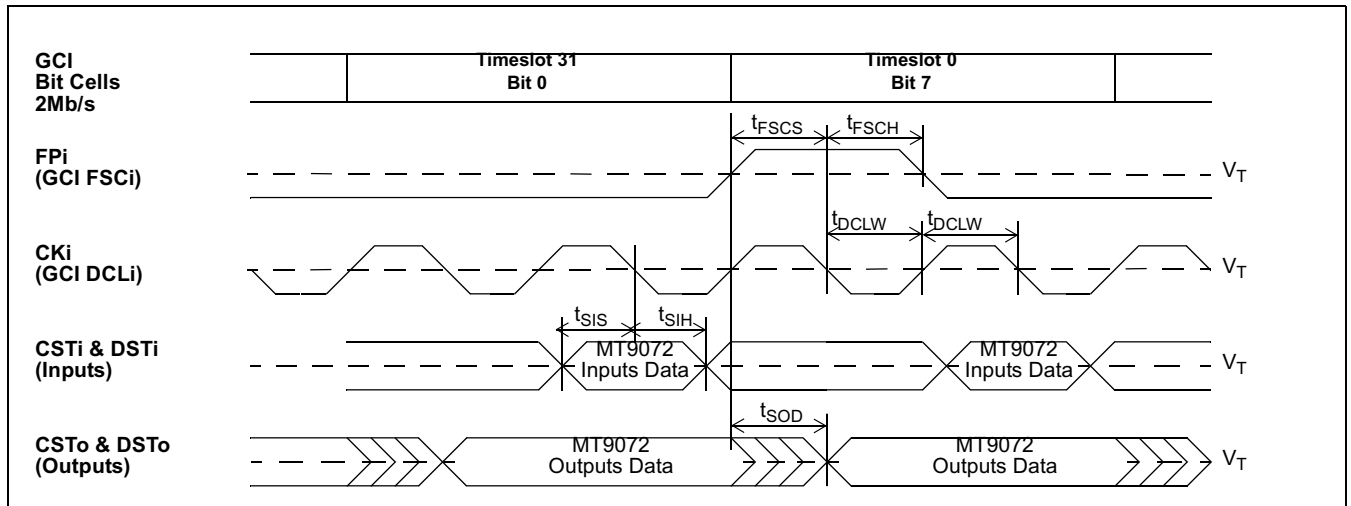

Figure 28 - GCI 2.048 Mb/s Timing Diagram

AC Electrical Characteristics - ST-BUS 2.048Mb/s Timing

	Characteristics	Sym	Min	Typ	Max	Units	Test Conditions
1	C2i Clock Width High or Low	t _{C2W}	222	244	266	ns	
2	C4i Clock Width High or Low	t _{C4W}	100	122	144	ns	
3	Frame Pulse Setup	t _{FPS}	50			ns	
4	Frame Pulse Hold	t _{FPH}	50			ns	
6	Serial Input Setup	t _{SIS}	30			ns	
7	Serial Input Hold	t _{SIH}	50			ns	
8	Serial Output Delay	t _{SOD}		90	125	ns	150pF load on CSTo and DSTo

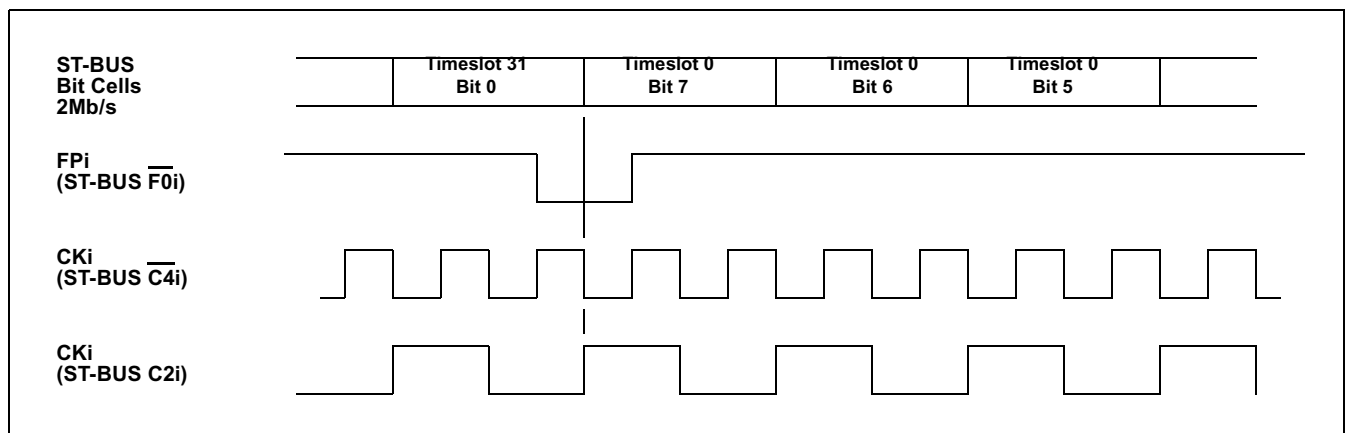

Figure 29 - ST-BUS 2.048Mb/s Functional Timing Diagram

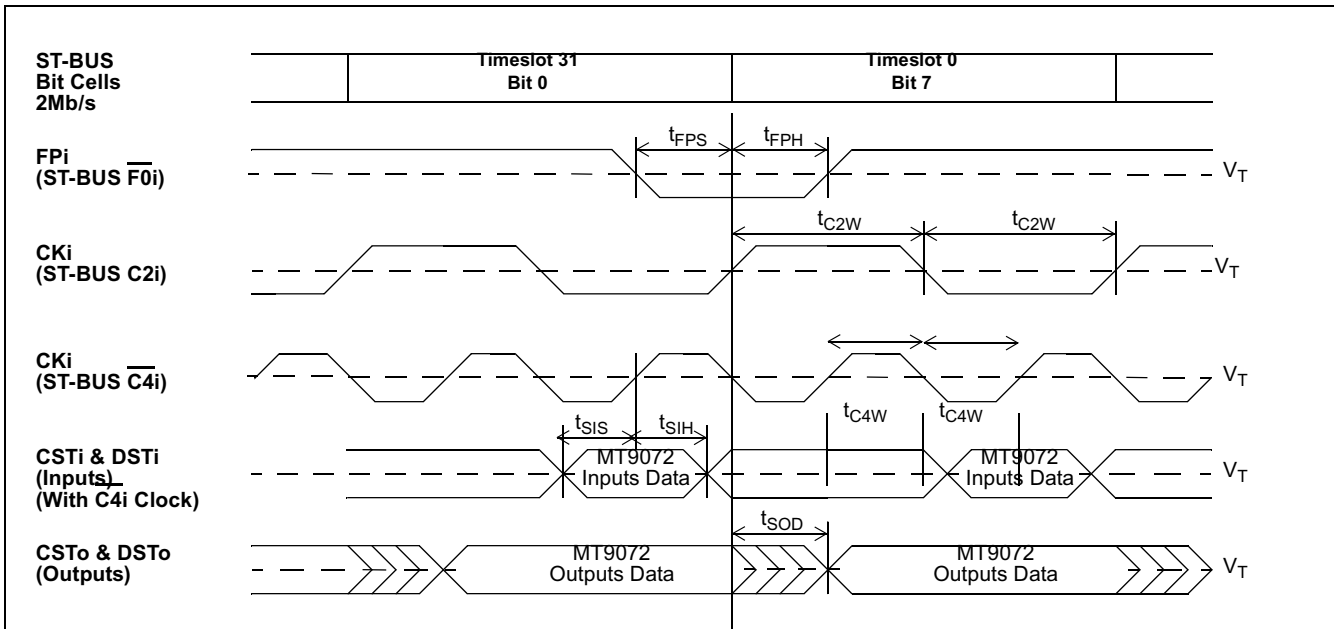

Figure 30 - ST-BUS 2.048Mb/s Timing

AC Electrical Characteristics - ST-BUS 8.192Mb/s Timing

	Characteristics	Sym	Min	Typ	Max	Units	Test Conditions
1	CKi Clock Width High or Low	t_{CKW}	25	31	35	ns	
3	Frame Pulse Setup	t_{FPS}	10		60	ns	
4	Frame Pulse Hold	t_{FPH}	20		60	ns	
6	Serial Input Setup	t_{SIS}	10			ns	
7	Serial Input Hold	t_{SIH}	20			ns	
8	Serial Output Delay	t_{SOD}			55	ns	150pF load on CSTo and DSTo

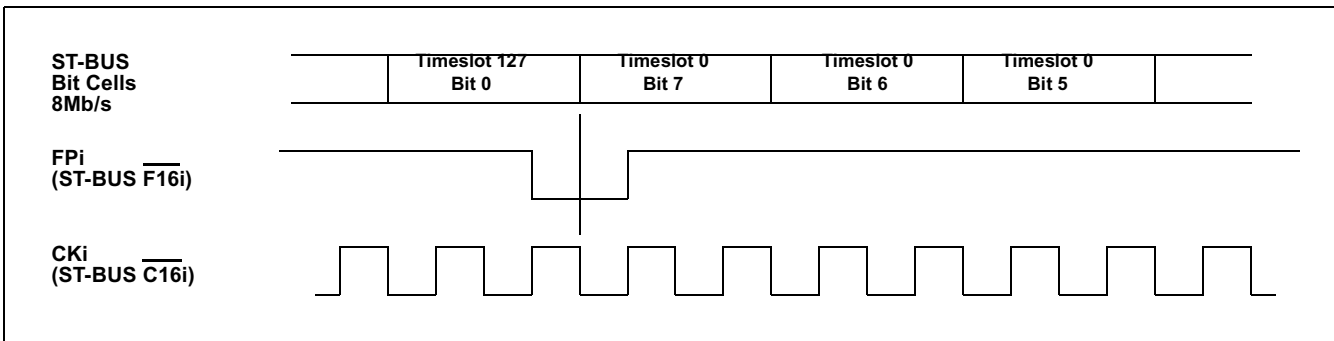

Figure 31 - ST-BUS 8.192Mb/s Functional Timing Diagram

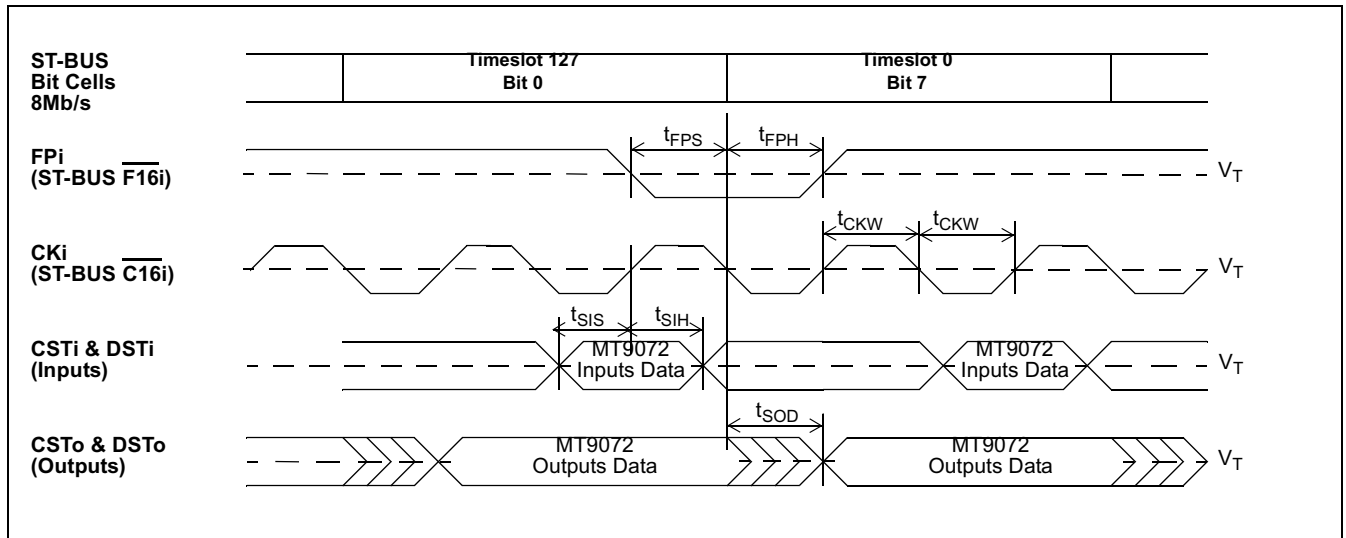

Figure 32 - ST-BUS 8.192Mb/s Timing

AC Electrical Characteristics - IMA Backplane Timing

	Characteristics	Sym	Min	Typ	Max	Units	Test Conditions
1	C1.5i Clock Width High or Low	$t_{C1.5W}$	295	324	353	ns	
2	Frame Pulse Setup	t_{FPS}	50			ns	
3	Frame Pulse Hold	t_{FPH}	50			ns	
4	Serial Input Setup	t_{SIS}	30			ns	
5	Serial Input Hold	t_{SIH}	50			ns	
6	Clock output delay	t_{cod}	50			ns	
7	Serial Output Delay	t_{SOD}	20	90	125	ns	150pF load on CSTo and DSTo

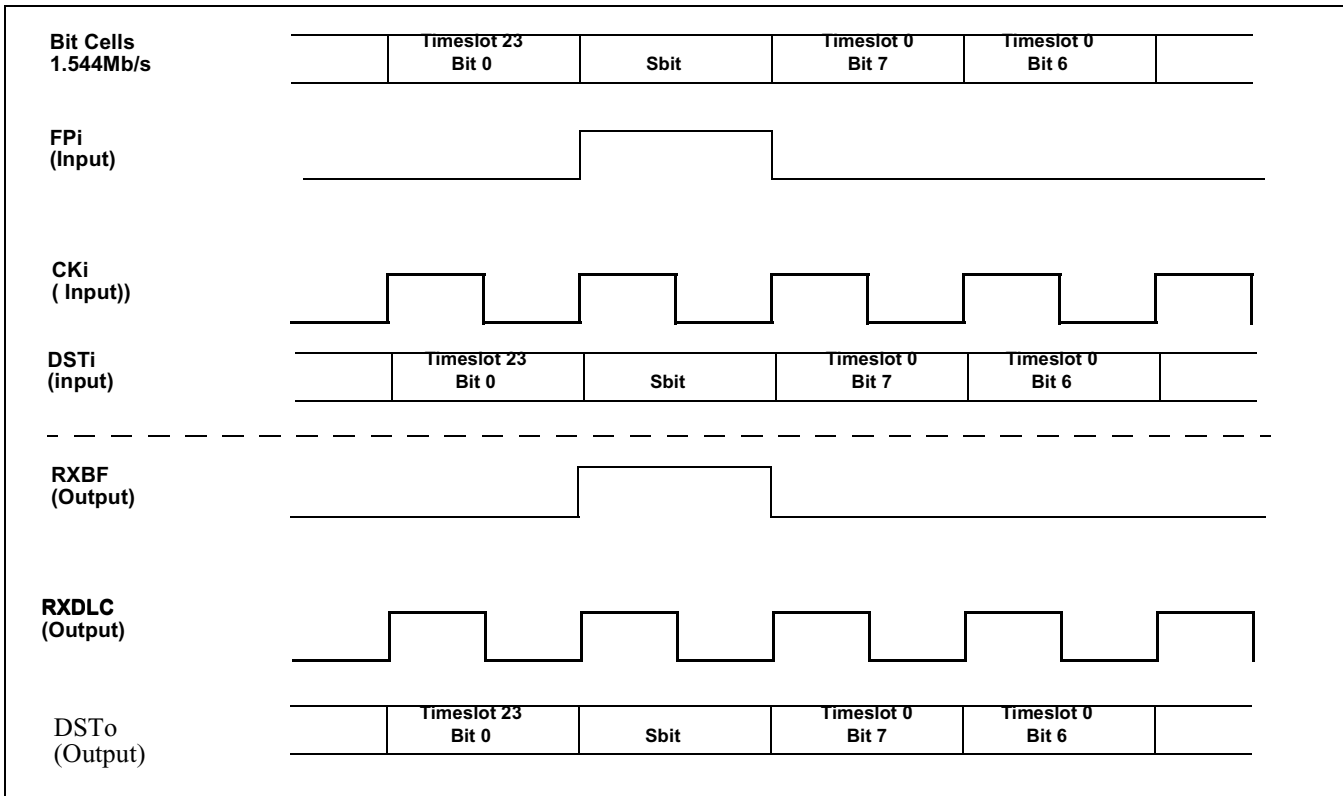
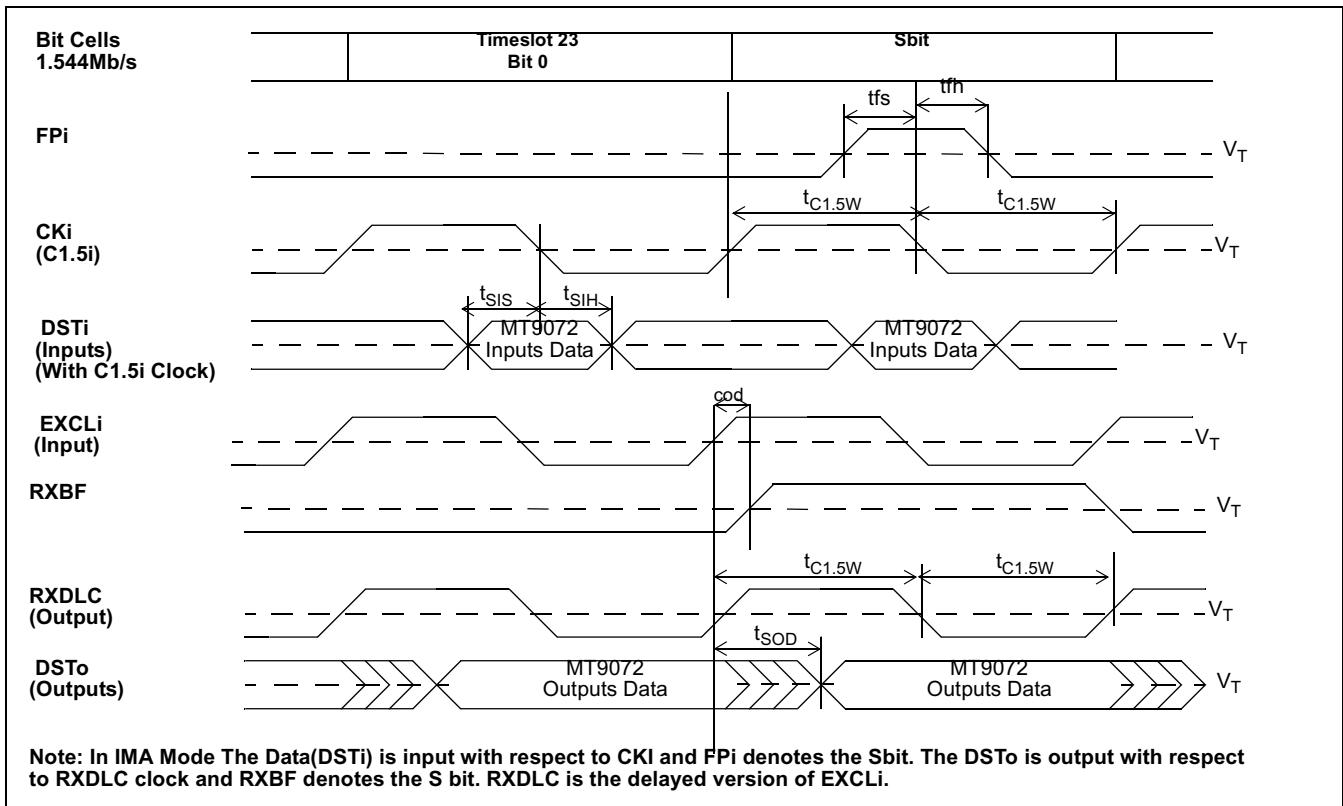

Figure 33 - IMA Functional Timing Diagram



Note: In IMA Mode The Data(DSTi) is input with respect to CKi and FPI denotes the Sbit. The DSTo is output with respect to RXDLC clock and RXBF denotes the S bit. RXDLC is the delayed version of EXCLi.

Figure 34 - IMA Mode Timing Diagram

AC Electrical Characteristics - Transmit Multiframe Timing

	Characteristics	Sym	Min	Typ	Max	Units	Test Conditions
1	Transmit Multiframe Setup	t_{MS}	50			ns	
2							

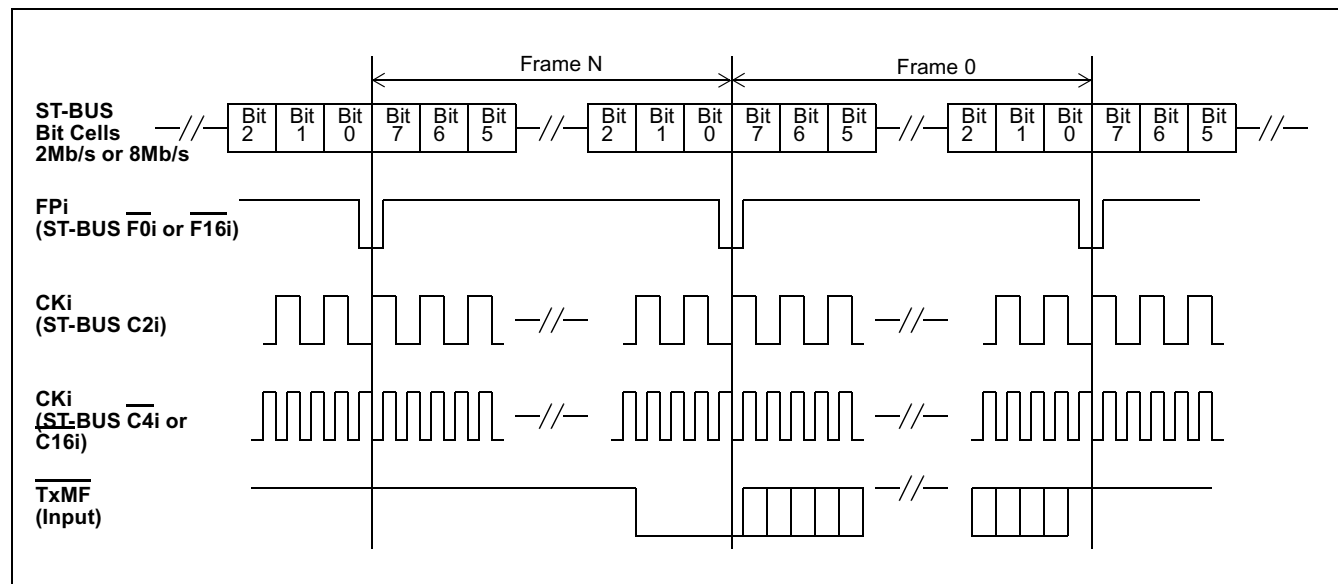

Figure 35 - Transmit Multiframe Functional Timing

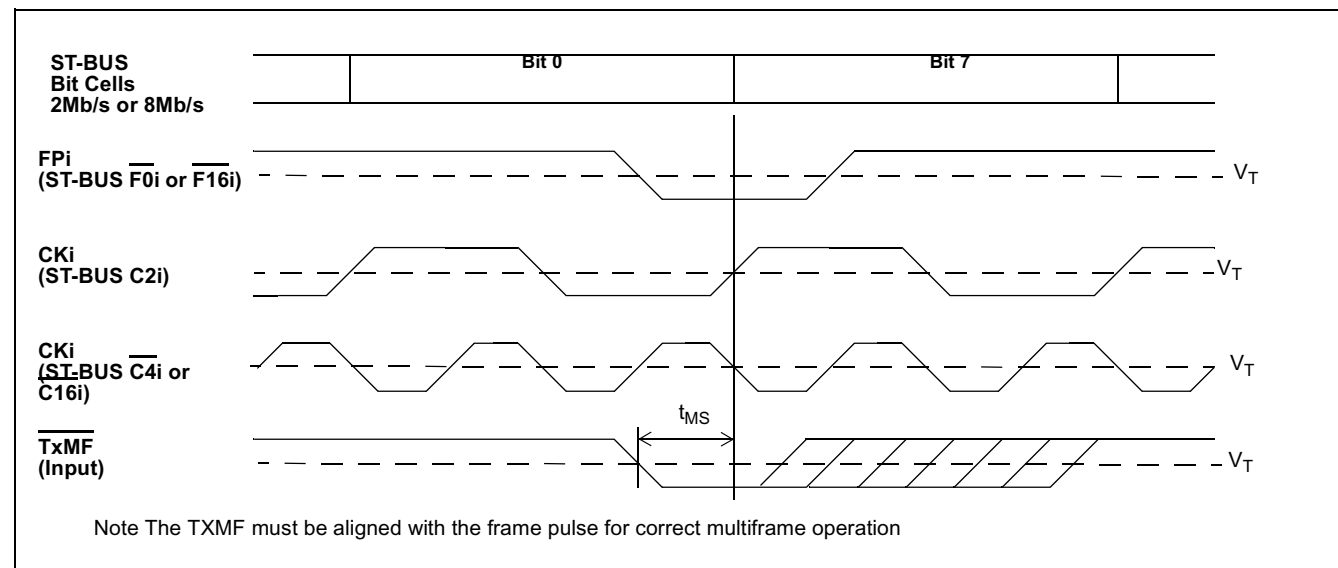

Figure 36 - Transmit Multiframe Timing

AC Electrical Characteristics - Receive Multiframe Timing with TX8KE_n Reset

	Characteristics	Sym	Min	Typ	Max	Units	Test Conditions
1	Receive Multiframe Output Delay	t_{MOD}			55	ns	150pF load on \overline{RxMF}

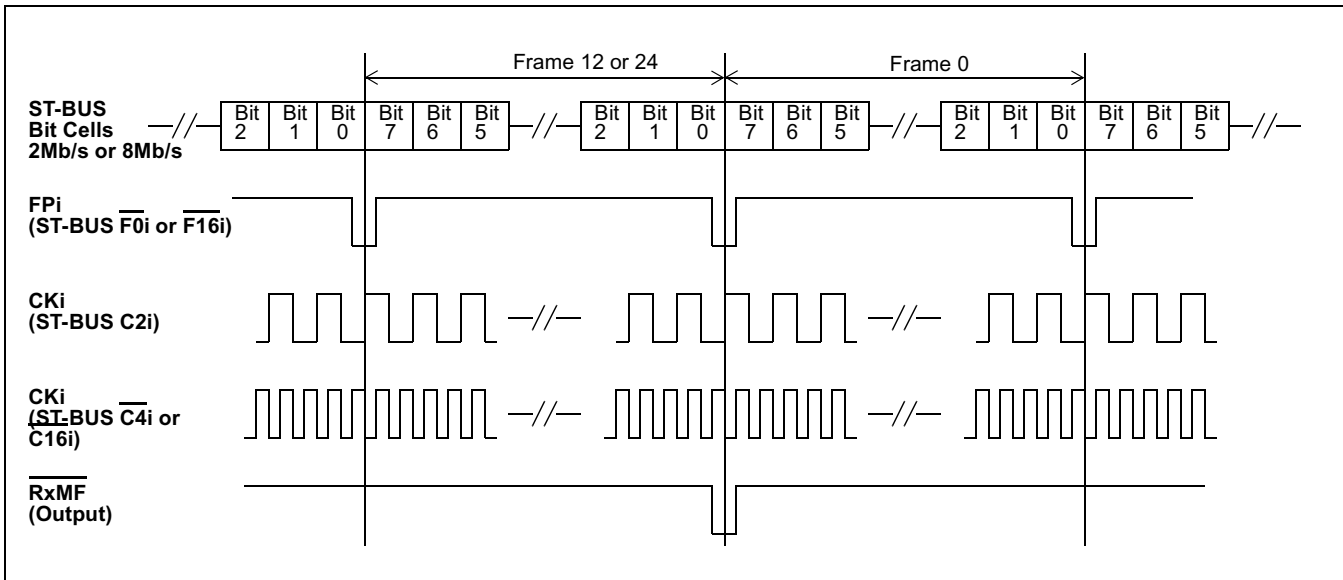

Figure 37 - Receive Multiframe Functional Timing

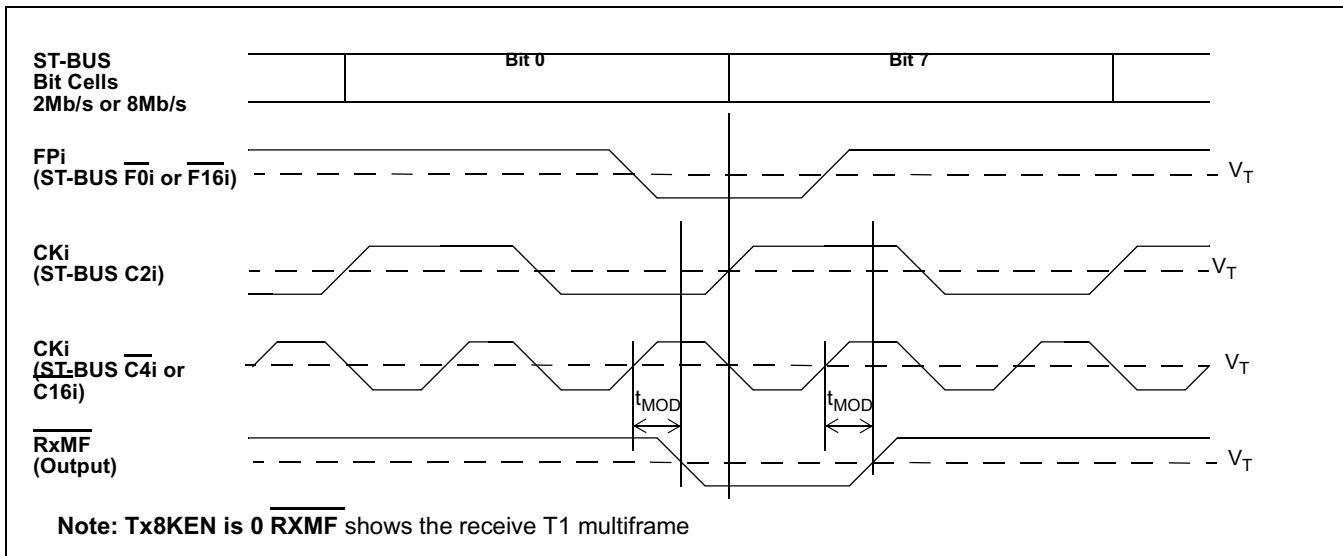

Figure 38 - Receive Multiframe Timing

AC Electrical Characteristics - Receive Multiframe Timing with TX8KEN Set

	Characteristics	Sym	Min	Typ	Max	Units	Test Conditions
1	RXMF Output Delay	t_{TFOD}		20		ns	150pF

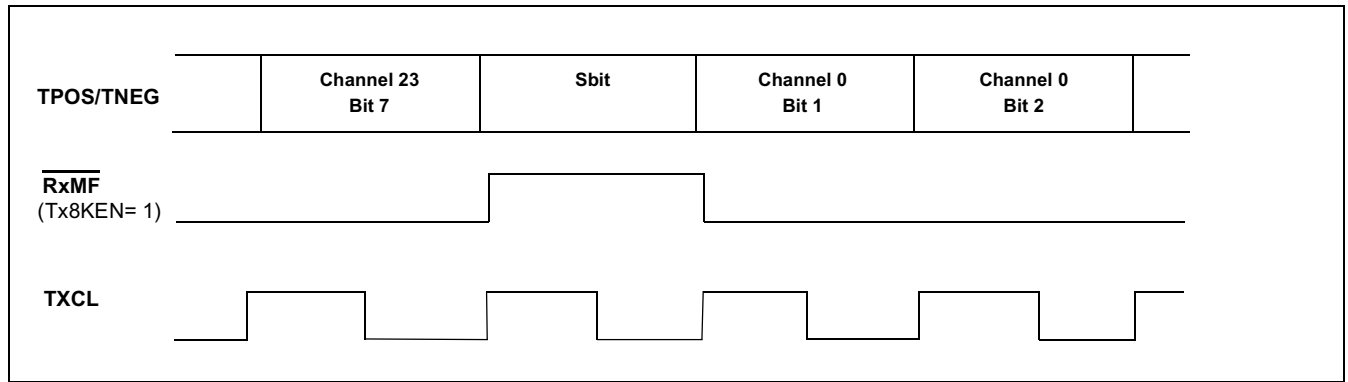

Figure 39 - Receive Multiframe Timing with TX8KE n Set Functional Timing Diagram

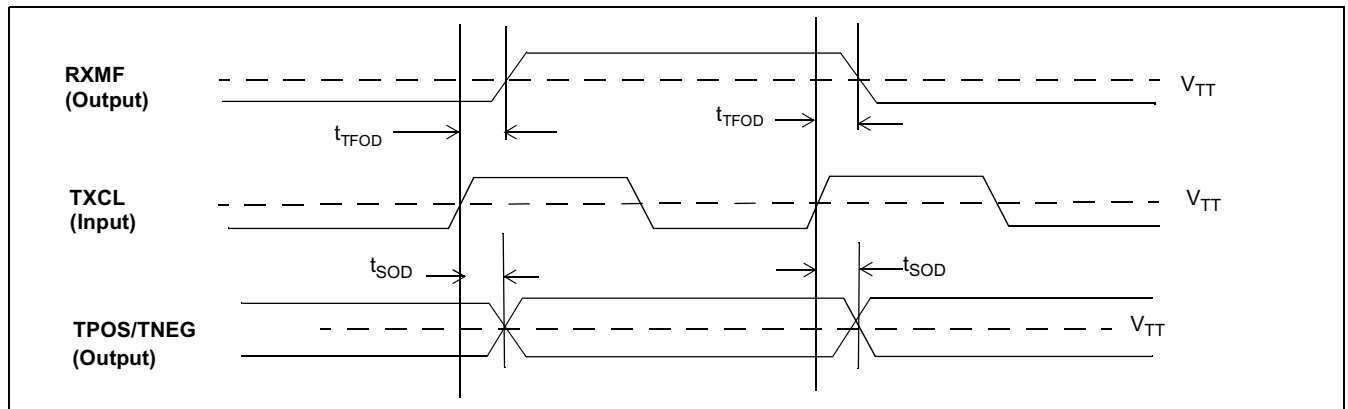

Figure 40 - Receive Multiframe Timing with TX8KE n Set Timing Diagram

AC Electrical Characteristics - Transmit Data Link Timing

	Characteristics	Sym	Min	Typ	Max	Units	Test Conditions
1	Clock Delay	t_{CD}		100		ns	150pF load on $\overline{\text{TxDLC}}$
2	Enable Delay	t_{ED}		100		ns	150pF load on $\overline{\text{TxDLC}}$
3	Data Setup	t_{DS}		50		ns	150pF load on $\overline{\text{TxDLC}}$
4	Data Hold	t_{DH}		50		ns	150pF load on $\overline{\text{TxDLC}}$

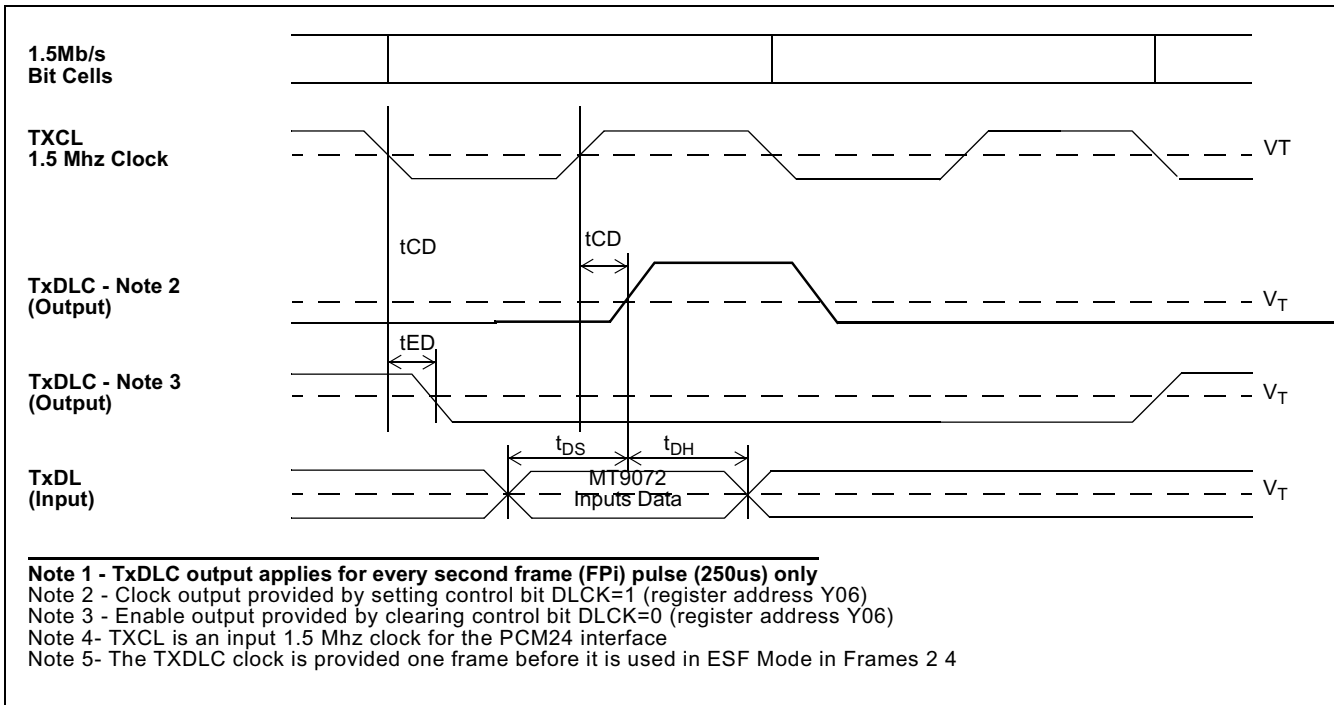

Figure 41 - Transmit Data Link Pin Timing

AC Electrical Characteristics - Transmit Data Link Timing

	Characteristics	Sym	Min	Typ	Max	Units	Test Conditions
1	Clock Delay	t_{CD}		100		ns	150pF load on \overline{RxDLC}
2	Enable Delay	t_{ED}		100		ns	150pF load on \overline{RxDLC}
3	Data Delay Read	t_{DDR}		100		ns	150pF load on \overline{RxDL}
4	Data Hold Read	t_{DHR}		50		ns	150pF load on \overline{RxDL}

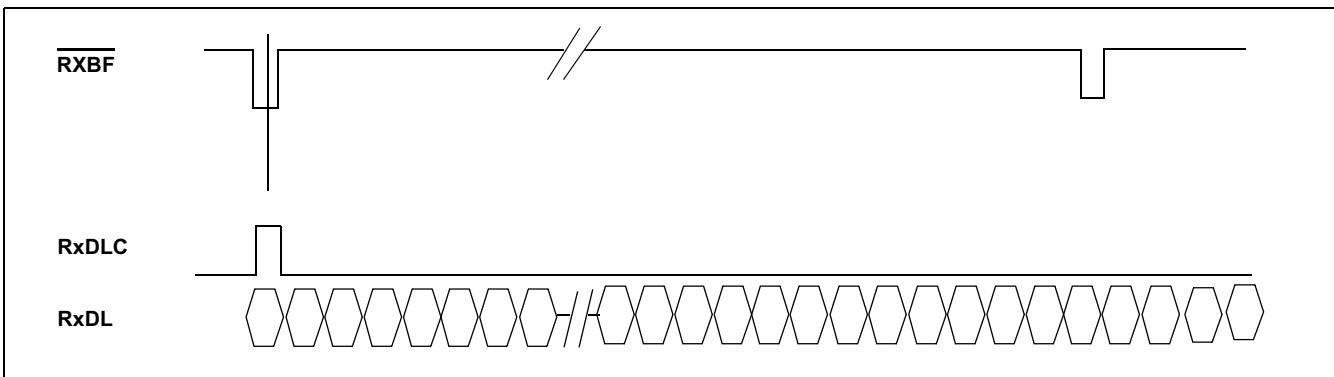

Figure 42 - Receive Data Link Functional Diagram

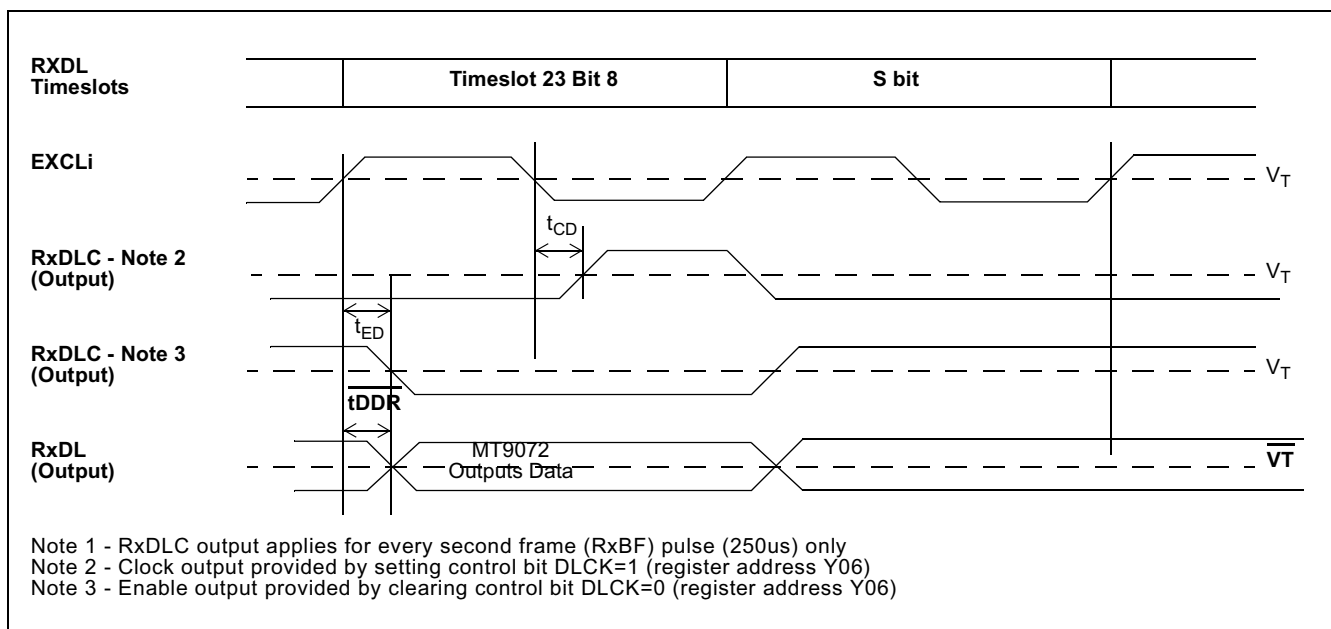

Figure 43 - Receive DataLink Timing Diagram

AC Electrical Characteristics - Receive Basic Frame Pulse Pin Timing

	Characteristics	Sym	Min	Typ	Max	Units	Test Conditions
1	Basic Frame Output Delay	t_{BD}		100		ns	150pF load on \overline{RxBF}

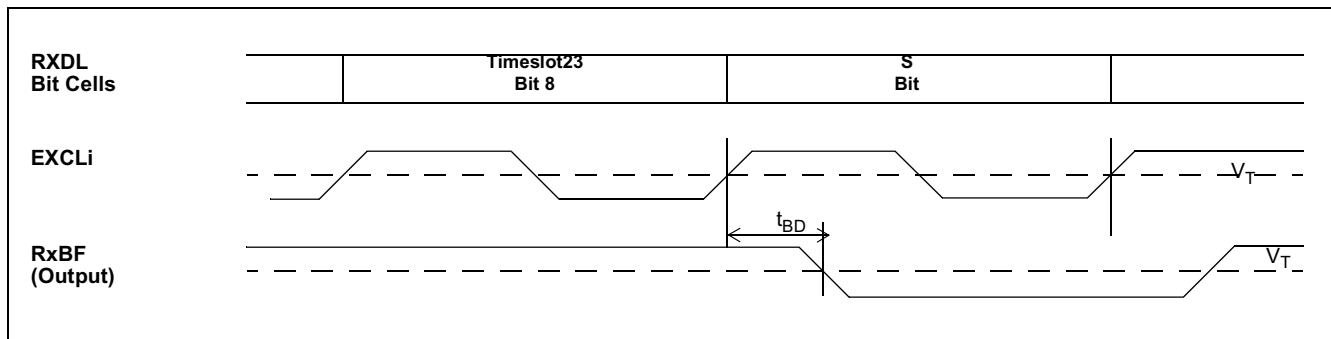

Figure 44 - Receive Basic Frame Pulse Pin Timing

AC Electrical Characteristics - PCM24 Transmit Timing

	Characteristics	Sym	Min	Typ	Max	Units	Test Conditions
1	Transmit Delay	t_{TD}		50		ns	150pF load on TPOS and TNEG
2	Transmit Delay in RZ mode	t_{rTD}		200		ns	150pF load on TPOS and TNEG
3	Transmit Invalid in RZ Mode	t_{rDI}		200		ns	150pF load on TPOS and TNEG

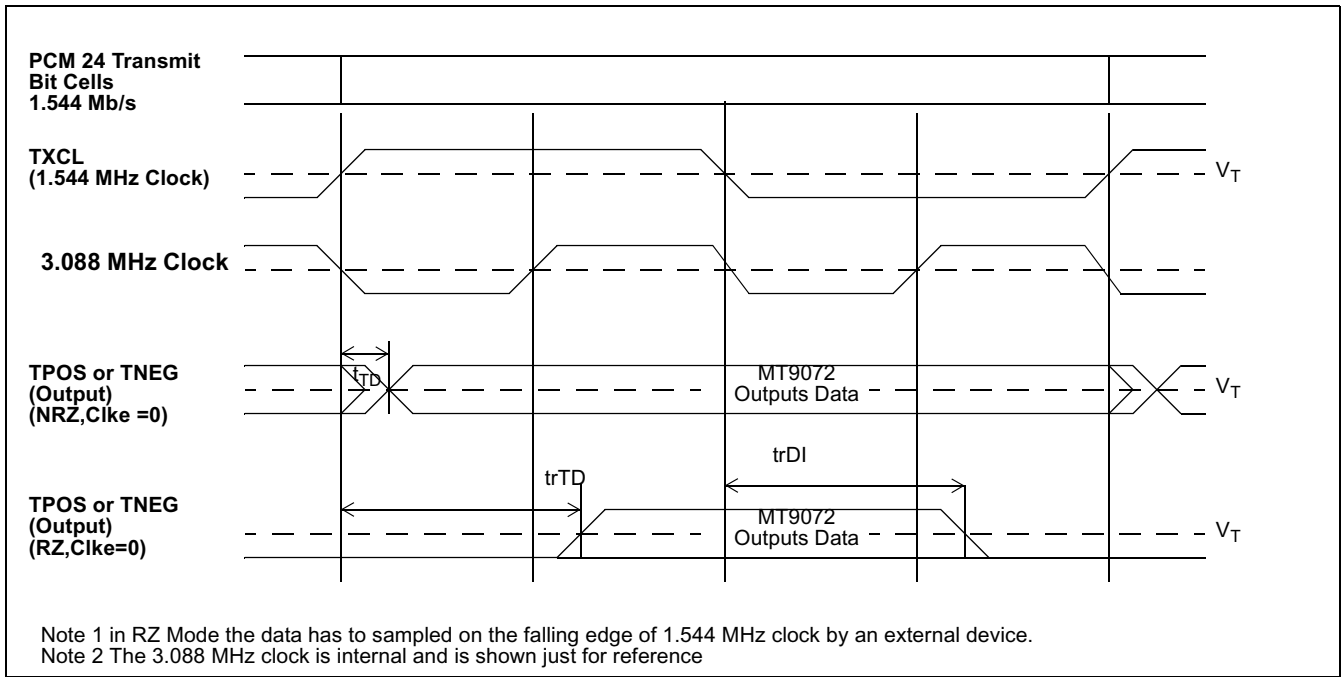

Figure 45 - PCM 24 Transmit Timing

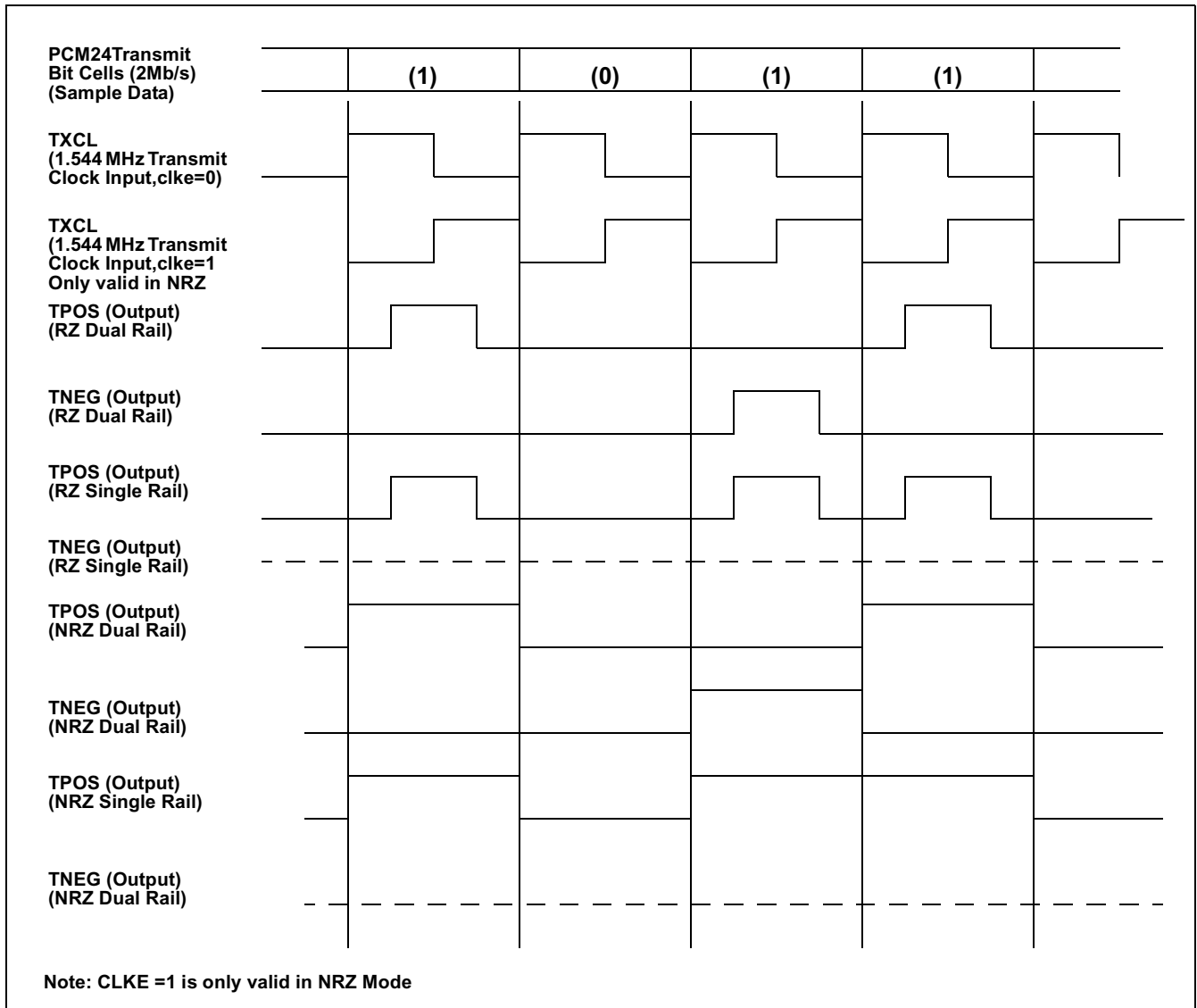

Figure 46 - PCM24 Transmit Functional Timing

AC Electrical Characteristics - PCM24 Receive Timing

	Characteristics	Sym	Min	Typ	Max	Units	Test Conditions
1	Receive Setup	t_{RS}		50		ns	
2	Receive Hold	t_{RH}		50		ns	

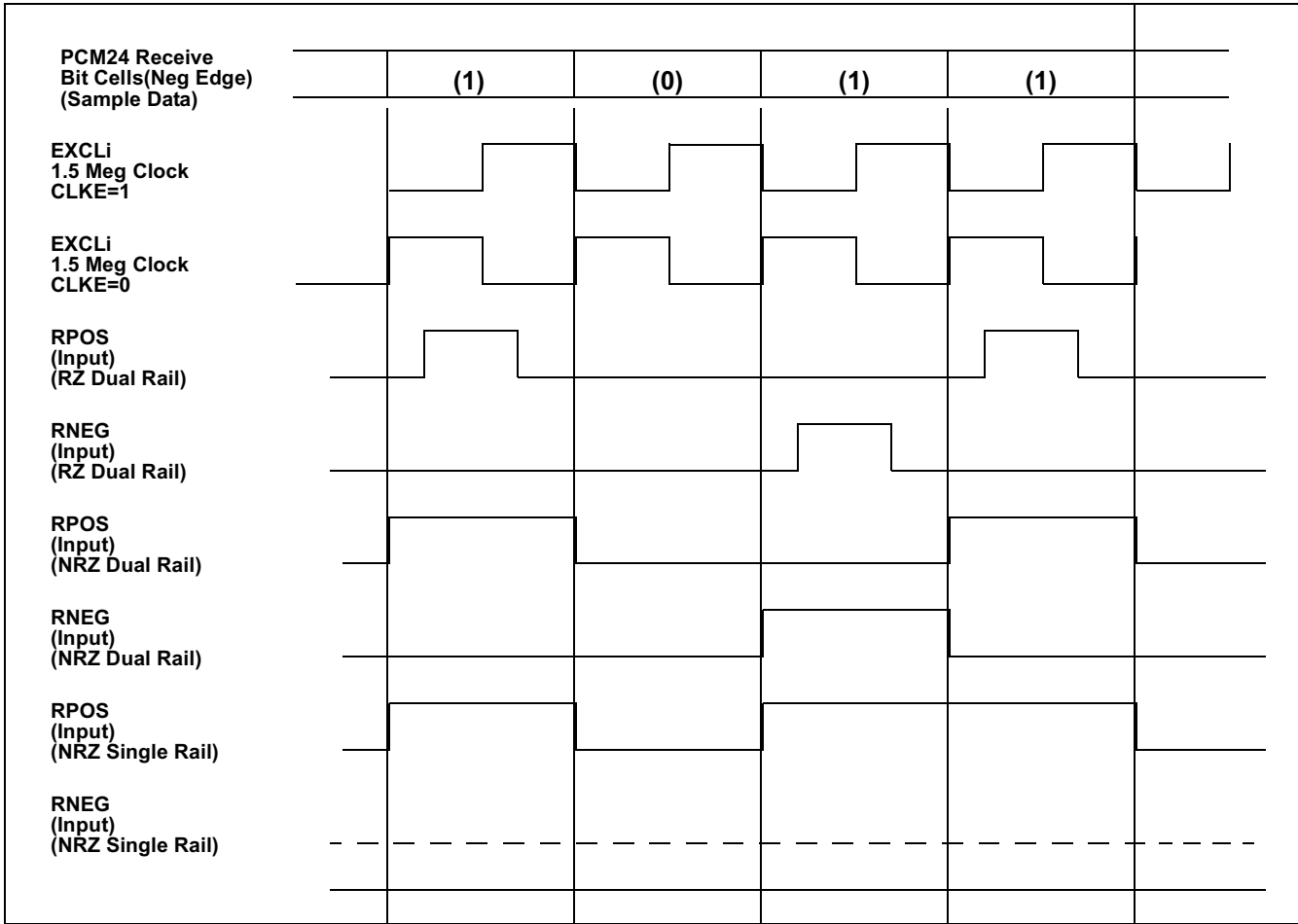

Figure 47 - PCM24 Receive Functional Timing

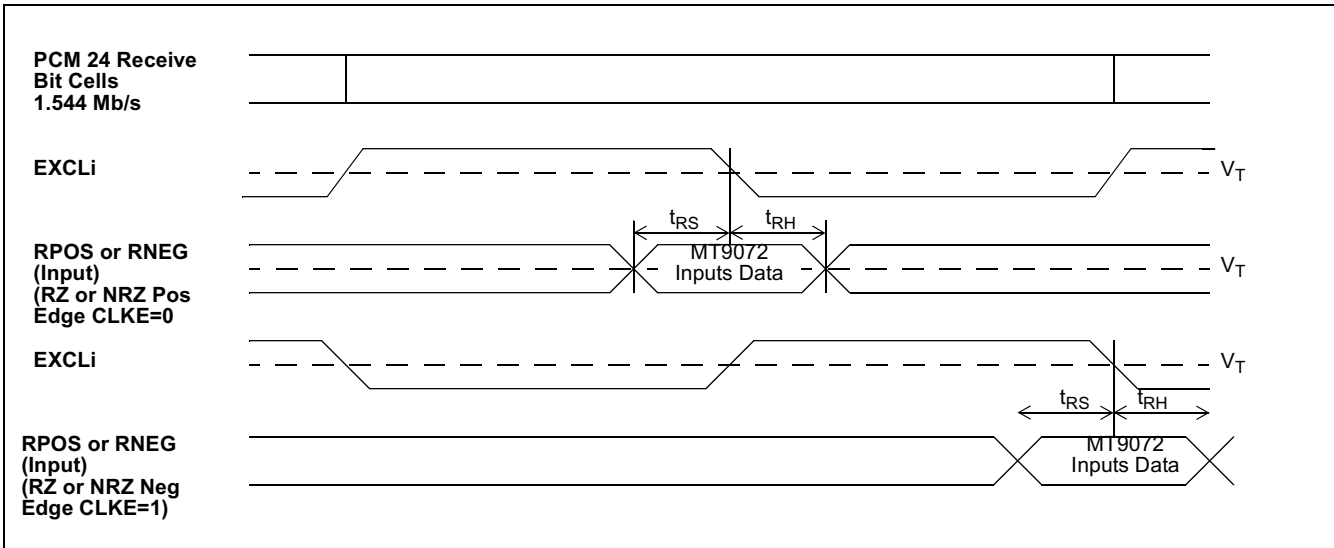

Figure 48 - PCM24 Receive Timing

17.0 AC Electrical Characteristics - PCM24 and ST-BUS Frame Format

In both the transmit and receive directions, PCM24 LSB maps to ST-BUS LSB.

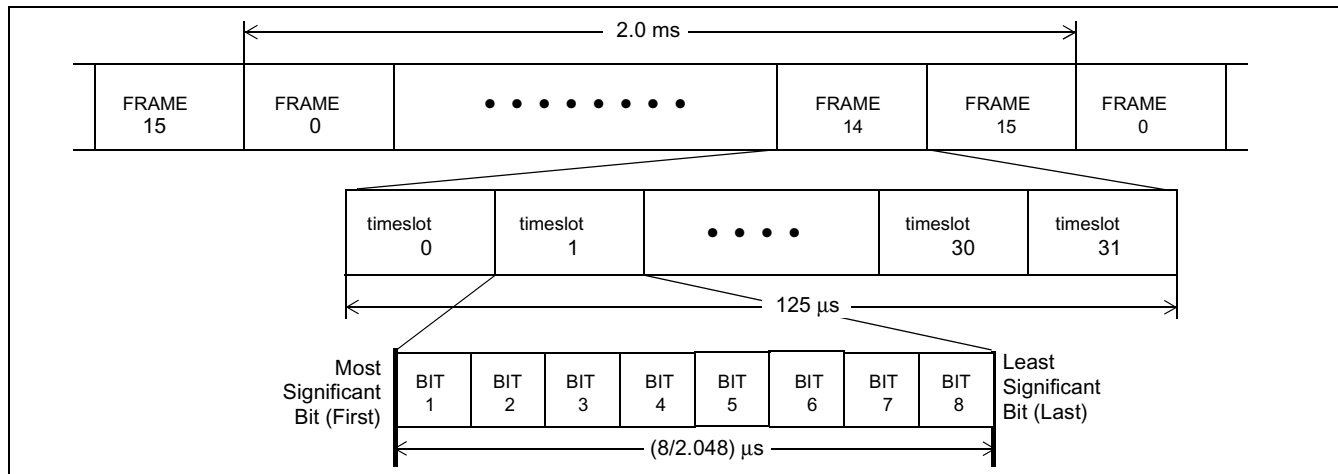

Figure 49 - PCM 24 Format

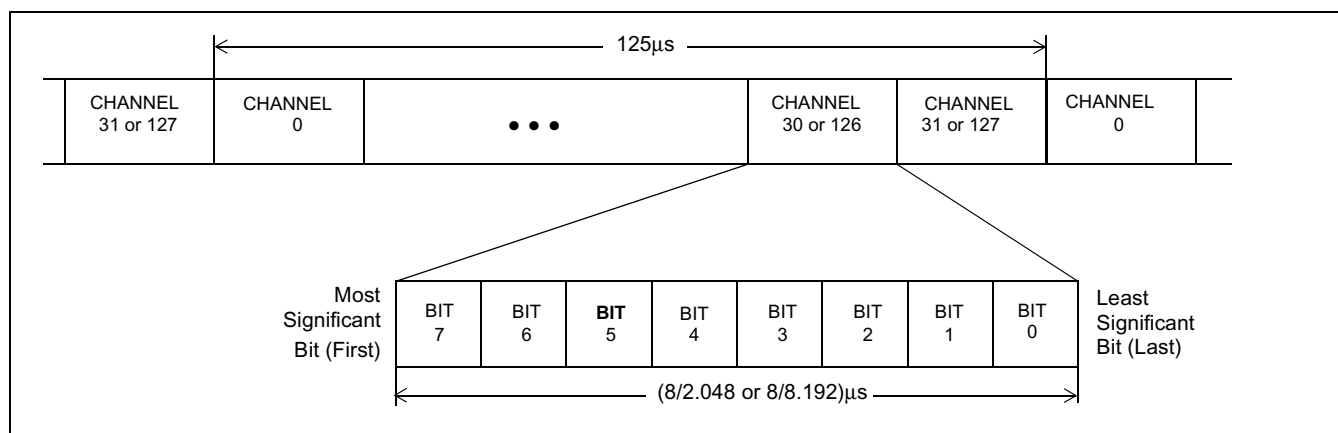

Figure 50 - ST-BUS Format

E1 Mode

Absolute Maximum Ratings*

	Parameter	Symbol	Min	Max	Units
1	Supply Voltage	V_{DD}	-0.3	5.5	V
2	Voltage at Digital Inputs	V_I	-0.3	$V_{DD} + 0.3$	V
3	Current at Digital Inputs	I_I		30	mA
4	Voltage at Digital Outputs	V_O	-0.3	$V_{DD} + 0.3$	V
5	Current at Digital Outputs	I_O		30	mA
6	Storage Temperature	T_{ST}	-65	150	°C

* Voltages are with respect to ground (VSS) unless otherwise stated.

* Exceeding these values may cause permanent damage. Functional operation under these conditions is not implied.

Recommended Operating Conditions - Voltages are with respect to ground (VSS) unless otherwise stated.

	Characteristics	Sym	Min	Typ	Max	Units	Test Conditions
1	Operating Temperature	T _{OP}	-40	25	85	°C	
2	Supply Voltage 3.3V Nominal	V _{DD}	3.0	3.3	3.6	V	

DC Electrical Characteristics * - Voltages are with respect to ground (VSS) unless otherwise stated

	Characteristics	Sym	Min	Typ [‡]	Max	Units	Test Conditions
1	Input Leakage (Digital Inputs with no pullup's or pulldown's)	I _{IL}		1	10	μA	V _I = 0 to V _{DD}
2	Input Leakage (Digital Inputs with pullup's or pulldown's)	I _{IL}			100	μA	V _I = 0 to V _{DD}
3	High Impedance Leakage (Digital I/O)	I _{OZ}		1	10	μA	V _O = 0 to V _{DD}
4	Supply Current	I _{DD}		20		mA	Outputs unloaded. Transmitting an all 1's signal.
5	Input High Voltage (Digital Inputs)	V _{IH}	0.7 V _{DD}			V	
6	Input Low Voltage (Digital Inputs)	V _{IL}			0.3V _{DD}	V	
7	Output High Voltage (Digital Outputs)	V _{OH}	0.8 V _{DD}			V	I _{OH} =7 mA
8	Output Low Voltage (Digital Outputs)	V _{OL}			0.4	V	I _{OL} =2 mA

* Characteristics are for clocked operation over the ranges of recommended operating temperature and supply voltage.
 ‡ Typical figures are at 25°C and are for design aid only: not guaranteed and not subject to production testing.

AC Electrical Characteristics - Timing Parameter Measurement Voltage Levels* - Voltages are with respect to ground (VSS) unless otherwise stated.

	Characteristics	Sym	Level	Units	Conditions/Notes
1	Threshold Voltage	V _T	1.5 0.5*V _{DD}	V V	TTL CMOS
2	Rise/Fall Threshold Voltage High	V _{HM}	2.0 0.7*V _{DD}	V V	TTL CMOS
3	Rise/Fall Threshold Voltage Low	V _{LM}	0.8 0.3*V _{DD}	V V	TTL CMOS

** Timing for output signals is based on the worst case result of the combination of TTL and CMOS thresholds.
 * See Figure 17.

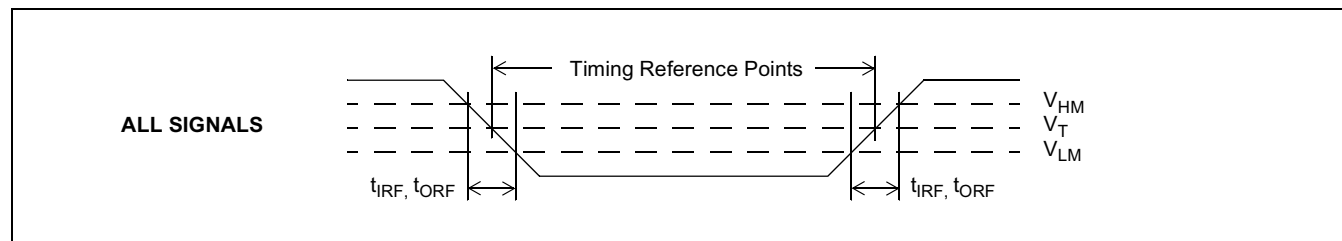

Figure 51 - Timing Parameter Measurement Voltage Levels

AC Electrical Characteristics - Motorola Microprocessor Timing*

	Characteristics	Sym	Min	Typ [‡]	Max	Units	Test Conditions
1	\overline{DS} low	t_{DSL}		115		ns	
2	\overline{DS} High	t_{DSH}		50		ns	
3	\overline{CS} Setup	t_{CSS}	0			ns	
4	\overline{CS} Hold	t_{CSH}	0			ns	
5	R/W Setup	t_{RWS}		15		ns	
6	R/W Hold	t_{RWH}	0			ns	
7	Address Setup	t_{ADS}		15		ns	
8	Address Hold	t_{ADH}		40		ns	
9	Data Delay Read	t_{DDR}		100		ns	$C_L=150pF, R_L=1k\Omega$
10	Data Hold Read	t_{DHR}		5		ns	$C_L=150pF, R_L=1k\Omega$
11	Data Active to High Z Delay	t_{DAZ}		50		ns	$C_L=150pF, R_L=1k\Omega, \text{Note 1}$
12	Data Setup Write	t_{DSW}		15		ns	
13	Data Hold Write	t_{DHW}		25		ns	
14	Cycle Time	t_{CYC}		165		ns	

[‡]Typical figures are at 25°C and are for design aid only; not guaranteed and not subject to production testing.
 Note 1. High impedance is measured by pulling to the appropriate rail with R_L , with timing corrected to cancel time taken to discharge C_L .

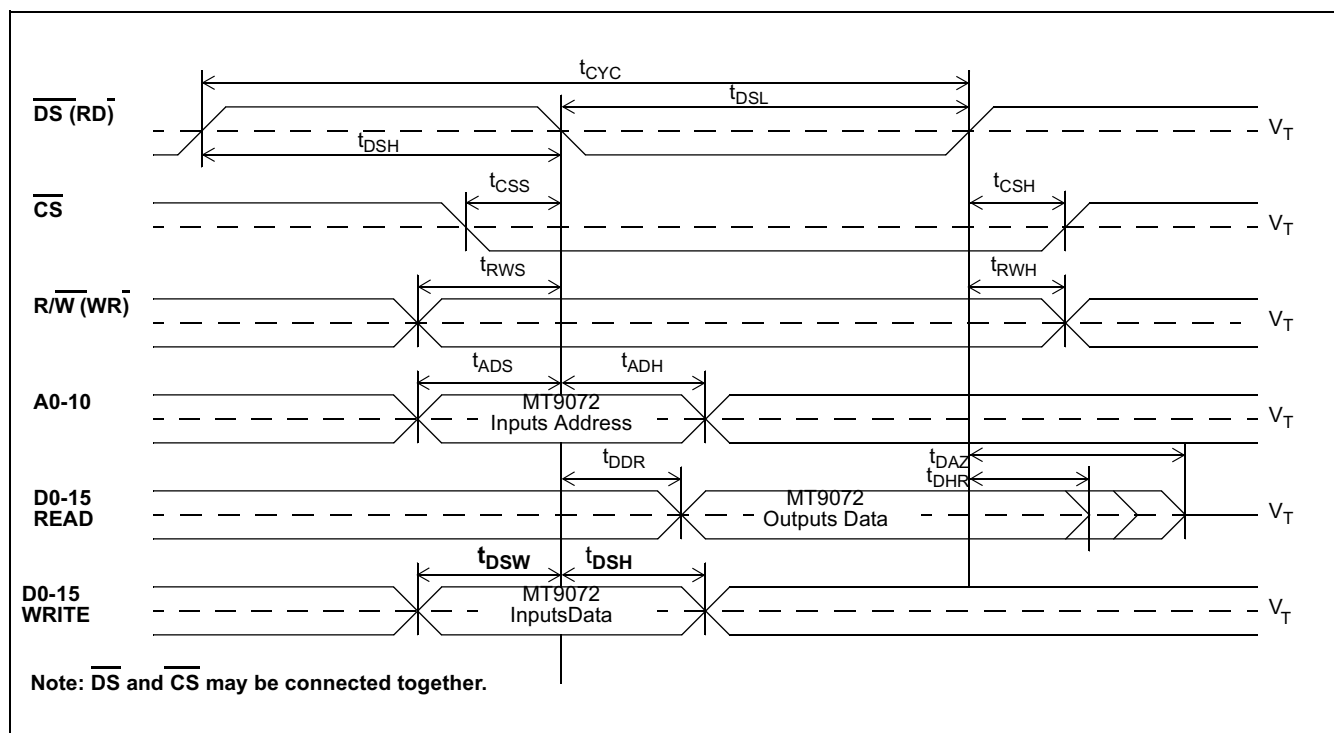

Figure 52 - Motorola Microprocessor Timing

AC Electrical Characteristics - Intel Microprocessor Timing*

	Characteristics	Sym	Min	Typ [‡]	Max	Units	Test Conditions
1	\overline{RD} low	t_{RDL}		115		ns	

AC Electrical Characteristics - Intel Microprocessor Timing*

	Characteristics	Sym	Min	Typ [‡]	Max	Units	Test Conditions
2	\overline{RD} High	t_{RDH}		50		ns	
3	\overline{CS} Setup	t_{CSS}	0			ns	
4	\overline{CS} Hold	t_{CSH}	0			ns	
5	\overline{WR} low	t_{WRL}		70		ns	
6	\overline{WR} High	t_{WRH}		50		ns	
7	Address Setup	t_{ADS}		15		ns	
8	Address Hold	t_{ADH}		40		ns	
9	Data Delay Read	t_{DDR}		100		ns	$C_L=150\text{pF}, R_L=1\text{k}\Omega$
10	Data Hold Read	t_{DHR}		5		ns	$C_L=150\text{pF}, R_L=1\text{k}\Omega$
11	Data Active to High Z Delay	t_{DAZ}		50		ns	$C_L=150\text{pF}, R_L=1\text{k}\Omega$, Note 1
12	Data Setup Write	t_{DSW}		15		ns	
13	Data Hold Write	t_{DHW}		25		ns	
14	Cycle Time	t_{CYC}		165			

[‡]Typical figures are at 25°C and are for design aid only; not guaranteed and not subject to production testing.

Note 1. High impedance is measured by pulling to the appropriate rail with R_L , with timing corrected to cancel time taken to discharge C_L .

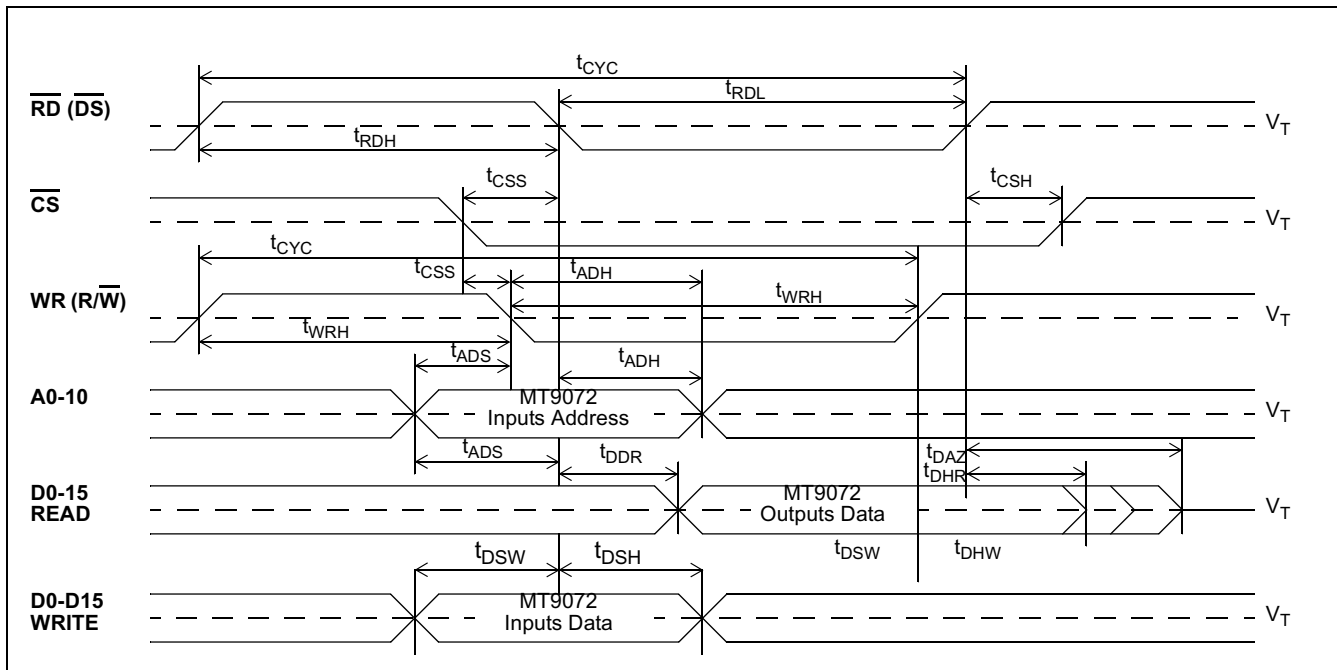

Figure 53 - Intel Microprocessor Timing

AC Electrical Characteristics - ST-BUS 2.048Mb/s Timing

	Characteristics	Sym	Min	Typ	Max	Units	Test Conditions
1	$\overline{C4i}$ Clock Width High or Low	t_{C4W}	100	122	144	ns	
2	Frame Pulse Setup	t_{F0S}	50			ns	
3	Frame Pulse Hold	t_{F0H}	50			ns	
4	Serial Input Setup	t_{SIS}	30			ns	

AC Electrical Characteristics - ST-BUS 2.048Mb/s Timing

	Characteristics	Sym	Min	Typ	Max	Units	Test Conditions
5	Serial Input Hold	t_{SIH}	50			ns	
6	Serial Output Delay	t_{SOD}			125	ns	150pF load on CSto and DSto

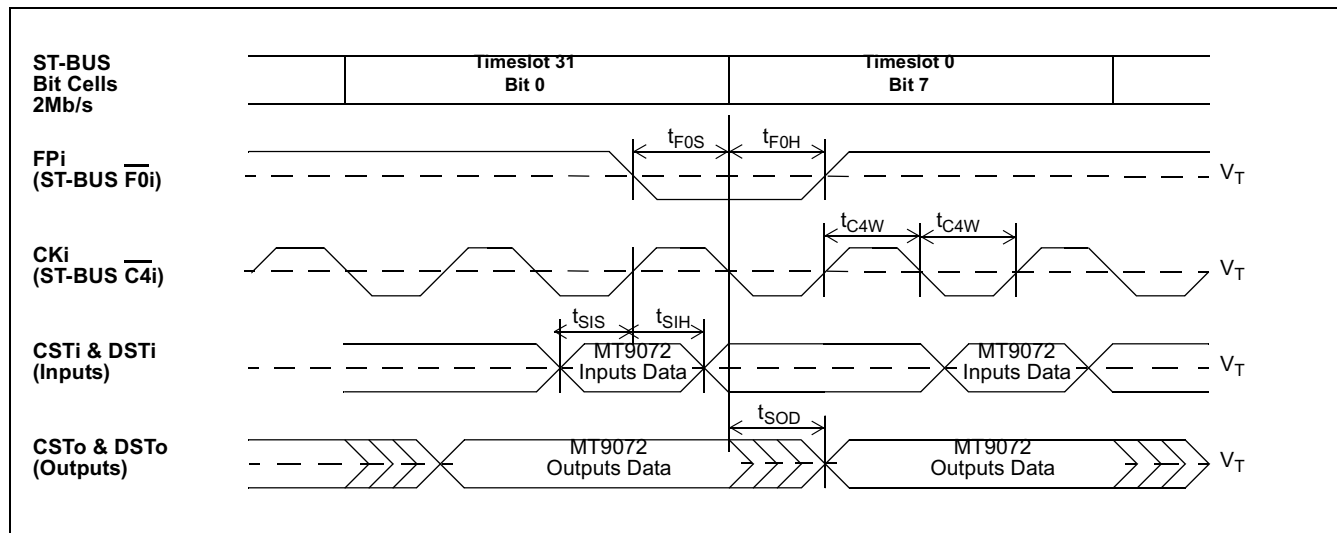

Figure 54 - ST-BUS 2.048Mb/s Timing

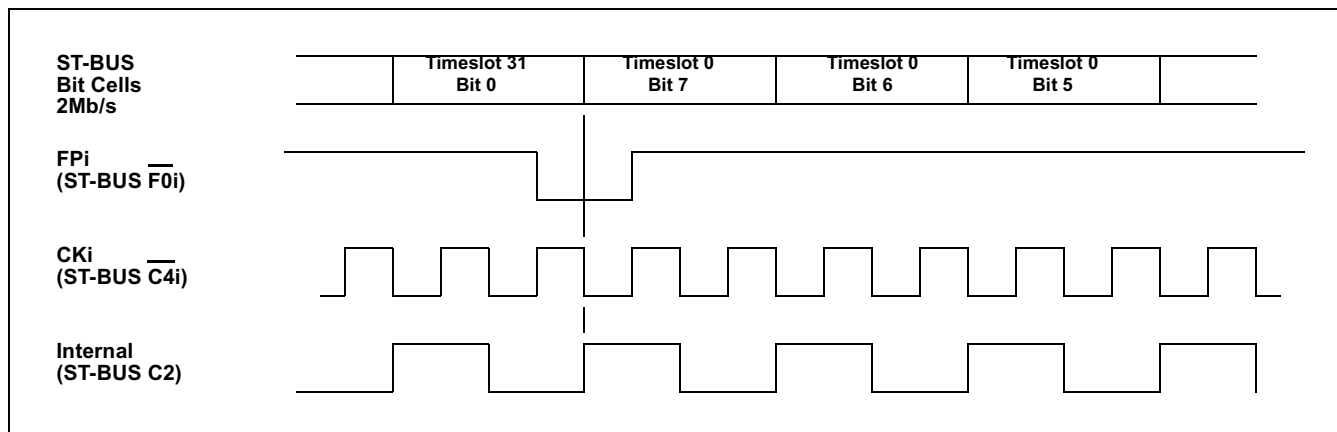

Figure 55 - ST-BUS 2.048Mb/s Functional Timing Diagram

AC Electrical Characteristics - GCI 2.048Mb/s Timing

	Characteristics	Sym	Min	Typ	Max	Units	Test Conditions
1	DCL Clock Width High or Low	t_{DCLW}	100	122	144	ns	
2	Frame Pulse Setup	t_{FSCS}	50			ns	
3	Frame Pulse Hold	t_{FSCH}	50			ns	
4	Serial Input Setup	t_{SIS}	30			ns	
5	Serial Input Hold	t_{SIH}	50			ns	

AC Electrical Characteristics - GCI 2.048Mb/s Timing

	Characteristics	Sym	Min	Typ	Max	Units	Test Conditions
6	Serial Output Delay	t_{SOD}			125	ns	150pF load on CSTo and DSTo

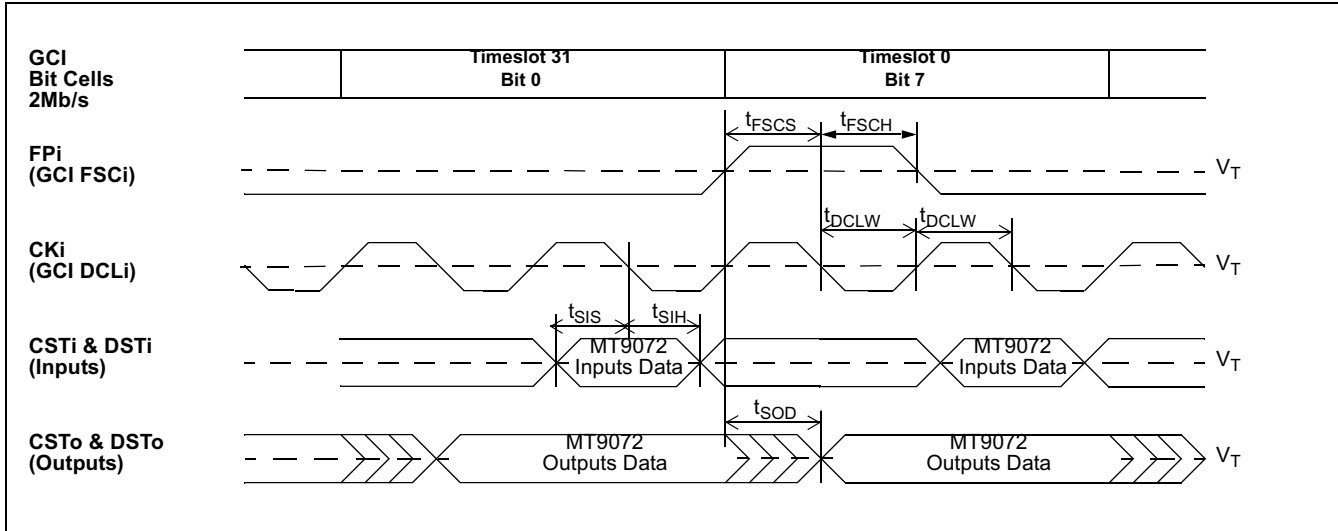

Figure 56 - GCI 2.048Mb/s Timing

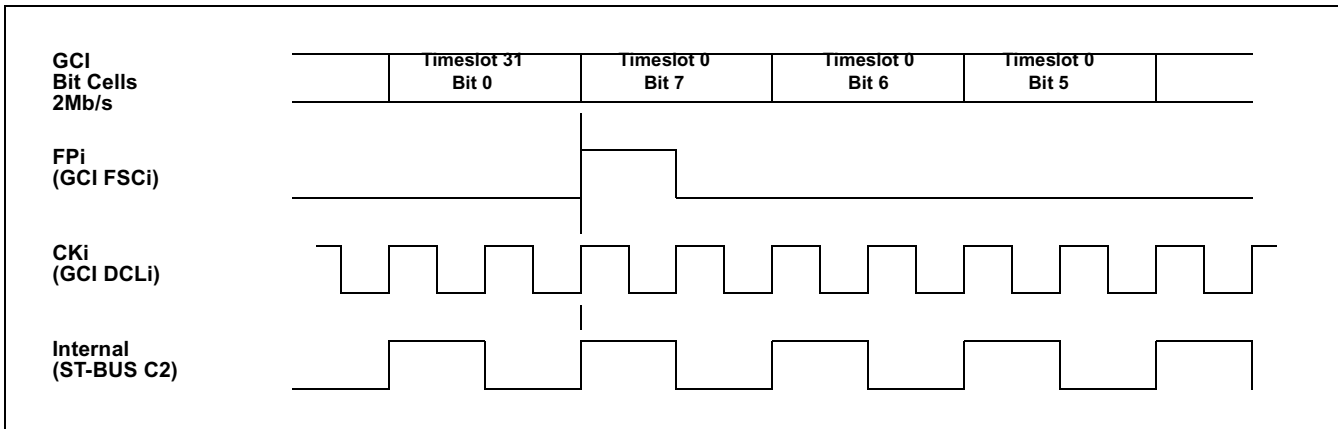

Figure 57 - GCI 2.048Mb/s Functional Timing Diagram

AC Electrical Characteristics - ST-BUS 8.192Mb/s Timing

	Characteristics	Sym	Min	Typ	Max	Units	Test Conditions
1	C16i Clock Width High or Low	t_{C16W}	25	31	35	ns	
2	Frame Pulse Setup	t_{F16S}	10			ns	
3	Frame Pulse Hold	t_{F16H}	20			ns	
4	Serial Input Setup	t_{SIS}	10			ns	

AC Electrical Characteristics - ST-BUS 8.192Mb/s Timing

	Characteristics	Sym	Min	Typ	Max	Units	Test Conditions
5	Serial Input Hold	t_{SIH}	20			ns	
6	Serial Output Delay	t_{SOD}			55	ns	150pF load on CSTo and DSTo

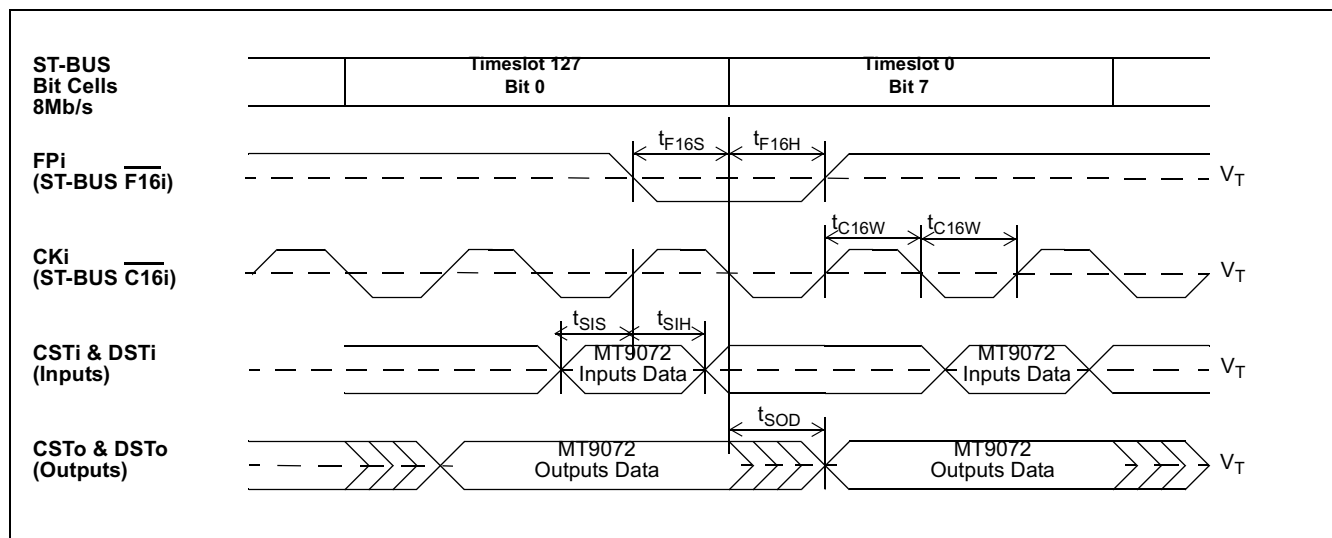

Figure 58 - ST-BUS 8.192Mb/s Timing

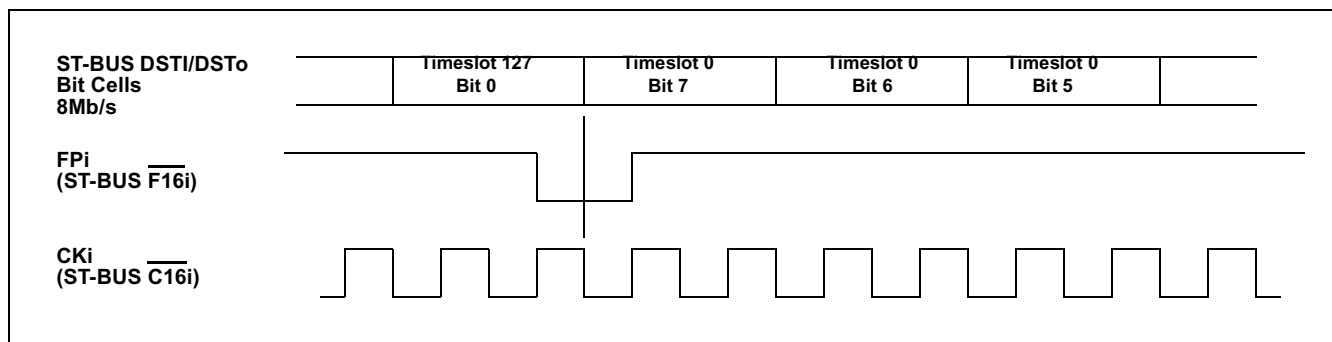

Figure 59 - ST-BUS 8.192Mb/s Functional Timing Diagram for DSTi/DSTo

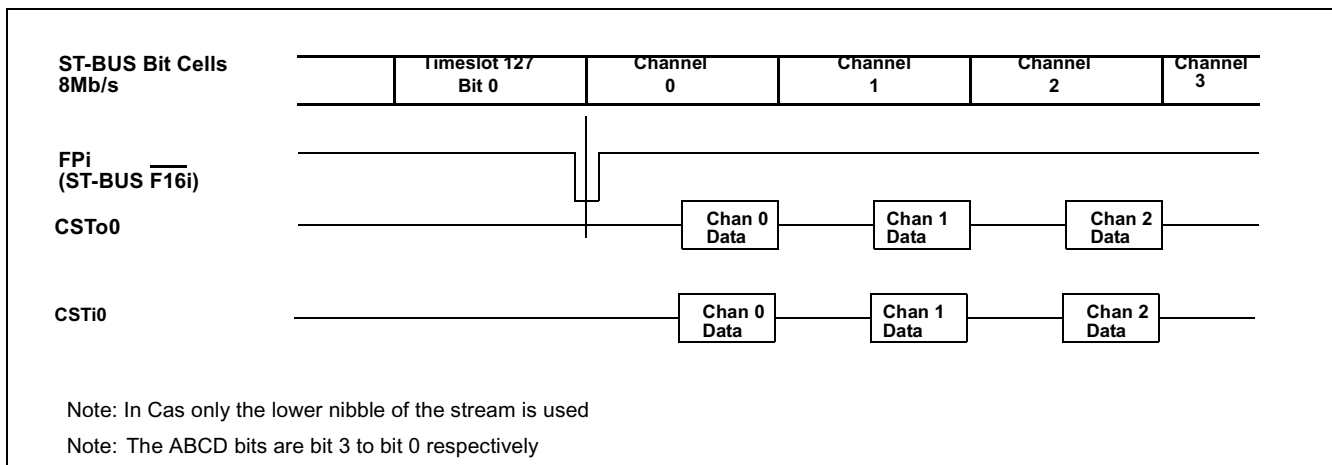

Figure 60 - ST-BUS 8.192Mb/s Functional Timing Diagram for CSTo/CSTi CAS

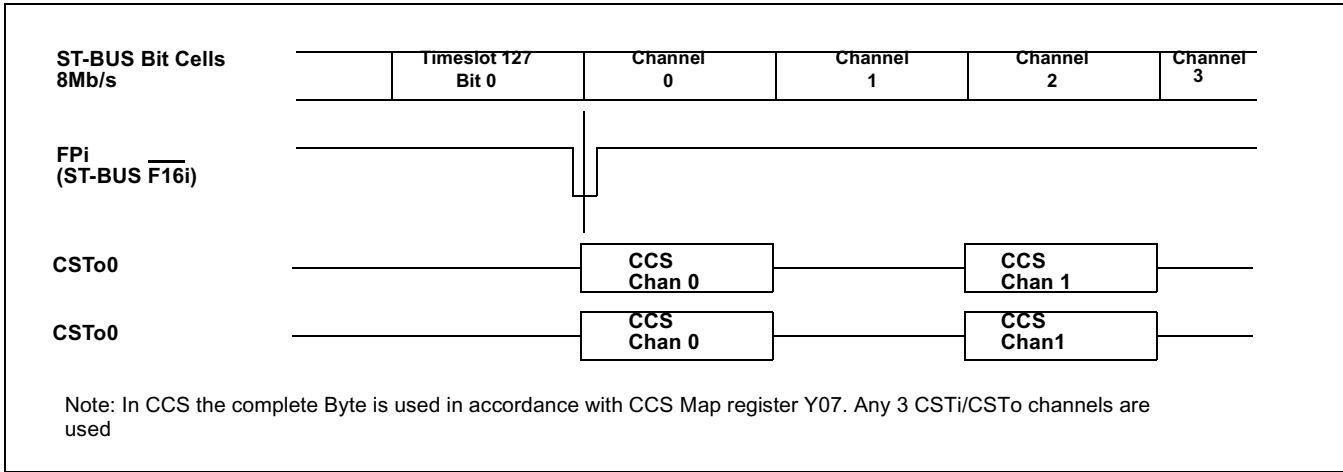

Figure 61 - ST-BUS 8.192Mb/s Functional Timing Diagram for CSTo/CSTi CAS

AC Electrical Characteristics - Receive IMA Timing

	Characteristics	Sym	Min	Typ	Max	Units	Test Conditions
1	RXDLC Clock Width High or Low	t_{C4W}	25		100	ns	
2	Receive Basic Frame Pulse Delay	t_{FD}	50			ns	
4	RXDLC Clock Delay	t_{CD}	50		125	ns	150pF load on CSTo and DSTo

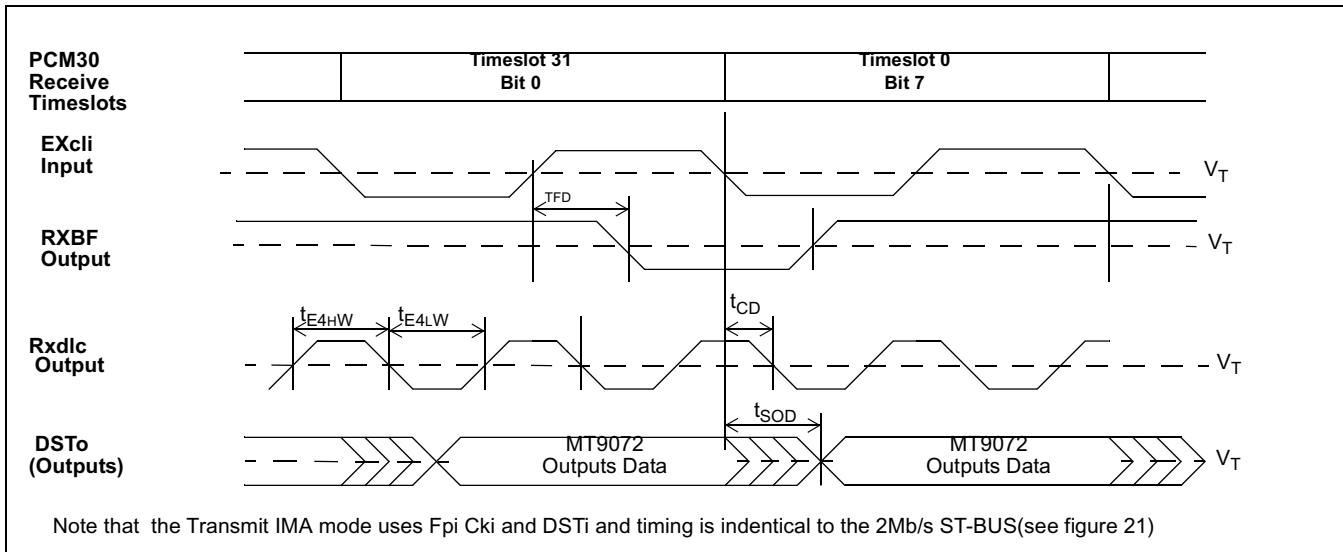

Figure 62 - Receive IMA Timing

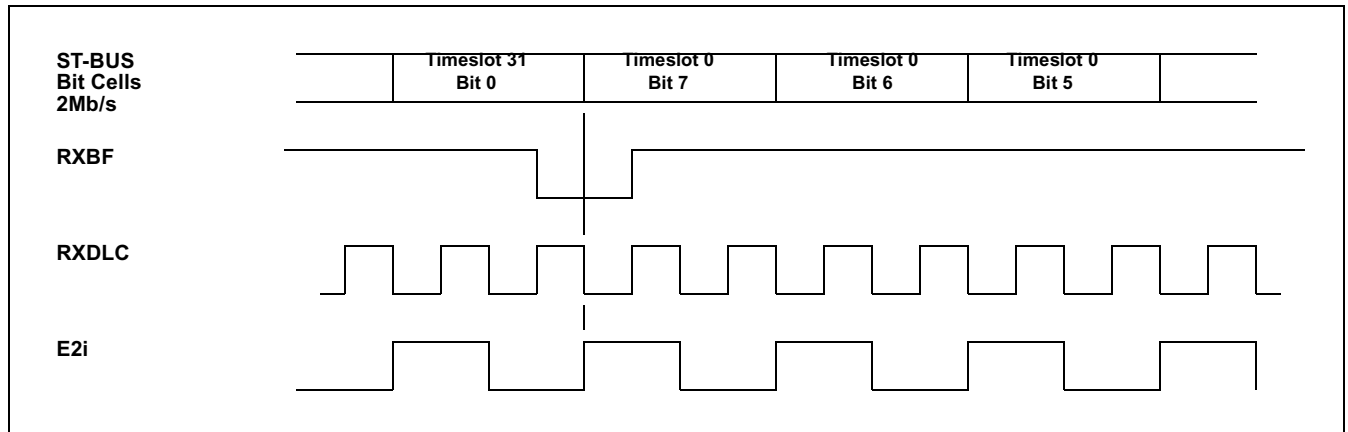

Figure 63 - Receive IMA Functional Timing Diagram

AC Electrical Characteristics - Transmit Multiframe (CRC-4 or CAS) Timing

	Characteristics	Sym	Min	Typ	Max	Units	Test Conditions
1	Transmit Multiframe Setup	t_{MS}	50			ns	

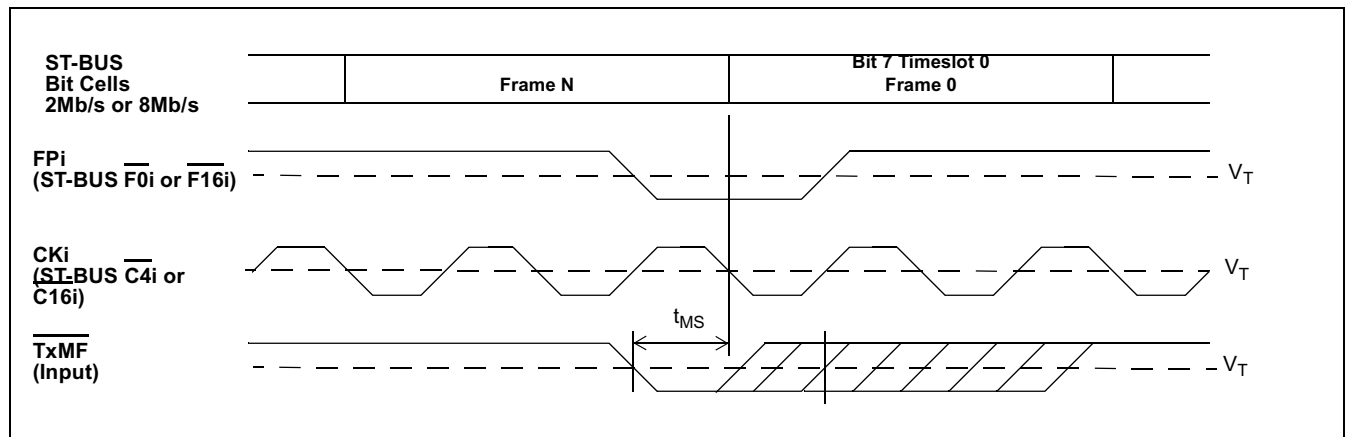

Figure 64 - Transmit Multiframe (CRC-4 or CAS) Timing

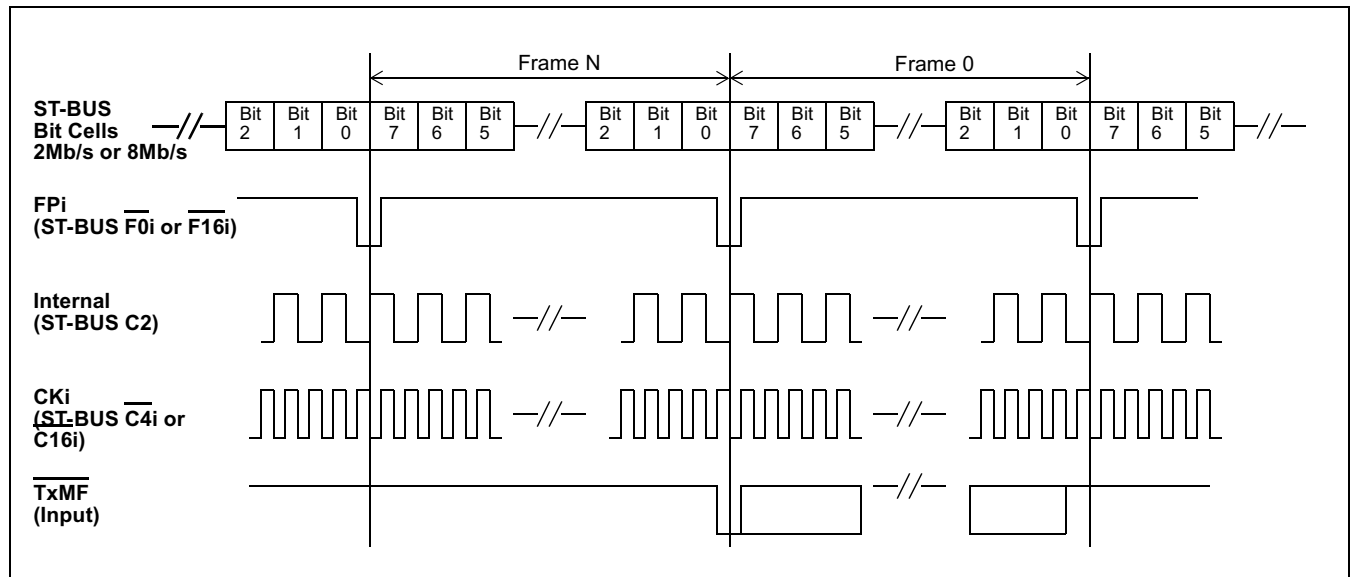

Figure 65 - Transmit Multiframe (CRC-4 or CAS) Functional Timing

AC Electrical Characteristics - Receive Multiframe (CRC-4 or CAS) Timing

	Characteristics	Sym	Min	Typ	Max	Units	Test Conditions
1	Receive Multiframe Output Delay	t_{MOD}			55	ns	150pF load on RxMF

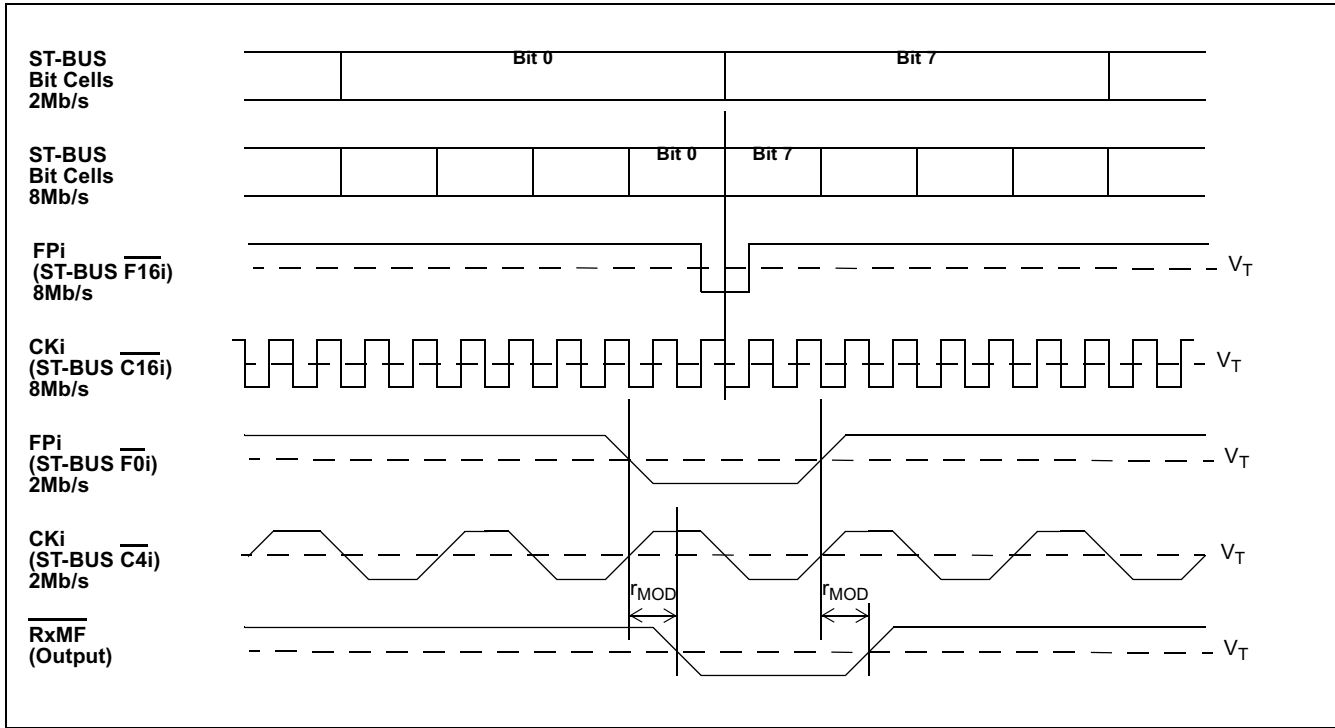

Figure 66 - Receive Multiframe (CRC-4 or CAS) Timing

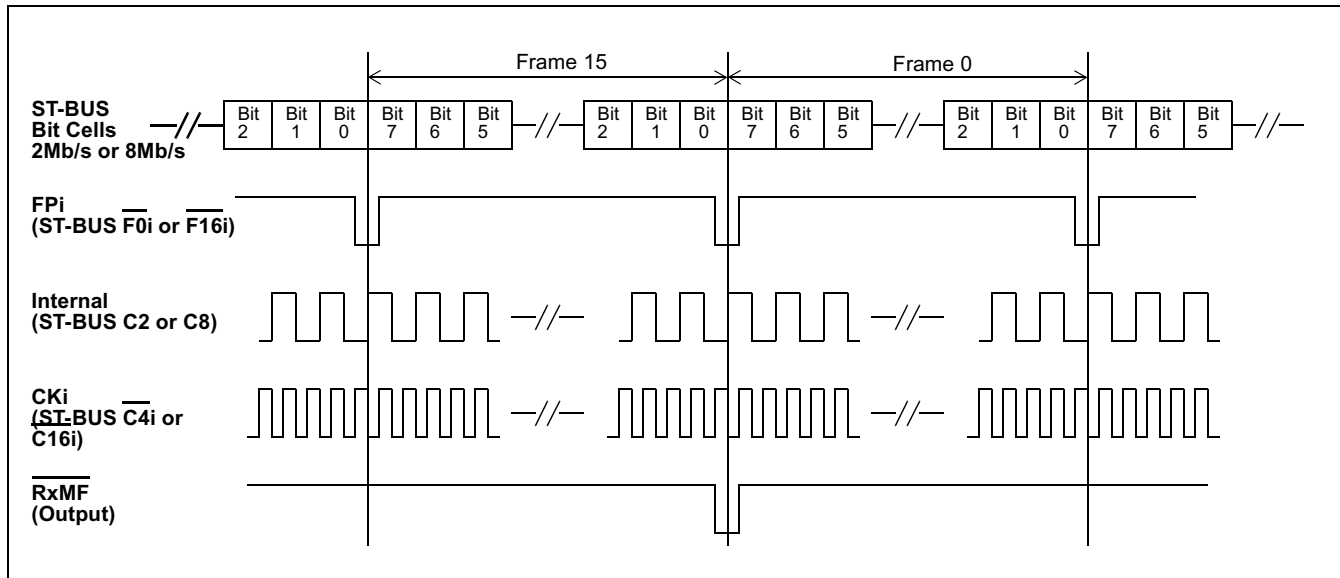

Figure 67 - Receive Multiframe (CRC-4 or CAS) Functional Timing

AC Electrical Characteristics - Receive Multiframe Timing with TX8KEn Set

	Characteristics	Sym	Min	Typ	Max	Units	Test Conditions
1	RXMF Output Delay	t_{TFOD}		20		ns	150pF

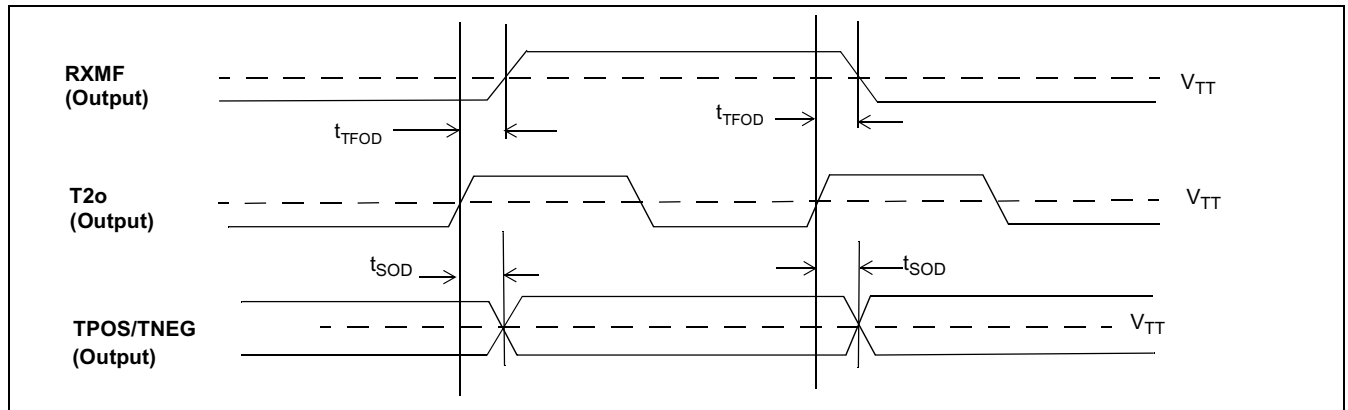

Figure 68 - Receive Multiframe Timing with TX8KEN Set

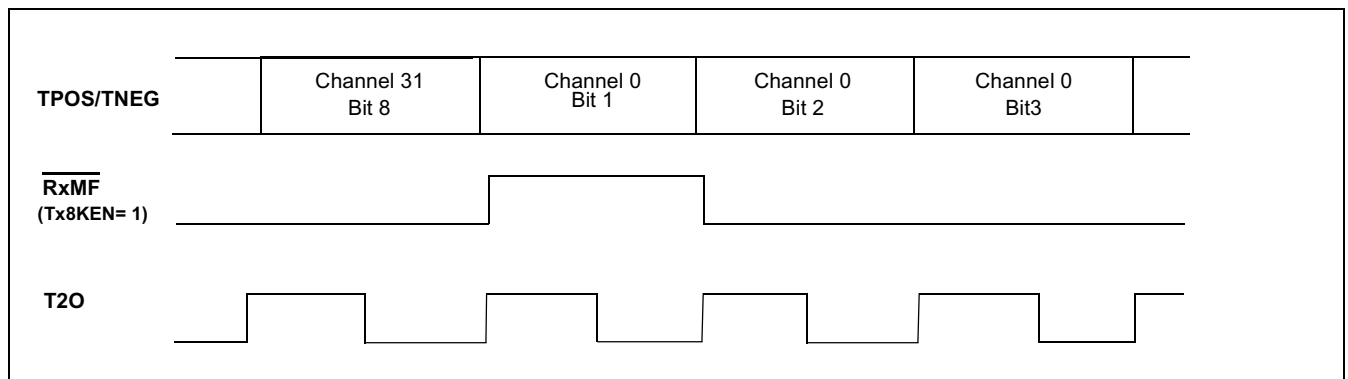

Figure 69 - Receive Multiframe Timing with TX8KEN Set

AC Electrical Characteristics - Transmit Data Link Pin Timing

	Characteristics	Sym	Min	Typ	Max	Units	Test Conditions
1	Clock Delay	t_{CD}			55	ns	150pF load on $\overline{\text{TxDLC}}$
2	Enable Delay	t_{ED}			55	ns	150pF load on $\overline{\text{TxDLC}}$
3	Data Setup	t_{DS}	100			ns	
4	Data Hold	t_{DH}	50			ns	

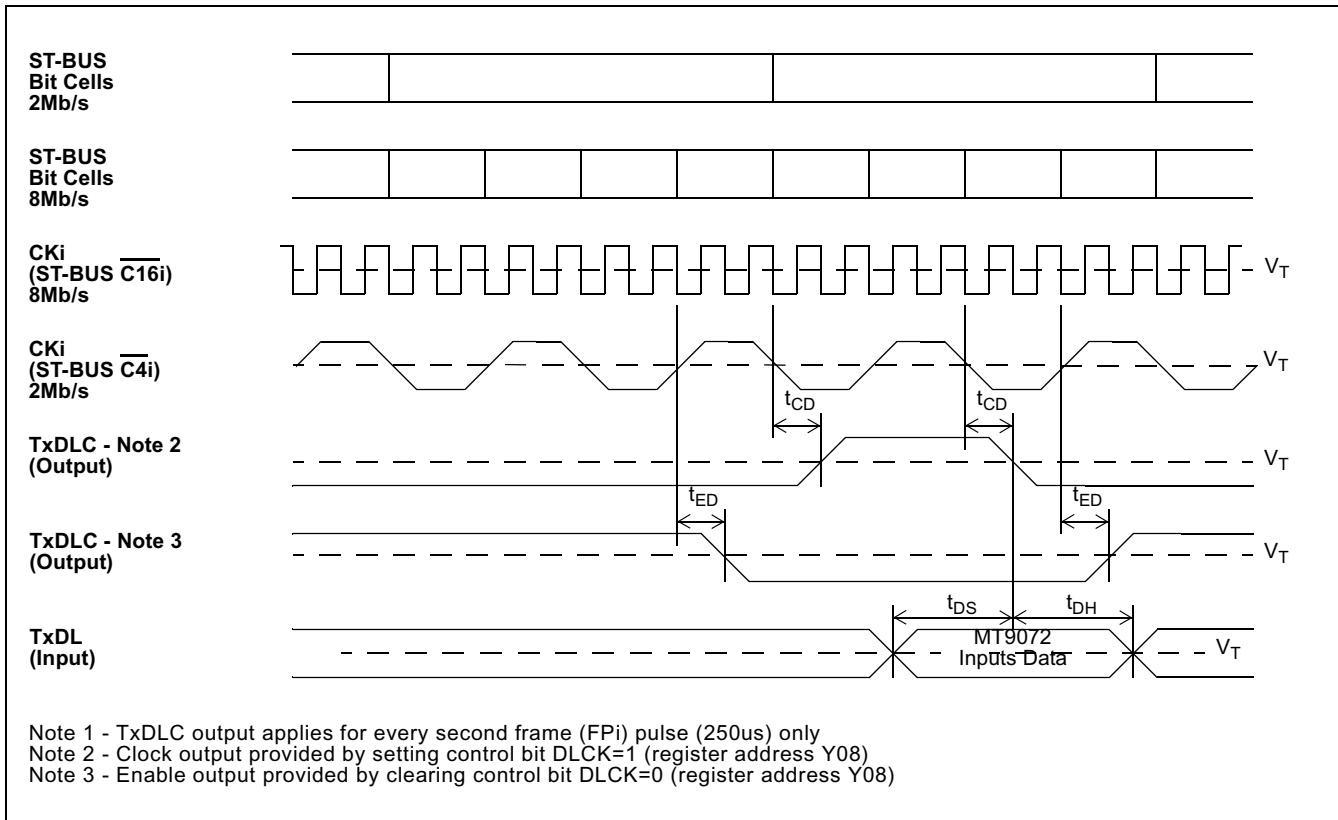

Figure 70 - Transmit Data Link Pin Timing

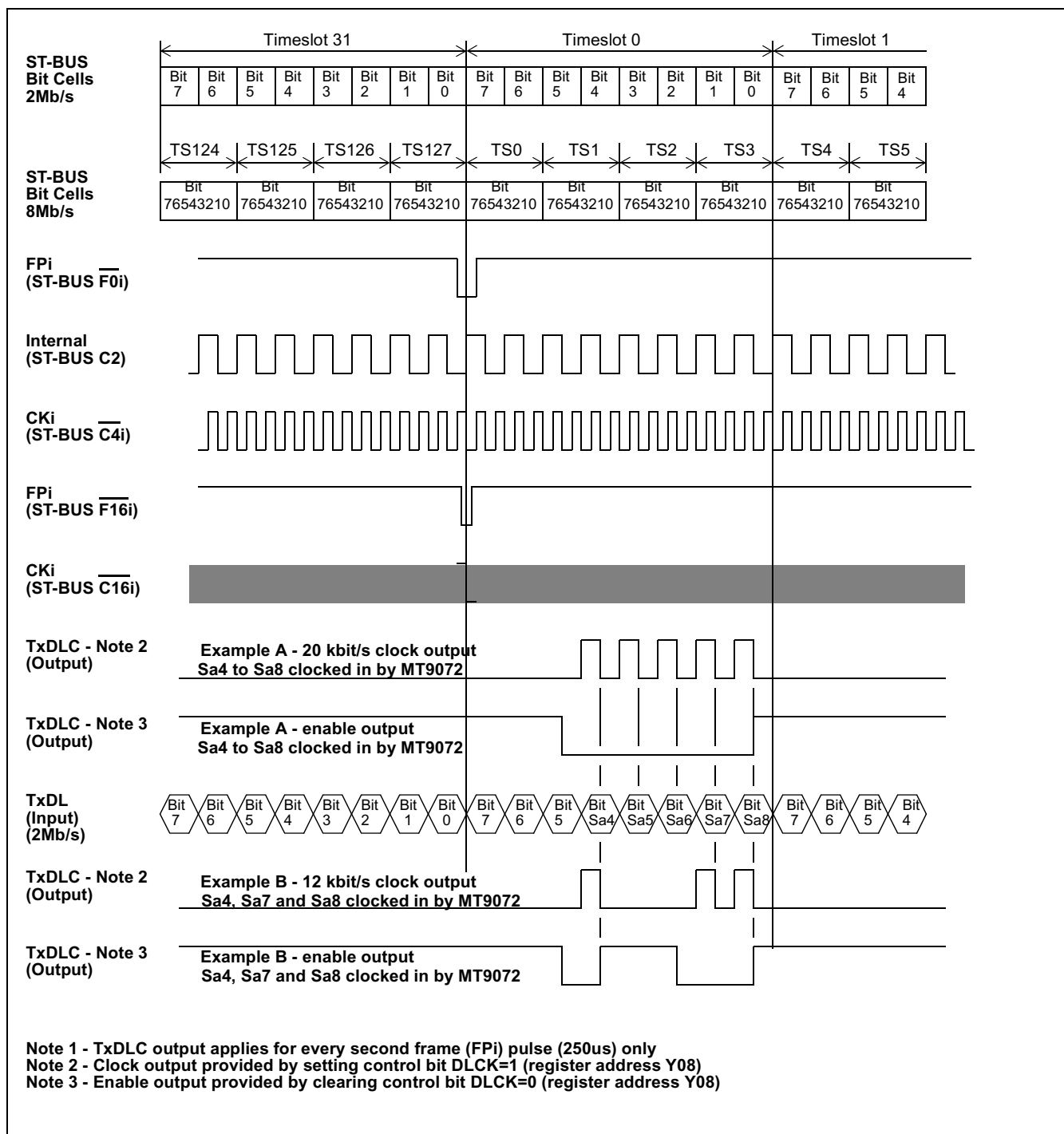

Figure 71 - Transmit Data Link Pin Functional Timing

AC Electrical Characteristics - Receive Basic Frame and E4o Timing

	Characteristics	Sym	Min	Typ	Max	Units	Test Conditions
1	Basic Frame Output Delay	t _{BD}	30		115	ns	150pF load on RxB \overline{F}
2	Clock Delay	t _{CD}			55	ns	150pF load on RxDLC
3	E4o Clock High Width	t _{E4HW}	50		200	ns	150pF load on RxDLC
3	E4o Clock Low Width	t _{E4LW}	25		75	ns	150pF load on RxDLC

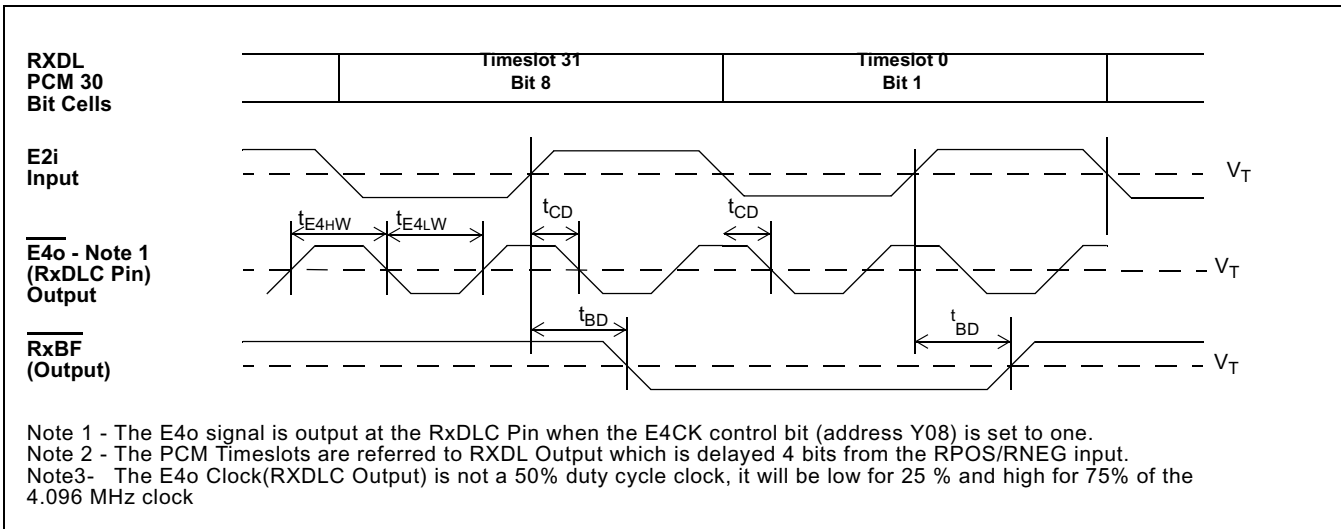

Figure 72 - Receive Basic Frame and E4o Timing

AC Electrical Characteristics - Receive Data Link Timing

	Characteristics	Sym	Min	Typ	Max	Units	Test Conditions
1	Clock Delay	t_{CD}			55	ns	150pF load on RxDLC
2	Enable Delay	t_{ED}			55	ns	150pF load on RxDLC
3	Data Delay Read	t_{DDR}			125	ns	150pF load on RxDL

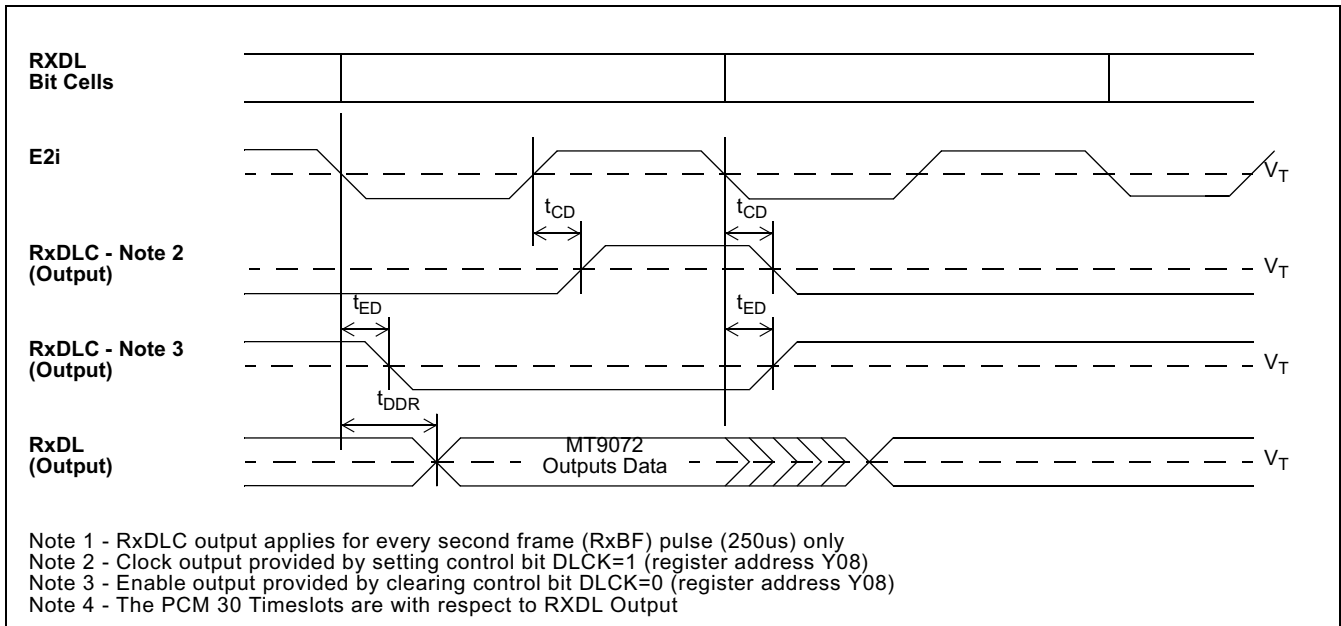

Figure 73 - Receive Data Link Timing

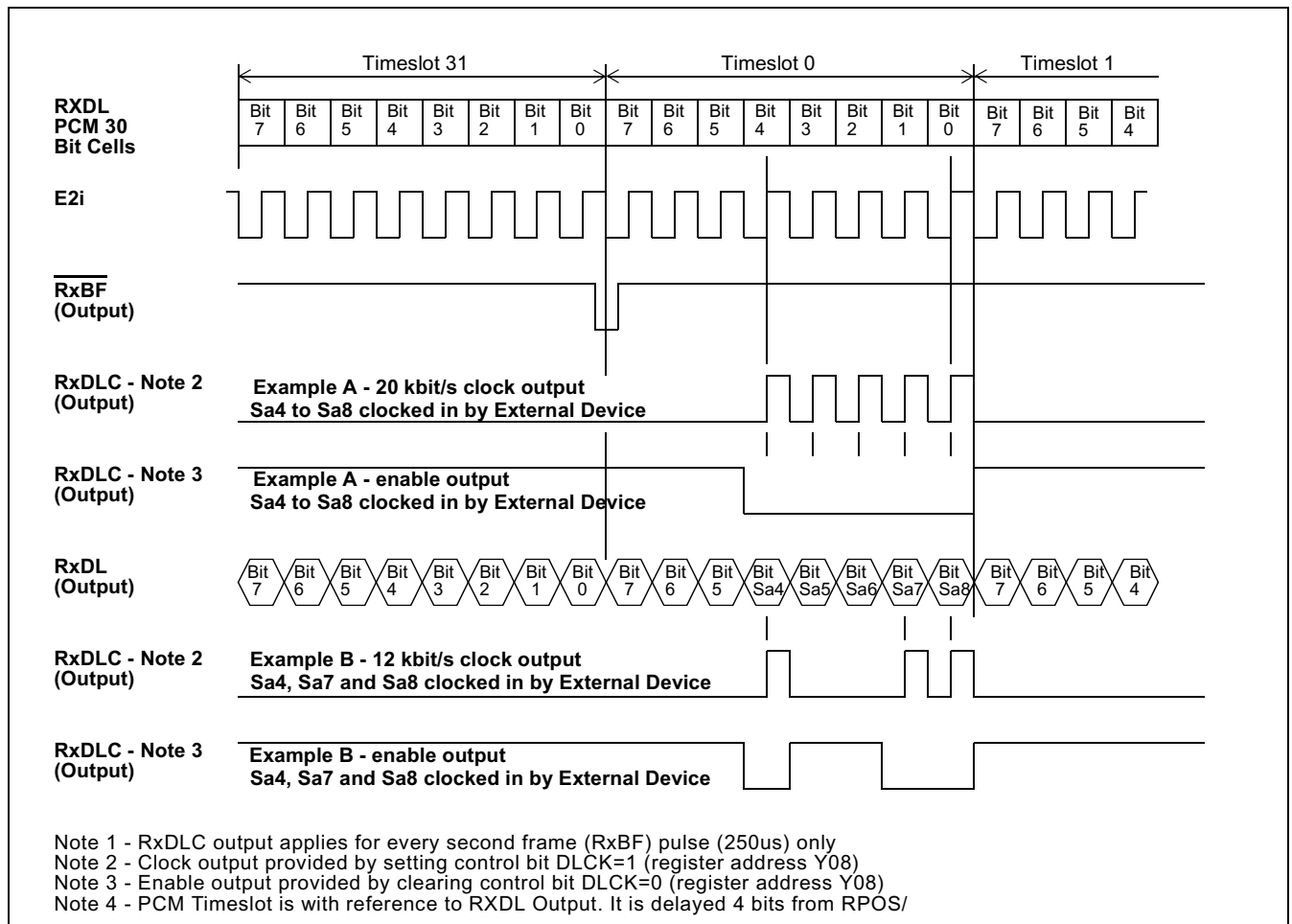

Figure 74 - Receive Data Link Pin Functional Timing

AC Electrical Characteristics - PCM30 Transmit Timing

	Characteristics	Sym	Min	Typ	Max	Units	Test Conditions
1	Transmit Output Clock Delay	t_{CD}			55	ns	150pF load on T2o
2	Transmit Output Delay	t_{TOD}			55	ns	150pF load on TPOS and TNEG

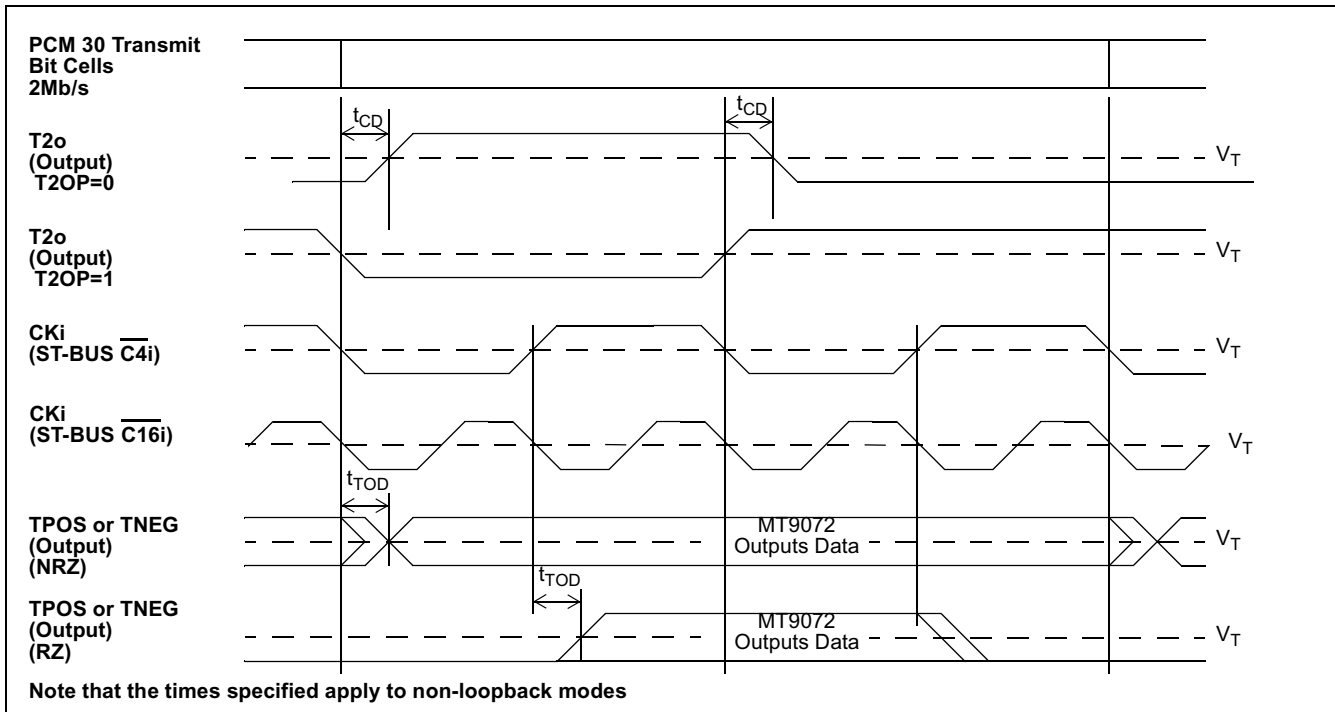

Figure 75 - PCM 30 Transmit Timing

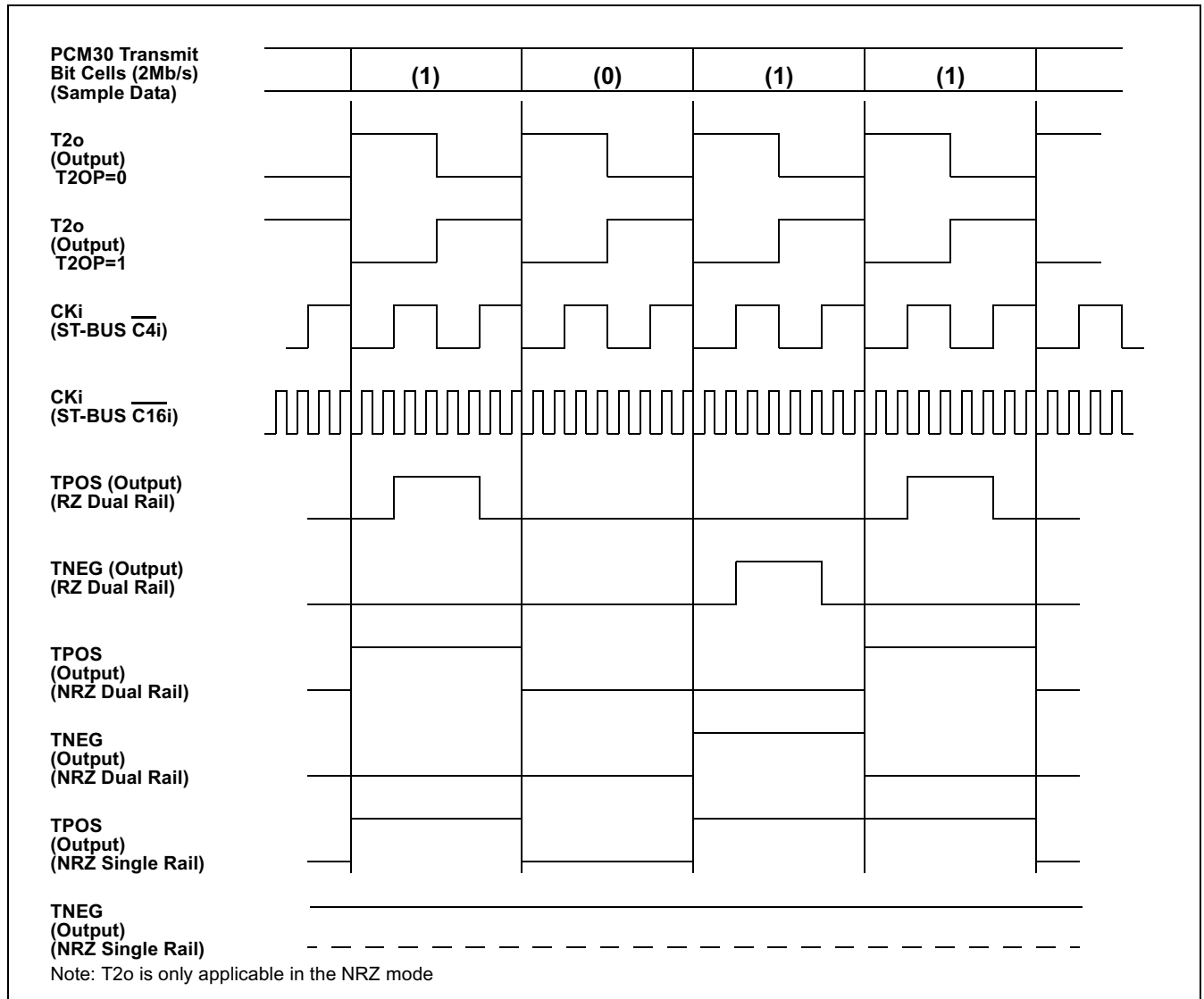

Figure 76 - PCM30 Transmit Functional Timing

AC Electrical Characteristics - PCM30 Receive Timing

	Characteristics	Sym	Min	Typ	Max	Units	Test Conditions
1	Receive Setup	t_{RS}	50			ns	
2	Receive Hold	t_{RH}	50			ns	

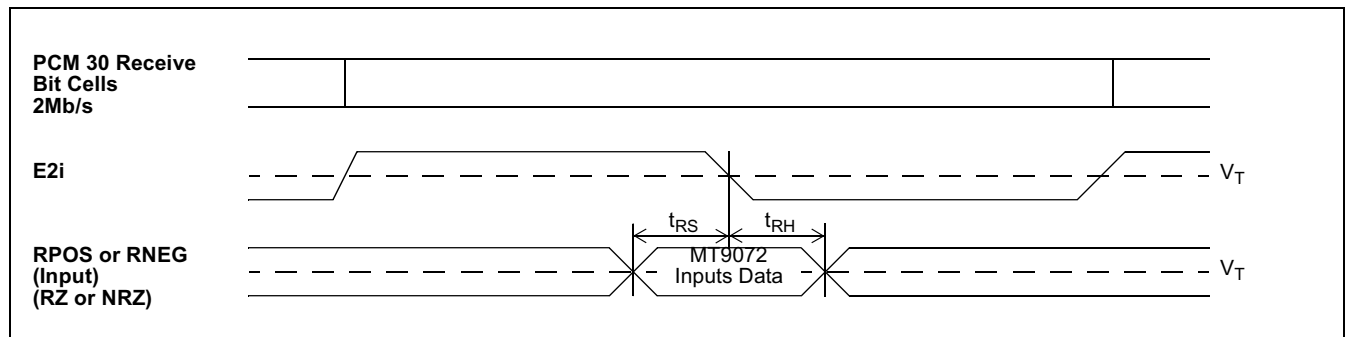

Figure 77 - PCM 30 Receive Timing

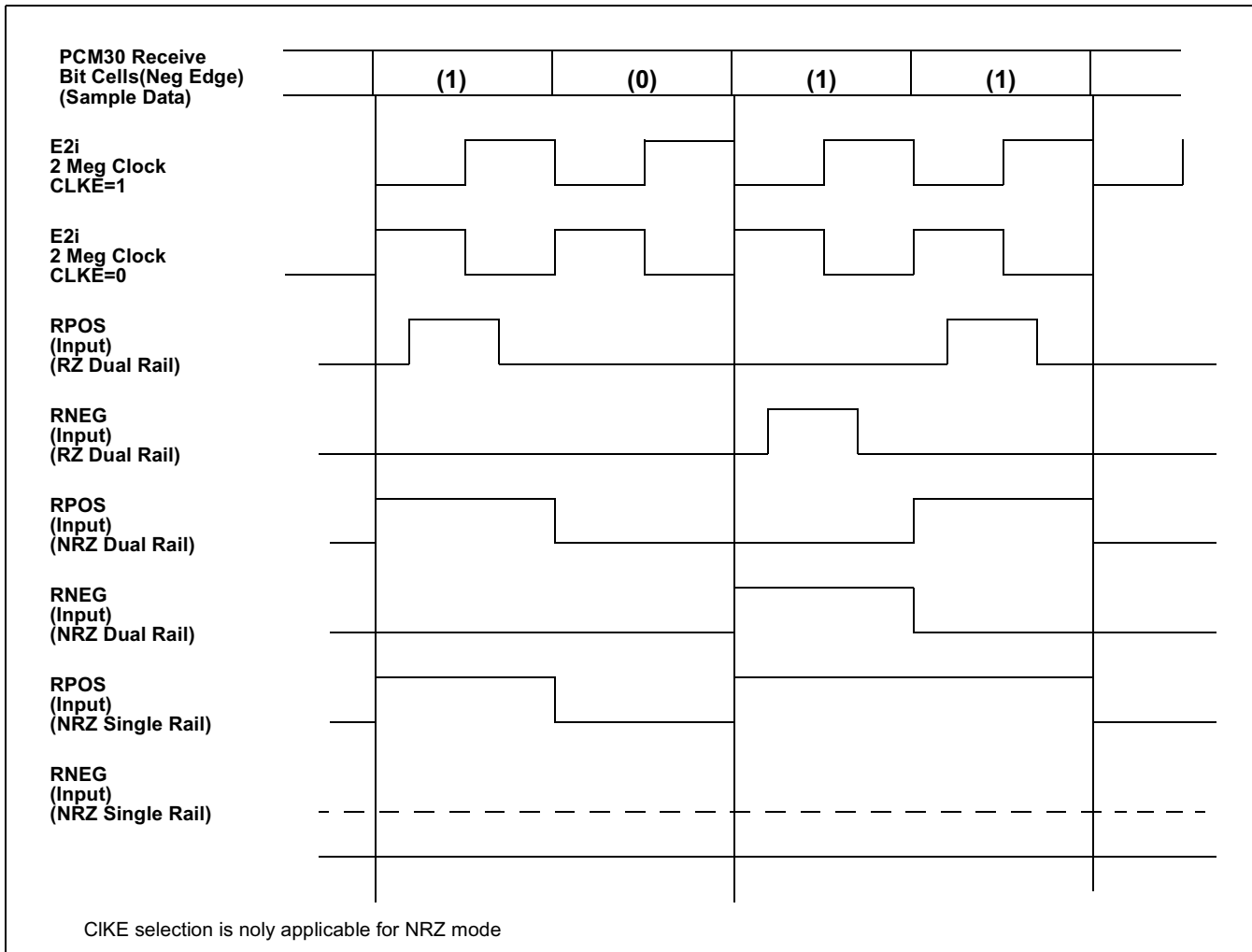

Figure 78 - PCM30 Receive Functional Timing

17.1 AC Electrical Characteristics - PCM30 and ST-BUS Frame Format

In both the transmit and receive directions, PCM30 LSB maps to ST-BUS LSB.

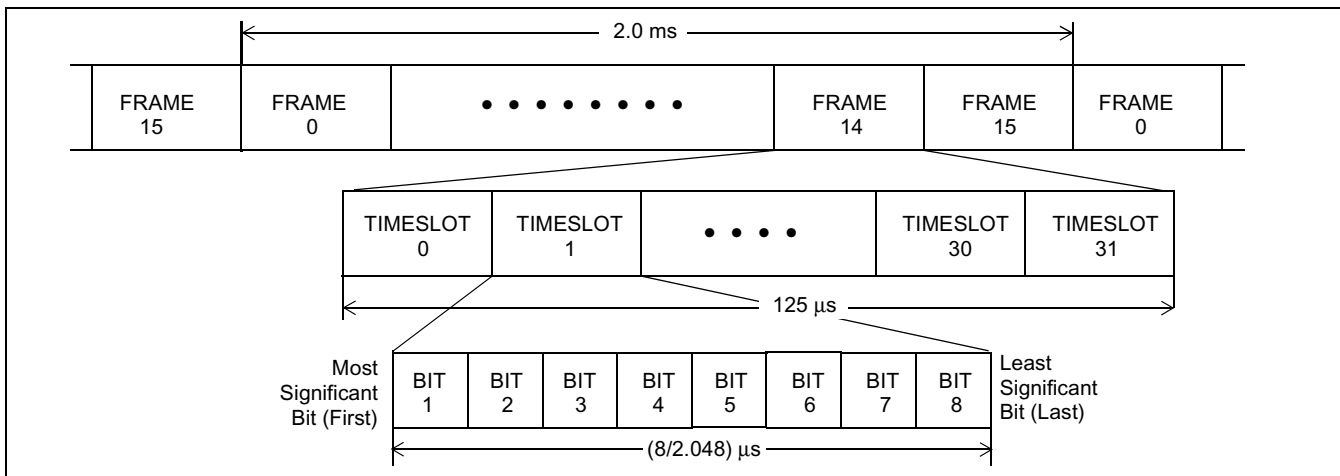

Figure 79 - PCM 30 Format

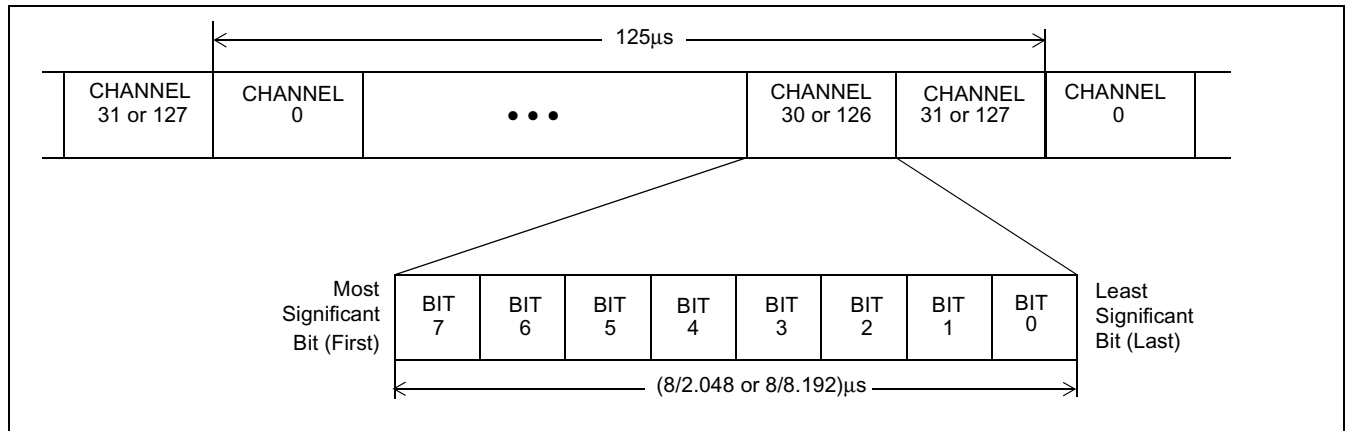

Figure 80 - ST-BUS Format

18.0 Applicable Specifications

Standard	Title
T1.102-1993	Digital Heirarchy_Electrical Interfaces
T1.231-1993	Layer 1 In-Service Digital Transmission Performance Monitoring
T1.403-1995	Network to Customer Installation Metallic Interfaces
T1.408-1990	ISDN Primary Rate- Customer Installation Metallic Interfaces
TR 62411-1990	Accunet T1.5 Service Description and Interface Specification
TA-TSY-000278 Issue1, 1985	Digital Data Systems(DDS)- T1 Digital Multiplexor(T1DM) Requirements
G.711	Pulse Code Modulation(PCM) of Voice Frequencies

Table 208 - Applicable Telecommunications Specifications.

Package Outlines

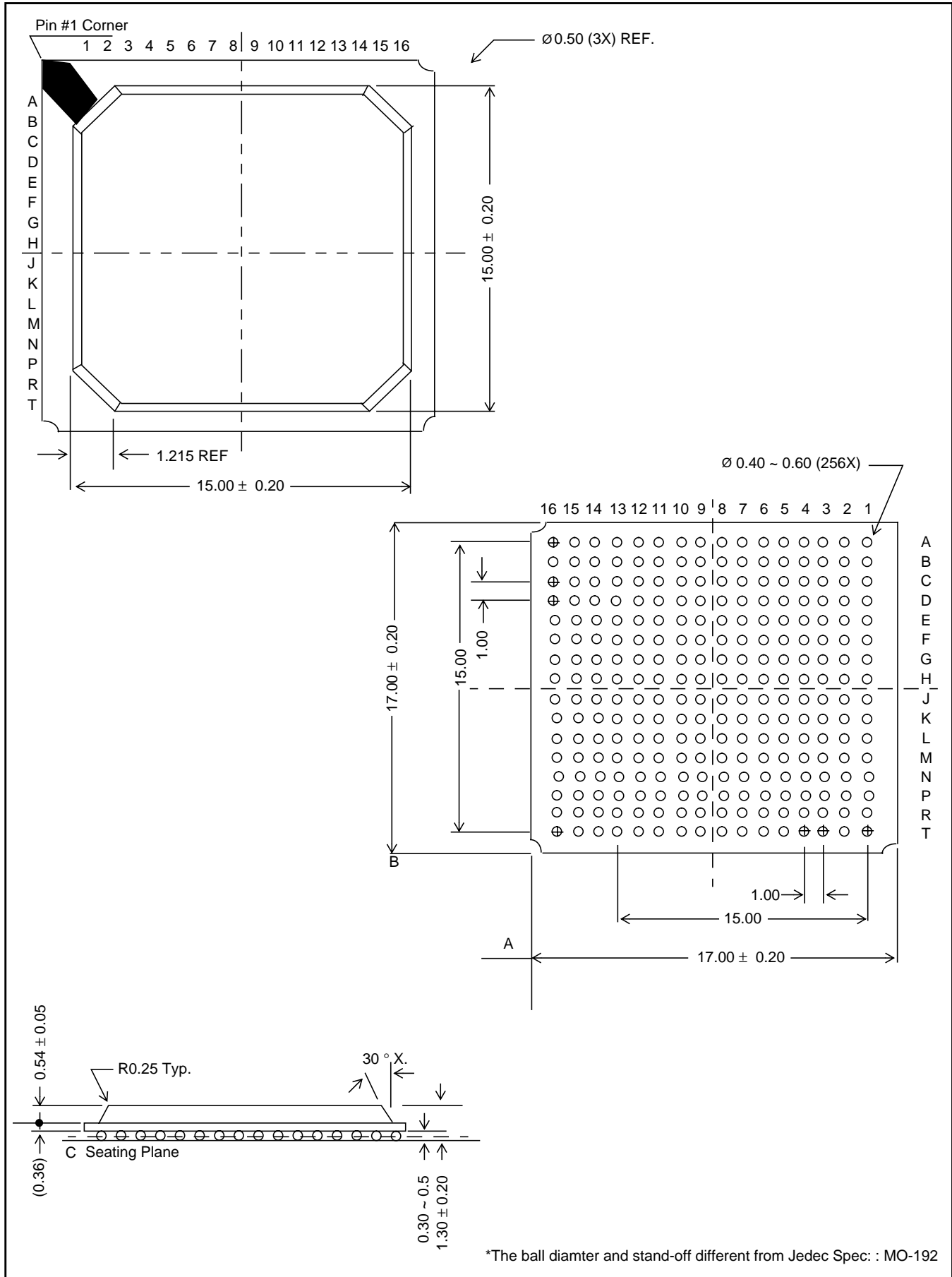

LPGA - 256

Package Outlines

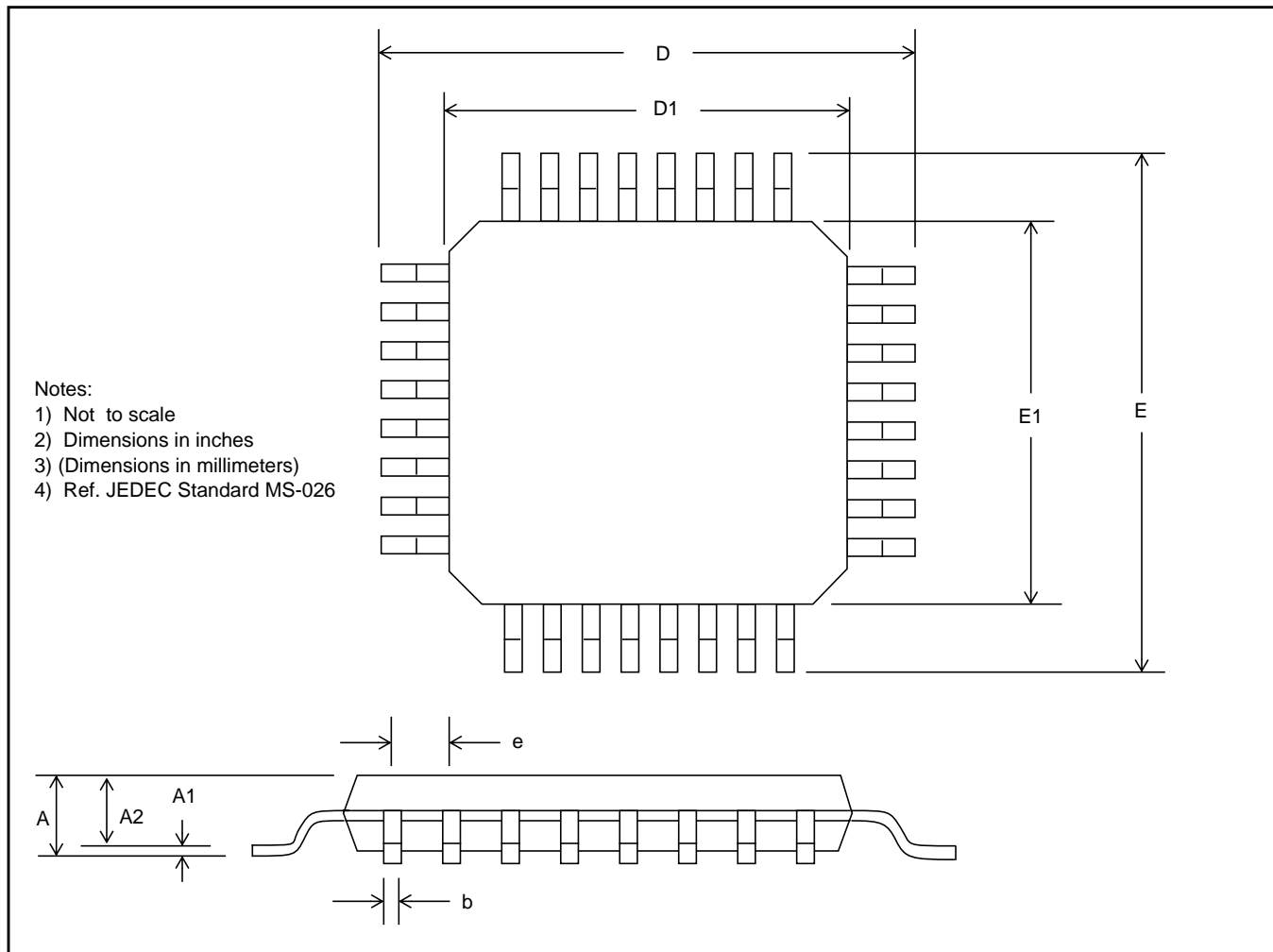

Dim	80-Pin		100-Pin		128-Pin		208-Pin		256-Pin	
	Min	Max	Min	Max	Min	Max	Min	Max	Min	Max
A	-	0.063 (1.60)	-	0.063 (1.60)	-	0.063 (1.60)	-	0.063 (1.60)	-	0.063 (1.60)
A1	0.002 (0.05)	0.006 (0.15)	0.002 (0.05)	0.006 (0.15)	0.002 (0.05)	0.006 (0.15)	0.002 (0.05)	0.006 (0.15)	0.002 (0.05)	0.006 (0.15)
A2	0.053 (1.35)	0.057 (1.45)	0.053 (1.35)	0.057 (1.45)	0.053 (1.35)	0.057 (1.45)	0.053 (1.35)	0.057 (1.45)	0.053 (1.35)	0.057 (1.45)
b	0.009 (0.22)	0.015 (0.38)	0.001 (0.17)	0.011 (0.27)	0.001 (0.17)	0.011 (0.27)	0.001 (0.17)	0.011 (0.27)	0.005 (0.13)	0.009 (0.23)
D	0.630 (16.00 BSC)		0.630 (16.00 BSC)		0.866 (22.00 BSC)		1.181 (30.00 BSC)		1.181 (30.00 BSC)	
D1	0.551 (14.00 BSC)		0.551 (14.00 BSC)		0.787 (20.00 BSC)		1.102 (28.00 BSC)		1.102 (28.00 BSC)	
e	0.025 (0.65 BSC)		0.020 (0.50 BSC)		0.020 (0.50 BSC)		0.020 (0.50 BSC)		0.016 (0.40 BSC)	
E	0.630 (16.00 BSC)		0.630 (16.00 BSC)		0.630 (16.00 BSC)		1.181 (30.00 BSC)		1.181 (30.0 BSC)	
E1	0.551 (14.00 BSC)		0.551 (14.00 BSC)		0.551 (14.00 BSC)		1.102 (28.00 BSC)		1.102 (28.00 BSC)	

LQFP - B Suffix

Package Outlines

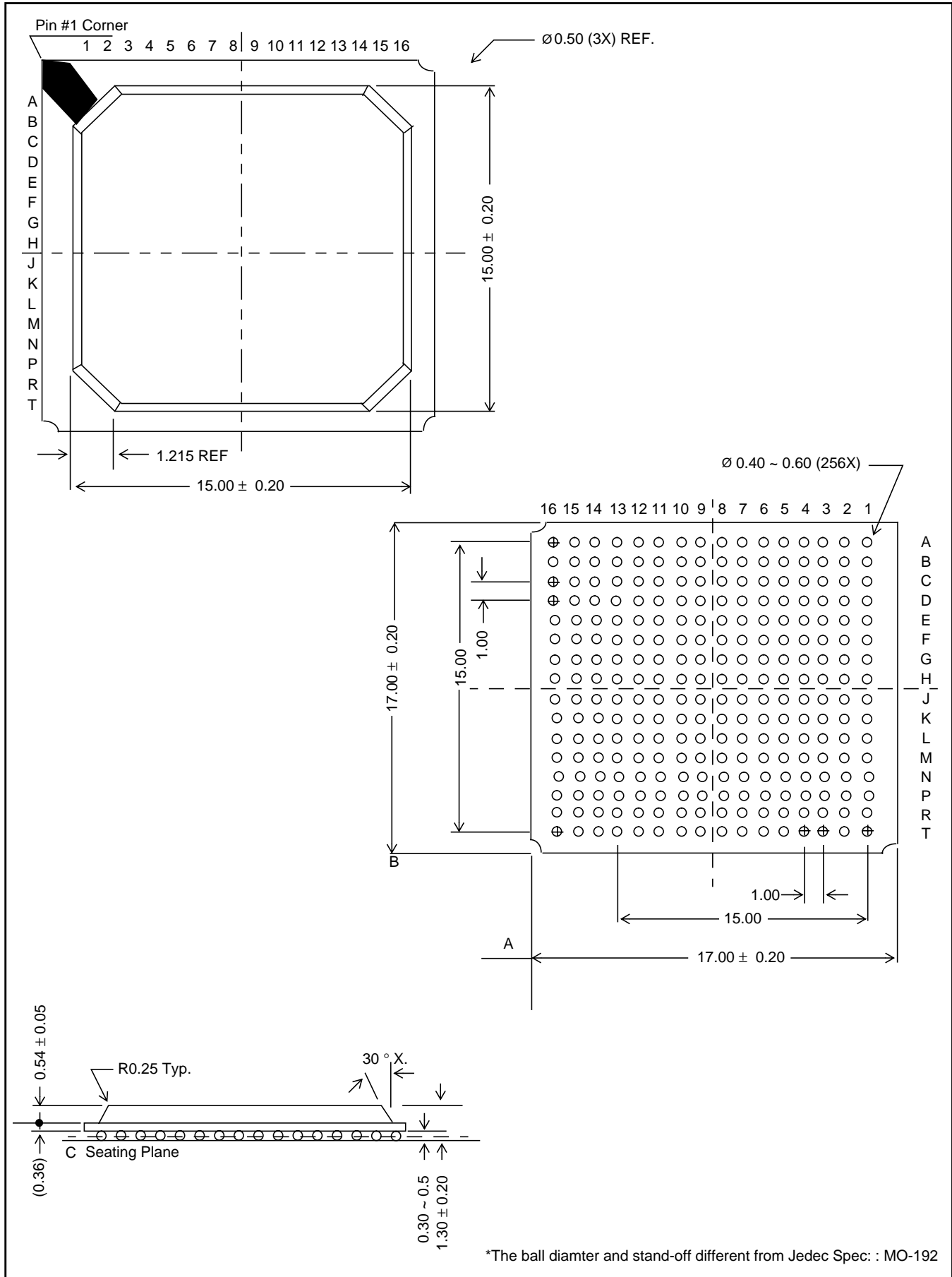

LPGA - 256

Package Outlines

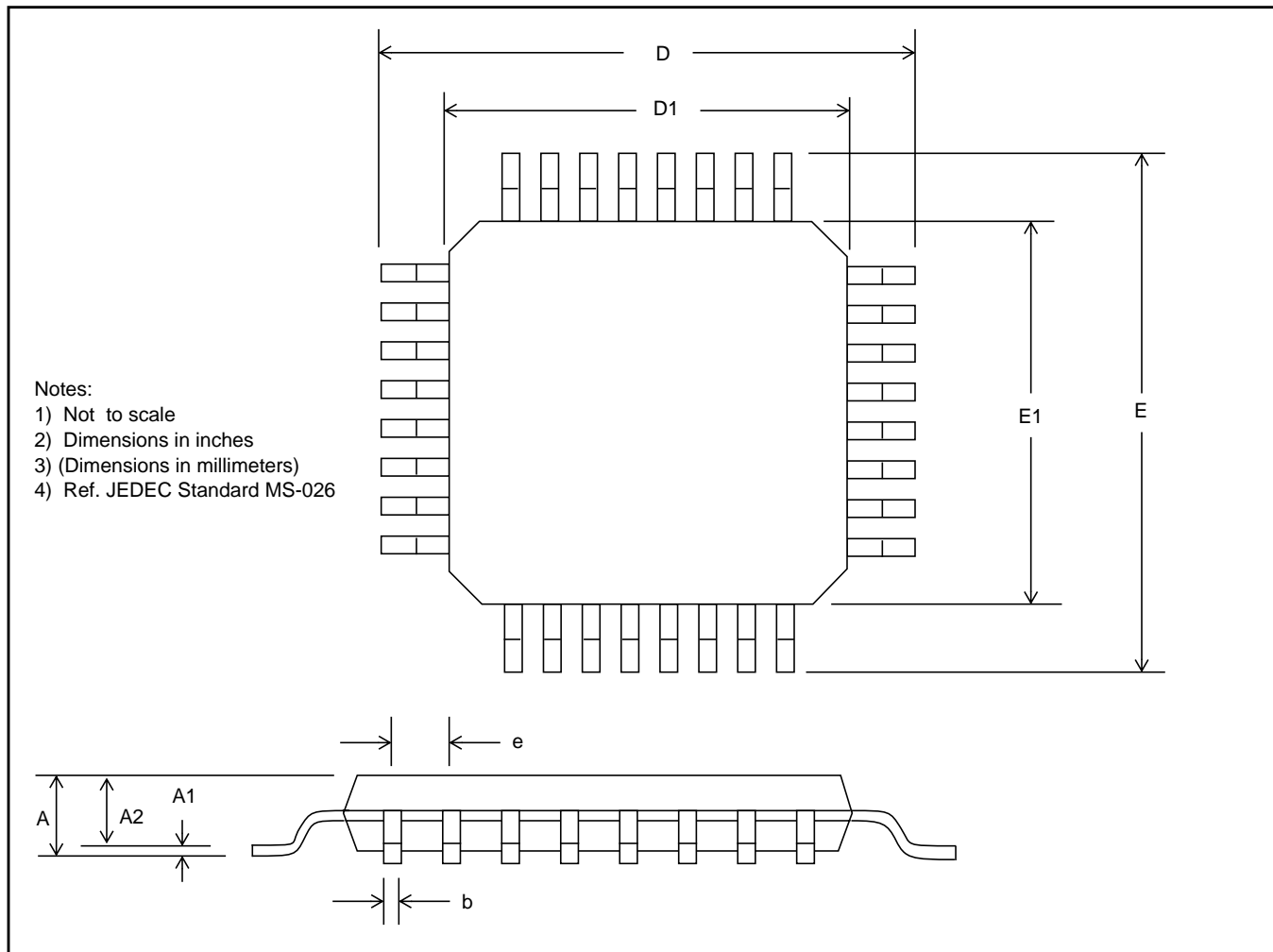

Dim	80-Pin		100-Pin		128-Pin		208-Pin		256-Pin	
	Min	Max	Min	Max	Min	Max	Min	Max	Min	Max
A	-	0.063 (1.60)	-	0.063 (1.60)	-	0.063 (1.60)	-	0.063 (1.60)	-	0.063 (1.60)
A1	0.002 (0.05)	0.006 (0.15)	0.002 (0.05)	0.006 (0.15)	0.002 (0.05)	0.006 (0.15)	0.002 (0.05)	0.006 (0.15)	0.002 (0.05)	0.006 (0.15)
A2	0.053 (1.35)	0.057 (1.45)	0.053 (1.35)	0.057 (1.45)	0.053 (1.35)	0.057 (1.45)	0.053 (1.35)	0.057 (1.45)	0.053 (1.35)	0.057 (1.45)
b	0.009 (0.22)	0.015 (0.38)	0.001 (0.17)	0.011 (0.27)	0.001 (0.17)	0.011 (0.27)	0.001 (0.17)	0.011 (0.27)	0.005 (0.13)	0.009 (0.23)
D	0.630 (16.00 BSC)		0.630 (16.00 BSC)		0.866 (22.00 BSC)		1.181 (30.00 BSC)		1.181 (30.00 BSC)	
D1	0.551 (14.00 BSC)		0.551 (14.00 BSC)		0.787 (20.00 BSC)		1.102 (28.00 BSC)		1.102 (28.00 BSC)	
e	0.025 (0.65 BSC)		0.020 (0.50 BSC)		0.020 (0.50 BSC)		0.020 (0.50 BSC)		0.016 (0.40 BSC)	
E	0.630 (16.00 BSC)		0.630 (16.00 BSC)		0.630 (16.00 BSC)		1.181 (30.00 BSC)		1.181 (30.0 BSC)	
E1	0.551 (14.00 BSC)		0.551 (14.00 BSC)		0.551 (14.00 BSC)		1.102 (28.00 BSC)		1.102 (28.00 BSC)	

LQFP - B Suffix



<http://www.zarlink.com>

World Headquarters - Canada

Tel: +1 (613) 592 0200

Fax: +1 (613) 592 1010

North America - West Coast

Tel: (858) 675-3400

Fax: (858) 675-3450

North America - East Coast

Tel: (978) 322-4800

Fax: (978) 322-4888

Asia/Pacific

Tel: +65 333 6193

Fax: +65 333 6192

**Europe, Middle East,
and Africa (EMEA)**

Tel: +44 (0) 1793 518528

Fax: +44 (0) 1793 518581

Information relating to products and services furnished herein by Zarlink Semiconductor Inc. trading as Zarlink Semiconductor or its subsidiaries (collectively "Zarlink") is believed to be reliable. However, Zarlink assumes no liability for errors that may appear in this publication, or for liability otherwise arising from the application or use of any such information, product or service or for any infringement of patents or other intellectual property rights owned by third parties which may result from such application or use. Neither the supply of such information or purchase of product or service conveys any license, either express or implied, under patents or other intellectual property rights owned by Zarlink or licensed from third parties by Zarlink, whatsoever. Purchasers of products are also hereby notified that the use of product in certain ways or in combination with Zarlink, or non-Zarlink furnished goods or services may infringe patents or other intellectual property rights owned by Zarlink.

This publication is issued to provide information only and (unless agreed by Zarlink in writing) may not be used, applied or reproduced for any purpose nor form part of any order or contract nor to be regarded as a representation relating to the products or services concerned. The products, their specifications, services and other information appearing in this publication are subject to change by Zarlink without notice. No warranty or guarantee express or implied is made regarding the capability, performance or suitability of any product or service. Information concerning possible methods of use is provided as a guide only and does not constitute any guarantee that such methods of use will be satisfactory in a specific piece of equipment. It is the user's responsibility to fully determine the performance and suitability of any equipment using such information and to ensure that any publication or data used is up to date and has not been superseded. Manufacturing does not necessarily include testing of all functions or parameters. These products are not suitable for use in any medical products whose failure to perform may result in significant injury or death to the user. All products and materials are sold and services provided subject to Zarlink Semiconductor's conditions of sale which are available on request.

Purchase of Zarlink's I²C components conveys a licence under the Philips I²C Patent rights to use these components in an I²C System, provided that the system conforms to the I²C Standard Specification as defined by Philips

Zarlink and the Zarlink Semiconductor logo are trademarks of Zarlink Semiconductor Inc.
Copyright 2001, Zarlink Semiconductor Inc. All rights reserved.

TECHNICAL DOCUMENTATION - NOT FOR RESALE