

2SA1124

Silicon PNP epitaxial planer type

For low-frequency high breakdown voltage amplification
Complementary to 2SC2632

■ Features

- Satisfactory forward current transfer ratio h_{FE} collector current I_C characteristics.
- High collector to emitter voltage V_{CEO} .
- Small collector output capacitance C_{ob} .
- Makes up a complementary pair with 2SC2632, which is optimum for the pre-driver stage of a 40 to 60W output amplifier.

■ Absolute Maximum Ratings (Ta=25°C)

Parameter	Symbol	Ratings	Unit
Collector to base voltage	V_{CBO}	-150	V
Collector to emitter voltage	V_{CEO}	-150	V
Emitter to base voltage	V_{EBO}	-5	V
Peak collector current	I_{CP}	-100	mA
Collector current	I_C	-50	mA
Collector power dissipation	P_C	1	W
Junction temperature	T_j	150	°C
Storage temperature	T_{stg}	-55 ~ +150	°C

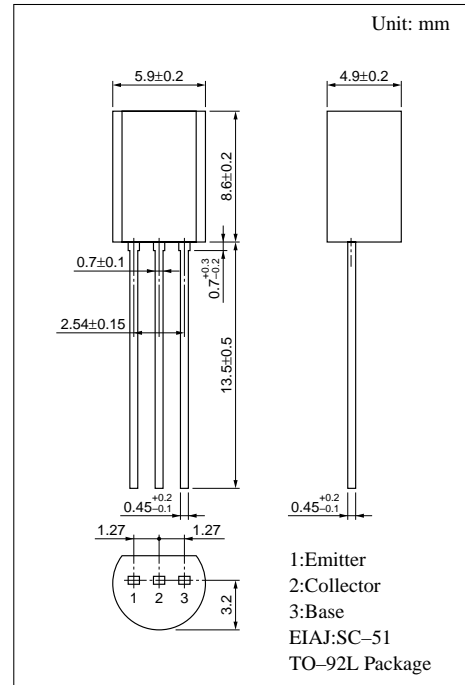

■ Electrical Characteristics (Ta=25°C)

Parameter	Symbol	Conditions	min	typ	max	Unit
Collector cutoff current	I_{CBO}	$V_{CB} = -100V, I_E = 0$			-1	μA
Collector to emitter voltage	V_{CEO}	$I_C = -0.1mA, I_B = 0$	-150			V
Emitter to base voltage	V_{EBO}	$I_E = -10\mu A, I_C = 0$	-5			V
Forward current transfer ratio	h_{FE}^*	$V_{CE} = -5V, I_C = -10mA$	130		450	
Collector to emitter saturation voltage	$V_{CE(sat)}$	$I_C = -30mA, I_B = -3mA$			-1	V
Transition frequency	f_T	$V_{CB} = -10V, I_E = 10mA, f = 200MHz$		200		MHz
Collector output capacitance	C_{ob}	$V_{CE} = -10V, I_E = 0, f = 1MHz$			5	pF
Noise voltage	NV	$V_{CE} = -10V, I_C = -1mA, G_V = 80dB$ $R_g = 100k\Omega, Function = FLAT$		150	300	mV

* h_{FE} Rank classification

Rank	R	S	T
h_{FE}	130 ~ 220	185 ~ 330	260 ~ 450

