

# Surface-mount 4-circuit Low-side Switch Array SPF5001

## Features

- DMOS 4ch output
- Allows ON/OFF using C-MOS logic level
- Built-in overcurrent, overvoltage and thermal protection circuits

## Absolute Maximum Ratings

(Ta = 25°C)

Parameter	Symbol	Ratings	Unit	Conditions
Power supply voltage	V <sub>B</sub>	40	V	
Output terminal voltage	V <sub>OUT</sub>	40	V	
Input terminal voltage	V <sub>IN</sub>	-0.5 to +7.5	V	
Output current	I <sub>O</sub>	1.8	A	
Power Dissipation	P <sub>D</sub>	2	W	
Storage temperature	T <sub>stg</sub>	-40 to +150	°C	
Channel temperature	T <sub>ch</sub>	150	°C	
Output avalanche capability	E <sub>AV</sub>	100	mJ	Single pulse

## Electrical Characteristics

(V<sub>B</sub> = 14V, T<sub>c</sub> = -40 to +125°C unless otherwise specified)

Parameter	Symbol	Ratings			Unit	Conditions
		min	typ	max		
Power supply voltage	V <sub>Bopr</sub>	5.5		32	V	
Quiescent circuit current	I <sub>q</sub>		4	6	mA	All outputs are OFF
Input voltage	Hi output V <sub>IN</sub>	3.5		5.5	V	I <sub>O</sub> = 1.5A
	Lo output V <sub>IN</sub>	-0.5		1.5	V	
Input current	Hi output I <sub>IN</sub>			50	μA	V <sub>IN</sub> = 5V
	Lo output I <sub>IN</sub>			30	μA	V <sub>IN</sub> = 0V
Output ON voltage	V <sub>DS(on)</sub>		0.42	0.55	V	I <sub>O</sub> = 1A
			0.64	0.75	V	I <sub>O</sub> = 1.5A
Output ON resistance	R <sub>DS(on)</sub>		0.25	0.3	Ω	T <sub>a</sub> = 25°C
			0.3	0.4	Ω	T <sub>a</sub> = 25°C, V <sub>B</sub> = 5.5V
Output clamp voltage	V <sub>OUT(clamp)</sub>	41	45	55	V	V <sub>B</sub> = 14V, I <sub>D</sub> = 1A
Output leak current	I <sub>OH</sub>			100	μA	V <sub>O</sub> = 30V
Forward voltage of output stage diode	V <sub>F</sub>			1.5	V	I <sub>F</sub> = 1.5A
Overvoltage protection starting voltage	V <sub>B(ovp)</sub>	32		40	V	
Thermal protection starting temperature	T <sub>TSD</sub>	151	165		°C	
Overcurrent protection starting current	I <sub>S</sub>	1.9			A	
Output transfer time	T <sub>ON</sub>			15	μS	R <sub>L</sub> = 14Ω, I <sub>O</sub> = 1A
	T <sub>OFF</sub>			15	μS	R <sub>L</sub> = 14Ω, I <sub>O</sub> = 1A
Output rise time	T <sub>r</sub>			15	μS	R <sub>L</sub> = 14Ω, I <sub>O</sub> = 1A
Output fall time	T <sub>f</sub>			15	μS	R <sub>L</sub> = 14Ω, I <sub>O</sub> = 1A

## External Dimensions (unit: mm)

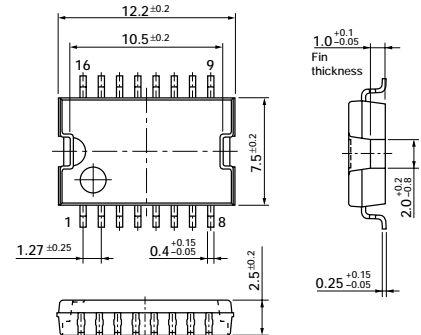

## Equivalent Circuit Diagram

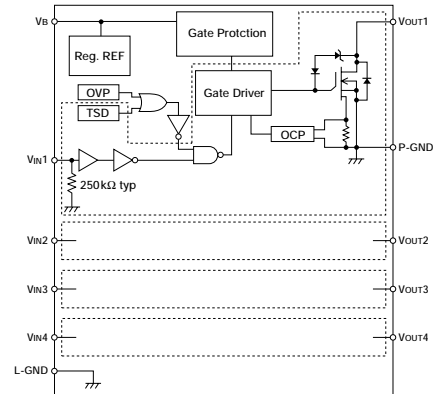

## Circuit Example

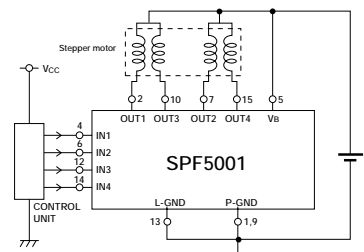

Use L-GND and P-GND being connected.

Truth table

V <sub>IN</sub>	V <sub>O</sub>
H	L
L	H

## Timing Chart

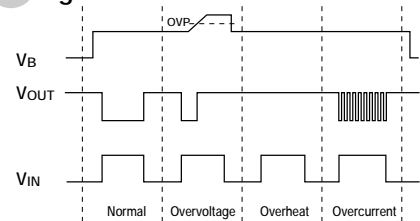

\* Self-excited frequency is used in the overcurrent protection.

■ Quiescent Circuit Current

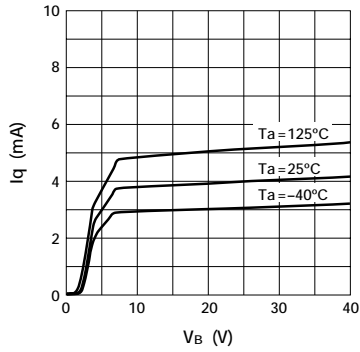

■ Circuit Current (single circuit)

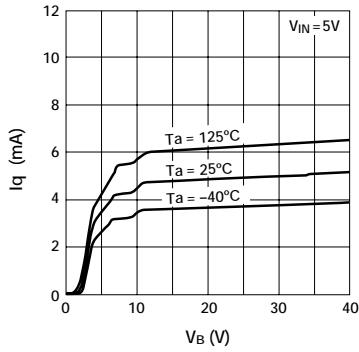

■ Circuit Current (4 circuits)

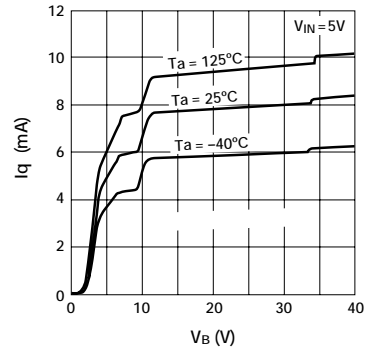

■ Threshold Input Voltage

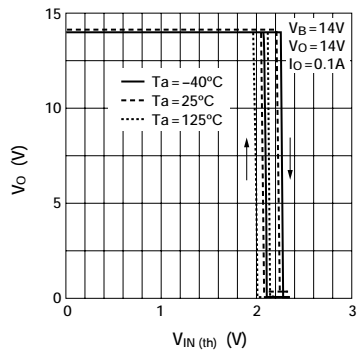

■ Output ON Voltage

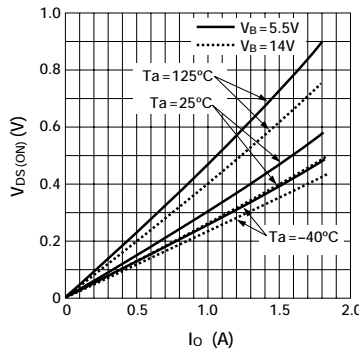

■ Forward Voltage of Output Stage Diode

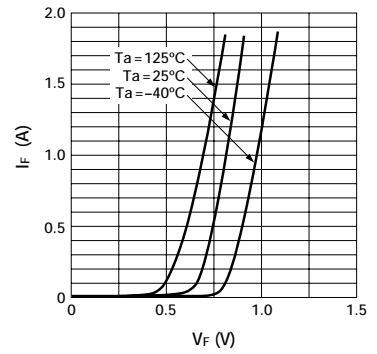

■ Overvoltage Protection Starting Voltage

