

FEATURES

- **NEW M03 PACKAGE:**
 - Smallest transistor outline package available
 - Low profile/0.59 mm package height
 - Flat lead style for better RF performance
- **HIGH GAIN BANDWIDTH PRODUCT:**
 $f_T = 12 \text{ GHz}$
- **LOW NOISE FIGURE:**
 $NF = 1.5 \text{ dB at } 2 \text{ GHz}$

DESCRIPTION

The NE685M03 transistor is designed for low noise, high gain, and low cost requirements. This high f_T part is well suited for very low voltage/low current designs for portable wireless communications and cellular radio applications. NEC's new low profile/flat lead style "M03" package is ideal for today's portable wireless applications. The NE685 is also available in six different low cost plastic surface mount package styles.

OUTLINE DIMENSIONS (Units in mm)

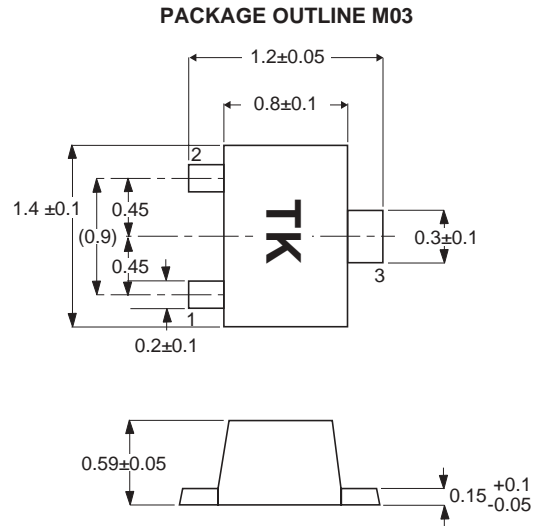

PIN CONNECTIONS

1. Emitter
2. Base
3. Collector

ELECTRICAL CHARACTERISTICS ($T_A = 25^\circ\text{C}$)

PART NUMBER EIAJ ¹ REGISTERED NUMBER PACKAGE OUTLINE		NE685M03 2SC5435 M03			
SYMBOLS	PARAMETERS AND CONDITIONS	UNITS	MIN	TYP	MAX
f_T	Gain Bandwidth at $V_{CE} = 3 \text{ V}$, $I_C = 10 \text{ mA}$, $f = 2 \text{ GHz}$	GHz		12	
NF	Noise Figure at $V_{CE} = 3 \text{ V}$, $I_C = 3 \text{ mA}$, $f = 2 \text{ GHz}$	dB		1.5	2.5
$ S_{21E} ^2$	Insertion Power Gain at $V_{CE} = 3 \text{ V}$, $I_C = 10 \text{ mA}$, $f = 2 \text{ GHz}$	dB	7	9	
h_{FE}^2	Forward Current Gain at $V_{CE} = 3 \text{ V}$, $I_C = 10 \text{ mA}$		75		140
I_{CBO}	Collector Cutoff Current at $V_{CB} = 5 \text{ V}$, $I_E = 0$	μA			0.1
I_{EBO}	Emitter Cutoff Current at $V_{EB} = 1 \text{ V}$, $I_C = 0$	μA			0.1
C_{RE}^3	Feedback Capacitance at $V_{CB} = 3 \text{ V}$, $I_E = 0$, $f = 1 \text{ MHz}$	pF		0.4	0.7

Notes:

1. Electronic Industrial Association of Japan.
2. Pulsed measurement, pulse width $\leq 350 \mu\text{s}$, duty cycle $\leq 2\%$.
3. Capacitance is measured with emitter and case connected to the guard terminal at the bridge.

ABSOLUTE MAXIMUM RATINGS¹ (T_A = 25°C)

SYMBOLS	PARAMETERS	UNITS	RATINGS
V _{CB0}	Collector to Base Voltage	V	9
V _{CE0}	Collector to Emitter Voltage	V	5
V _{EB0}	Emitter to Base Voltage	V	2
I _C	Collector Current	mA	30
P _T	Total Power Dissipation	mW	125
T _J	Junction Temperature	°C	150
T _{STG}	Storage Temperature	°C	-65 to +150

Note:

1. Operation in excess of any one of these parameters may result in permanent damage.

TYPICAL PERFORMANCE CURVES (T_A = 25°C)

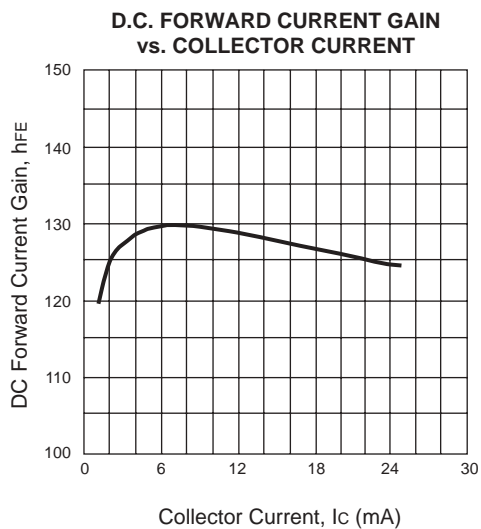
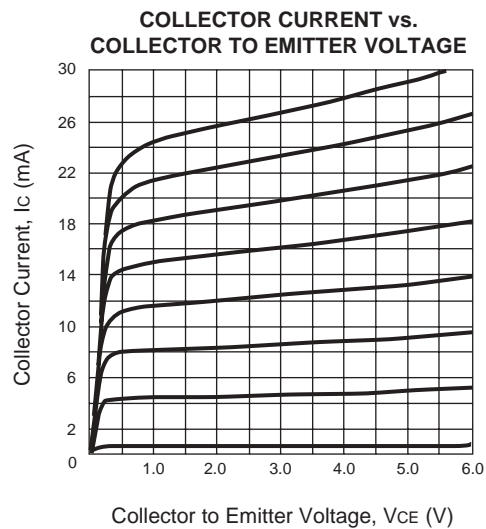

SCHEMATIC

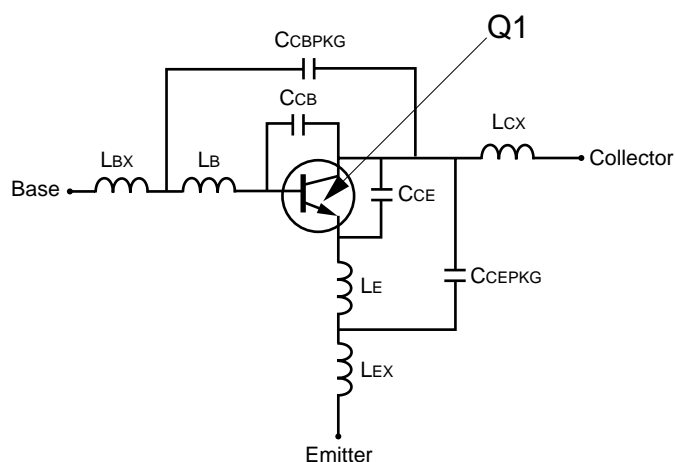

BJT NONLINEAR MODEL PARAMETERS (1)

Parameters	Q1	Parameters	Q1
IS	8.98e-17	MJC	0.19
BF	107.1	XCJC	0
NF	0.99	CJS	0
VAF	22	VJS	0.75
IKF	0.55	MJS	0
ISE	1e-6	FC	0.5
NE	31.10	TF	4e-12
BR	16.06	XTF	12
NR	0.98	VTF	1
VAR	6	ITF	0.04
IKR	8.02e-3	PTF	120
ISC	0	TR	1e-9
NC	2	EG	1.11
RE	0.6	XTB	0
RB	10	XTI	3
RBM	8.34	KF	0
IRB	0.009	AF	1
RC	5.07		
CJE	0.50e-12		
VJE	0.95		
MJE	0.5		
CJC	0.11e-12		
VJC	0.56		

(1) Gummel-Poon Model

UNITS

Parameter	Units
time	seconds
capacitance	farads
inductance	henries
resistance	ohms
voltage	volts
current	amps

ADDITIONAL PARAMETERS

Parameters	68533
CcB	0.13e-12
CcE	0.14e-12
Lb	0.3e-9
Le	0.8e-9
CcBPKG	0.08e-12
CcEPKG	0.08e-12
LbX	0.12e-9
LcX	0.10e-9
Lx	0.12e-9

MODEL RANGE

Frequency: 0.1 to 4.0 GHz
 Bias: $V_{CE} = 0.5 \text{ V to } 3 \text{ V}$, $I_C = 0.5 \text{ mA to } 20 \text{ mA}$
 Date: 11/98

Life Support Applications

These NEC products are not intended for use in life support devices, appliances, or systems where the malfunction of these products can reasonably be expected to result in personal injury. The customers of CEL using or selling these products for use in such applications do so at their own risk and agree to fully indemnify CEL for all damages resulting from such improper use or sale.

EXCLUSIVE NORTH AMERICAN AGENT FOR NEC RF, MICROWAVE & OPTOELECTRONIC SEMICONDUCTORS

CEL CALIFORNIA EASTERN LABORATORIES • Headquarters • 4590 Patrick Henry Drive • Santa Clara, CA 95054-1817 • (408) 988-3500 • Telex 34-6393 • FAX (408) 988-0279
 DATA SUBJECT TO CHANGE WITHOUT NOTICE

Internet: <http://WWW.CEL.COM>

06/10/2002