

## GaAs N-channel Dual-Gate MES FET

**Description:**

The 3SK147 is a GaAs N-channel Dual-Gate MES FET for low noise UHF amplifiers and mixers. Low noise, high gain characteristics and low operating voltage are accomplished by optimum mask pattern design. Simplified high frequency circuits adjustments are made possible by the miniaturized plastic molded package which contributes to reduce parasitic elements of the device.

**Features:**

- Low Operating Voltage
- Low NF: NF = 1.2 dB (typ.) at 800MHz
- High PG: PG = 22 dB (typ.) at 800 MHz
- High Stability
- Protection Diode Included

**Applications:**

- UHF T.V. Tuner, amplifier, mixer, oscillator.

**Absolute Maximum Ratings: (Ta = 25°C)**

- Drain to Source Voltage: Vdsx 12 V
- Gate 1 to Source Voltage: Vg1s -5 V
- Gate 2 to Source Voltage: Vg2s -5 V
- Drain Current: Id 55 mA
- Power Dissipation: Pch 150 mW
- Channel Temperature: Tch +150 °C
- Storage Temperature: Tstg -55 ~ +150 °C

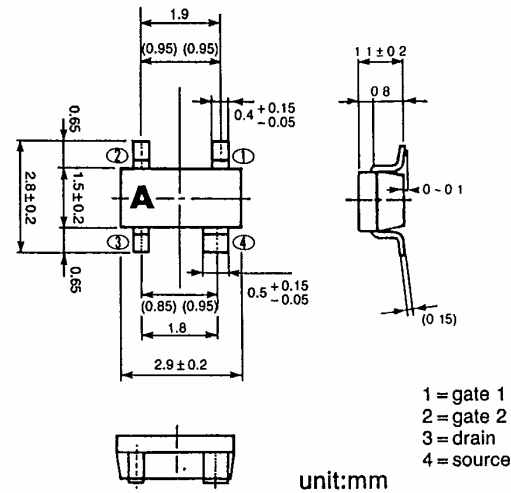
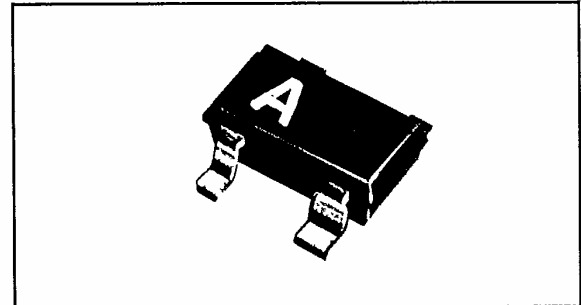

**Electrical Characteristics: (Ta = 25°C)**

Parameter	Symbol	Condition	Min.	Typ.	Max.	Unit
Drain to Source Voltage	Vdsx	Id = 20μA Vg1s = 0V Vg2s = -4V	11			V
Gate 1 Cutoff Current	Ig1ss	Vg1s = -4.5V Vg2s = 0V Vds = 0V	-8			μA
Gate 2 Cutoff Current	Ig2ss	Vg2s = -4.5V Vg1s = 0V Vds = 0V	-8			μA
Drain Saturation Current	Idss	Vds = 5V Vg1s = 0V Vg2s = 0V	10		50	mA
Gate 1 Pinchoff Voltage	Vp1	Vds = 5V Id = 100μA Vg2s = 0V	-2.5			V
Gate 2 Pinchoff Voltage	Vp2	Vds = 5V Id = 100μA Vg1s = 0V	-2.5			V
Transconductance	gm	Vds = 5V Id = 10mA Vg2s = 1.5V f = 1KHz	20	26		mS
Input Capacitance	Ciss	Vds = 5V Id = 10mA Vg2s = 1.5V f = 1MHz		1.1	3	PF
Feedback Capacitance	Crss			28	40	fF
Power Gain	PG	Vds = 5V Id = 10mA Vg2s = 1.5V	18	22		dB
Noise Figure	NF	f = 800MHz		1.2	2.0	dB

The specifications are subject to change without notice.

Output Characteristics: ( $T_a = 25^\circ\text{C}$ ,  $V_{g2s} = 1.5\text{V}$ ,  $V_{g1s} = -0.2\text{Vstep}$ )

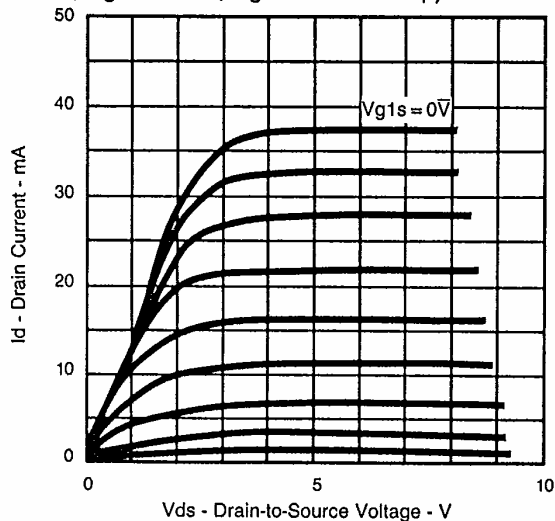

NF, Ga Frequency Dependence: ( $V_{ds} = 5.0\text{V}$ ,  $V_{g2s} = 1.5\text{V}$ ,  $I_{ds} = 10\text{mA}$ )

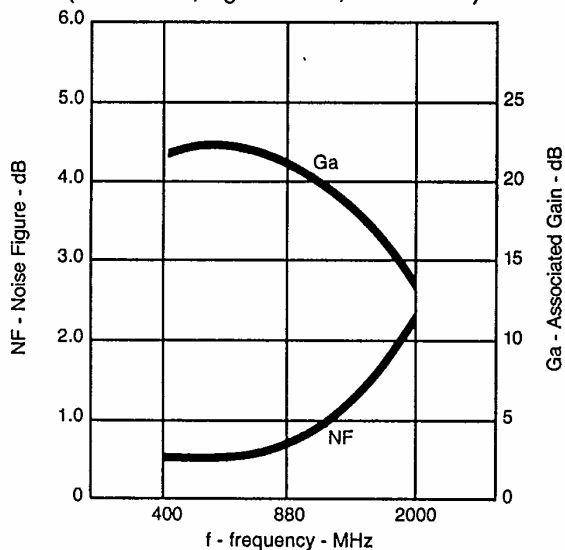

NF-Id Characteristics: ( $V_{ds} = 5.0\text{V}$ ,  $V_{g2s} = 1.5\text{V}$ , Frequency at 450MHz)

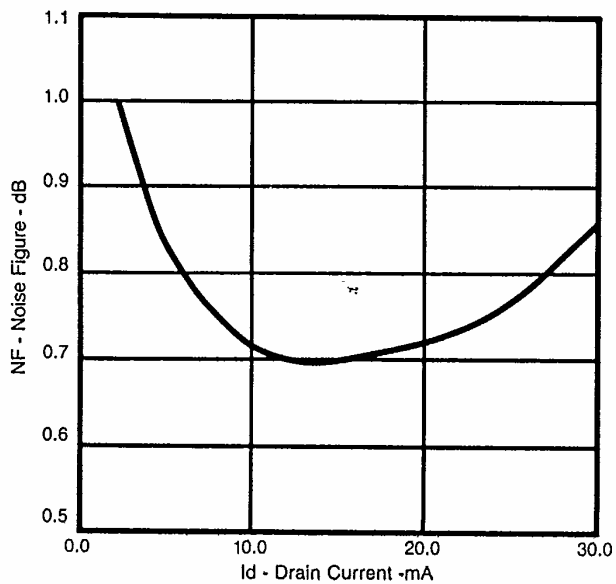

7

S-Parameters vs. Frequency Characteristics: (V<sub>ds</sub> = 5V, V<sub>g2s</sub> = 1.5V, I<sub>d</sub> = 10mA)

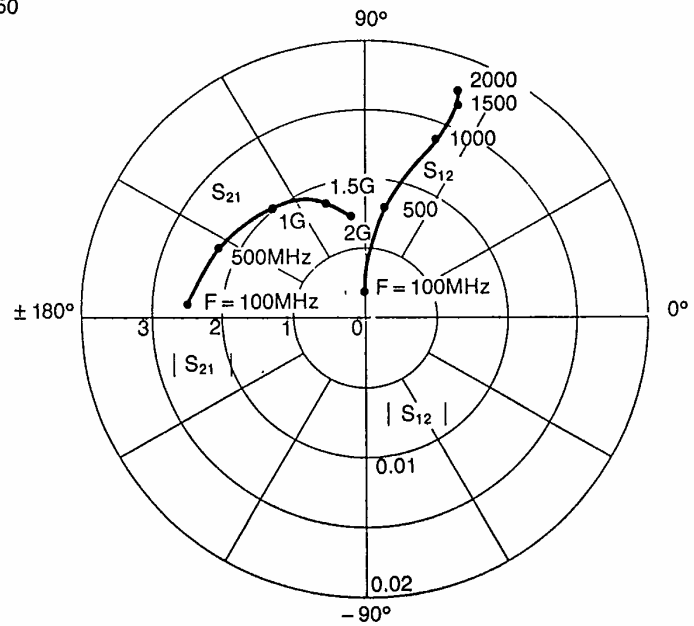
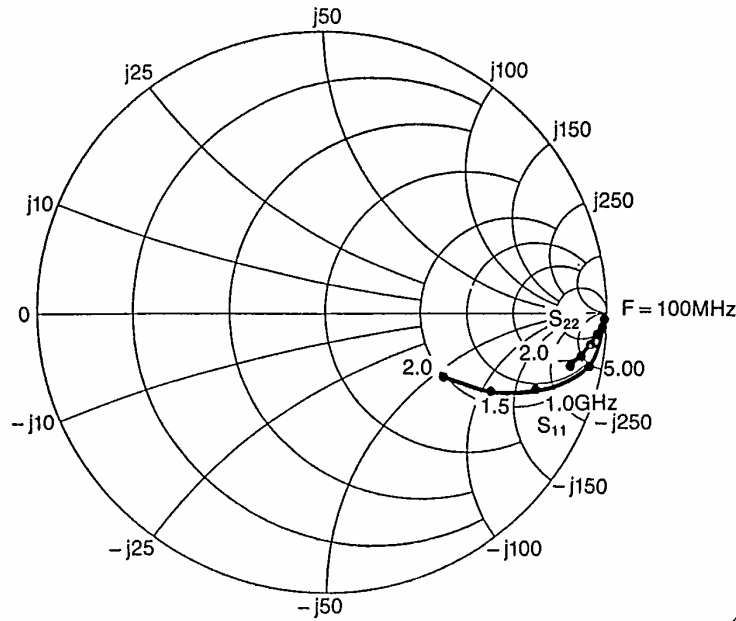

S-Parameter Data of FET 3SK147 (50.0 Ohm reference)

Frequency MHz	S11		S21		S12		S22	
	MAG	ANG	MAG	ANG	MAG	ANG	MAG	ANG
100	.996	-4.29	2.463	174.58	0.0017	90.33	.969	-1.24
200	.991	-8.41	2.429	167.53	0.0032	82.30	.970	-2.71
300	.992	-12.08	2.423	161.43	0.0042	85.75	.981	-5.05
400	.967	-16.21	2.415	160.18	0.0072	85.39	.962	-5.36
500	.944	-19.67	2.288	154.96	0.0080	79.42	.961	-6.27
600	.920	-23.29	2.275	147.32	0.0097	77.89	.964	-7.75
700	.892	-26.72	2.233	144.80	0.0111	74.26	.954	-8.54
800	.865	-29.98	2.128	140.64	0.0117	75.69	.952	-10.22
900	.836	-32.83	2.018	133.59	0.0125	71.74	.940	-10.92
1000	.807	-35.39	2.079	128.17	0.0139	68.31	.940	-12.55
1200	.736	-40.18	1.874	123.16	0.0162	69.28	.932	-15.15
1400	.672	-44.73	1.845	114.38	0.0174	64.55	.919	-17.33
1600	.615	-48.21	1.676	108.69	0.0173	68.24	.915	-18.83
1800	.547	-50.41	1.655	102.68	0.0179	66.81	.908	-19.93
2000	.471	-53.14	1.435	95.70	0.0178	68.29	.892	-21.04

3

**Noise Figure Characteristics: (Vds = 5.0V, Vg2s = 1.5V, Ids = 10mA)**  
 at 450MHz

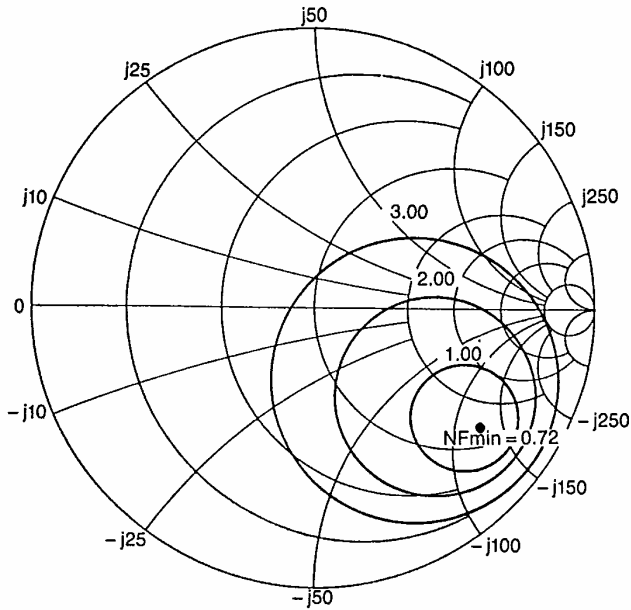

Vds = 5.0V  
 Vg2s = 1.5V  
 Ids = 10mA  
 Frequency 450 MHz  
 NF min 0.72 dB  
 Ga 20.57 dB  
 Gamma (S); Mag 0.730 Ang -35.46°  
 Gamma (L); Mag 0.833 Ang -46.85°

at 880MHz

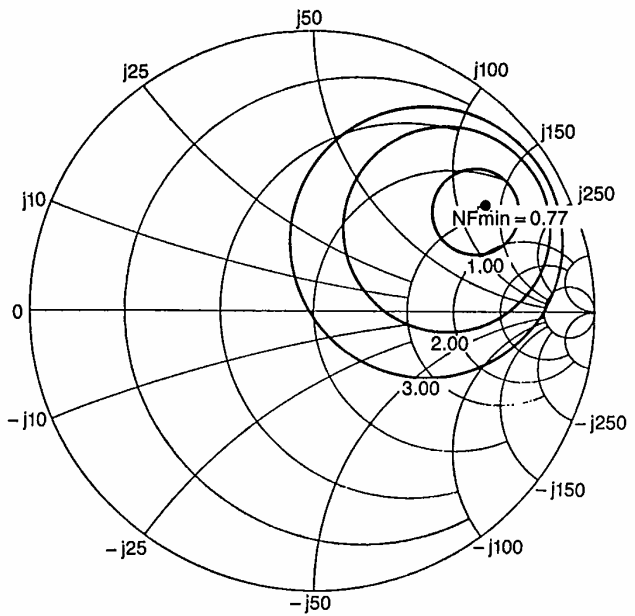

Vds = 5.0V  
 Vg2s = 1.5V  
 Ids = 10mA  
 Frequency 880 MHz  
 NF min 0.77 dB  
 Ga 20.57 dB  
 Gamma (S); Mag 0.725 Ang 32.68°

at 2000MHz

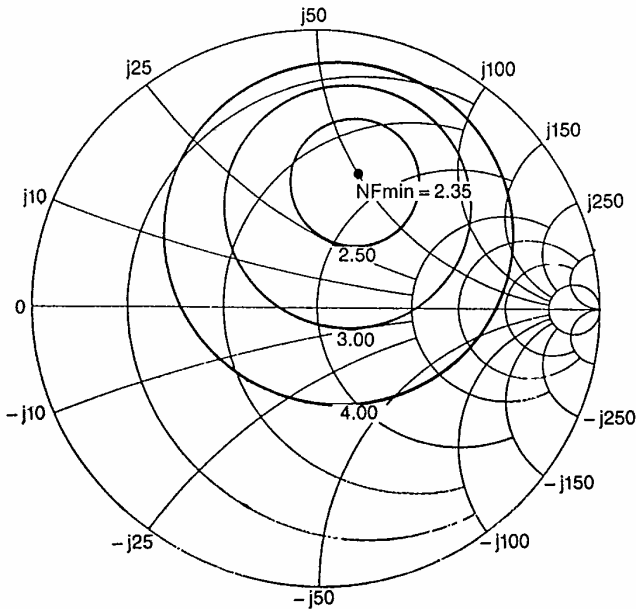

Vds = 5.0V  
 Vg2s = 1.5V  
 Ids = 10mA  
 Frequency 2000 MHz  
 NF min 2.35 dB  
 Ga 13.38 dB  
 Gamma (S); Mag 0.510 Ang 73.32°

Frequency (MHz)	Ga (dB)	NF (dB)	Gamma- S		Gamma- L	
			(Mag.)	(Ang.)	(Mag.)	(Ang.)
400	21.69	0.60	0.747	-78.04°	0.912	-76.72°
450	20.57	0.72	0.730	-35.46°	0.833	-46.85°
500	22.03	0.71	0.813	4.63°	0.560	-5.95°
880	20.75	0.77	0.725	32.68°		
2000	13.38	2.35	0.510	73.32°		



Sony Component Products Division  
 West Coast Main Office: 23430 Hawthorne Blvd., Suite No. 330, Torrance, California 90505 213-373-9425  
 Northwest Office: 1359 Old Oakland Road, San Jose, California 95112 408-280-0111  
 East Coast Office: 15 Essex Road, Paramus, New Jersey 07653 201-368-5020