

## 1. OVERVIEW

CLAA150XA03 is 15.0" color TFT-LCD (Thin Film Transistor Liquid Crystal Display) module composed of LCD panel, driver ICs, control circuit and backlight.

By applying 8 bit digital data, 1024×768, 16.7M-color images are displayed on the 15.0" diagonal screen. Input power voltage is 5.0V for LCD driving.

Interface of data and control signals is Typ. 32.5MHz digital. 2 pixel data are transmitted per cycle. General specifications are summarized in the following table:

ITEM	SPECIFICATION
Display Area(mm)	304.1(H)×228.1(V) (15.0-inch diagonal)
Number of Pixels	1024(H)×768(V)
Pixel Pitch(mm)	0.297(H)×0.297(V)
Color Pixel Arrangement	RGB vertical strip
Display Mode	normally white TN
Number of Colors	16.7M(8bits/color)
Brightness(cd/m <sup>2</sup> )	(300)(cd/m <sup>2</sup> )(Typ.)
Viewing Angle	-60~60(H),-55~45(V)(Typ.)
Wide Viewing Angle Technology	Optical Compensation Film
Surface Treatment	Anti-glare
Electrical Interface	CMOS(VIN=3~5V,2 pixel/clock)
Total Module Power(W)	11.0(Typ.)
Optimum Viewing Angle	6 o'clock
Module Size(mm)	350.0(W) × 266.5(H) × 14.5(D)
Module Weight(g)	1300
Backlight Unit	2 replaceable CCFLs edge-light(top/bottom)

( )For reference only.

The LCD Products listed on this document are not suitable for use of aerospace equipment, submarine cables, nuclear reactor control system and life support systems. If customers intend to use these LCD products for above application or not listed in "Standard" as follows, please contact our sales people in advance.

Standard: Computer, Office equipment, Communication equipment, Test and Measurement equipment, Machine tool, Industrial robot, Audio and Visual equipment, Other consumer products.

## 2. ABSOLUTE MAXIMUM RATINGS

ITEM	SYMBOL	MIN.	MAX.	UNIT
Power Supply Voltage for LCD	VCC	0	7.0	V
Logic input Voltage	High	V <sub>IH</sub>	6.1	V
	Low	V <sub>IL</sub>	-0.5	V
Operation Temperature *1)	Top	0	50	°C
Storage Temperature *1)	T <sub>stg</sub>	-20	60	°C

Note:

\*1)Humidity

Relative Humidity ≤ 95% (T<sub>a</sub> ≤ 40°C)

Wet Bulb Temperature ≤ 39°C (T<sub>a</sub> ≥ 40°C)

## 3. ELECTRICAL CHARACTERISTICS

(a)TFT-LCD

ITEM	SYMBOL	MIN	TYP	MAX	UNIT	Remark
Power Supply Voltage for LCD	VCC	4.5	5.0	5.5	V	Note1
Power Supply Current for LCD	ICC	-	350	(600)	mA	Note2
Permissible Input Ripple Voltage	VRP	-	-	100	mVp-p	V <sub>cc</sub> =5.0V
Input Threshold Voltage	High	V <sub>TH</sub>	2.2	3.3	V	
	Low	V <sub>TL</sub>	0	-	0.8	V

[Note 1]

VCC-turn-on conditions:

$$t1 \leq 50 \text{ ms}$$

$$0 < t2 \leq 50 \text{ ms}$$

$$0 < t3 \leq 1 \text{ s}$$

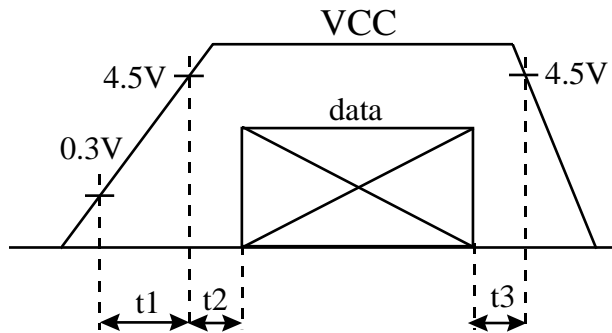

VCC-dip conditions

1) When  $3.6\text{V} \leq VCC < 4.5\text{V}$

$$td \leq 10 \text{ ms}$$

2)  $VCC < 3.6\text{V}$

VCC-dip conditions should also follow the VCC-turn-on conditions.

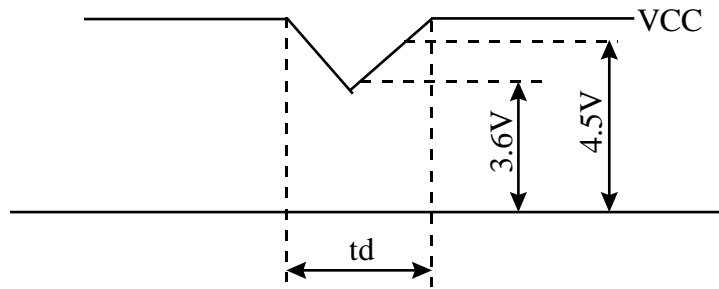

[Note 2] Typical current situation : 256-gray-bar pattern, 768 line mode,  $VCC = +5.0\text{V}$

(b) Backlight

ITEM	SYMBOL	MIN	TYP	MAX	UNIT	REMARK
Lamp Voltage	VL	-	625	-	V	$IL = 7.0\text{mA}$
Lamp Current	IL	5.0	7.0	8.5	mA	Note1
Interter Frequency	FI	30	40	50	kHz	
Starting Lamp Voltage	VS	1700	-	-	V	$Ta = 0^\circ\text{C}$
		1500	-	-	V	$Ta = 25^\circ\text{C}$
Lamp life Time	LT	25000	-	-	hr	$IL = 7.0\text{Ma}$ Continuous Operation

[Note 1] Lamp Current measurement method ( The current meter is inserted in cold line)

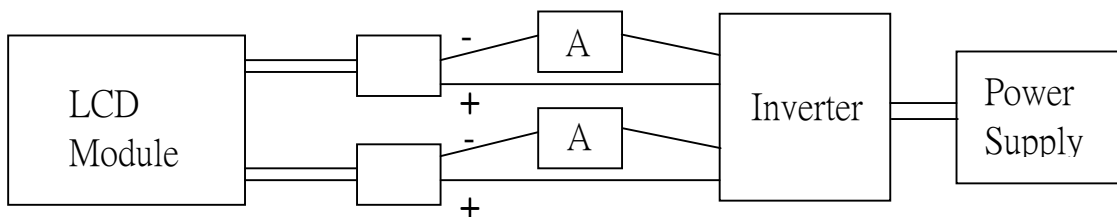

## 4. INTERFACE PIN CONNECTION

(a) CN1(Data Signal and Power Supply)

Used connector:IL-FHR45S-HF(JAE)

pin	Symbol	Function
1	GND	
2	CLK	Dot clock
3	GND	
4	DENA	Data enable
5	GND	
6	VD	Vertical sync
7	GND	
8	HD	Horizontal sync
9	GND	
10	NC	(HMS)
11	GND	
12	BO7	Blue odd data(MSB)
13	BO6	Blue odd data
14	BO5	Blue odd data
15	BO4	Blue odd data
16	GND	
17	BO3	Blue odd data
18	BO2	Blue odd data
19	BO1	Blue odd data
20	BO0	Blue odd data(LSB)
21	GND	
22	GO7	Green odd data(MSB)
23	GO6	Green odd data
24	GO5	Green odd data
25	GO4	Green odd data
26	GND	
27	GO3	Green odd data
28	GO2	Green odd data
29	GO1	Green odd data
30	GO0	Green odd data(LSB)
31	GND	
32	RO7	Red odd data(MSB)
33	RO6	Red odd data
34	RO5	Red odd data
35	RO4	Red odd data
36	GND	
37	RO3	Red odd data
38	RO2	Red odd data
39	RO1	Red odd data
40	RO0	Red odd data(LSB)
41	VCC	
42	VCC	
43	TEST	Should be open during operation(Internal test only)
44	TEST	Should be open during operation(Internal test only)
45	TEST	Should be open during operation(Internal test only)

(b) CN2(Data Signal)

Used connector:IL-FHR-30S-HF(JAE)

Pin No.	Symbol	Function
1	GND	
2	BE7	Blue even data(MSB)
3	BE6	Blue even data
4	BE5	Blue even data
5	BE4	Blue even data
6	GND	
7	BE3	Blue even data
8	BE2	Blue even data
9	BE1	Blue even data
10	BE0	Blue even data(LSB)
11	GND	
12	GE7	Green even data(MSB)
13	GE6	Green even data
14	GE5	Green even data
15	GE4	Green even data
16	GND	
17	GE3	Green even data
18	GE2	Green even data
19	GE1	Green even data
20	GE0	Green even data(LSB)
21	GND	
22	RE7	Red even data(MSB)
23	RE6	Red even data
24	RE5	Red even data
25	RE4	Red even data
26	GND	
27	RE3	Red even data
28	RE2	Red even data
29	RE1	Red even data
30	RE0	Red even data(LSB)

(c)CN3,4(BACKLIGHT)

Backlight-side connector: BHR-03VS-1(JST)

Inverter-side connector: SM02(8.0)B-BHS-1(JST)

Pin No.	Symbol	Function
1	CTH	VBLH(High voltage)
3	CTL	VBLH(High voltage)

[Note]

VBLH-VBLL = VL

## 5. INTERFACE TIMING

### (a) Timing Specifications

	ITEM	SYMBOL	MIN	TYP	MAX	UNIT
DCLK *1)*4)	Frequency	fCLK	30	32.5	40	MHz
	Period	tCLK	25.0	30.8	33.3	ns
	Low Width	tWCL	0.3	0.5	0.7	tCLK
	High Width	tWCH	0.3	0.5	0.7	tCLK
	Rise Time	tr	-	-	5	ns
	Fall Time	tf	-	-	5	ns
DATA(R,G,B,DE NA,HD,VD)	Set up Time	tDs	2.3	-	-	ns
	Hold Time	tDh	7.3	-	-	ns
	Rise Time	tr	-	-	5	ns
	Fall Time	tf	-	-	5	ns
DENA *3)	Low width	tWDL	6	-	-	tCLK
	Horizontal Front Porch	tHFP	0	-	-	tCLK
	Horizontal Back Porch	tHBP	6	-	-	tCLK
	Vertical Front Porch	tVFP	0	-	-	tH
	Vertical Back Porch	tVBP	4	-	-	tH
HD *2) *4)	Frequency	fH	-	48.4	62.5	kHz
	Period	tH	16	20.7	-	us
	Low width	tWHL	1	-	-	tCLK
VD *2)	Frequency	fV	55	60	75	Hz
	Period	tV	13.3	16.7	18.2	ms
	Low width	tWVL	1	-	-	tH

[Note]

- 1) Data is latched at fall edge of DCLK in this specification.
- 2) Polarities of HD and VD are negative in this specification.
- 3) DENA (Data Enable) should always be positive polarity as shown in the timing specification.
- 4) DCLK should appear during all blanking period, and HD should appear during blanking period of frame cycle.

(b)Timing Chart

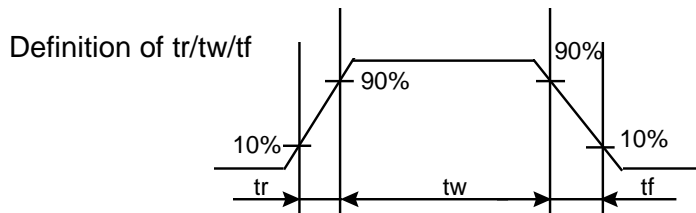
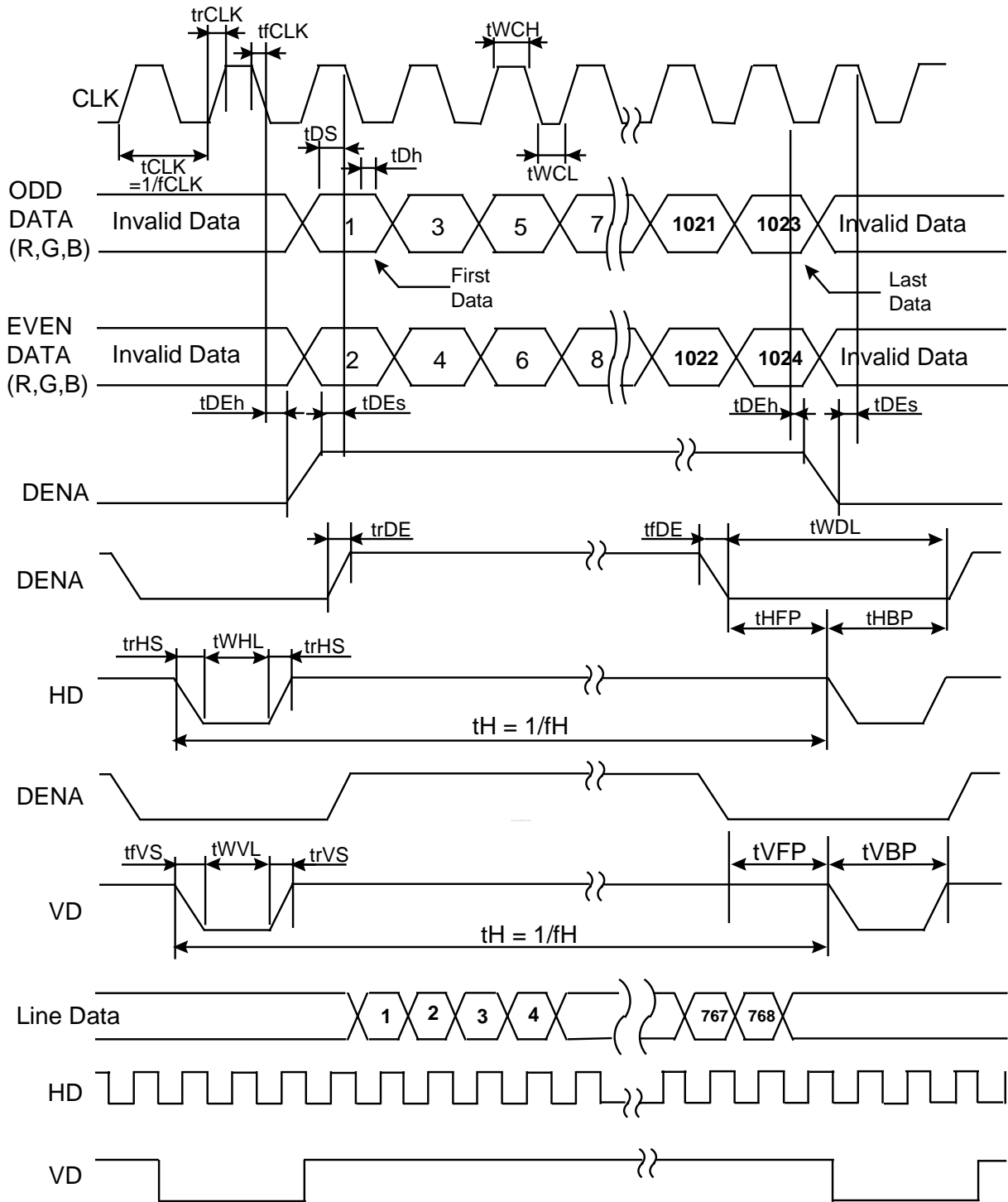

(c)Color Data Assignment

COLOR	INPUT DATA	R DATA								G DATA								B DATA							
		R7 MSB	R6	R5	R4	R3	R2	R1	R0 LSB	G7 MSB	G6	G5	G4	G3	G2	G1	G0 LSB	B7 MSB	B6	B5	B4	B3	B2	B1	B0 LSB
BASIC COLOR	BLACK	0	0	0	0	0	0	0	0	0	0	0	0	0	0	0	0	0	0	0	0	0	0	0	0
	RED(255)	1	1	1	1	1	1	1	1	0	0	0	0	0	0	0	0	0	0	0	0	0	0	0	
	GREEN(255)	0	0	0	0	0	0	0	0	1	1	1	1	1	1	1	0	0	0	0	0	0	0	0	
	BLUE(255)	0	0	0	0	0	0	0	0	0	0	0	0	0	0	0	1	1	1	1	1	1	1	1	
	CYAN	0	0	0	0	0	0	0	0	1	1	1	1	1	1	1	1	1	1	1	1	1	1	1	
	MAGENTA	1	1	1	1	1	1	1	1	0	0	0	0	0	0	0	1	1	1	1	1	1	1	1	
	YELLOW	1	1	1	1	1	1	1	1	1	1	1	1	1	1	1	0	0	0	0	0	0	0	0	
	WHITE	1	1	1	1	1	1	1	1	1	1	1	1	1	1	1	1	1	1	1	1	1	1	1	
RED	RED(0)	0	0	0	0	0	0	0	0	0	0	0	0	0	0	0	0	0	0	0	0	0	0		
	RED(1)	0	0	0	0	0	0	0	1	0	0	0	0	0	0	0	0	0	0	0	0	0	0		
	RED(2)	0	0	0	0	0	0	1	0	0	0	0	0	0	0	0	0	0	0	0	0	0	0		
	RED(254)	1	1	1	1	1	1	1	0	0	0	0	0	0	0	0	0	0	0	0	0	0	0		
	RED(255)	1	1	1	1	1	1	1	1	0	0	0	0	0	0	0	0	0	0	0	0	0	0		
GREEN	GREEN(0)	0	0	0	0	0	0	0	0	0	0	0	0	0	0	0	0	0	0	0	0	0	0		
	GREEN(1)	0	0	0	0	0	0	0	0	0	0	0	0	0	1	0	0	0	0	0	0	0	0		
	GREEN(2)	0	0	0	0	0	0	0	0	0	0	0	0	1	0	0	0	0	0	0	0	0			
	GREEN(254)	0	0	0	0	0	0	0	1	1	1	1	1	1	0	0	0	0	0	0	0	0			
	GREEN(255)	0	0	0	0	0	0	0	1	1	1	1	1	1	1	0	0	0	0	0	0	0			
BLUE	BLUE(0)	0	0	0	0	0	0	0	0	0	0	0	0	0	0	0	0	0	0	0	0	0	0		
	BLUE(1)	0	0	0	0	0	0	0	0	0	0	0	0	0	0	0	0	0	0	0	0	0	1		
	BLUE(2)	0	0	0	0	0	0	0	0	0	0	0	0	0	0	0	0	0	0	0	0	1	0		
	BLUE(254)	0	0	0	0	0	0	0	0	0	0	0	0	0	0	1	1	1	1	1	1	1	0		
	BLUE(255)	0	0	0	0	0	0	0	0	0	0	0	0	0	0	1	1	1	1	1	1	1	1		

[Note]

(1)Definition of gray scale:

Color(n) : n indicates gray scale level.

Higher n means brighter level.

(2)Data:1-High,0-Low.

(3)This assignment is applied to both odd and even data.

(d)Color Data Assignment

D(1,1)	D(2,1)	..	D(X,1)	..	D(1023,1)	D(1024,1)
D(1,2)	D(2,2)	..	D(X,2)	..	D(1023,2)	D(1024,2)
..	..	+	..	+	..	..
D(1,Y)	D(2,Y)	..	D(X,Y)	..	D(1023,Y)	D(1024,Y)
..	..	+	..	+	..	..
D(1,767)	D(2,767)	..	D(X,767)	..	D(1023,767)	D(1024,767)
D(1,768)	D(2,768)	..	D(X,768)	..	D(1023,768)	D(1024,768)

## 6. BLOCK DIAGRAM

TFT-LCD Module

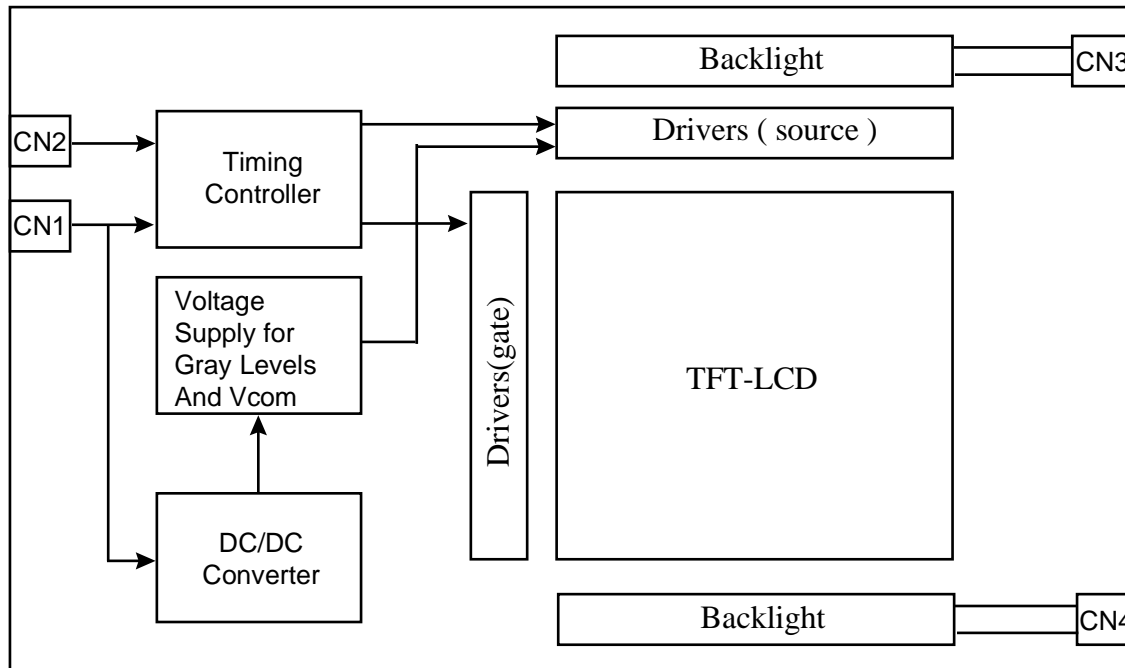

BACK LIGHT

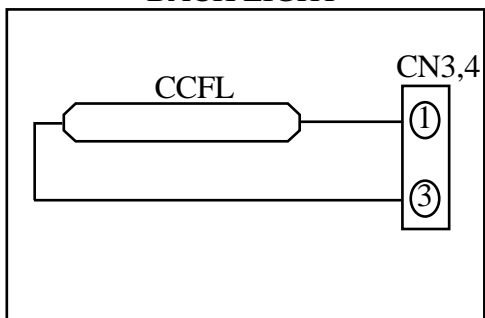

INVERTER CIRCUIT (OUT SIDE)

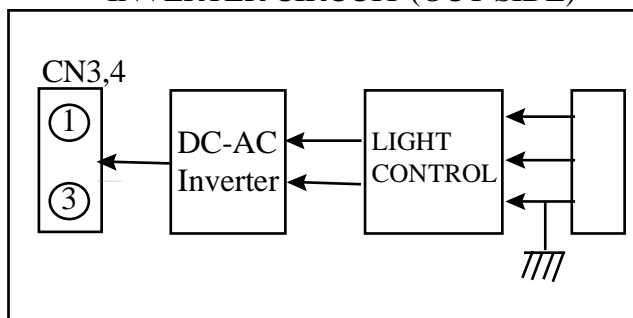





(b) Rear side

Unit: mm

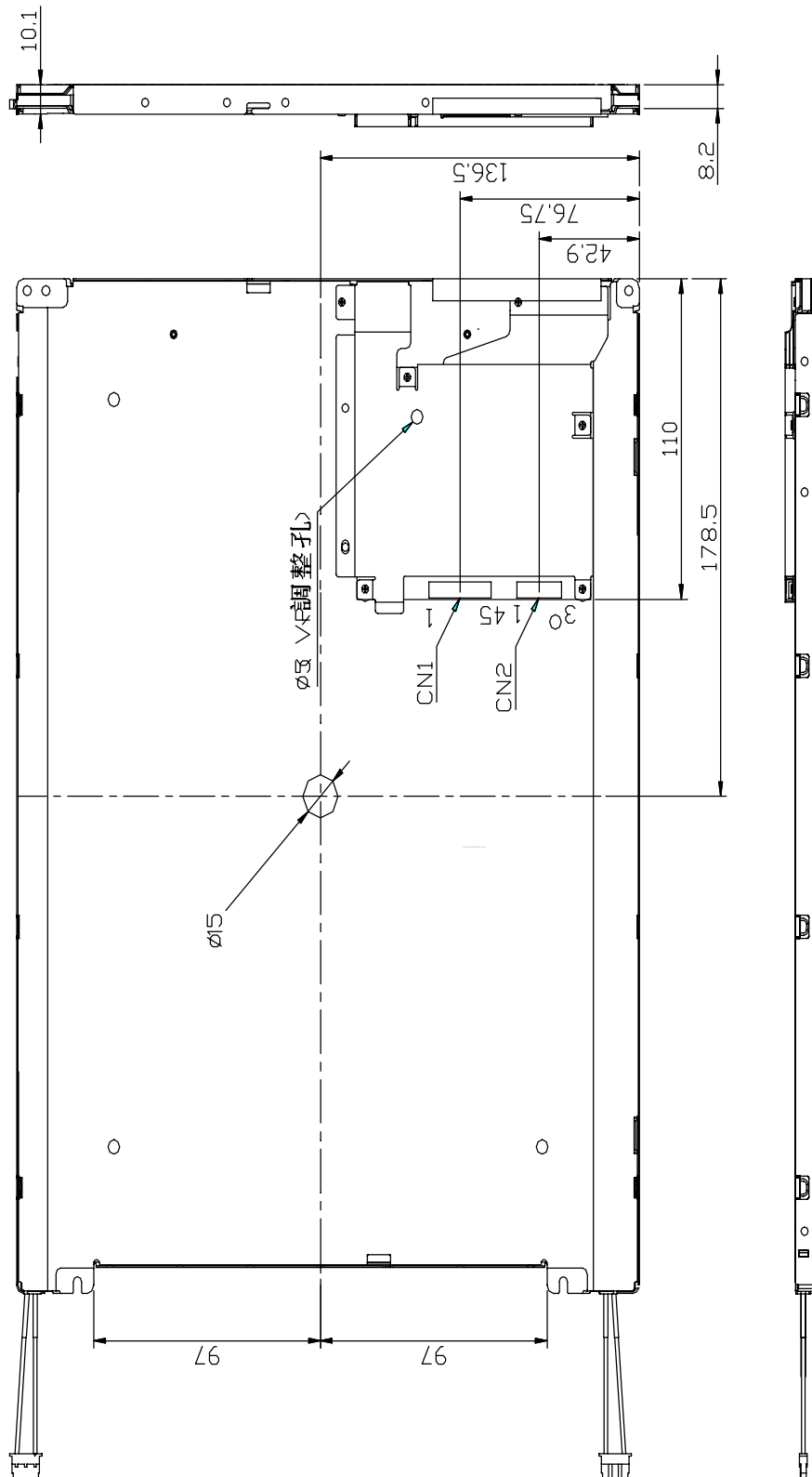

(C) LABEL POSITION :

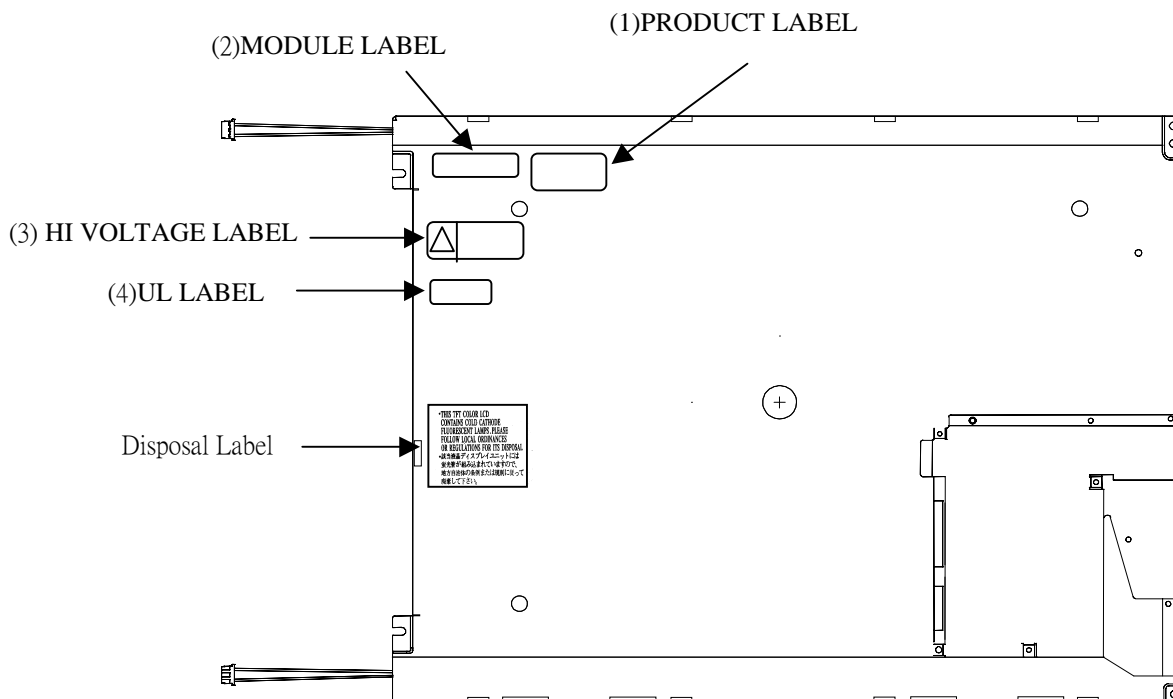

(1) PRODUCT LABEL : (MODEL NAME : CLAA150XA03)

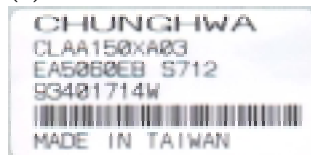

(2) MODULE LABEL :

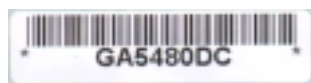

(3) HI VOLTAGE LABEL :

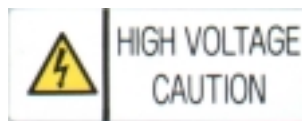

(4) UL LABEL :



(5) Disposal Label



CTAAXXX for UL apply, other safety apply use CLAAXXX.

# 8.OPTICAL CHARACTERISTICS

Ta=25°C, VCC=5.0V

ITEM	SYMBOL	CONDITION	MIN.	TYP.	MAX.	UNIT	
Contrast Ratio	CR	$\varphi = \theta = 0^\circ$	(200)	(350)	-	-	
Luminance	Normal	$\varphi = \theta = 0^\circ$	(200)	(300)		cd/m <sup>2</sup>	
	Uniformity	$\Delta L$	$\varphi = \theta = 0^\circ$	-	-	30	%
Response Time		tr	$\varphi = \theta = 0^\circ$	-	13	-	ms
		tf	$\varphi = \theta = 0^\circ$	-	27	-	ms
Viewing Angle	Horizontal	$\varphi$	CR $\geq 10$	(-50~50)	(-60~60)	-	°
	Vertical	$\theta$		(-45~40)	(-55~45)	-	°
Image sticking	tis	2 hours	-	-	2	s	
Color Coordinates	Red	x	$\varphi = \theta = 0^\circ$	0.567	0.597	0.627	-
		y		0.313	0.343	0.373	
	Green	x		0.286	0.316	0.346	
		y		0.536	0.566	0.596	
	Blue	x		0.123	0.153	0.183	
		y		0.101	0.131	0.161	
	White	x		0.280	0.310	0.340	
		y		0.298	0.328	0.358	

( ) For reference only.

These items are measured using BM-5A(TOPCON) OR LCD-7000 (Otsuka Electronic) under the dark room condition( no ambient light) after more than 30 minutes from turning on the lamp unless noted.

\*) Condition: IL=7.0mA, Inverter frequency: 40kHz.

Definition of these measurement items are as follows:

(1)Definition of Contrast Ratio

$$CR = ON(White)Luminance / OFF(Black)Luminance$$

(2)Definition of Luminance and (3)Definition of Viewing Angle( $\theta, \varphi$ )

Luminance uniformity

$$\Delta L = [L(MAX) / L(MIN) - 1] \times 100$$

Measure White Luminance on the below 5 points

### MEASUREMENT POINTS

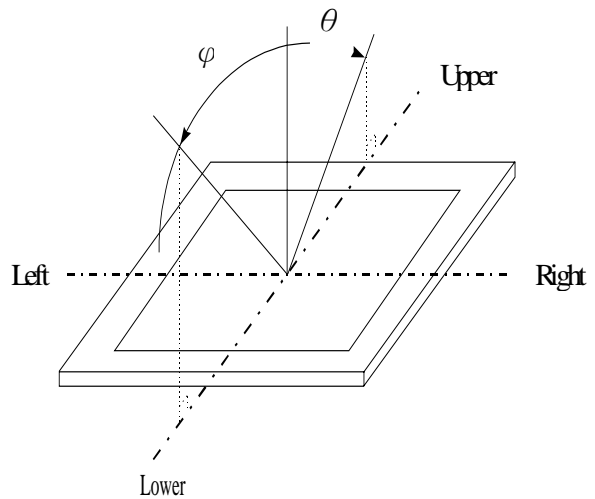
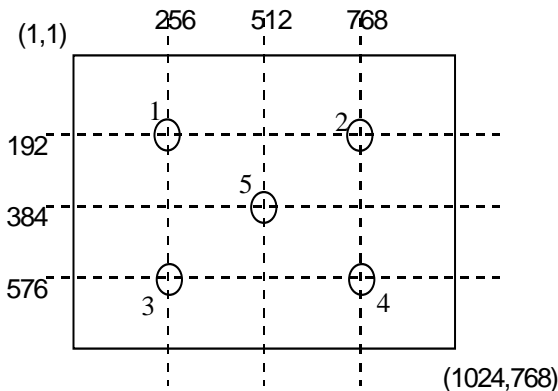

(4)Definition of Response Time

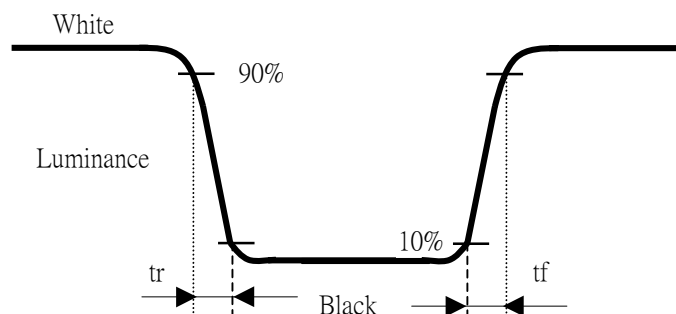

(5)Image sticking:

Continuously display the test pattern shown in the figure below for two-hours. Then display a completely white screen. The previous image shall not persist more than two seconds at 25°C.

**TEST PATTERN FOR IMAGE STICKING TEST**

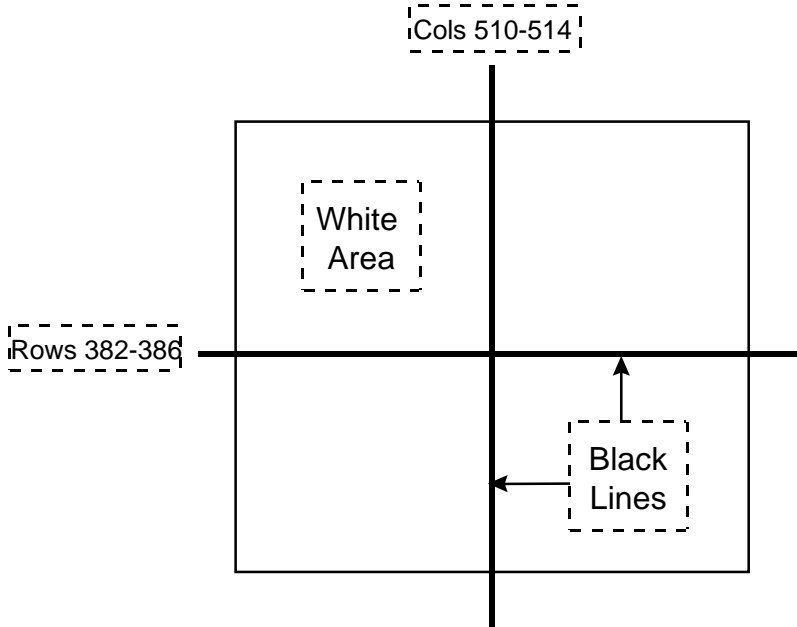

**9.RELIABILITY TEST CONDITIONS**

(1)Temperature and Humidity

TEST ITEMS	CONDITIONS
HIGH TEMPERATURE	40°C ,95%RH,240h
HIGH HUMIDITY OPERATION	(No condensation)
HIGH TEMPERATURE OPERATION	50°C ,240h
LOW TEMPERATURE STORAGE	-20°C ,240h
THERMAL SHOCK	BETWEEN -20°C (1hr)AND 60°C (1hr),5 CYCLES
HIGH TEMPERATURE STORAGE	60°C ,240h
LOW TEMPERATURE OPERATION	0°C ,240h

(2)Shock & Vibration

ITEMS	CONDITIONS
SHOCK (NON-OPERATION)	Shock level:980m/s <sup>2</sup> (100G) Waveform: half sinusoidal wave, 2ms Number of shocks: one shock input in each direction of three mutually perpendicular axes for a total of six shock inputs
VIBRATION (NON-OPERATION)	Vibration level: 9.8m/s <sup>2</sup> (1.0G) zero to peak Waveform: sinusoidal Frequency range: 5 to 500 Hz Frequency sweep rate: 0.5 octave/min Duration: one sweep from 5 to 500 to 5 Hz in each of three mutually perpendicular axis(each x,y,z axis: 1 hour, total 3 hours)

(3)Judgment standard

The judgment of the above test should be made as follow:

- Pass: Normal display image with no obvious non-uniformity and no line defect.
- Partial transformation of the module parts should be ignored.
- Fail: No display image, obvious non-uniformity, or line defects.

## 10. INSPECTION STANDARDS

Inspection condition is as follows:

Viewing distance is approximately 35cm.

Viewing angle is normal to the LCD panel.

Ambient temperature is approximately 25°C

Ambient light is from 300 to 500 lux

Bright Dot is defined as follows:

Visible through 5% transmission ND filter

$L > 4 * W$  shall be considered as linear defect

$L < 4 * W$  shall be considered as spot defect

DEFECT TYPE		LIMIT	
VISUAL DEFECT	SCRATCH	$0.01\text{mm} \leq W \leq 0.05\text{mm}$ $L \leq 10\text{mm}$	$N \leq 4$
		$0.01\text{mm} \leq W$ $10\text{mm} < L$	$N = 0$
		$0.05\text{mm} < W$	$N = 0$
	DENT	$0.15\text{mm} \leq \varphi \leq 0.4\text{mm}$	$N \leq 4$
		$0.4\text{mm} < \varphi$	$N = 0$
	BLACK SPOT	$0.15\text{mm} \leq \varphi \leq 0.5\text{mm}$	$N \leq 4$
		$0.5\text{mm} < \varphi$	$N = 0$
	LINT	$L \leq 3\text{mm}$ $W \leq 0.1\text{mm}$	$N \leq 4$
$3\text{mm} < L$		$N = 0$	
NEWTON RINGS		NOT ALLOWED	
ELECTRICAL DEFECT	BRIGHT DOT	$N \leq 8$ (Green:5)	
	DARK DOT	$N \leq 8$	
	TOTAL DOT	$N \leq 10$	
	TWO ADJACENT DOT BRIGHT DOT DARK DOT	$\leq 2$ PAIRS $\leq 2$ PAIRS	
	THREE OR MORE ADJACENT DOT	NOT ALLOWED	
	DISTANCE BETWEEN DEFECTS BRIGHT DOT DARK DOT	$\geq 15\text{mm}$ $\geq 15\text{mm}$	
	LINE DEFECT	NOT ALLOWED	

\*1)W:width ,L:Lenth ,D:number

\*2) DEFINITION OF ADJACENT

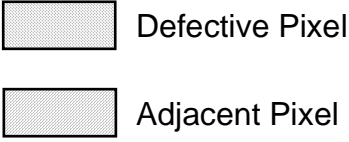
R	G	B	R	G	B	R	G	B	
R	G	B	R	G	B	R	G	B	
R	G	B	R	G	B	R	G	B	

The defects that are not defined above and considered to be problem shall be reviewed and discussed by both parties.

## 11. HANDLING PRECAUTIONS FOR TFT-LCD MODULE

Please pay attention to the followings in handling- TFT-LCD products;

### 1 ASSEMBLY PRECAUTION

- (1) Please use the mounting hole on the module side in installing and do not beading or wrenching LCD in assembling. And please do not drop, bend or twist LCD module in handling.
- (2) Please design display housing in accordance with the following guide lines.
  - (2.1) Housing case must be destined carefully so as not to put stresses on LCD all sides and not to wrench module. The stresses may cause non-uniformity even if there is no non-uniformity statically.
  - (2.2) Keep sufficient clearance between LCD module back surface and housing when the LCD module is mounted. Approximately 1.0 mm of the clearance in the design is recommended taking into account the tolerance of LCD module thickness and mounting structure height on the housing.
  - (2.3) When some parts, such as, FPC cable and ferrite plate, are installed underneath the LCD module, still sufficient clearance is required, such as 0.5mm. This clearance is, especially, to be reconsidered when the additional parts are implemented for EMI countermeasure.
  - (2.4) Design the inverter location and connector position carefully so as not to give stress to lamp cable, or not to interface the LCD module by the lamp cable.
  - (2.5) Keep sufficient clearance between LCD module and the others parts, such as inverter and speaker so as not to interface the LCD module. Approximately 1.0mm of the clearance in the design is recommended.
- (3) Please do not push or scratch LCD panel surface with any-thing hard. And do not soil LCD panel surface by touching with bare hands. ( Polarizer film, surface of LCD panel is easy to be flawed.)
- (4) Please do not press any parts on the rear side such as source TCP, gate TCP, control circuit board and FPCs during handling LCD module. If pressing rear part is unavoidable, handle the LCD module with care not to damage them.
- (5) Please wipe out LCD panel surface with absorbent cotton or soft cloth in case of it being soiled.
- (6) Please wipe out drops of adhesives like saliva and water on LCD panel surface immediately. They might damage to cause panel surface variation and color change.
- (7) Please do not take a LCD module to pieces and reconstruct it. Resolving and reconstructing modules may cause them not to work well.
- (8) Please do not touch metal frames with bare hands and soiled gloves. A color change of the metal frames can happen during a long preservation of soiled LCD modules.
- (9) Please pay attention to handling lead wire of backlight so that it is not tugged in connecting wit inverter.

### 2 OPERATING PRECAUTIONS

- (1) Please be sure to turn off the power supply before connecting and disconnecting signal input cable.
- (2) Please do not change variable resistance settings in LCD module. They are adjusted to the most suitable value. If they are changed, it might happen LCD does not satisfy the characteristics specification.
- (3) Please consider that LCD backlight takes longer time to become stable of radiation characteristics in low temperature than in room temperature.
- (4) A condensation might happen on the surface and inside of LCD module in case of

- sudden change of ambient temperature.
- (5) Please pay attention to displaying the same pattern for very long time. Image might stick on LCD. If then, time going on can make LCD work well.
  - (6) Please obey the same caution descriptions as ones that need to pay attention to ordinary electronic parts.

### **3 PRECAUTIONS WITH ELECTROSTATICS**

- (1) This LCD module use CMOS-IC on circuit board and TFT-LCD panel, and so it is easy to be affected by electrostatics. Please be careful with electrostatics by the way of your body connecting to the ground and so on.
- (2) Please remove protection film very slowly on the surface of LCD module to prevent from electrostatics occurrence.

### **4 STORAGE PRECAUTIONS**

- (1) When you store LCDs for a long time, it is recommended to keep the temperature between 0°C ~40°C without the exposure of sunlight and to keep the humidity less than 90%RH.
- (2) Please do not leave the LCDs in the environment of high humidity and high temperature such as 60°C 90%RH.
- (3) Please do not leave the LCDs in the environment of low temperature; below -20°C.

### **5 SAFETY PRECAUTIONS**

- (1) When you waste LCDs, it is recommended to crush damaged or unnecessary LCDs into pieces and wash them off with solvents such as acetone and ethanol, which should later be burned.
- (2) If any liquid leaks out of a damaged-glass cell and comes in contact with the hands, wash off thoroughly with soap and water.

### **6 OTHERS**

- (1) A strong incident light into LCD panel might cause display characteristics' changing inferior because of polarizer film, color filter, and other materials becoming inferior. Please do not expose LCD module direct sunlight and strong UV rays.
- (2) Please pay attention to a panel side of LCD module not to contact with other materials in preserving it alone.
- (3) For the packaging box, please pay attention to the followings:
  - (3.1) Packaging box and inner case for LCD are designed to protect the LCDs from the damage or scratching during transportation. Please do not open except picking LCDs up from the box.
  - (3.2) Please do not pile them up more than 5 boxes. (They are not designed so.) And please do not turn over.
  - (3.3) Please handle packaging box with care not to give them sudden shock and vibrations. And also please do not throw them up.
  - (3.4) Packing box and inner case for LCDs are made of cardboard. So please pay attention not to get them wet. (Such like keeping them in high humidity or wet place can occur getting them wet.)