



Chunghwa Picture Tubes, Ltd. Product Specification

To : Studio Technology Co.,Ltd

Date : 2009/02/23

TFT LCD

CLAA070NB02CT

ACCEPTED BY :

APPROVED BY	CHECKED BY	PREPARED BY
Ronald Huang	Roger Liu	Carol Shen

Prepared by :

Product Planning Management Division
Small & Medium TFT Product Business Unit
CHUNGHWA PICTURE TUBES, LTD.

1127 Hopin Rd., Padeh, Taoyuan, Taiwan 334, R.O.C.
TEL: +886-3-3675151 FAX: +886-3-377-3003

Doc.No:	CLAA070NB02CT- HAOSHENG-V1-20090223	Issue Date:	20090223
---------	-------------------------------------	-------------	----------

REVISION STATUS

Revision Notice	Description	Page	Rev. Date
V 1	First revision	--	20090211

Studio Technology Co., Ltd

CONTENTS

1. OVERVIEW	4
2. ABSOLUTE MAXIMUM RATINGS	5
3. ELECTRICAL CHARACTERISTICS	6
3.1 TFT LCD	6
3.2 TFT-LCD Power Current	7
3.3 Backlight.....	7
3.4 RSDS characteristics	7
4. INTERFACE CONNECTION	8
4.1 CN1.....	8
4.2 CN2(Backlight).....	10
4.3 Touch Panel Control	10
5. INPUT SIGNAL(DE ONLY MODE).....	11
5.1 Timing Specification	11
5.2 Timing sequence(Timing chart).....	12
5.3 Color Data Assignment.....	14
6. CHARACTERISTIC OF TOUCH PANEL	15
6.1 Basis characteristic	15
6.2 Design guideline for Touch-Panel	15
6.3 Circuit Diagram.....	15
7. BLOCK DIAGRAM	16
8. MECHANICAL DIMENSION.....	17
8.1 Front Side	17
8.2 Rear Side	17
9. OPTICAL CHARACTERISTICS	19
10. RELIABILITY TEST.....	22
10.1. Temperature and humidity.....	22
10.2. Shock and Vibration	22
10.3 Judgment standard	22

1. OVERVIEW

CLAA070NB02CT is 7" color TFT-LCD(Thin Film Transistor Liquid Crystal Display)module which integrates Touch–Screen.Composed of LCD panel,driver ICs, and LED backlight.

The 7.0"screen produces a high resolution image that is composed of 1024×600 pixel elements in a stripe arrangement.Display 262K colors by 6 Bit R.G.B signal input.

General specifications are summarized in the following table :

ITEM	SPECIFICATION
Display Area (mm)	153.6(H)×90(V)
Number of Pixels	1024(H)×3(RGB)×600(V)
Pixel Pitch (mm)	0.15(H)×0.15(V)
Color Pixel Arrangement	RGB vertical stripe
Display Mode	Normally white
Number of colors	262,144
Viewing Direction	6 o'clock
Brightness(cd/m ²)	Typ.300nit, after TSP (ILED=60 mA)
Viewing Angle(BL on,CR≥10)	140 degree(H) · 110degree(V)
Electrical Interface(data)	RSDS
Outline Dimension(in mm)	162.9(W)×102(H)×5.5(D)
Weight(g)	130g(Typ)
BL unit	LED
Surface Treatment	Anti-Glare(TSP:Glare)
Touch Panel Type	4 wire resistive

2. ABSOLUTE MAXIMUM RATINGS

Item	Symbol	Min.	Max.	Unit	Note
Digital Power Voltage	VCC	-0.5	5.0	V	
Analog Power Voltage	AVDD	-0.5	13.5	V	
Gamma Voltage	VR1~VR7	0.4AVDD	AVDD+0.3	V	
	VR6~VR14	-0.3	0.6AVDD	V	
Gate On Voltage	VDDG	-0.3	42.0	V	*1)
Gate Off Voltage	VEEG	-20.0	0.3	V	*1)
Static Electricity	VESDc	-200	200	V	*2)
	VESDm	-15KV	15KV	V	*2)
Reverse Voltage (per LED)	VR	--	5	V	
Forward Current (per LED)	If	--	30	mA	
Pulse forward current (per LED)	I _{fp}		100	mA	*4)
Operation Temperature	T _{op}	-30	85	°C	*3)
Storage Temperature	T _{stg}	-40	95	°C	*3)

Remarks :

*1) VDDG-VEEG Range : -0.3V~40V

*2) Test Condition: IEC 61000-4-2 ,

VESDc : Contact discharge to input connector

VESDm : Contact discharge to module

*3) The product must work at operation temperature range and the temperature of the panel's center point must lower than 60°C.

*4) I_{fp} Conditions : Pulse Width ≤ 10msec and Duty ≤ 1/10

3. ELECTRICAL CHARACTERISTICS

3.1 TFT LCD

Ta=25°C

Item	Symbol	Min.	Typ	Max.	Unit	Note
Digital Power Voltage	VCC	3.0	3.3	3.6	V	[Note 1] [Note 2]
Analog Power Voltage	AVDD	9.2	9.6	10.0	V	
Gate On Power Voltage	VDDG	17	18	19	V	
Gate Off Power Voltage	VEEG	-6.6	-6.0	-5.4	V	
Common Power Voltage	VCOM	2.8	3.8	4.8	V	

[Note 1] Power 、Signal sequence

Power On : VCC→AVDD/VEEG→VDDG→Data

Power Off : Data→VDDG→AVDD/VEEG→VCC

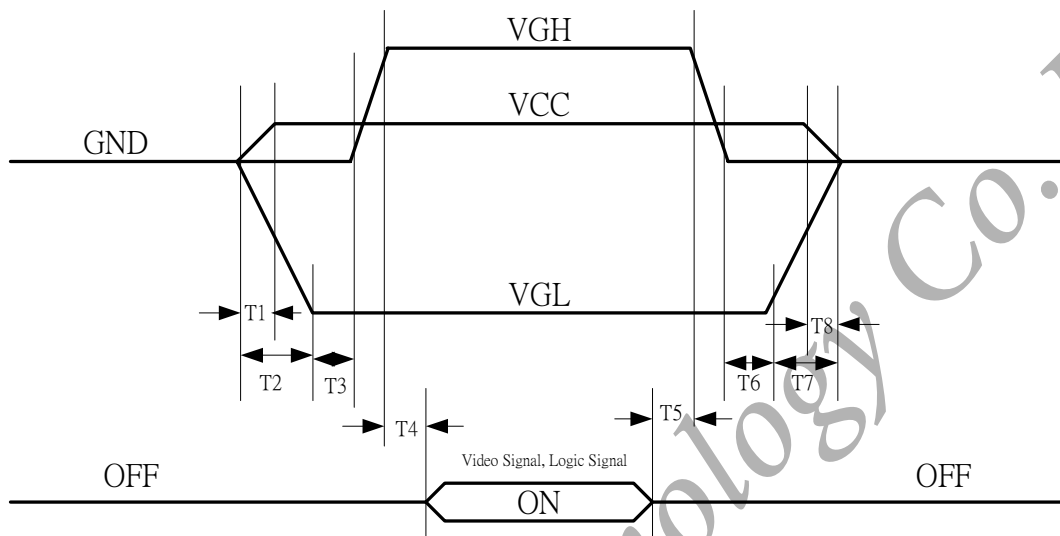

$$0 < T1 < T2 \leq 20\text{ms}$$

$$T3 \leq 10\text{ms}$$

$$T4 \leq 10\text{ms}$$

$$T5 \leq 10\text{ms}$$

$$T6 \leq 10\text{ms}$$

$$T8 < T7 \leq 10\text{ms}$$

[Note 2] Common Power Voltage propose to electrical charateristics of power voltage.

3.2 TFT-LCD Power Current

Item	Symbol	Condition	Min	Typ	Max	Unit	Remark
Digital Power Current	IVCC	VCC= 3.3V	-	8	15	mA	
Analog Power Current	IAVDD	AVDD= 9.6V	-	40	50	mA	
Gate on Power Current	IVDDG	VDDG=18V	-	0.5	1	mA	
Gate off Power Current	IVEEG	VEEG=-6V	-	0.5	1	mA	

3.3 Backlight

Ta=25°C

Item	Symbol	Min	Typ	Max	Unit	Remark
LED Voltage	VLED	21	22.75	24.5	V	For LED Backlight
LED Current	ILED	--	60	--	mA	For LED Backlight
Power consumption	WL	--	1.365	--	W	

*1) : We suggest using the constant current control, IL=60mA, to avoid the leakage light and brightness quality issue.

3.4 RSDS characteristics

Item	Symbol	Min	Typ	Max	Unit	Condition
RSDS High Input Voltage	VIHRSDS	100	200	-	mV	VCMRSDS = + 1.2 V
RSDS Low Input Voltage	VILRSDS	-	- 200	- 100	mV	VCMRSDS = + 1.2 V
VCM RSDS	VCMRSDS	GND+0.1	1.2	VCC-1.2	V	Note1

Notes:

1. $VCMRSDS = (VIHRSDS + VILRSDS) / 2$

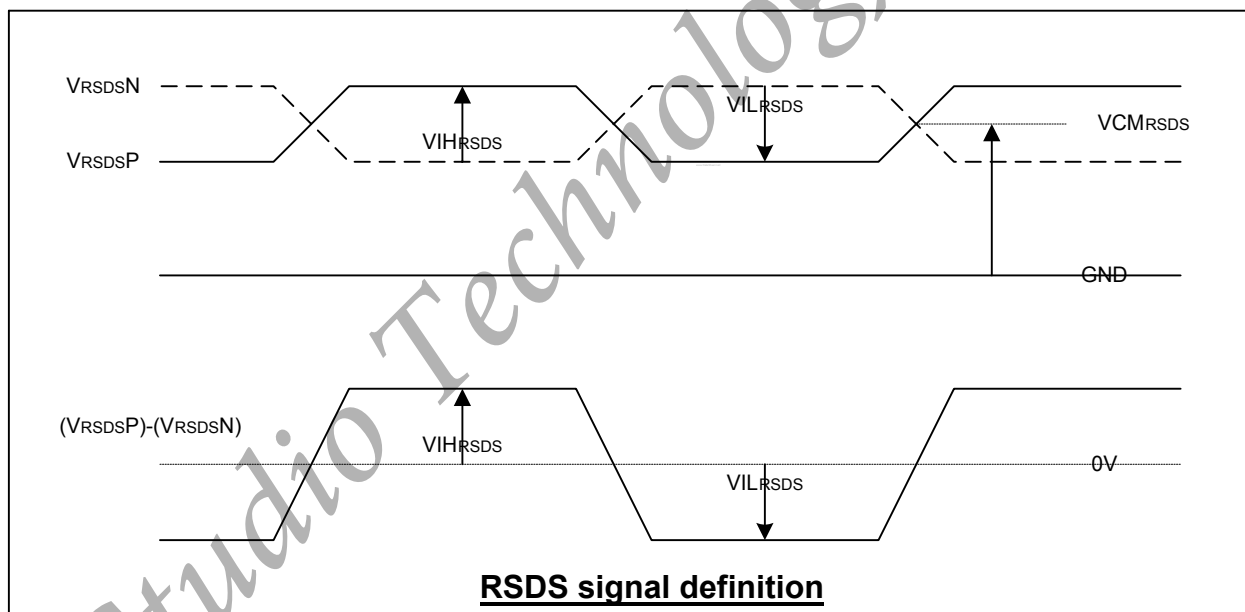

4. INTERFACE CONNECTION

4.1 CN1

PIN NO.	Symbol	Function
1	VCOM	Voltage applied to color filter substrate
2	DIO1	Start pulse signal I/O
3	VCC	Power Supply for Digital circuit
4	CLKP	Positive RSDS differential clock
5	CLKN	Negative RSDS differential clock
6	SHL	Select left/right shift
7	R0N	Negative RSDS data
8	R0P	Positive RSDS data
9	R1N	Negative RSDS data
10	R1P	Positive RSDS data
11	R2N	Negative RSDS data
12	R2P	Positive RSDS data
13	G0N	Negative RSDS data
14	G0P	Positive RSDS data
15	G1N	Negative RSDS data
16	G1P	Positive RSDS data
17	G2N	Negative RSDS data
18	G2P	Positive RSDS data
19	AVDD	Power Supply for Analog circuit
20	VR1	Gamma voltage level 1
21	VR 2	Gamma voltage level 2
22	VR 3	Gamma voltage level 3
23	VR 4	Gamma voltage level 4
24	VR 5	Gamma voltage level 5
25	VR 6	Gamma voltage level 6
26	VR 7	Gamma voltage level 7
27	VR 8	Gamma voltage level 8
28	VR 9	Gamma voltage level 9
29	VR 10	Gamma voltage level 10
30	VR 11	Gamma voltage level 11
31	VR 12	Gamma voltage level 12
32	VR 13	Gamma voltage level 13
33	VR 14	Gamma voltage level 14
34	AVSS	Power Ground for Analog circuit
35	B0N	Negative RSDS data
36	B0P	Positive RSDS data
37	B1N	Negative RSDS data
38	B1P	Positive RSDS data
39	B2N	Negative RSDS data
40	B2P	Positive RSDS data
41	LD	Latch the polarity of output and switch the new data to output
42	POL	Polarity selection

43	GND	Power Ground
44	DIO2	Start pulse signal I/O
45	NC	NC
46	NC	NC
47	NC	NC
48	NC	NC
49	NC	NC
50	NC	NC
51	NC	NC
52	XON	Control driver output enable or disable
53	OEV	Gate driver output enable
54	UD	Up/ Down control pin
55	VCLK	Vertical clock
56	STVU	Vertical start pulse signal I/O
57	STVD	Vertical start pulse signal I/O
58	VDDG	Gate driver positive voltage
59	VEEG	Gate driver negative voltage
60	VCC	Power Supply for Digital circuit
61	GND	Power Ground

Studio Technology Co., Ltd.

Remarks :

1) GND /AVSS Pin must ground contact , can not be floating.

2) SHL : Select left or right

SHL	DIO1	DIO2	SHIFT
1	Input	Output	Right
0	Output	Input	Left

3) UD : Shift up or down control

UD	STVD	STVU	SHIFT
1	Input	Output	UP
0	Output	Input	Down

4.2 CN2(Backlight)

Pin No.	Function
1	+
2	-
3	-
4	-
5	Dummy
6	
7	
8	

4.3 Touch Panel Control

Pin No.	Symbol	Function
1	YU	Y axis resistance
2		
3	XR	X axis resistance
4		
5	YD	Y axis resistance
6		
7	XL	X axis resistance
8		

5. INPUT SIGNAL(DE ONLY MODE)

5.1 Timing Specification

5.1.1 Horizontal Timing Specification

ITEM	SYMBLE	SPECIFICATION			UNIT
		Min	Typ	Max	
CLK frequency	Fclk	-	45	47	MHz
CLK pulse width	Tcw	40%	-	60%	CLKP period
DATA set-up time	Tsu	4	-	-	ns
DATA hold time	Thd	2	-	-	ns
STH set-up time	Tsu	4	-	-	ns
STH hold time	Thd	2	-	-	ns
Propagation delay of STH	Tphl	6	10	15	ns
Time that the last data to LP	Tkl	1	-	-	CLKP period
LP pulse width	Twd	2	-	-	CLKP period
Time that LD to STH	Tlds	5	-	-	CLKP period
POL set-up time	Tpsu	6	-	-	ns
POL hold time	Tphd	6	-	-	ns

5.1.2 Vertical Timing Specification

ITEM	SYMBOL	SPECIFICATION			UNIT
		Min	Typ	Max	
VCLK Frequency	Fvclk	-	37.5	-	Khz
Clock pulse width (High & Low)	PWCLK	2.5	-	-	us
STVD/STVU Set-up Time	Tsu	700	-	-	ns
STVD/STVU Hold Time	Thd	700	-	-	ns
OE Pulse Width	Twc1	1	-	-	us

5.2 Timing sequence(Timing chart)

5.2.1 Horizontal Timing Sequence

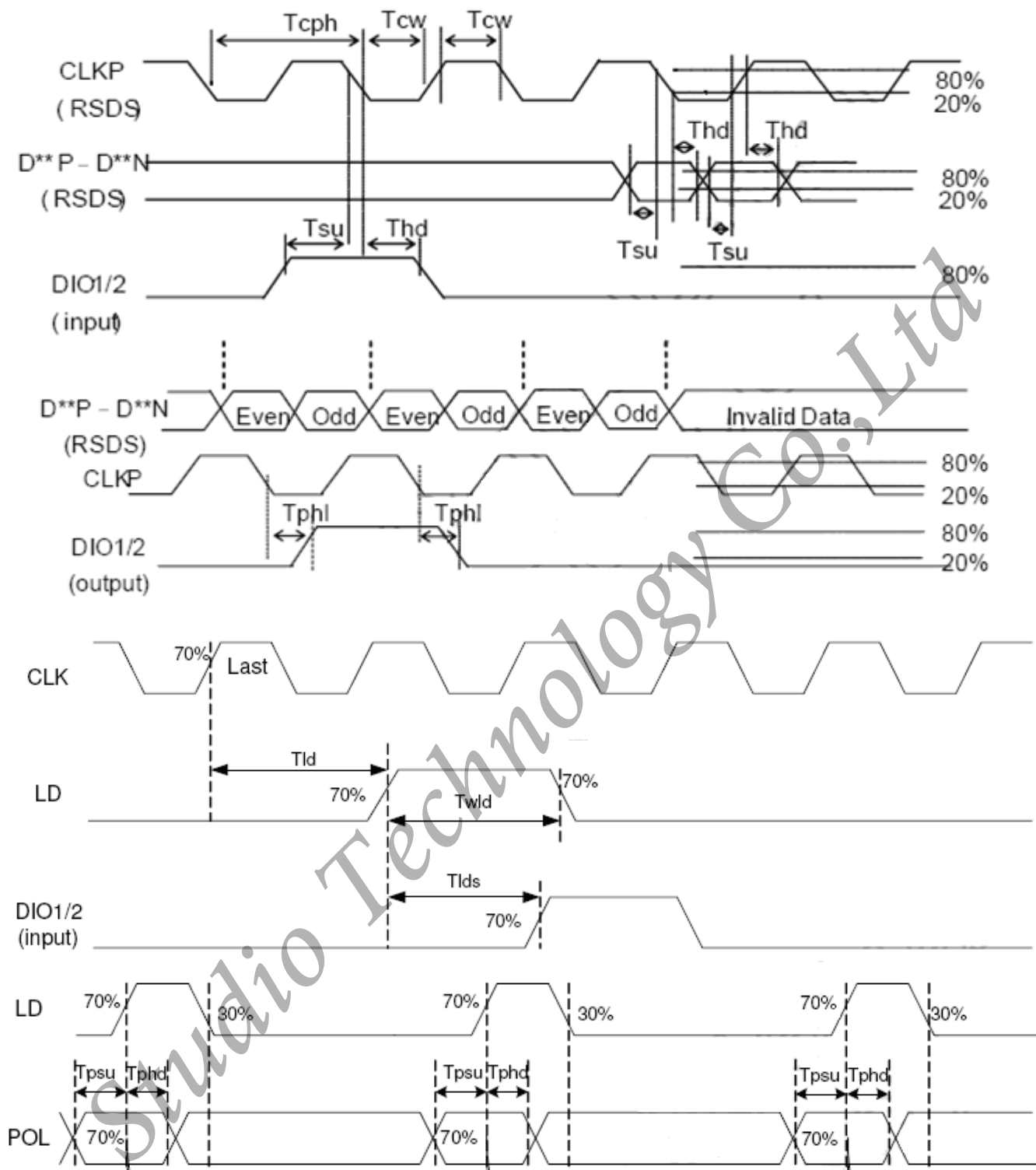

5.2.2 Vertical Timing Sequence

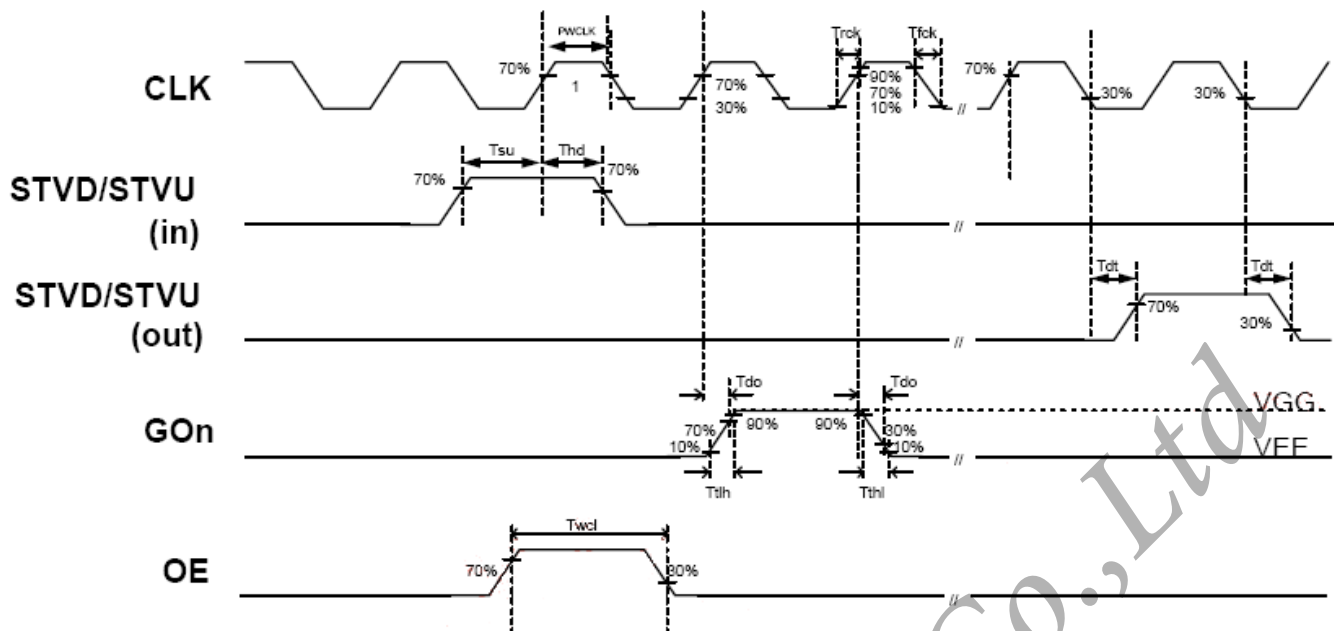

Studio Technology Co., Ltd.

5.3 Color Data Assignment

COLOR	INPUT DATA	R DATA						G DATA						B DATA					
		R5	R4	R3	R2	R1	R0	G5	G4	G3	G2	G1	G0	B5	B4	B3	B2	B1	B0
		MSB					LSB	MSB					LSB	MSB					LSB
BASIC COLOR	BLACK	0	0	0	0	0	0	0	0	0	0	0	0	0	0	0	0	0	0
	RED(63)	1	1	1	1	1	1	0	0	0	0	0	0	0	0	0	0	0	0
	GREEN(63)	0	0	0	0	0	0	1	1	1	1	1	1	0	0	0	0	0	0
	BLUE(63)	0	0	0	0	0	0	0	0	0	0	0	0	1	1	1	1	1	1
	CYAN	0	0	0	0	0	0	1	1	1	1	1	1	1	1	1	1	1	1
	MAGENTA	1	1	1	1	1	1	0	0	0	0	0	0	1	1	1	1	1	1
	YELLOW	1	1	1	1	1	1	1	1	1	1	1	1	0	0	0	0	0	0
	WHITE	1	1	1	1	1	1	1	1	1	1	1	1	1	1	1	1	1	1
RED	RED(0)	0	0	0	0	0	0	0	0	0	0	0	0	0	0	0	0	0	0
	RED(1)	0	0	0	0	0	1	0	0	0	0	0	0	0	0	0	0	0	0
	RED(2)	0	0	0	0	1	0	0	0	0	0	0	0	0	0	0	0	0	0
	RED(62)	1	1	1	1	1	0	0	0	0	0	0	0	0	0	0	0	0	0
	RED(63)	1	1	1	1	1	1	0	0	0	0	0	0	0	0	0	0	0	0
GREEN	GREEN(0)	0	0	0	0	0	0	0	0	0	0	0	0	0	0	0	0	0	0
	GREEN(1)	0	0	0	0	0	0	0	0	0	0	0	1	0	0	0	0	0	0
	GREEN(2)	0	0	0	0	0	0	0	0	0	0	1	0	0	0	0	0	0	0
	GREEN(62)	0	0	0	0	0	0	1	1	1	1	1	0	0	0	0	0	0	0
	GREEN(63)	0	0	0	0	0	0	1	1	1	1	1	1	0	0	0	0	0	0
BLUE	BLUE(0)	0	0	0	0	0	0	0	0	0	0	0	0	0	0	0	0	0	0
	BLUE(1)	0	0	0	0	0	0	0	0	0	0	0	0	0	0	0	0	0	1
	BLUE(2)	0	0	0	0	0	0	0	0	0	0	0	0	0	0	0	0	1	0
	BLUE(62)	0	0	0	0	0	0	0	0	0	0	0	0	1	1	1	1	1	0
	BLUE(63)	0	0	0	0	0	0	0	0	0	0	0	0	1	1	1	1	1	1

Remarks :

(1) Definition of Gray Scale

color(n) : n is series of Gray Scale

The more n value is, the bright Gray Scale.

(2)Data:1-High,0-Low

6. CHARACTERISTIC OF TOUCH PANEL

6.1 Basis characteristic

Item	Standard	Note
Operating Voltage	3V(Min)/5V(Typ)/7V(Max)	DC
Surface Treatment	Glare , Anti-NR , Hardness : 3H	
Activation Force	Max. 100gf	Less than 100gf individual with stylus pen (R 0.8mm) or finger (R 8.0mm)
Interface Type	4 Wire Resistive	
Resistance Between Terminals	X(Film side) : 200~900Ω Y(Glass side) : 200~900Ω	At the connector
Linearity	X(Film side) : $\leq 1.5\%$ Y(Glass side) : $\leq 1.5\%$	Testing interval is 5mm with load 120g
Insulation Resistance	Min. 20MΩ	At DC 25V

6.2 Design guideline for Touch-Panel

- The Housing Cushion on touch-panel must be set at outside of T.P's view-area .
- The Cushion material must be elastic material.
- The housing must avoid to touch the T.P
- To combine, the housing should not be stuck on T.P.
- Only the active area(AA) is guaranteed the position data detectable precision and other operations work.
- Example of housing design :

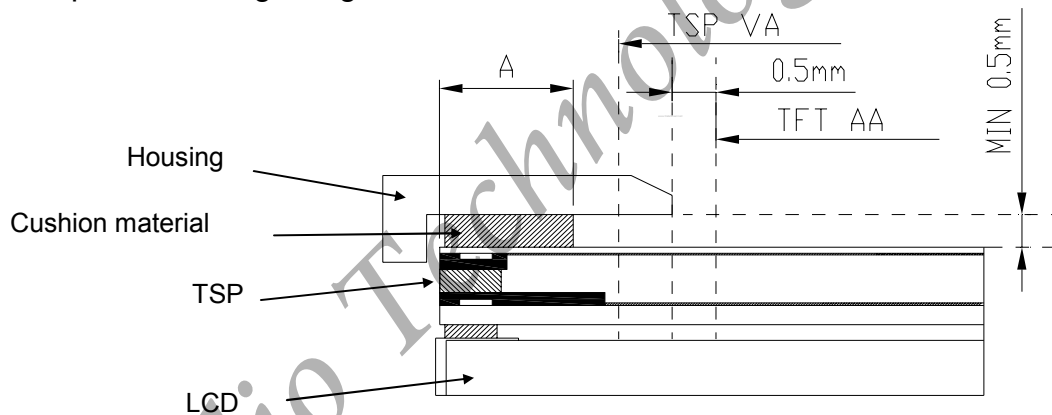

6.3 Circuit Diagram

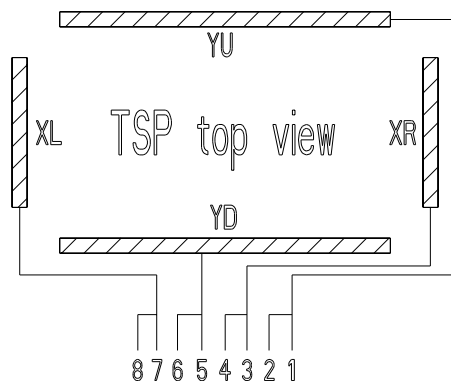

7. BLOCK DIAGRAM

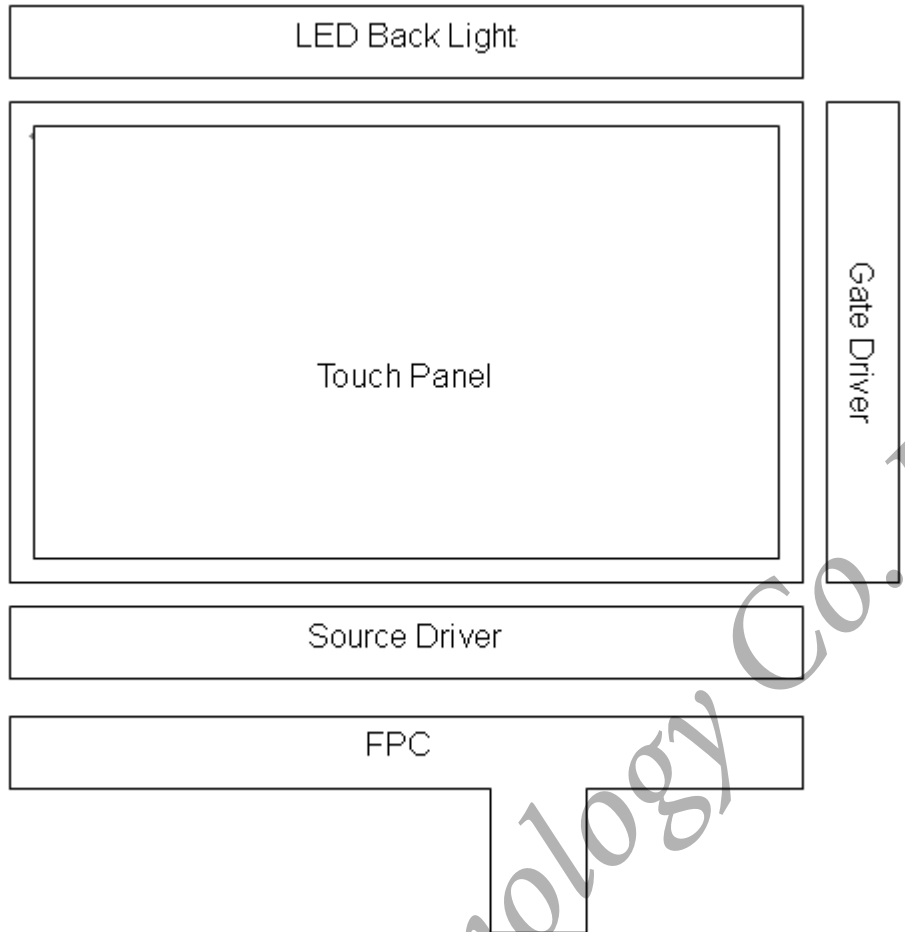

Studio Technology Co., Ltd

8. MECHANICAL DIMENSION

8.1 Front Side

[Unit : mm]

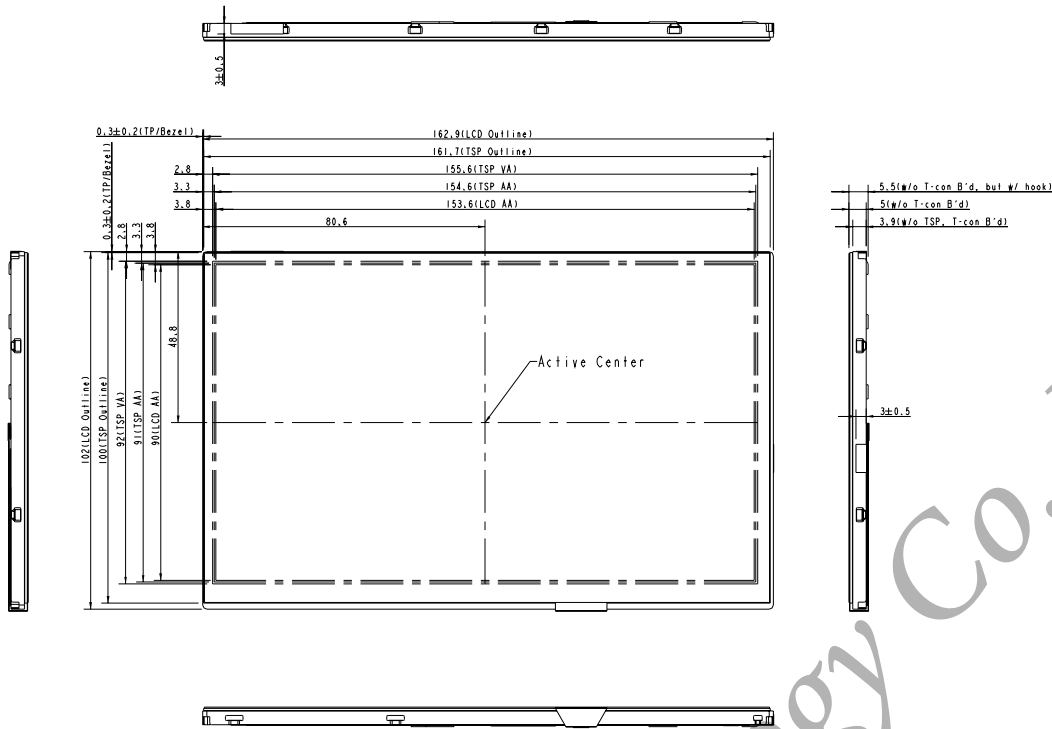

General Tolerance ±0.3 mm

8.2 Rear Side

[Unit : mm]

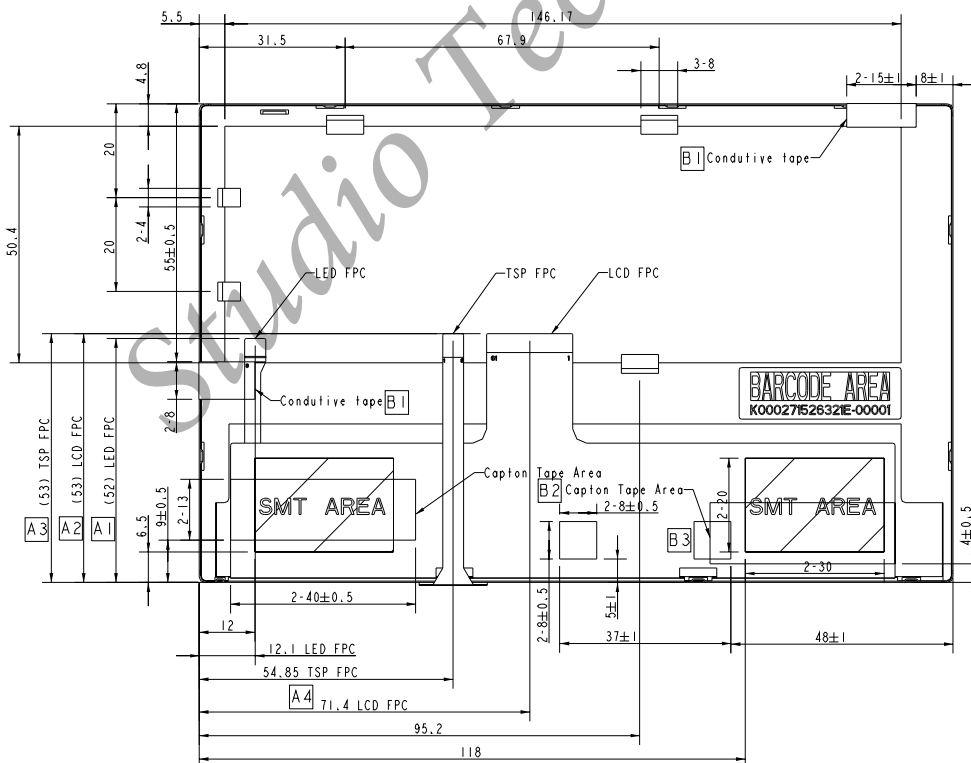

General Tolerance ±0.5 mm

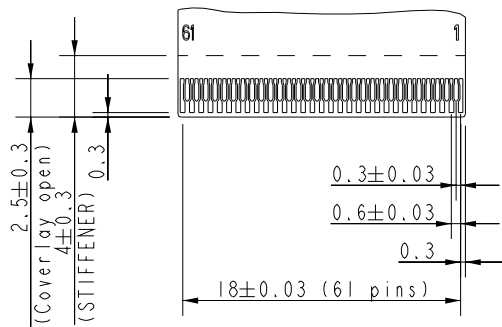

LCD FPC DETAIL

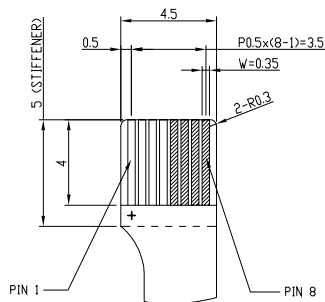

Pin 1 : positive +
 Pin 2~4 : negative -
 Pin 5~8 : dummy pin
 21pcs LED (for 1 BL)

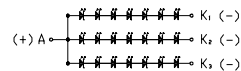

LED FPC DETAIL

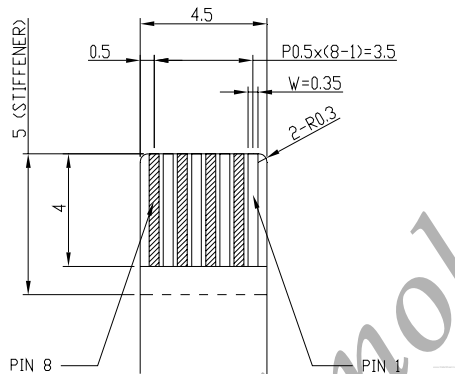

PIN No.	Assignment
1	
2	YU
3	
4	XR
5	
6	YD
7	
8	XL

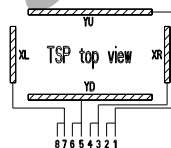

TSP FPC DETAIL

9. OPTICAL CHARACTERISTICS

Item		Symbol	Condition	Min.	Typ.	Max.	Unit	Remarks
Constrast Ratio		CR	Point-5	300	400	--	--	*1)*2)*3)
Luminance*)		Lw	Point-5	240	300	--	cd/m ²	*1)*3)
Luminance Uniformity		ΔL		70	80	--	%	*1)*3)
Response Time (White - Black)		Tr+ Tf	Point-5	--	20	30	ms	*1)*3)*5)
Viewing Angle	Horizontal	ϕ	CR \geq 10 Point-5	120	140	--	°	*1)*2)*4)
	Vertical	θ		100	120	--	°	*1)*2)*4)
Color Coordinate	White	Wx Wy	Point-5	0.273 0.289	0.313 0.329	0.353 0.369	*1)*3)	*1)*3)
	Red	Rx Ry		0.544 0.305	0.584 0.345	0.624 0.385		
	Green	Gx Gy		0.300 0.515	0.340 0.555	0.390 0.595		
	Blue	Bx By		0.108 0.090	0.148 0.130	0.188 0.170		

Remarks :

*1)Measure condition : 25°C \pm 2°C , 60 \pm 10%RH , under10 Lux in the dark room.BM-5A (TOPCON) , viewing angle2° , VCC=3.3V , VDD=5V. ILED=60mA

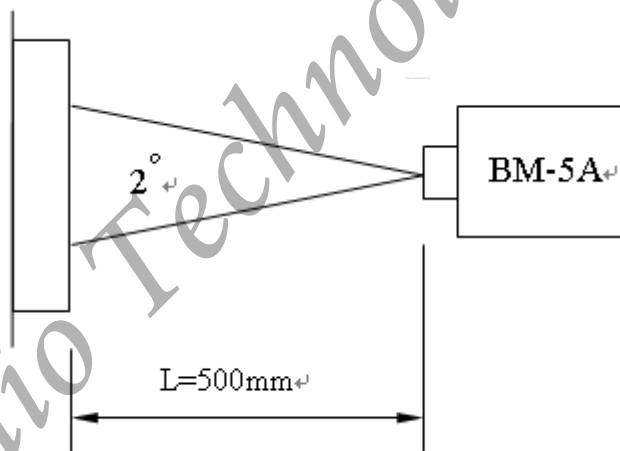

*2) Definition of contrast ratio :

$$\text{Contrast Ratio (CR)} = (\text{White}) \text{ Luminance of ON} \div (\text{Black}) \text{ Luminance of OFF}$$

*3) Definition of luminance :

Measure white luminance on the point 5 as figure9-1

Definition of Luminance Uniformity:

Measure white luminance on the point1~9as figure9-1

$$\Delta L = [L(\text{MIN})/L(\text{MAX})] \times 100$$

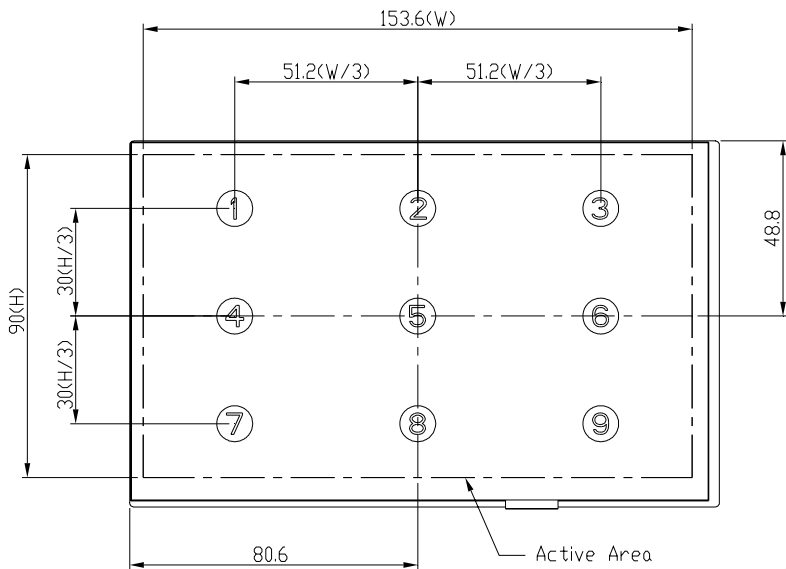

Fig9-1 Measuring point

*4) Definition of Viewing Angle(θ, ψ), refer to Fig9-2 as below :

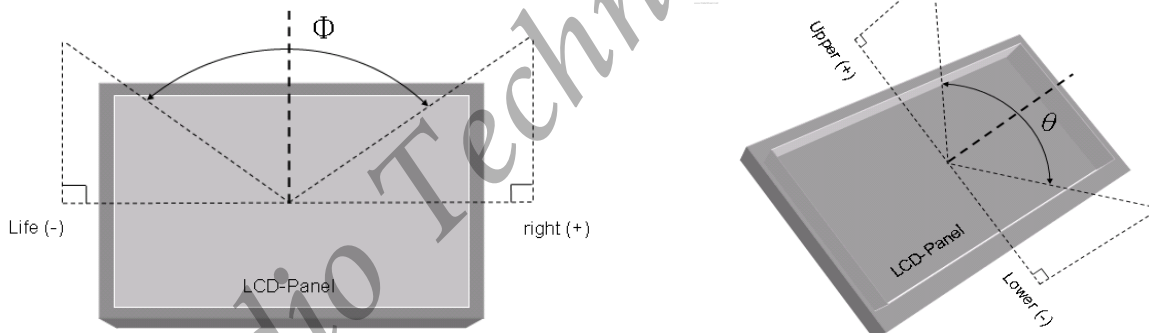

Fig9-2 Definition of Viewing Angle

*5) Definition of Response Time.(White-Black)

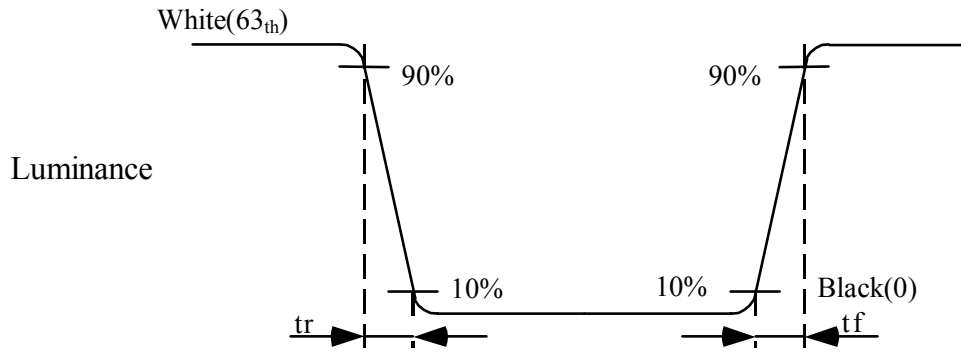

Fig9-3 Definition of Response Time(White-Black)

Studio Technology Co., Ltd

10. RELIABILITY TEST

10.1. Temperature and humidity

TEST ITEMS	CONDITIONS	REMARK
High Temperature Operation	85°C , 240Hrs	
High Temperature Storage	95°C , 240Hrs	
High Temperature High Humidity Operation	60°C , 90%RH , 240Hrs	No condensation
Low Temperature Operation	-30°C , 240Hrs	
Low Temperature Storage	-40°C , 240Hrs	
Thermal Shock	-30°C (0.5Hr) ~ 85°C(0.5Hr) 200 cycles	

10.2. Shock and Vibration

TEST ITEMS	CONDITIONS
Shock (Non-operation)	<ul style="list-style-type: none"> ● Shock level:980m/s²(equal to 100G) ● Waveform:half sinusoidal wave,6ms. ● Number of shocks:one shock input in each direction of three mutually perpendicular axes for a total of three shock inputs.
Vibration (Non-operation)	<ul style="list-style-type: none"> ● Frequency range:8~33.3Hz ● Stoke:1.3mm ● Vibration: sinusoidal wave, perpendicular axis(both x, z axis:2Hrs,y axis:4Hrs). ● Sweep:2.9G,33.3Hz-400Hz ● Cycle:15min

10.3 Judgment standard

The Judgment of the above test should be made as follow:

Pass:Normal display image with no obvious non-uniformity and no line defect.Partial trasformation of the module parts should be ignored.

Fail:No display image,obvious non-uniformity,or line defect.