

FEATURES

- This type with height 2.1mm Max.
- Small mounting area of 23.4mm².
- SMD type suitable for automatic & high density surface mounting.
- Plastic mold package containing highly reliable tubular type quartz crystal.
- Excellent shock and heat resistance.

APPLICATIONS

- Cellular Phones, Pagers, Radio Communication Equipment, Portable Applications etc.

STANDARD SPECIFICATION

Conditions without notice (Temperature: +25°C±2°C)

Item	Symbol	Specification	Conditions / Note
Nominal Frequency	f ₀	32.768kHz	
Frequency Tolerance	Δf/f ₀	±20ppm	Can be used in high accurate products
Turnover Temperature	T _p	+25°C±5°C	
Temperature Coefficient	K	(-3.5±0.8) × 10 ⁻⁸ /°C ²	
Load Capacitance	C _L	12.5pF	
Equivalent Series Resistance	R ₁	50k max.	
Maximum Drive Level	DL _{max}	1μW	
Drive Level	DL	0.1μW	
Shunt Capacitance	C ₀	0.9pF typ	
Aging	Δf/f ₀	±3ppm max.	+25°C±3°C, First Year
Operating Temperature Range	T _{ope}	-20°C~+70°C	
Storage Temperature Range	T _{sto}	-40°C~+125°C	
Reflow Profile	T _{sol}	230°C max. 20sec. x 2 times	IR Reflow

DIMENSIONS (For details, please refer to individual specification)

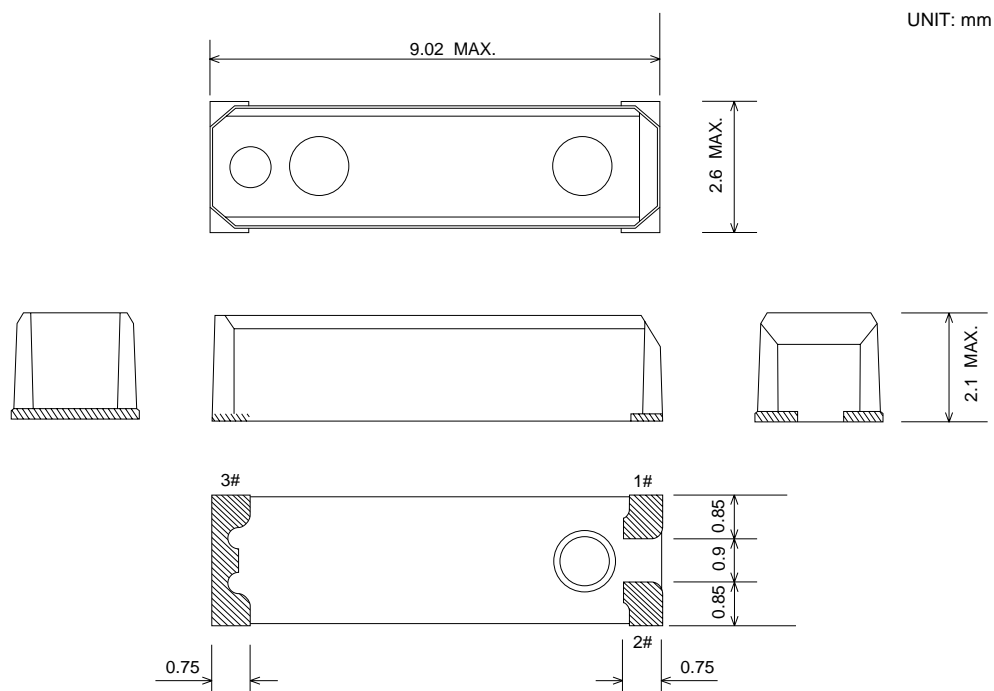

LEAD CONNECTION

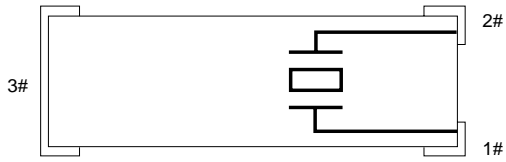

TERMINAL LAND AREA

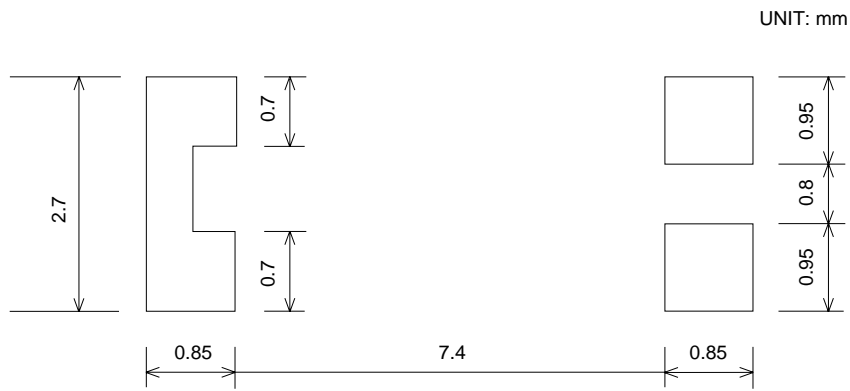

Note: Please make sure that there is no electric wire line under SSP-T5 on the circuit board.