

# DDR2 SDRAM UNBUFFERED DIMM

MT16HTF6464A – 512MB  
MT16HTF12864A – 1GB (PRELIMINARY<sup>†</sup>)  
MT16HTF25664A – 2GB (PRELIMINARY<sup>†</sup>)

For the latest data sheet, please refer to the Micron® Web site: [www.micron.com/products/modules](http://www.micron.com/products/modules)

## Features

- 240-pin, unbuffered dual in-line memory module (UDIMM)
- Fast data transfer rates: PC2-3200 or PC2-4200
- Utilizes 400 MT/s and 533 MT/s DDR2 SDRAM components
- 512MB (64 Meg x 64), 1GB (128 Meg x 64) 2GB (256 Meg x 64)
- VDD = VDDQ = +1.8V
- VDDSPD = +1.7V to +3.6V
- JEDEC standard 1.8V I/O (SSTL\_18-compatible)
- Differential data strobe (DQS, DQS#) option
- Four-bit prefetch architecture
- DLL to align DQ and DQS transitions with CK
- Multiple internal device banks for concurrent operation
- Programmable CAS# latency (CL): 3 and 4
- Posted CAS# additive latency (AL): 0, 1, 2, 3, and 4
- WRITE latency = READ latency - 1<sup>t</sup>CK
- Programmable burst lengths: 4 or 8
- Adjustable data-output drive strength
- 64ms, 8,192-cycle refresh
- On-die termination (ODT)
- Serial Presence Detect (SPD) with EEPROM
- Gold edge contacts

Figure 1: 240-Pin DIMM (MO-237 R/C “B”)

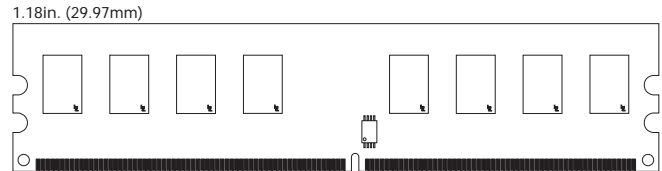

## OPTIONS

- Package
  - 240-pin DIMM (standard)
  - 240-pin DIMM (lead-free)<sup>1</sup>
- Frequency/CAS Latency<sup>2</sup>
  - 3.75ns @ CL = 4 (DDR2-533)
  - 5.0ns @ CL = 3 (DDR2-400)
- PCB
  - 1.18in. (29.97mm)

## MARKING

- |  |      |
|--|------|
|  | G    |
|  | Y    |
|  | -53E |
|  | -40E |

NOTE: 1. Consult factory for availability of lead-free products.  
2. CL = CAS (READ) Latency.

Table 1: Address Table

	512MB	1GB	2GB
Refresh Count	8K	8K	8K
Row Addressing	8K (A0–A12)	16K (A0–A13)	16K (A0–A13)
Device Bank Addressing	4 (BA0, BA1)	4 (BA0, BA1)	8 (BA0, BA1, BA2)
Device Page Size per Bank	1KB	1KB	1KB
Device Configuration	256Mb (32 Meg x 8)	512Mb (64 Meg x 8)	1Gb (128 Meg x 8)
Column Addressing	1K (A0–A9)	1K (A0–A9)	1K (A0–A9)
Module Rank Addressing	2 (S0#, S1#)	2 (S0#, S1#)	2 (S0#, S1#)



**Table 2: Key Timing Parameters**

SPEED GRADE	DATA RATE (MHz)		t <sub>RCD</sub> (ns)	t <sub>RP</sub> (ns)	t <sub>RC</sub> (ns)
	CL = 3	CL = 4			
-53E	400	533	15	15	60
-40E	400	400	15	15	55

**Table 3: Part Numbers and Timing Parameters**

PART NUMBER <sup>1</sup>	MODULE DENSITY	CONFIGURATION	MODULE BANDWIDTH	MEMORY CLOCK/ DATA RATE	LATENCY (CL - t <sub>RCD</sub> - t <sub>RP</sub> )
MT16HTF6464AG-40E__	512MB	64 Meg x 64	3.2 GB/s	5.0ns/400 MT/s	3-3-3
MT16HTF6464AY-40E__	512MB	64 Meg x 64	3.2 GB/s	5.0ns/400 MT/s	3-3-3
MT16HTF6464AG-53E__	512MB	64 Meg x 64	4.3 GB/s	3.75ns/533 MT/s	4-4-4
MT16HTF6464AY-53E__	512MB	64 Meg x 64	4.3 GB/s	3.75ns/533 MT/s	4-4-4
MT16HTF12864AY-40E__ <sup>2</sup>	1GB	128 Meg x 64	3.2 GB/s	5.0ns/400 MT/s	3-3-3
MT16HTF12864AY-53E__ <sup>2</sup>	1GB	128 Meg x 64	4.3 GB/s	3.75ns/533 MT/s	4-4-4
MT16HTF25664AY-40E__ <sup>2</sup>	2GB	256 Meg x 64	3.2 GB/s	5.0ns/400 MT/s	3-3-3
MT16HTF25664AY-53E__ <sup>2</sup>	2GB	256 Meg x 64	4.3 GB/s	3.75ns/533 MT/s	4-4-4

NOTE:

1. All part numbers end with a two-place code (not shown), designating component and PCB revisions. Consult factory for current revision codes. Example: MT16HTF12864AG-40EC2.
2. Contact Micron for product availability.

**Table 4: Pin Assignment (240-pin DIMM Front)**

PIN	SYMBOL	PIN	SYMBOL	PIN	SYMBOL	PIN	SYMBOL
1	VREF	31	DQ19	61	A4	91	Vss
2	Vss	32	Vss	62	VDDQ	92	DQS5#
3	DQ0	33	DQ24	63	A2	93	DQS5
4	DQ1	34	DQ25	64	VDD	94	Vss
5	Vss	35	Vss	65	Vss	95	DQ42
6	DQS0#	36	DQS3#	66	Vss	96	DQ43
7	DQS0	37	DQS3	67	VDD	97	Vss
8	Vss	38	Vss	68	NC	98	DQ48
9	DQ2	39	DQ26	69	VDD	99	DQ49
10	DQ3	40	DQ27	70	A10/AP	100	Vss
11	Vss	41	Vss	71	BA0	101	SA2
12	DQ8	42	NC	72	VDDQ	102	NC
13	DQ9	43	NC	73	WE#	103	Vss
14	Vss	44	Vss	74	CAS#	104	DQS6#
15	DQS1#	45	NC	75	VDDQ	105	DQS6
16	DQS1	46	NC	76	S1#	106	Vss
17	Vss	47	Vss	77	ODT1	107	DQ50
18	NC	48	NC	78	VDDQ	108	DQ51
19	NC	49	NC	79	Vss	109	Vss
20	Vss	50	Vss	80	DQ32	110	DQ56
21	DQ10	51	VDDQ	81	DQ33	111	DQ57
22	DQ11	52	CKE0	82	Vss	112	Vss
23	Vss	53	VDD	83	DQS4#	113	DQS7#
24	DQ16	54	NC/BA2	84	DQS4	114	DQS7
25	DQ17	55	NC	85	Vss	115	Vss
26	Vss	56	VDDQ	86	DQ34	116	DQ58
27	DQS2#	57	A11	87	DQ35	117	DQ59
28	DQS2	58	A7	88	Vss	118	Vss
29	Vss	59	VDD	89	DQ40	119	SDA
30	DQ18	60	A5	90	DQ41	120	SCL

**Table 5: Pin Assignment (240-pin DIMM Back)**

PIN	SYMBOL	PIN	SYMBOL	PIN	SYMBOL	PIN	SYMBOL
121	Vss	151	Vss	181	VDDQ	211	DM5
122	DQ4	152	DQ28	182	A3	212	NC
123	DQ5	153	DQ29	183	A1	213	Vss
124	Vss	154	Vss	184	VDD	214	DQ46
125	DM0	155	DM3	185	CK0	215	DQ47
126	NC	156	NC	186	CK0#	216	Vss
127	Vss	157	Vss	187	VDD	217	DQ52
128	DQ6	158	DQ30	188	A0	218	DQ53
129	DQ7	159	DQ31	189	VDD	219	Vss
130	Vss	160	Vss	190	BA1	220	CK2
131	DQ12	161	NC	191	VDDQ	221	CK2#
132	DQ13	162	NC	192	RAS#	222	Vss
133	Vss	163	Vss	193	S0#	223	DM6
134	DM1	164	DM8	194	VDDQ	224	NC
135	NC	165	NC	195	ODT0	225	Vss
136	Vss	166	Vss	196	NC/A13	226	DQ54
137	CK1	167	NC	197	VDD	227	DQ55
138	CK1#	168	NC	198	Vss	228	Vss
139	Vss	169	Vss	199	DQ36	229	DQ60
140	DQ14	170	VDDQ	200	DQ37	230	DQ61
141	DQ15	171	CKE1	201	Vss	231	Vss
142	Vss	172	VDD	202	DM4	232	DM7
143	DQ20	173	NC	203	NC	233	NC
144	DQ21	174	NC	204	Vss	234	Vss
145	Vss	175	VDDQ	205	DQ38	235	DQ62
146	DM2	176	A12	206	DQ39	236	DQ63
147	NC	177	A9	207	Vss	237	Vss
148	Vss	178	VDD	208	DQ44	238	VDDSPD
149	DQ22	179	A8	209	DQ45	239	SA0
150	DQ23	180	A6	210	Vss	240	SA1

NOTE:

Pin 196 is NC for 512MB, or A13 for 1GB and 2GB; pin 54 is NC for 512MB and 1GB, or BA2 for 2GB.

**Figure 2: Pin Locations**

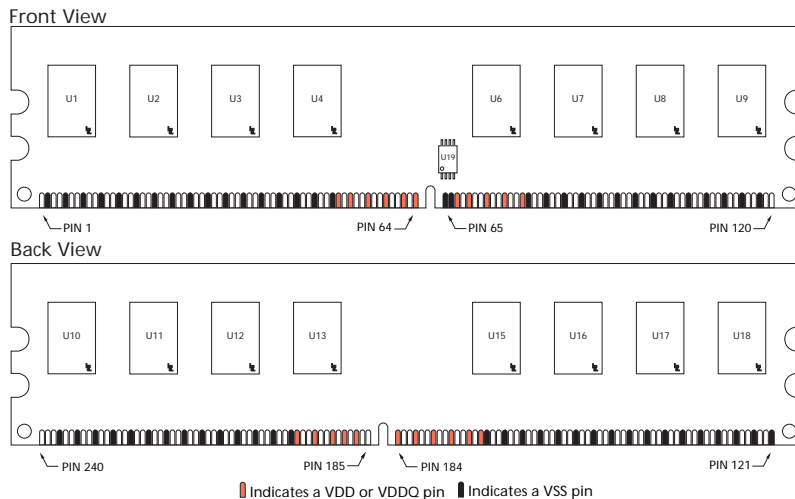

**Table 6: Pin Descriptions**

Pin numbers may not correlate with symbols; refer to Pin Assignment tables on page 3 for more information

PIN NUMBERS	SYMBOL	TYPE	DESCRIPTION
77, 195	ODT0, ODT1	Input	On-Die Termination: ODT (registered HIGH) enables termination resistance internal to the DDR2 SDRAM. When enabled, ODT is only applied to each of the following pins: DQ, DQS, DQS#, and DM. The ODT input will be ignored if disabled via the LOAD MODE command.
137, 138, 185, 186, 220, 221	CK0, CK0#, CK1, CK1#, CK2, CK2#	Input	Clock: CK and CK# are differential clock inputs. All address and control input signals are sampled on the crossing of the positive edge of CK and negative edge of CK#. Output data (DQs and DQS/DQS#) is referenced to the crossings of CK and CK#.
52, 171	CKE0, CKE1	Input	Clock Enable: CKE (registered HIGH) activates and CKE (registered LOW) deactivates clocking circuitry on the DDR2 SDRAM. The specific circuitry that is enabled/disabled is dependent on the DDR2 SDRAM configuration and operating mode. CKE LOW provides PRECHARGE POWER-DOWN and SELF REFRESH operations (all device banks idle), or ACTIVE POWER-DOWN (row ACTIVE in any device bank). CKE is synchronous for POWER-DOWN entry, POWER-DOWN exit, output disable, and for SELF REFRESH entry. CKE is asynchronous for SELF REFRESH exit. Input buffers (excluding CK, CK#, CKE, and ODT) are disabled during POWER-DOWN. Input buffers (excluding CKE) are disabled during SELF REFRESH. CKE is an SSTL_18 input but will detect a LVCMOS LOW level once VDD is applied during first power-up. After Vref has become stable during the power on and initialization sequence, it must be maintained for proper operation of the CKE receiver. For proper self-refresh operation VREF must be maintained to this input.
76, 193	S0#, S1#	Input	Chip Select: S# enables (registered LOW) and disables (registered HIGH) the command decoder. All commands are masked when S# is registered HIGH. S# provides for external rank selection on systems with multiple ranks. S# is considered part of the command code.
73, 74, 192	RAS#, CAS#, WE#	Input	Command Inputs: RAS#, CAS#, and WE# (along with S#) define the command being entered.
54 (2GB), 71, 190	BA0, BA1, BA2 (2GB)	Input	Bank Address Inputs: BA0–BA1/BA2 define to which device bank an ACTIVE, READ, WRITE, or PRECHARGE command is being applied. BA0–BA1/BA2 define which mode register including MR, EMR, EMR(2), and EMR(3) is loaded during the LOAD MODE command.
57, 58, 60, 61, 63, 70, 176, 177, 179, 180, 182, 183, 188, 196 (1GB, 2GB)	A0–A12 (512MB) A0–A13 (1GB, 2GB)	Input	Address Inputs: Provide the row address for ACTIVE commands, and the column address and auto precharge bit (A10) for Read/Write commands, to select one location out of the memory array in the respective bank. A10 sampled during a PRECHARGE command determines whether the PRECHARGE applies to one device bank (A10 LOW, device bank selected by BA0–BA1/BA2) or all device banks (A10 HIGH). The address inputs also provide the op-code during a LOAD MODE command.
125, 134, 146, 155, 202, 211, 223, 232	DM0–DM7	Input	Input Data Mask: DM is an input mask signal for write data. Input data is masked when DM is sampled HIGH along with that input data during a WRITE access. DM is sampled on both edges of DQS. Although DM pins are input-only, the DM loading is designed to match that of DQ and DQS pins.

**Table 6: Pin Descriptions**

Pin numbers may not correlate with symbols; refer to Pin Assignment tables on page 3 for more information

PIN NUMBERS	SYMBOL	TYPE	DESCRIPTION
3, 4, 9, 10, 12, 13, 21, 22, 24, 25, 30, 31, 33, 34, 39, 40, 80, 81, 86, 87, 89, 90, 95, 96, 98, 99, 107, 108, 110, 111, 116, 117, 122, 123, 128, 129, 131, 132, 140, 141, 143, 144, 149, 150, 152, 153, 158, 159, 199, 200, 205, 206, 208, 209, 214, 215, 217, 218, 226, 227, 229, 230, 235, 236	DQ0–DQ63	I/O	Data Input/Output: Bidirectional data bus.
6, 7, 15, 16, 27, 28, 36, 37, 83, 84, 92, 93, 104, 105, 113, 114,	DQS0–DQS7, DQS0#–DQS7#	I/O	Data Strobe: Output with read data, input with write data for source synchronous operation. Edge-aligned with read data, center aligned with write data. DQS# is only used when differential data strobe mode is enabled via the LOAD MODE command.
120	SCL	Input	Serial Clock for Presence-Detect: SCL is used to synchronize the presence-detect data transfer to and from the module.
101, 239, 240	SA0–SA2	Input	Presence-Detect Address Inputs: These pins are used to configure the presence-detect device.
119	SDA	Input/Output	Serial Presence-Detect Data: SDA is a bidirectional pin used to transfer addresses and data into and out of the presence-detect portion of the module.
53, 59, 64, 67, 69, 172, 178, 184, 187, 189, 197,	VDD	Supply	Power Supply: +1.8V ±0.1V.
51, 56, 62, 72, 75, 78, 170, 175, 181, 191, 194,	VDDQ	Supply	DQ Power Supply: +1.8V ±0.1V.
1	VREF	Supply	SSTL_18 reference voltage.
2, 5, 8, 11, 14, 17, 20, 23, 26, 29, 32, 35, 38, 41, 44, 47, 50, 65, 66, 79, 82, 85, 88, 91, 94, 97, 100, 103, 106, 109, 112, 115, 118, 121, 124, 127, 130, 133, 136, 139, 142, 145, 148, 151, 154, 157, 160, 163, 166, 169, 198, 201, 204, 207, 210, 213, 216, 219, 222, 225, 228, 231, 234, 237	Vss	Supply	Ground.
238	VDDSPD	Supply	Serial EEPROM positive power supply: +1.7V to +3.6V.
18, 19, 42, 43, 45, 46, 48, 49, 54 (512MB, 1GB), 55, 68, 76, 102, 125, 126, 134, 135, 146, 147, 155, 156, 161, 162, 164, 165, 167, 168, 171, 173, 174, 196 (512MB), 202, 203, 211, 212, 223, 224, 232, 233	NC	—	No Connect: These pins should be left unconnected.

Figure 3: Functional Block Diagram

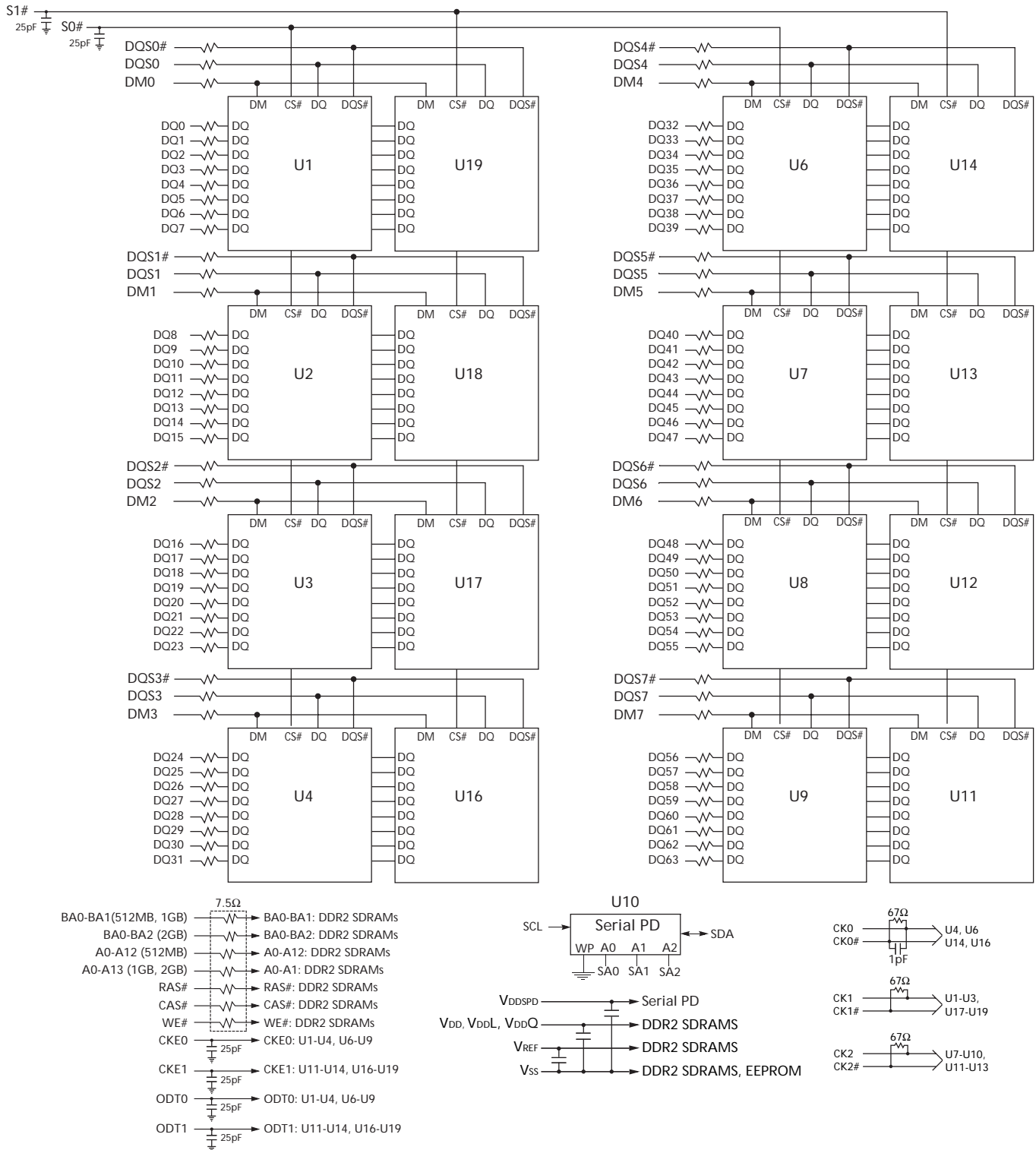

NOTE:

1. Unless otherwise noted, resistor values are 22Ω.
2. Micron module part numbers are explained in the Module Part Numbering Guide a [www.micron.com/support/numbering.html](http://www.micron.com/support/numbering.html).

Standard modules use the following DDR2 SDRAM devices:  
MT47H32M8FP (512MB); other components only available as lead-free.

Lead-free modules use the following DDR2 SDRAM devices:  
MT47H32M8BP (512MB); MT47H64M8BT (1GB); MT47H128M8BT (2GB).

## General Description

The MT16HTF6464A, MT16HTF12864A, and MT16HTF25664A DDR2 SDRAM modules are high-speed, CMOS, dynamic random-access 512MB, 1GB, and 2GB memory modules organized in x64 configuration. DDR2 SDRAM modules use internally configured quad-bank (512MB, 1GB) or eight-bank (2GB) DDR2 SDRAM devices.

DDR2 SDRAM modules use double data rate architecture to achieve high-speed operation. The double data rate architecture is essentially a  $4n$ -prefetch architecture with an interface designed to transfer two data words per clock cycle at the I/O pins. A single read or write access for the DDR2 SDRAM module effectively consists of a single  $4n$ -bit-wide, one-clock-cycle data transfer at the internal DRAM core and four corresponding  $n$ -bit-wide, one-half-clock-cycle data transfers at the I/O pins.

A bidirectional data strobe (DQS, DQS#) is transmitted externally, along with data, for use in data capture at the receiver. DQS is a strobe transmitted by the DDR2 SDRAM device during READs and by the memory controller during WRITEs. DQS is edge-aligned with data for READs and center-aligned with data for WRITEs.

DDR2 SDRAM modules operate from a differential clock (CK and CK#); the crossing of CK going HIGH and CK# going LOW will be referred to as the positive edge of CK. Commands (address and control signals) are registered at every positive edge of CK. Input data is registered on both edges of DQS, and output data is referenced to both edges of DQS, as well as to both edges of CK.

Read and write accesses to DDR2 SDRAM modules are burst-oriented; accesses start at a selected location and continue for a programmed number of locations in a programmed sequence. Accesses begin with the registration of an ACTIVE command, which is then followed by a READ or WRITE command. The address bits registered coincident with the ACTIVE command are used to select the device bank and row to be accessed. The address bits registered coincident with the READ or WRITE command are used to select the device bank and the starting column location for the burst access.

DDR2 SDRAM modules provide for programmable read or write burst lengths of four or eight locations. DDR2 SDRAM devices support interrupting a burst read of eight with another read, or a burst write of eight with another write. An auto precharge function may be enabled to provide a self-timed row precharge that is initiated at the end of the burst access.

The pipelined, multibank architecture of DDR2 SDRAM devices allows for concurrent operation, thereby providing high, effective bandwidth by hiding row precharge and activation time.

A self refresh mode is provided, along with a power-saving power-down mode.

All inputs are compatible with the JEDEC standard for SSTL<sub>18</sub>. All full drive-strength outputs are SSTL<sub>18</sub>-compatible.

## Serial Presence-Detect Operation

DDR2 SDRAM modules incorporate serial presence-detect (SPD). The SPD function is implemented using a 2,048-bit EEPROM. This nonvolatile storage device contains 256 bytes. The first 128 bytes can be programmed by Micron to identify the module type and various SDRAM organizations and timing parameters. The remaining 128 bytes of storage are available for use by the customer. System READ/WRITE operations between the master (system logic) and the slave EEPROM device occur via a standard I<sup>2</sup>C bus using the DIMM's SCL (clock) and SDA (data) signals, together with SA (2:0), which provide eight unique DIMM/EEPROM addresses. Write protect (WP) is tied to ground on the module, permanently disabling hardware write protect.

## Initialization

The following sequence is required for power-up and initialization and is shown in Figure 4, DDR2 Power-Up and Initialization, on page 9.

1. Apply power; if CKE is maintained below 20 percent of VDDQ, outputs remain disabled. To guarantee RTT (ODT Resistance) is off, VREF must be valid and a low level must be applied to the ODT pin (all other inputs may be undefined). The time from when VDD first starts to power-up to the completion of VDDQ must be equal to or less than 10ms. At least one of the following two sets of conditions (A or B) must be met:

A. CONDITION SET A

- VDD, VDDL and VDDQ are driven from a single power converter output
- VTT is limited to 0.95V MAX
- VREF tracks VDDQ/2

B. CONDITION SET B

- Apply VDD before or at the same time as VDDL.
- Apply VDDL before or at the same time as VDDQ
- Apply VDDQ before or at the same time as VTT and VREF

- The voltage difference between any VDD supply can not exceed 0.5V. For a minimum of 200 $\mu$ s after stable power and clock (CK, CK#), apply NOP or DESELECT commands and take CKE HIGH
2. Wait a minimum of 400ns, then issue a PRECHARGE ALL command.
  3. Issue a LOAD MODE command to the EMR(2) register. (To issue an EMR(2) command, provide LOW to BA0 and BA2, provide HIGH to BA1.)
  4. Issue a LOAD MODE command to the EMR(3) register. (To issue an EMR(3) command, provide HIGH to BA0 and BA1, provide LOW to BA2.)
  5. Issue a LOAD MODE command to the EMR register to enable DLL. To issue a DLL ENABLE command, provide LOW to BA1, BA2, and A0, provide HIGH to BA0. Bits E7, E8, and E9 must all be set to 0.
  6. Issue a LOAD MODE command for DLL Reset. 200 cycles of clock input is required to lock the DLL. (To issue a DLL Reset, provide HIGH to A8 and provide LOW to BA2, BA1 and BA0.) CKE must be HIGH the entire time.
  7. Issue PRECHARGE ALL command.
  8. Issue two or more REFRESH commands.
  9. Issue a LOAD MODE command with LOW to A8 to initialize device operation (i.e., to program operating parameters without resetting the DLL).
  10. Issue a LOAD MODE command to the EMR to enable OCD default by setting Bits E7, E8, and E9 to 1 and set all other desired parameters.
  11. Issue a LOAD MODE command to the EMR to enable OCD exit by setting Bits E7, E8, and E9 to 0 and set all other desired parameters.
  12. The DDR2 SDRAM device is now initialized and ready for normal operation 200 clocks after DLL Reset in step 6.



Figure 4: DDR2 Power-Up and Initialization

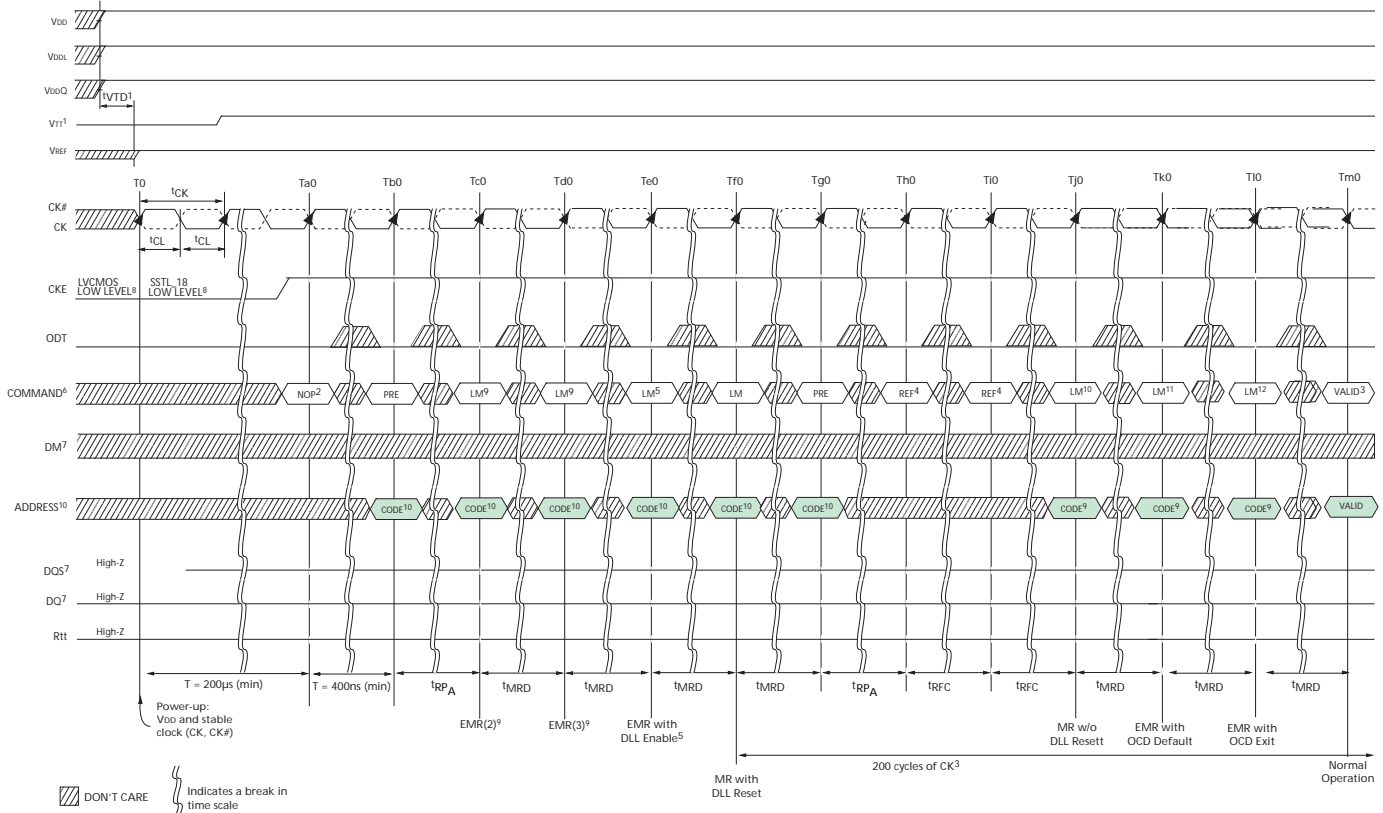

NOTE:

1. VTT is not applied directly to the device; however,  $t_{VTD}$  should be greater than or equal to zero to avoid device latch-up. The time from when VDD first starts to power-up to the completion of VDDQ must be equal to or less than 10ms. One of the following two conditions (a or b) MUST be met:
  - a) VDD, VDDL, and VDDQ are driven from a single power converter output.
    - VTT may be 0.95V maximum during power up.
    - VREF tracks VDDQ/2.
  - b) Apply VDD before or at the same time as VDDL.
    - Apply VDDL before or at the same time as VDDQ.
    - Apply VDDQ before or at the same time as VTT and VREF. The voltage difference between any VDD supply can not exceed 0.5V.
2. Either a NOP or DESELECT command may be applied.
3. 200 cycles of clock (CK, CK#) are required before a READ command can be issued. CKE must be HIGH the entire time.
4. Two or more REFRESH commands are required.
5. Bits E7, E8, and E9 must all be set to 0 with all other operating parameters of EMRS set as required.
6. PRE = PRECHARGE command, LM = LOAD MODE command, REF = REFRESH command, ACT = ACTIVE command, RA = Row Address, BA = Bank Address.
7. DM represents all DM. DQS represents all DQS, DQS#, RDQS, and RDQS# (RDQS/RDQS# only functional on RDIMMs using x8 components). DQ represents all DQ.
8. CKE pin uses LVCMOS input levels prior to state T0. After state T0, CKE pin uses SSTL\_18 input levels.
9. A10 should be HIGH at states Tb0 and Tg0 to ensure a PRECHARGE (all banks) command is issued.
10. Bits E7, E8, and E9 must be set to 1 to set OCD default.
11. Bits E7, E8, and E9 must be set to 0 to set OCD exit and all other operating parameters of EMRS set as required.

## Mode Register (MR)

The mode register is used to define the specific mode of operation of the DDR2 SDRAM device. This definition includes the selection of a burst length, burst type, CAS latency, operating mode, DLL reset, write recovery, and power-down mode as shown in Figure 5, Mode Register (MR) Definition. Contents of the mode register can be altered by re-executing the LOAD MODE (LM) command. If the user chooses to modify only a subset of the MR variables, all variables (M0–M14) must be programmed when the LOAD MODE command is issued.

The mode register is programmed via the LM command (bits BA0–BA1/BA2 all = 0) and other bits (M0–M13 or M0–M14) will retain the stored information until it is programmed again or the device loses power (except for bit M8, which is self-clearing). Reprogramming the mode register will not alter the contents of the memory array, provided it is performed correctly.

The LOAD MODE command can only be issued (or reissued) when all banks are in the precharged state. The controller must wait the specified time <sup>t</sup>MRD before initiating any subsequent operations such as an ACTIVE command. Violating either of these requirements will result in unspecified operation.

## Burst Length

Burst length is defined by bits M0–M2 as shown in Figure 5, Mode Register (MR) Definition. Read and write accesses to the DDR2 SDRAM device are burst-oriented, with the burst length being programmable to either four or eight. The burst length determines the maximum number of column locations that can be accessed for a given READ or WRITE command.

When a READ or WRITE command is issued, a block of columns equal to the burst length is effectively selected. All accesses for that burst take place within this block, meaning that the burst will wrap within the block if a boundary is reached. The block is uniquely selected by A2–A<sub>i</sub> when the burst length is set to four and by A3–A<sub>i</sub> when the burst length is set to eight (where A<sub>i</sub> is the most significant column address bit for a given configuration). The remaining (least significant) address bit(s) is (are) used to select the starting location within the block. The programmed burst length applies to both READ and WRITE bursts.

## Burst Type

Accesses within a given burst may be programmed to be either sequential or interleaved. The burst type is selected via bit M3 as shown in Figure 5, Mode Register (MR) Definition. The ordering of accesses within a

burst is determined by the burst length, the burst type, and the starting column address as shown in Table 7, Burst Definition, on page 11. DDR2 SDRAM device support 4-bit burst and 8-bit burst modes only. For 8-bit burst mode, full interleave address ordering is supported; however, sequential address ordering is nibble-based.

**Figure 5: Mode Register (MR) Definition**

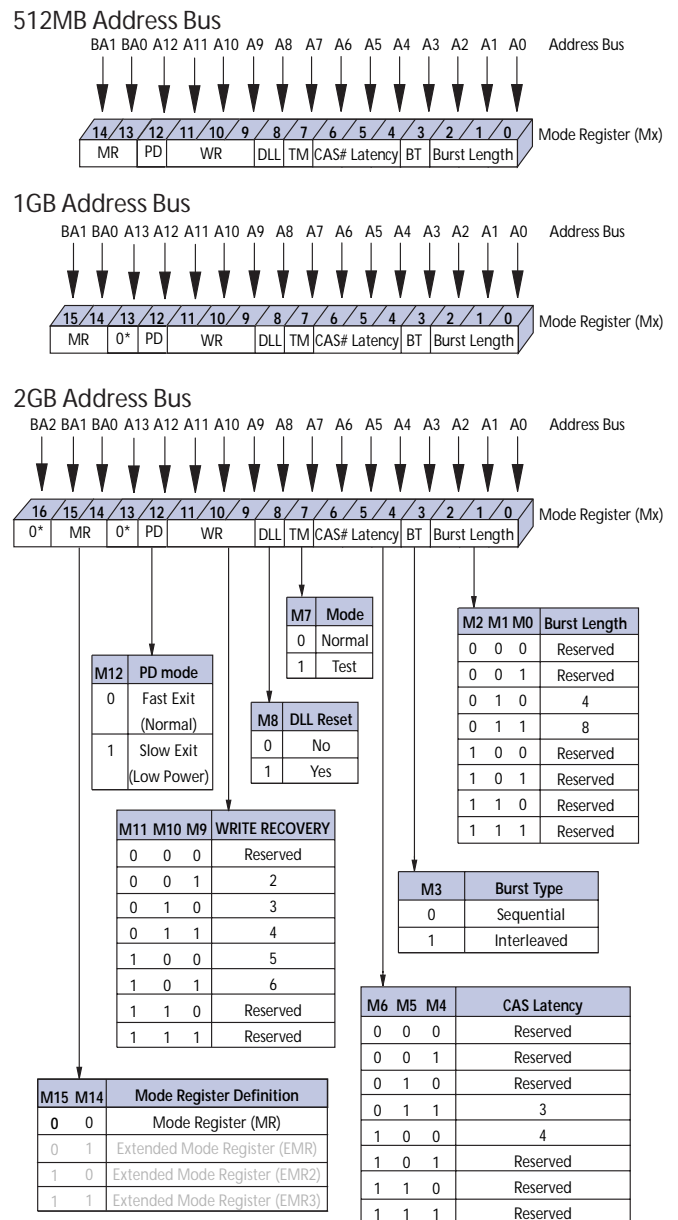

\*M13 (A13) and M16 (BA2) are reserved for future use and must be programmed to '0'. A13 is not used in x16 configuration.

**Table 7: Burst Definition**

BURST LENGTH	STARTING COLUMN ADDRESS (A2, A1, A0)	ORDER OF ACCESSES WITHIN A BURST	
		BURST TYPE = SEQUENTIAL	BURST TYPE = INTERLEAVED
4	0 0 0	0,1,2,3	0,1,2,3
	0 0 1	1,2,3,0	1,0,3,2
	0 1 0	2,3,0,1	2,3,0,1
	0 1 1	3,0,1,2	3,2,1,0
8	0 0 0	0,1,2,3,4,5,6,7	0,1,2,3,4,5,6,7
	0 0 1	1,2,3,0,5,6,7,4	1,0,3,2,5,4,7,6
	0 1 0	2,3,0,1,6,7,4,5	2,3,0,1,6,7,4,5
	0 1 1	3,0,1,2,7,4,5,6	3,2,1,0,7,6,5,4
	1 0 0	4,5,6,7,0,1,2,3	4,5,6,7,0,1,2,3
	1 0 1	5,6,7,4,1,2,3,0	5,4,7,6,1,0,3,2
	1 1 0	6,7,4,5,2,3,0,1	6,7,4,5,2,3,0,1
1 1 1	7,4,5,6,3,0,1,2	7,6,5,4,3,2,1,0	

### Operating Mode

The normal operating mode is selected by issuing a LOAD MODE command with bit M7 set to zero, and all other bits set to the desired values as shown in Figure 5, Mode Register (MR) Definition, on page 10. When bit M7 is '1,' no other bits of the mode register are programmed. Programming bit M7 to '1' places the DDR2 SDRAM device into a test mode that is only used by the Manufacturer and should NOT be used. No operation or functionality is guaranteed if M7 bit is '1.'

### DLL Reset

DLL reset is defined by bit M8 as shown in Figure 5, Mode Register (MR) Definition, on page 10. Programming bit M8 to '1' will activate the DLL RESET function. Bit M8 is self-clearing, meaning it returns back to a value of '0' after the DLL RESET function has been issued.

Anytime the DLL RESET function is used, 200 clock cycles must occur before a READ command can be issued to allow time for the internal clock to be synchronized with the external clock. Failing to wait for synchronization to occur may result in a violation of the <sup>t</sup>AC or <sup>t</sup>DQSCK parameters.

### Write Recovery

Write recovery (WR) time is defined by bits M9–M11 as shown in Figure 5, Mode Register (MR) Definition, on page 10. The WR Register is used by the DDR2 SDRAM device during WRITE with AUTO PRECHARGE operation. During WRITE with AUTO PRECHARGE

operation, the DDR2 SDRAM device delays the internal AUTO PRECHARGE operation by WR clocks (programmed in bits M9–M11) from the last data burst.

Write Recovery (WR) values of 2, 3, 4, 5, or 6 clocks may be used for programming bits M9–M11. The user is required to program the value of write recovery, which is calculated by dividing <sup>t</sup>WR (in ns) by <sup>t</sup>CK (in ns) and rounding up a noninteger value to the next integer; WR [cycles] = <sup>t</sup>WR [ns] / <sup>t</sup>CK [ns]. Reserved states should not be used as unknown operation or incompatibility with future versions may result.

### Power-Down Mode

Active power-down (PD) mode is defined by bit M12 as shown in Figure 5, Mode Register (MR) Definition, on page 10. PD mode allows the user to determine the active power-down mode, which determines performance vs. power savings. PD mode bit M12 does not apply to precharge power-down mode.

When bit M12 = 0, standard Active Power-down mode or 'fast-exit' active power-down mode is enabled. The <sup>t</sup>XARD parameter is used for 'fast-exit' active power-down exit timing. The DLL is expected to be enabled and running during this mode.

When bit M12 = 1, a lower power active power-down mode or 'slow-exit' active power-down mode is enabled. The <sup>t</sup>XARDS parameter is used for 'slow-exit' active power-down exit timing. The DLL can be enabled, but 'frozen' during active power-down mode since the exit-to-READ command timing is relaxed. The power difference expected between PD 'normal' and PD 'low-power' mode is defined in the IDD table.

### CAS Latency (CL)

The CAS Latency (CL) is defined by bits M4–M6 as shown in Figure 5, Mode Register (MR) Definition, on page 10. CAS Latency is the delay, in clock cycles, between the registration of a READ command and the availability of the first bit of output data. The CAS Latency can be set to 3 or 4 clocks. CAS Latency of 2 or 5 clocks are JEDEC optional features and may be enabled in future speed grades. DDR2 SDRAM devices do not support any half clock latencies. Reserved states should not be used as unknown operation or incompatibility with future versions may result.

DDR2 SDRAM devices also support a feature called Posted CAS additive latency (AL). This feature allows the READ command to be issued prior to <sup>t</sup>RCD(MIN) by delaying the internal command to the DDR2 SDRAM device by AL clocks. The AL feature is described in more detail in the Extended Mode Register (EMR) and Operational sections.

Examples of CL = 3 and CL = 4 are shown in Figure 6, CAS Latency (CL); both assume AL = 0. If a READ command is registered at clock edge  $n$ , and the CAS

Latency is  $m$  clocks, the data will be available nominally coincident with clock edge  $n + m$  (this assumes AL = 0).

**Figure 6: CAS Latency (CL)**

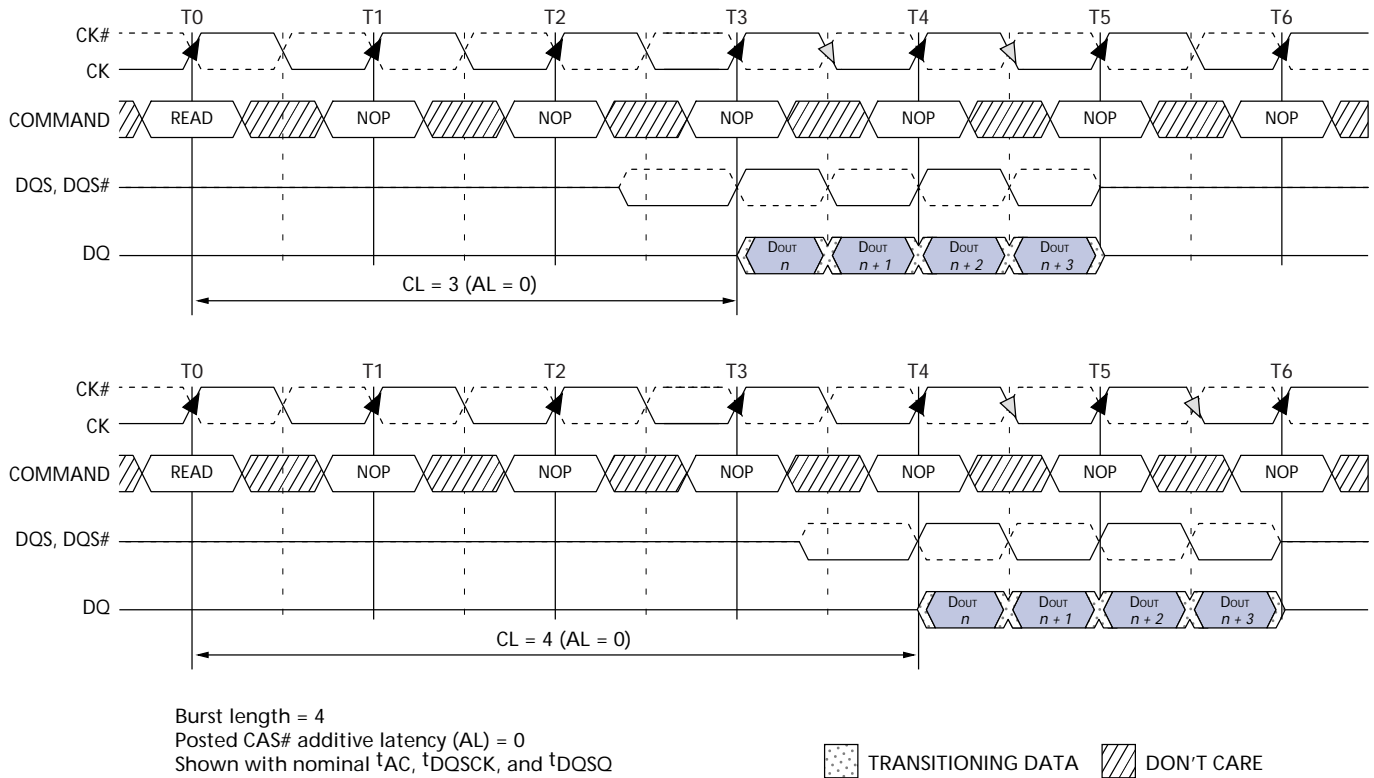

## Extended Mode Register (EMR)

The extended mode register controls functions beyond those controlled by the mode register; these additional functions are DLL enable/disable, output drive strength, ODT (Rtt), Posted CAS additive latency (AL), off-chip driver impedance calibration (OCD), DQS# enable/disable, RDQS/RDQS# enable/disable, and OUTPUT disable/enable. These functions are controlled via the bits shown in Figure 7, Extended Mode Register Definition. The extended mode register is programmed via the LOAD MODE (LM) command and will retain the stored information until it is programmed again or the device loses power. Reprogramming the extended mode register will not alter the contents of the memory array, provided it is performed correctly.

The extended mode register must be loaded when all banks are idle and no bursts are in progress, and the controller must wait the specified time  $t_{MRD}$  before initiating any subsequent operation. Violating either of these requirements could result in unspecified operation.

### DLL Enable/Disable

The DLL may be enabled or disabled by programming bit E0 during the LOAD MODE command as shown in Figure 7, Extended Mode Register Definition. The DLL must be enabled for normal operation. DLL enable is required during power-up initialization and upon returning to normal operation after having disabled the DLL for the purpose of debugging or evaluation. Enabling the DLL should always be followed by resetting the DLL using a LOAD MODE command.

The DLL is automatically disabled when entering self refresh operation and is automatically re-enabled and reset upon exit of self refresh operation.

Any time the DLL is enabled (and subsequently reset), 200 clock cycles must occur before a READ command can be issued to allow time for the internal clock to be synchronized with the external clock. Failing to wait for synchronization to occur may result in a violation of the  $t_{AC}$  or  $t_{DQSCK}$  parameters.

### Output Drive Strength

The output drive strength is defined by bit E1 as shown in Figure 7, Extended Mode Register Definition. The normal drive strength for all outputs are specified to be SSTL<sub>18</sub>. Programming bit E1 = 0 selects normal (100 percent) drive strength for all outputs. Selecting a

reduced drive strength option (bit E1 = 1) will reduce all outputs to approximately 60 percent of the SSTL<sub>18</sub> drive strength. This option is intended for the support of the lighter load and/or point-to-point environments.

**Figure 7: Extended Mode Register Definition**

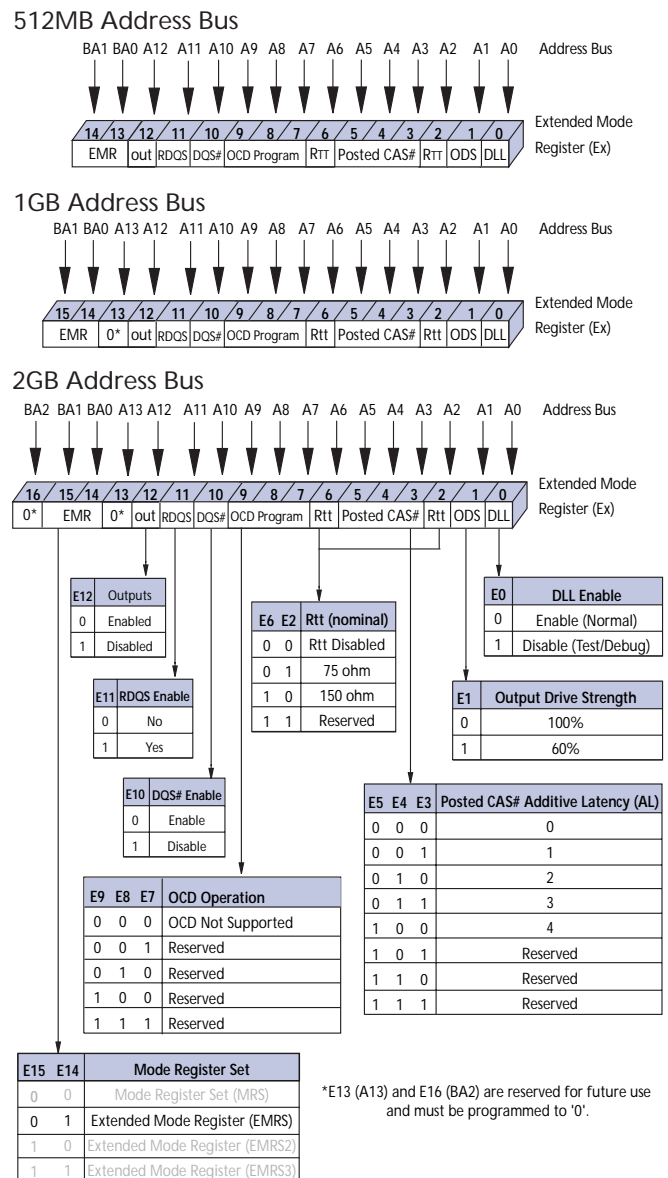

### DQS# Enable/Disable

The DQS# enable function is defined by bit E10. When enabled (bit E10 = 0), DQS# is the complement of the differential data strobe pair DQS/DQS#. When disabled (bit E10 = 1), DQS is used in a single-ended mode and the DQS# pin is disabled. This function is also used to enable/disable RDQS#. If RDQS is enabled (E11 = 1) and DQS# is enabled (E10 = 0), then both DQS# and RDQS# will be enabled. RDQS/RDQS# is supported only on RDIMMs using x8 DDR2 SDRAM devices.

### RDQS Enable/Disable

RDQS/RDQS# is supported only on RDIMMs using x8 DDR2 SDRAM devices. The RDQS enable function is defined by bit E11 as shown in Figure 7, Extended Mode Register Definition, on page 13. When enabled (E11 = 1), RDQS is identical in function and timing to data strobe DQS during a READ. During a WRITE operation, RDQS is ignored by the DDR2 SDRAM device.

### Output Enable/Disable

The OUTPUT enable function is defined by bit E12 as shown in Figure 7, Extended Mode Register Definition, on page 13. When enabled (E12 = 0), all outputs (DQs, DQS, DQS#, RDQS, RDQS#) function normally. When disabled (E12 = 1), all DDR2 SDRAM device outputs (DQs, DQS, DQS#, RDQS, RDQS#) are disabled removing output buffer current. The OUTPUT disable feature is intended to be used during IDD characterization of read current.

### On Die Termination (ODT)

ODT effective resistance  $R_{TT(EFF)}$  is defined by bits E2 and E6 of the EMR as shown in Figure 7, Extended Mode Register Definition, on page 13. The ODT feature is designed to improve signal integrity of the memory channel by allowing the DDR2 SDRAM device controller to independently turn on/off ODT for any or all devices.  $R_{TT}$  effective resistance values of 75Ω and 150Ω are selectable and apply to each DQ, DQS/DQS#, RDQS/RDQS#, and DM signals. Bits (E6, E2) determine what ODT resistance is enabled by turning on/off 'sw1' or 'sw2.' The ODT effective resistance value is selected by enabling switch 'sw1,' which enables all 'R1' values that are 150Ω each, enabling an effective resistance of 75Ω ( $R_{TT1(EFF)} = 'R1' / 2$ ). Similarly, if 'sw2' is enabled, all 'R2' values that are 300Ω each, enable an effective ODT resistance of 150Ω ( $R_{TT2(EFF)} = 'R2' / 2$ ). Reserved states should not be used, as unknown operation or incompatibility with future versions may result.

The ODT control pin is used to determine when  $R_{TT(EFF)}$  is turned on and off, assuming ODT has been enabled via bits E2 and E6 of the EMR. The ODT feature and ODT input pin are only used during active, active power-down (both fast-exit and slow-exit modes), and precharge power-down modes of operation. If SELF REFRESH operation is used,  $R_{TT(EFF)}$  should *always* be disabled and the ODT input pin is disabled by the DDR2 SDRAM device. During power-up and initialization of the DDR2 SDRAM device, ODT should be disabled until the EMR command is issued to enable the ODT feature, at which point the ODT pin will determine the  $R_{TT(EFF)}$  value. Refer to the 256Mb, 512Mb, or 1Gb DDR2 SDRAM discrete data sheet for ODT timing diagrams.

### Off-Chip Driver (OCD) Impedance Calibration

The OCD function is not supported and must be set to the default state. e “Initialization” on page 7, to properly set OCD defaults.

### Posted CAS Additive Latency (AL)

Posted CAS additive latency (AL) is supported to make the command and data bus efficient for sustainable bandwidths in DDR2 SDRAM device. Bits E3–E5 define the value of AL as shown in Figure 7, Extended Mode Register Definition, on page 13. Bits E3–E5 allow the user to program the DDR2 SDRAM device with a CAS# additive latency of 0, 1, 2, 3, or 4 clocks. Reserved states should not be used as unknown operation or incompatibility with future versions may result.

In this operation, the DDR2 SDRAM device allows a READ or WRITE command to be issued prior to  $t_{RCD}(\text{MIN})$  with the requirement that  $AL \leq t_{RCD}(\text{MIN})$ . A typical application using this feature would set  $AL = t_{RCD}(\text{MIN}) - 1 \times t_{CK}$ . The READ or WRITE command is held for the time of the additive latency (AL) before it is issued internally to the DDR2 SDRAM device. READ Latency (RL) is controlled by the sum of the Posted CAS additive latency (AL) and CAS Latency (CL);  $RL = AL + CL$ . Write latency (WL) is equal to READ latency minus one clock;  $WL = AL + CL - 1 \times t_{CK}$ . An example of a READ latency is shown in Figure 8, READ Latency. An example of a WRITE latency is shown in Figure 9, Write Latency.

Figure 8: READ Latency

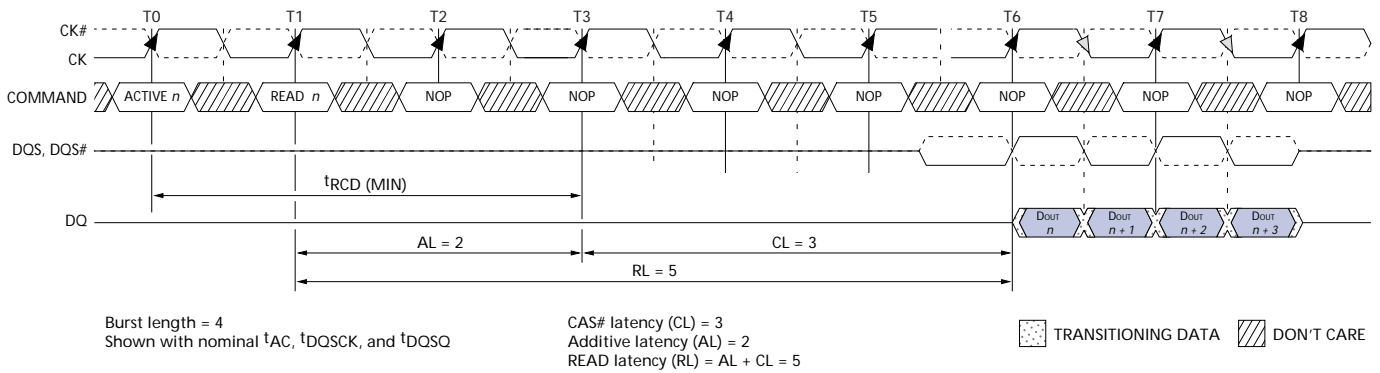
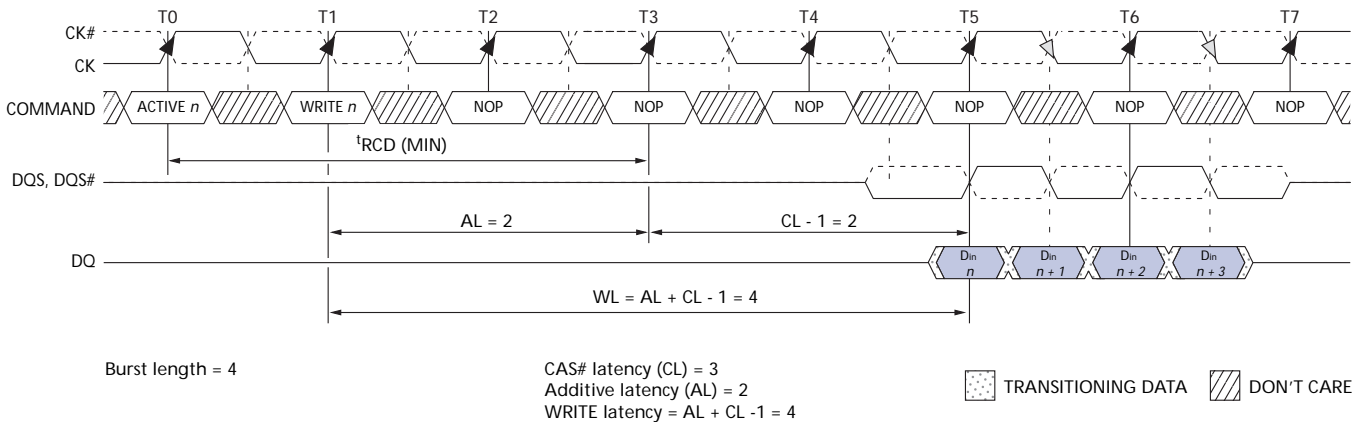

Figure 9: Write Latency



### Extended Mode Register 2 (EMR2)

The Extended Mode Register 2 (EMR2) controls functions beyond those controlled by the mode register. Currently all bits in EMR2 are reserved as shown in Figure 10, Extended Mode Register 2 (EMR2) Definition. The EMR2 is programmed via the LOAD MODE command and will retain the stored information until it is programmed again or the device loses power. Reprogramming the extended mode register will not alter the contents of the memory array, provided it is performed correctly.

The extended mode register must be loaded when all banks are idle and no bursts are in progress, and the controller must wait the specified time <sup>t</sup>MRD before initiating any subsequent operation. Violating either of these requirements could result in unspecified operation.

**Figure 10: Extended Mode Register 2 (EMR2) Definition**

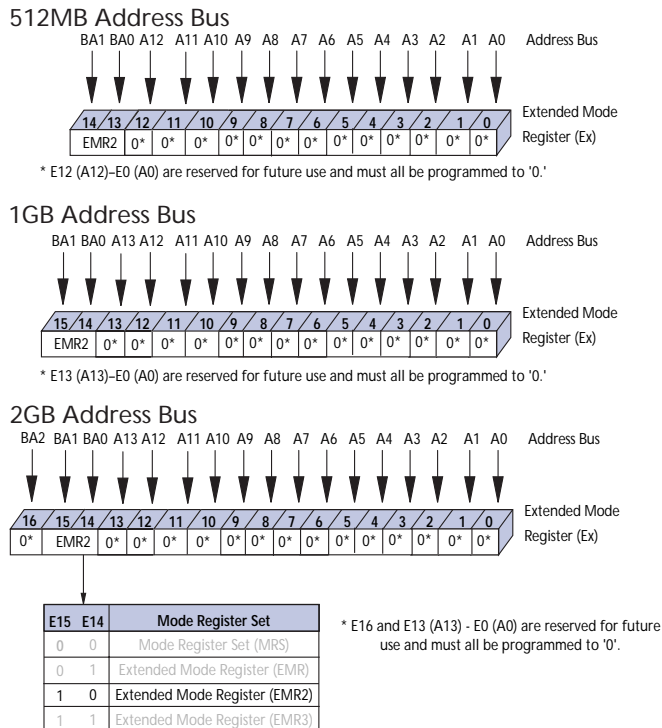

### Extended Mode Register 3 (EMR3)

The Extended Mode Register 3 (EMR3) controls functions beyond those controlled by the mode register. Currently all bits in EMR3 are reserved as shown in Figure 11, Extended Mode Register 3 (EMR3) Definition. The EMR3 is programmed via the LOAD MODE command and will retain the stored information until it is programmed again or the device loses power. Reprogramming the extended mode register will not alter the contents of the memory array, provided it is performed correctly.

The extended mode register must be loaded when all banks are idle and no bursts are in progress, and the controller must wait the specified time <sup>t</sup>MRD before initiating any subsequent operation. Violating either of these requirements could result in unspecified operation.

**Figure 11: Extended Mode Register 3 (EMR3) Definition**

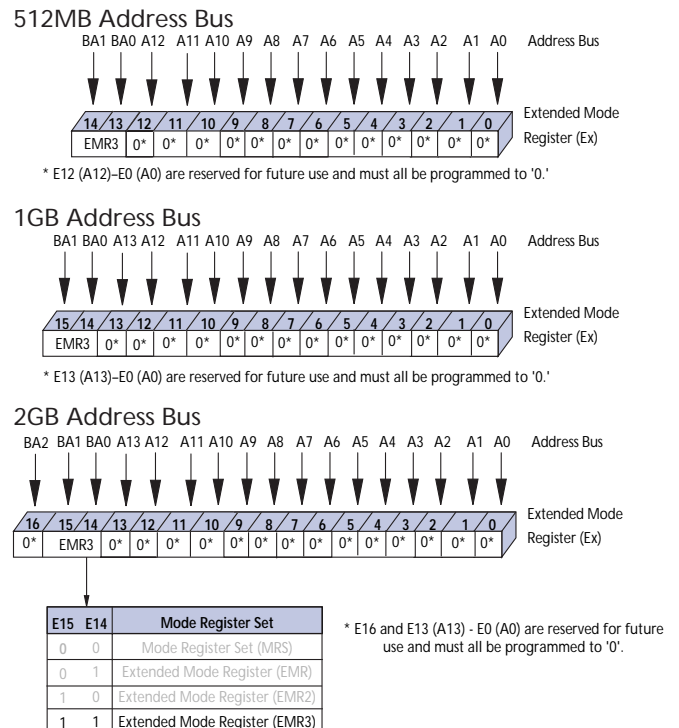



### Command Truth Tables

Table 8, Commands Truth Table provides a quick reference of DDR2 SDRAM device available commands. Refer to the 256Mb, 512Mb, or 1Gb DDR2

SDRAM component data sheet for more Truth Table definitions, including CKE power-down modes and device bank-to-bank commands.

**Table 8: Commands Truth Table**

Notes: 1, 5, 6

FUNCTION	CKE		S#	RAS#	CAS#	WE#	BA2 <sup>8</sup> , BA1, BA0	A13 <sup>8</sup> - A11	A10	A9-A0	NOTES
	PREVIOUS CYCLE	CURRENT CYCLE									
Mode Register Set	H	H	L	L	L	L	BA	OP Code			2
Refresh	H	H	L	L	L	H	X	X	X	X	
Self Refresh Entry	H	L	L	L	L	H	X	X	X	X	
Self Refresh Exit	L	H	X	X	X	X	X	X	X	X	7
			L	H	H	H	X	X	X	X	
Single Device Bank Precharge	H	H	L	L	H	L	BA	X	L	X	2
ALL Device Banks Precharge	H	H	L	L	H	L	X	X	H	X	
Device Bank Activate	H	H	L	L	H	H	BA	Row Address			2
Write	H	H	L	H	L	L	BA	Column Address	L	Column Address	2, 3
Write with Auto Precharge	H	H	L	H	L	L	BA	Column Address	H	Column Address	2, 3
Read	H	H	L	H	L	H	BA	Column Address	L	Column Address	2, 3
Read with Auto Precharge	H	H	L	H	L	H	BA	Column Address	H	Column Address	2, 3
No Operation	H	X	L	H	H	H	X	X	X	X	
Device Deselect	H	X	H	X	X	X	X	X	X	X	
Power-Down Entry	H	L	H	X	X	X	X	X	X	X	
			L	H	H	H	X	X	X	X	
Power-Down Exit	L	H	H	X	X	X	X	X	X	X	
			L	H	H	H	X	X	X	X	

NOTE:

- All DDR2 SDRAM device commands are defined by states of S#, RAS#, CAS#, WE#, and CKE at the rising edge of the clock.
- Device Bank addresses (BA) BA0-BA1/BA2 determine which device bank is to be operated upon. For EMR, BA selects an extended mode register.
- Burst reads or writes at BL = 4 cannot be terminated or interrupted. Refer to the 256Mb, 512Mb, or 1Gb DDR2 SDRAM discrete data sheet for other restrictions or details.
- The Power Down Mode does not perform any refresh operations. The duration of power-down is therefore limited by the refresh requirements outlined in the AC parametric section.
- The state of ODT does not affect the states described in this table. The ODT function is not available during self refresh. Refer to the 256Mb, 512Mb, or 1Gb DDR2 SDRAM discrete data sheet for other restrictions or details.
- "X" means "H or L" (but a defined logic level).
- Self refresh exit is asynchronous.
- BA2 valid for 2GB only; A13 valid for 1GB and 2GB only.

### Absolute Maximum Ratings

Stresses greater than those listed may cause permanent damage to the device. This is a stress rating only, and functional operation of the device at these or any other conditions above those indicated in the opera-

tional sections of this specification is not implied. Exposure to absolute maximum rating conditions for extended periods may affect reliability.

**Table 9: Absolute Maximum DC Ratings**

SYMBOL	PARAMETER	MIN	MAX	UNITS	
VDD	VDD Supply Voltage Relative to Vss	-1.0	2.3	V	
VDDQ	VDDQ Supply Voltage Relative to Vss	-0.5	2.3	V	
VDDL	VDDL Supply Voltage Relative to Vss	-0.5	2.3	V	
VIN, VOUT	Voltage on any Pin Relative to Vss	-0.5	2.3	V	
T <sub>STG</sub>	Storage Temperature	-55	100	°C	
T <sub>case</sub>	DDR2 SDRAM Device Operating Temperature (Ambient)	0	85	°C	
T <sub>OPR</sub>	Operating Temperature (Ambient)	0	55	°C	
I <sub>I</sub>	Input Leakage Current; Any input 0V ≤ VIN ≤ VDD; VREF input 0V ≤ VIN ≤ 0.95V; (All other pins not under test = 0V)	Command/Address, RAS#, CAS#, WE#	-80	80	μA
		S#, CKE	-40	40	
		CK0, CK0#	-20	20	
		CK1, CK1#, CK2, CK2#	-30	30	
		DM	-10	10	
I <sub>OZ</sub>	Output Leakage Current; 0V ≤ VOUT ≤ VDDQ; DQs and ODT are disabled	-10	10	μA	
I <sub>VREF</sub>	VREF Leakage Current; VREF = Valid VREF level	-32	32	μA	

**Table 10: Recommended DC Operating Conditions**

All voltages referenced to Vss

PARAMETER	SYMBOL	MIN	NOM	MAX	UNITS	NOTES
Supply Voltage	VDD	1.7	1.8	1.9	V	1
VDDL Supply Voltage	VDDL	1.7	1.8	1.9	V	4
I/O Supply Voltage	VDDQ	1.7	1.8	1.9	V	4
I/O Reference Voltage	VREF	0.49 x VDDQ	0.50 x VDDQ	0.51 x VDDQ	V	2
I/O Termination Voltage (system)	VTT	VREF - 40	VREF	VREF + 40	mV	3

NOTE:

- VDD and VDDQ must track each other. VDDQ must be less than or equal to VDD.
- VREF is expected to equal VDDQ/2 of the transmitting device and to track variations in the DC level of the same. Peak-to-peak noise (non-common mode) on VREF may not exceed ±1percent of the DC value. Peak-to-peak AC noise on VREF may not exceed ±2 percent of VREF (DC). This measurement is to be taken at the nearest VREF bypass capacitor.
- VTT is not applied directly to the device. VTT is a system supply for signal termination resistors, is expected to be set equal to VREF and must track variations in the DC level of VREF.
- VDDQ tracks with VDD; VDDL tracks with VDD.

## Input Electrical Characteristics and Operating Conditions

**Table 11: Input DC Logic Levels**

All voltages referenced to Vss

PARAMETER	SYMBOL	MIN	MAX	UNITS	NOTES
Input High (Logic 1) Voltage	V <sub>IH(DC)</sub>	V <sub>REF</sub> + 125	V <sub>DDQ</sub> + 300	mV	
Input Low (Logic 0) Voltage	V <sub>IL(DC)</sub>	-300	V <sub>REF</sub> - 125	mV	

**Table 12: Input AC Logic Levels**

All voltages referenced to Vss

PARAMETER	SYMBOL	MIN	MAX	UNITS	NOTES
Input High (Logic 1) Voltage	V <sub>IH(AC)</sub>	V <sub>REF</sub> + 250	-	mV	
Input Low (Logic 0) Voltage	V <sub>IL(AC)</sub>	-	V <sub>REF</sub> - 250	mV	

### IDD Specifications and Conditions

IDD specifications are tested after the device is properly initialized.  $0^{\circ}\text{C} \leq T_{\text{CASE}} \leq +85^{\circ}\text{C}$ .  $V_{\text{DD}} = V_{\text{DDQ}} = V_{\text{DDL}} = +1.8\text{V} \pm 0.1\text{V}$ ;  $V_{\text{REF}} = V_{\text{DDQ}}/2$ .

Input slew rate is specified by AC Parametric Test Conditions. IDD parameters are specified with ODT disabled. Data bus consists of DQ, DM, DQS, DQS#. IDD values must be met with all combinations of EMR bits 10 and 11.

Definitions for IDD Conditions:

- LOW is defined as  $V_{\text{IN}} \leq V_{\text{IL}}(\text{AC})$  (MAX)
- HIGH is defined as  $V_{\text{IN}} \geq V_{\text{IH}}(\text{AC})$  (MIN)

- STABLE is defined as inputs stable at a HIGH or LOW level
- FLOATING is defined as inputs at  $V_{\text{REF}} = V_{\text{DDQ}}/2$
- SWITCHING is defined as inputs changing between HIGH and LOW every other clock cycle (once per two clocks) for address and control signals
- Switching is defined as inputs changing between HIGH and LOW every other data transfer (once per clock) for DQ signals not including masks or strobes

**Table 13: General IDD Parameters**

IDD PARAMETER		-53E	-40E	UNITS
CL (IDD)		4	3	t <sub>CK</sub>
t <sub>RCD</sub> (IDD)		15	15	ns
t <sub>RC</sub> (IDD)		60	55	ns
t <sub>RRD</sub> (IDD)		7.5	7.5	ns
t <sub>CK</sub> (IDD)		3.75	5	ns
t <sub>RAS MIN</sub> (IDD)		45	40	ns
t <sub>RAS MAX</sub> (IDD)		70,000	70,000	ns
t <sub>RP</sub> (IDD)		15	15	ns
t <sub>RFC</sub> (IDD)	512MB	75	75	ns
	1GB	105	105	ns
	2GB	127.5	127.5	ns



**IDD7 Conditions**

Table 14, IDD7 Timing Patterns, specifies detailed timing requirements for IDD7. Changes will be required if timing parameter changes are made to the specification.

**Table 14: IDD7 Timing Patterns**

All Bank Interleave Read operation; Legend: A = active; RA = read auto precharge; D = deselect

DEVICE BANKS	SPEED GRADE	IDD7 TIMING PATTERNS
4	-40E	A0 RA0 A1 RA1 A2 RA2 A3 RA3 D D D D
	-53E	A0 RA0 D A1 RA1 D A2 RA2 D A3 RA3 D D D D D
8	-40E	A0 RA0 A1 RA1 A2 RA2 A3 RA3 A4 RA4 A5 RA5 A6 RA6 A7 RA7
	-53E	A0 RA0 A1 RA1 A2 RA2 A3 RA3 D D A4 RA4 A5 RA5 A6 RA6 A7 RA7 D D

NOTE:

All banks are being interleaved at minimum  $t_{RC} (IDD)$  without violating  $t_{RRD} (IDD)$  using a burst length of 4; control and address bus inputs are STABLE during DESELECTs;  $I_{OUT} = 0mA$ .

**Table 15: DDR2 IDD Specifications and Conditions – 512MB**

Notes: 1–5; notes appear on page 28. Values shown for DDR2 SDRAM components only.

PARAMETER/CONDITION	SYMBOL	-53E	-40E	UNITS	
<b>Operating one device bank active-precharge current;</b> $t_{CK} = t_{CK} (I_{DD})$ , $t_{RC} = t_{RC} (I_{DD})$ , $t_{RAS} = t_{RAS} \text{ MIN} (I_{DD})$ ; CKE is HIGH, S# is HIGH between valid commands; Address bus inputs are SWITCHING; Data bus inputs are SWITCHING.	$I_{DD0}^a$	680	640	mA	
<b>Operating one device bank active-read-precharge current;</b> $I_{OUT} = 0\text{mA}$ ; BL = 4, CL = CL(I <sub>DD</sub> ), AL = 0; $t_{CK} = t_{CK} (I_{DD})$ , $t_{RC} = t_{RC} (I_{DD})$ , $t_{RAS} = t_{RAS} \text{ MIN} (I_{DD})$ , $t_{RCD} = t_{RCD} (I_{DD})$ ; CKE is HIGH, S# is HIGH between valid commands; Address bus inputs are SWITCHING; Data pattern is same as I <sub>DD4W</sub> .	$I_{DD1}^a$	760	720	mA	
<b>Precharge power-down current;</b> All device banks idle; $t_{CK} = t_{CK} (I_{DD})$ ; CKE is LOW; Other control and address bus inputs are STABLE; Data bus inputs are FLOATING.	$I_{DD2P}^b$	80	80	mA	
<b>Precharge quiet standby current;</b> All device banks idle; $t_{CK} = t_{CK} (I_{DD})$ ; CKE is HIGH, S# is HIGH; Other control and address bus inputs are STABLE; Data bus inputs are FLOATING.	$I_{DD2Q}^b$	560	400	mA	
<b>Precharge standby current;</b> All device banks idle; $t_{CK} = t_{CK} (I_{DD})$ ; CKE is HIGH, S# is HIGH; Other control and address bus inputs are SWITCHING; Data bus inputs are SWITCHING.	$I_{DD2N}^b$	560	480	mA	
<b>Active power-down current;</b> All device banks open; $t_{CK} = t_{CK} (I_{DD})$ ; CKE is LOW; Other control and address bus inputs are STABLE; Data bus inputs are FLOATING.	$I_{DD3P}^b$	Fast PDN Exit MR[12] = 0	400	320	mA
		Slow PDN Exit MR[12] = 1	96	96	mA
<b>Active standby current;</b> All device banks open; $t_{CK} = t_{CK}(I_{DD})$ , $t_{RAS} = t_{RAS} \text{ MAX} (I_{DD})$ , $t_{RP} = t_{RP}(I_{DD})$ ; CKE is HIGH, S# is HIGH between valid commands; Other control and address bus inputs are SWITCHING; Data bus inputs are SWITCHING.	$I_{DD3N}^b$	640	480	mA	
<b>Operating burst write current;</b> All device banks open, Continuous burst writes; BL = 4, CL = CL (I <sub>DD</sub> ), AL = 0; $t_{CK} = t_{CK} (I_{DD})$ , $t_{RAS} = t_{RAS} \text{ MAX} (I_{DD})$ , $t_{RP} = t_{RP} (I_{DD})$ ; CKE is HIGH, S# is HIGH between valid commands; Address bus inputs are SWITCHING; Data bus inputs are SWITCHING.	$I_{DD4W}^a$	1,320	1,040	mA	
<b>Operating burst read current;</b> All device banks open, Continuous burst reads, $I_{OUT} = 0\text{mA}$ ; BL = 4, CL = CL (I <sub>DD</sub> ), AL = 0; $t_{CK} = t_{CK} (I_{DD})$ , $t_{RAS} = t_{RAS} \text{ MAX} (I_{DD})$ , $t_{RP} = t_{RP} (I_{DD})$ ; CKE is HIGH, S# is HIGH between valid commands; Address bus inputs are SWITCHING; Data bus inputs are SWITCHING.	$I_{DD4R}^a$	1,240	960	mA	
<b>Burst refresh current;</b> $t_{CK} = t_{CK} (I_{DD})$ ; Refresh command at every $t_{RFC} (I_{DD})$ interval; CKE is HIGH, S# is HIGH between valid commands; Other control and address bus inputs are SWITCHING; Data bus inputs are SWITCHING.	$I_{DD5}^b$	2,720	2,640	mA	
<b>Self refresh current;</b> CK and CK# at 0V; CKE ≤ 0.2V; Other control and address bus inputs are FLOATING; Data bus inputs are FLOATING.	$I_{DD6}^b$	80	80	mA	
<b>Operating device bank interleave read current;</b> All device banks interleaving reads, $I_{OUT} = 0\text{mA}$ ; BL = 4, CL = CL (I <sub>DD</sub> ), AL = $t_{RCD} (I_{DD}) - 1 \times t_{CK} (I_{DD})$ ; $t_{CK} = t_{CK} (I_{DD})$ , $t_{RC} = t_{RC}(I_{DD})$ , $t_{RRD} = t_{RRD}(I_{DD})$ , $t_{RCD} = t_{RCD}(I_{DD})$ ; CKE is HIGH, S# is HIGH between valid commands; Address bus inputs are STABLE during DESELECTs; Data bus inputs are SWITCHING; See I <sub>DD7</sub> Conditions for detail.	$I_{DD7}^a$	1,960	1,880	mA	

NOTE:

- a: Value calculated as one module rank in this operating condition, and all other module ranks in I<sub>DD2P</sub> (CKE LOW) mode.
- b: Value calculated reflects all module ranks in this operating condition.

**Table 16: DDR2 IDD Specifications and Conditions – 1GB**

Notes: 1–5; notes appear on page 28. Values shown for DDR2 SDRAM components only.

PARAMETER/CONDITION	SYMBOL	-53E	-40E	UNITS
<b>Operating one device bank active-precharge current;</b> $t_{CK} = t_{CK} (I_{DD})$ , $t_{RC} = t_{RC} (I_{DD})$ , $t_{RAS} = t_{RAS} \text{ MIN} (I_{DD})$ ; CKE is HIGH, S# is HIGH between valid commands; Address bus inputs are SWITCHING; Data bus inputs are SWITCHING.	$I_{DD0}^a$	680	640	mA
<b>Operating one device bank active-read-precharge current;</b> $I_{OUT} = 0\text{mA}$ ; BL = 4, CL = CL(I <sub>DD</sub> ), AL = 0; $t_{CK} = t_{CK} (I_{DD})$ , $t_{RC} = t_{RC} (I_{DD})$ , $t_{RAS} = t_{RAS} \text{ MIN} (I_{DD})$ , $t_{RCD} = t_{RCD} (I_{DD})$ ; CKE is HIGH, S# is HIGH between valid commands; Address bus inputs are SWITCHING; Data pattern is same as I <sub>DD4W</sub> .	$I_{DD1}^a$	760	720	mA
<b>Precharge power-down current;</b> All device banks idle; $t_{CK} = t_{CK} (I_{DD})$ ; CKE is LOW; Other control and address bus inputs are STABLE; Data bus inputs are FLOATING.	$I_{DD2P}^b$	80	80	mA
<b>Precharge quiet standby current;</b> All device banks idle; $t_{CK} = t_{CK} (I_{DD})$ ; CKE is HIGH, S# is HIGH; Other control and address bus inputs are STABLE; Data bus inputs are FLOATING.	$I_{DD2Q}^b$	560	400	mA
<b>Precharge standby current;</b> All device banks idle; $t_{CK} = t_{CK} (I_{DD})$ ; CKE is HIGH, S# is HIGH; Other control and address bus inputs are SWITCHING; Data bus inputs are SWITCHING.	$I_{DD2N}^b$	560	480	mA
<b>Active power-down current;</b> All device banks open; $t_{CK} = t_{CK} (I_{DD})$ ; CKE is LOW; Other control and address bus inputs are STABLE; Data bus inputs are FLOATING.	Fast PDN Exit MR[12] = 0	400	320	mA
	Slow PDN Exit MR[12] = 1	96	96	mA
<b>Active standby current;</b> All device banks open; $t_{CK} = t_{CK}(I_{DD})$ , $t_{RAS} = t_{RAS} \text{ MAX} (I_{DD})$ , $t_{RP} = t_{RP}(I_{DD})$ ; CKE is HIGH, S# is HIGH between valid commands; Other control and address bus inputs are SWITCHING; Data bus inputs are SWITCHING.	$I_{DD3N}^b$	640	480	mA
<b>Operating burst write current;</b> All device banks open, Continuous burst writes; BL = 4, CL = CL (I <sub>DD</sub> ), AL = 0; $t_{CK} = t_{CK} (I_{DD})$ , $t_{RAS} = t_{RAS} \text{ MAX} (I_{DD})$ , $t_{RP} = t_{RP} (I_{DD})$ ; CKE is HIGH, S# is HIGH between valid commands; Address bus inputs are SWITCHING; Data bus inputs are SWITCHING.	$I_{DD4W}^a$	1,320	1,040	mA
<b>Operating burst read current;</b> All device banks open, Continuous burst reads, $I_{OUT} = 0\text{mA}$ ; BL = 4, CL = CL (I <sub>DD</sub> ), AL = 0; $t_{CK} = t_{CK} (I_{DD})$ , $t_{RAS} = t_{RAS} \text{ MAX} (I_{DD})$ , $t_{RP} = t_{RP} (I_{DD})$ ; CKE is HIGH, S# is HIGH between valid commands; Address bus inputs are SWITCHING; Data bus inputs are SWITCHING.	$I_{DD4R}^a$	1,240	960	mA
<b>Burst refresh current;</b> $t_{CK} = t_{CK} (I_{DD})$ ; Refresh command at every $t_{RFC} (I_{DD})$ interval; CKE is HIGH, S# is HIGH between valid commands; Other control and address bus inputs are SWITCHING; Data bus inputs are SWITCHING.	$I_{DD5}^b$	2,720	2,640	mA
<b>Self refresh current;</b> CK and CK# at 0V; CKE ≤ 0.2V; Other control and address bus inputs are FLOATING; Data bus inputs are FLOATING.	$I_{DD6}^b$	80	80	mA
<b>Operating device bank interleave read current;</b> All device banks interleaving reads, $I_{OUT} = 0\text{mA}$ ; BL = 4, CL = CL (I <sub>DD</sub> ), AL = $t_{RCD} (I_{DD}) - 1 \times t_{CK} (I_{DD})$ ; $t_{CK} = t_{CK} (I_{DD})$ , $t_{RC} = t_{RC}(I_{DD})$ , $t_{RRD} = t_{RRD}(I_{DD})$ , $t_{RCD} = t_{RCD}(I_{DD})$ ; CKE is HIGH, S# is HIGH between valid commands; Address bus inputs are STABLE during DESELECTs; Data bus inputs are SWITCHING; See I <sub>DD7</sub> Conditions for detail.	$I_{DD7}^a$	1,960	1,880	mA

NOTE:

- a: Value calculated as one module rank in this operating condition, and all other module ranks in I<sub>DD2P</sub> (CKE LOW) mode.
- b: Value calculated reflects all module ranks in this operating condition.

**Table 17: DDR2 IDD Specifications and Conditions – 2GB**

Notes: 1–5; notes appear on page 28; values shown for DDR2 SDRAM components only

PARAMETER/CONDITION	SYMBOL	-53E	-40E	UNITS	
<b>Operating one device bank active-precharge current;</b> $t_{CK} = t_{CK} (I_{DD})$ , $t_{RC} = t_{RC} (I_{DD})$ , $t_{RAS} = t_{RAS} \text{ MIN} (I_{DD})$ ; CKE is HIGH, S# is HIGH between valid commands; Address bus inputs are SWITCHING; Data bus inputs are SWITCHING.	$I_{DD0}^a$	680	680	mA	
<b>Operating one device bank active-read-precharge current;</b> $I_{OUT} = 0\text{mA}$ ; BL = 4, CL = CL(I <sub>DD</sub> ), AL = 0; $t_{CK} = t_{CK} (I_{DD})$ , $t_{RC} = t_{RC} (I_{DD})$ , $t_{RAS} = t_{RAS} \text{ MIN} (I_{DD})$ , $t_{RCD} = t_{RCD} (I_{DD})$ ; CKE is HIGH, S# is HIGH between valid commands; Address bus inputs are SWITCHING; Data pattern is same as I <sub>DD4W</sub> .	$I_{DD1}^a$	800	800	mA	
<b>Precharge power-down current;</b> All device banks idle; $t_{CK} = t_{CK} (I_{DD})$ ; CKE is LOW; Other control and address bus inputs are STABLE; Data bus inputs are FLOATING.	$I_{DD2P}^b$	80	80	mA	
<b>Precharge quiet standby current;</b> All device banks idle; $t_{CK} = t_{CK} (I_{DD})$ ; CKE is HIGH, S# is HIGH; Other control and address bus inputs are STABLE; Data bus inputs are FLOATING.	$I_{DD2Q}^b$	656	560	mA	
<b>Precharge standby current;</b> All device banks idle; $t_{CK} = t_{CK} (I_{DD})$ ; CKE is HIGH, S# is HIGH; Other control and address bus inputs are SWITCHING; Data bus inputs are SWITCHING.	$I_{DD2N}^b$	720	560	mA	
<b>Active power-down current;</b> All device banks open; $t_{CK} = t_{CK} (I_{DD})$ ; CKE is LOW; Other control and address bus inputs are STABLE; Data bus inputs are FLOATING.	$I_{DD3P}^b$	Fast PDN Exit MR[12] = 0	480	400	mA
		Slow PDN Exit MR[12] = 1	80	80	mA
<b>Active standby current;</b> All device banks open; $t_{CK} = t_{CK}(I_{DD})$ , $t_{RAS} = t_{RAS} \text{ MAX} (I_{DD})$ , $t_{RP} = t_{RP}(I_{DD})$ ; CKE is HIGH, S# is HIGH between valid commands; Other control and address bus inputs are SWITCHING; Data bus inputs are SWITCHING.	$I_{DD3N}^b$	800	640	mA	
<b>Operating burst write current;</b> All device banks open, Continuous burst writes; BL = 4, CL = CL (I <sub>DD</sub> ), AL = 0; $t_{CK} = t_{CK} (I_{DD})$ , $t_{RAS} = t_{RAS} \text{ MAX} (I_{DD})$ , $t_{RP} = t_{RP} (I_{DD})$ ; CKE is HIGH, S# is HIGH between valid commands; Address bus inputs are SWITCHING; Data bus inputs are SWITCHING.	$I_{DD4W}^a$	1,080	1,000	mA	
<b>Operating burst read current;</b> All device banks open, Continuous burst reads, $I_{OUT} = 0\text{mA}$ ; BL = 4, CL = CL (I <sub>DD</sub> ), AL = 0; $t_{CK} = t_{CK} (I_{DD})$ , $t_{RAS} = t_{RAS} \text{ MAX} (I_{DD})$ , $t_{RP} = t_{RP} (I_{DD})$ ; CKE is HIGH, S# is HIGH between valid commands; Address bus inputs are SWITCHING; Data bus inputs are SWITCHING.	$I_{DD4R}^a$	1,200	1,120	mA	
<b>Burst refresh current;</b> $t_{CK} = t_{CK} (I_{DD})$ ; Refresh command at every $t_{RFC} (I_{DD})$ interval; CKE is HIGH, S# is HIGH between valid commands; Other control and address bus inputs are SWITCHING; Data bus inputs are SWITCHING.	$I_{DD5}^b$	4,000	3,840	mA	
<b>Self refresh current;</b> CK and CK# at 0V; CKE ≤ 0.2V; Other control and address bus inputs are FLOATING; Data bus inputs are FLOATING.	$I_{DD6}^b$	80	80	mA	
<b>Operating device bank interleave read current;</b> All device banks interleaving reads, $I_{OUT} = 0\text{mA}$ ; BL = 4, CL = CL (I <sub>DD</sub> ), AL = $t_{RCD} (I_{DD}) - 1 \times t_{CK} (I_{DD})$ ; $t_{CK} = t_{CK} (I_{DD})$ , $t_{RC} = t_{RC}(I_{DD})$ , $t_{RRD} = t_{RRD}(I_{DD})$ , $t_{RCD} = t_{RCD}(I_{DD})$ ; CKE is HIGH, S# is HIGH between valid commands; Address bus inputs are STABLE during DESELECTs; Data bus inputs are SWITCHING; See I <sub>DD7</sub> Conditions for detail.	$I_{DD7}^a$	2,400	2,400	mA	

NOTE:

- a: Value calculated as one module rank in this operating condition, and all other module ranks in I<sub>DD2P</sub> (CKE LOW) mode.
- b: Value calculated reflects all module ranks in this operating condition.

**Table 18: AC Operating Conditions (Sheet 1 of 4)**

 Notes: 1-5; notes appear on page 28; 0°C ≤ T<sub>CASE</sub> ≤ +85°C; V<sub>DDQ</sub> = +1.8V ±0.1V, V<sub>DD</sub> = +1.8V ±0.1V

AC CHARACTERISTICS					-53E		-40E			
PARAMETER			SYMBOL	MIN	MAX	MIN	MAX	UNITS	NOTES	
Clock	Clock cycle time	CL = 4	t <sub>CK</sub> (4)	3,750	8,000	5,000	8,000	ps	16, 25	
		CL = 3	t <sub>CK</sub> (3)	5,000	8,000	5,000	8,000	ps	16, 25	
	CK high-level width		t <sub>CH</sub>	0.45	0.55	0.45	0.55	t <sub>CK</sub>	19	
	CK low-level width		t <sub>CL</sub>	0.45	0.55	0.45	0.55	t <sub>CK</sub>	19	
	Half clock period		t <sub>HP</sub>	MIN (t <sub>CH</sub> , t <sub>CL</sub> )		MIN (t <sub>CH</sub> , t <sub>CL</sub> )		ps	20	
	Clock jitter		t <sub>JIT</sub>	TBD	TBD	TBD	TBD	ps	18	
Data	DQ output access time from CK/CK#		t <sub>AC</sub>	-500	+500	-600	+600	ps		
	Data-out high-impedance window from CK/CK#		t <sub>HZ</sub>		t <sub>AC</sub> MAX		t <sub>AC</sub> MAX	ps	8, 9	
	Data-out low-impedance window from CK/CK#		t <sub>LZ</sub>	t <sub>AC</sub> MIN	t <sub>AC</sub> MAX	t <sub>AC</sub> MIN	t <sub>AC</sub> MAX	ps	8, 10	
	DQ and DM input setup time relative to DQS		t <sub>DS<sub>a</sub></sub>	350		400		ps	7, 15, 22	
	DQ and DM input hold time relative to DQS		t <sub>DH<sub>a</sub></sub>	350		400		ps	7, 15, 22	
	DQ and DM input setup time relative to DQS		t <sub>DS<sub>b</sub></sub>	100		150		ps	7, 15, 22	
	DQ and DM input hold time relative to DQS		t <sub>DH<sub>b</sub></sub>	225		275		ps	7, 15, 22	
	DQ and DM input pulse width (for each input)		t <sub>DIPW</sub>	0.35		0.35		t <sub>CK</sub>		
	Data hold skew factor		t <sub>QHS</sub>		400		450	ps		
	DQ-DQS hold, DQS to first DQ to go nonvalid, per access		t <sub>QH</sub>	t <sub>HP</sub> - t <sub>QHS</sub>		t <sub>HP</sub> - t <sub>QHS</sub>		ps	15, 17	
	Data valid output window (DVW)		t <sub>DVW</sub>	t <sub>QH</sub> - t <sub>DQSQ</sub>		t <sub>QH</sub> - t <sub>DQSQ</sub>		ns	15, 17	



**Table 18: AC Operating Conditions (Sheet 2 of 4)**

Notes: 1-5; notes appear on page 28;  $0^{\circ}\text{C} \leq T_{\text{CASE}} \leq +85^{\circ}\text{C}$ ;  $V_{\text{DDQ}} = +1.8\text{V} \pm 0.1\text{V}$ ,  $V_{\text{DD}} = +1.8\text{V} \pm 0.1\text{V}$

AC CHARACTERISTICS			-53E		-40E			
PARAMETER		SYMBOL	MIN	MAX	MIN	MAX	UNITS	NOTES
Data Strobe	DQS input high pulse width	$t_{\text{DQSH}}$	0.35		0.35		$t_{\text{CK}}$	
	DQS input low pulse width	$t_{\text{DQSL}}$	0.35		0.35		$t_{\text{CK}}$	
	DQS output access time from CK/CK#	$t_{\text{DQSK}}$	-450	+450	-500	+500	ps	
	DQS falling edge to CK rising - setup time	$t_{\text{DSS}}$	0.2		0.2		$t_{\text{CK}}$	
	DQS falling edge from CK rising - hold time	$t_{\text{DSH}}$	0.2		0.2		$t_{\text{CK}}$	
	DQS-DQ skew, DQS to last DQ valid, per group, per access	$t_{\text{DQSQ}}$		300		350	ps	15, 17
	DQS read preamble	$t_{\text{RPRE}}$	0.9	1.1	0.9	1.1	$t_{\text{CK}}$	36
	DQS read postamble	$t_{\text{RPST}}$	0.4	0.6	0.4	0.6	$t_{\text{CK}}$	36
	DQS write preamble setup time	$t_{\text{WPRES}}$	0		0		ps	12, 13
	DQS write preamble	$t_{\text{WPRE}}$	0.25		0.25		$t_{\text{CK}}$	
	DQS write postamble	$t_{\text{WPST}}$	0.4	0.6	0.4	0.6	$t_{\text{CK}}$	11
	Write command to first DQS latching transition	$t_{\text{DQSS}}$	WL - 0.25	WL + 0.25	WL - 0.25	WL + 0.25	$t_{\text{CK}}$	

**Table 18: AC Operating Conditions (Sheet 3 of 4)**

 Notes: 1-5; notes appear on page 28;  $0^{\circ}\text{C} \leq T_{\text{CASE}} \leq +85^{\circ}\text{C}$ ;  $V_{\text{DDQ}} = +1.8\text{V} \pm 0.1\text{V}$ ,  $V_{\text{DD}} = +1.8\text{V} \pm 0.1\text{V}$ 

AC CHARACTERISTICS		-53E		-40E			
PARAMETER	SYMBOL	MIN	MAX	MIN	MAX	UNITS	NOTES
Command and Address	Address and control input pulse width for each input	$t_{\text{IPW}}$	0.6		0.6		$t_{\text{CK}}$
	Address and control input setup time	$t_{\text{IS}_a}$	500		600		ps, 6, 22
	Address and control input hold time	$t_{\text{IH}_a}$	500		600		ps, 6, 22
	Address and control input setup time	$t_{\text{IS}_b}$	250		350		ps, 6, 22
	Address and control input hold time	$t_{\text{IH}_b}$	375		475		ps, 6, 22
	CAS# to CAS# command delay	$t_{\text{CCD}}$	2		2		$t_{\text{CK}}$
	ACTIVE to ACTIVE (same bank) command	$t_{\text{RC}}$	55		55		ns, 34
	ACTIVE bank <i>a</i> to ACTIVE bank <i>b</i> command	$t_{\text{RRD}}$	7.5		7.5		ns, 28
	ACTIVE to READ or WRITE delay	$t_{\text{RCD}}$	15		15		ns
	Four Bank Activate period	$t_{\text{FAW}}$	37.5		37.5		ns, 31
	ACTIVE to PRECHARGE command	$t_{\text{RAS}}$	40	70,000	40	70,000	ns, 21, 34
	Internal READ to precharge command delay	$t_{\text{RTP}}$	7.5		7.5		ns, 24, 28
	Write recovery time	$t_{\text{WR}}$	15		15		ns, 28
	Auto precharge write recovery + precharge time	$t_{\text{DAL}}$	$t_{\text{WR}} + t_{\text{RP}}$		$t_{\text{WR}} + t_{\text{RP}}$		ns, 23
	Internal WRITE to READ command delay	$t_{\text{WTR}}$	7.5		10		ns, 28
	PRECHARGE command period	$t_{\text{RP}}$	15		15		ns, 32
	PRECHARGE ALL command period	$t_{\text{RPA}}$	$t_{\text{RP}} + t_{\text{CK}}$		$t_{\text{RP}} + t_{\text{CK}}$		ns, 32
	LOAD MODE command cycle time	$t_{\text{MRD}}$	2		2		$t_{\text{CK}}$
	CKE low to CK,CK# uncertainty	$t_{\text{DELAY}}$	4.375	4.375	5.83	5.83	ns, 29

**Table 18: AC Operating Conditions (Sheet 4 of 4)**

 Notes: 1–5; notes appear on page 28;  $0^{\circ}\text{C} \leq T_{\text{CASE}} \leq +85^{\circ}\text{C}$ ;  $V_{\text{DDQ}} = +1.8\text{V} \pm 0.1\text{V}$ ,  $V_{\text{DD}} = +1.8\text{V} \pm 0.1\text{V}$ 

AC CHARACTERISTICS			-53E		-40E			
PARAMETER		SYMBOL	MIN	MAX	MIN	MAX	UNITS	NOTES
Self Refresh	REFRESH to Active or Refresh to Refresh command interval	$t_{\text{RFC}}$ (512MB)	75	70,000	75	70,000	ns	14
		$t_{\text{RFC}}$ (1GB)	105	70,000	105	70,000	ns	14
		$t_{\text{RFC}}$ (2GB)	127.5	70,000	127.5	70,000	ns	14
	Average periodic refresh interval	$t_{\text{REFI}}$		7.8		7.8	$\mu\text{s}$	14
	Exit self refresh to non-READ command	$t_{\text{XSNR}}$	$t_{\text{RFC}}$ (MIN) + 10		$t_{\text{RFC}}$ (MIN) + 10		ns	
	Exit self refresh to READ command	$t_{\text{XSRD}}$	200		200		$t_{\text{CK}}$	
	Exit self refresh timing reference	$t_{\text{ISXR}}$	250		350		ps	6, 30
ODT	ODT turn-on delay	$t_{\text{AOND}}$	2	2	2	2	$t_{\text{CK}}$	
	ODT turn-on	$t_{\text{AON}}$	$t_{\text{AC}}$ (MIN)	$t_{\text{AC}}$ (MAX) + 1,000	$t_{\text{AC}}$ (MIN)	$t_{\text{AC}}$ (MAX) + 1000	ps	26
	ODT turn-off delay	$t_{\text{AOFD}}$	2.5	2.5	2.5	2.5	$t_{\text{CK}}$	
	ODT turn-off	$t_{\text{AOF}}$	$t_{\text{AC}}$ (MIN)	$t_{\text{AC}}$ (MAX) + 600	$t_{\text{AC}}$ (MIN)	$t_{\text{AC}}$ (MAX) + 600	ps	27
	ODT turn-on (power-down mode)	$t_{\text{AONPD}}$	$t_{\text{AC}}$ (MIN) + 2000	$2 \times t_{\text{CK}} + t_{\text{AC}}$ (MAX) + 1,000	$t_{\text{AC}}$ (MIN) + 2,000	$2 \times t_{\text{CK}} + t_{\text{AC}}$ (MAX) + 1000	ps	
	ODT turn-off (power-down mode)	$t_{\text{AOFPD}}$	$t_{\text{AC}}$ (MIN) + 2,000	$2.5 \times t_{\text{CK}} + t_{\text{AC}}$ (MAX) + 1,000	$t_{\text{AC}}$ (MIN) + 2,000	$2.5 \times t_{\text{CK}} + t_{\text{AC}}$ (MAX) + 1,000	ps	
	ODT to power-down entry latency	$t_{\text{ANPD}}$	3		3		$t_{\text{CK}}$	
	ODT power-down exit latency	$t_{\text{AXPD}}$	8		8		$t_{\text{CK}}$	
Power-Down	Exit active power-down to READ command, MR[bit12=0]	$t_{\text{XARD}}$	2		2		$t_{\text{CK}}$	
	Exit active power-down to READ command, MR[bit12=1]	$t_{\text{XARDS}}$	6 - AL		6 - AL		$t_{\text{CK}}$	
	Exit precharge power-down to any non-READ command.	$t_{\text{XP}}$	2		2		$t_{\text{CK}}$	
	Exit precharge power-down to READ command.	$t_{\text{XPRD}}$	6 - AL		6 - AL		$t_{\text{CK}}$	
	CKE minimum high/low time	$t_{\text{CKE}}$	3		3		$t_{\text{CK}}$	35

## Notes

1. All voltages referenced to VSS.
2. Tests for AC timing, I<sub>DD</sub>, and electrical AC and DC characteristics may be conducted at nominal reference/supply voltage levels, but the related specifications and device operation are guaranteed for the full voltage range specified.
3. Outputs measured with equivalent load:

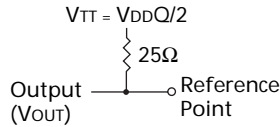

4. AC timing and I<sub>DD</sub> tests may use a V<sub>IL</sub>-to-V<sub>IH</sub> swing of up to 1.0V in the test environment and parameter specifications are guaranteed for the specified AC input levels under normal use conditions. The minimum slew rate for the input signals used to test the device is 1.0V/ns for signals in the range between V<sub>IL</sub> (AC) and V<sub>IH</sub> (AC). Slew rates less than 1.0V/ns require the timing parameters to be derated as specified.
5. The AC and DC input level specifications are as defined in the SSTL\_18 standard (i.e., the receiver will effectively switch as a result of the signal crossing the AC input level and will remain in that state as long as the signal does not ring back above [below] the DC input LOW [HIGH] level).
6. Command/Address minimum input slew rate is at 1.0V/ns. Command/Address input timing must be derated if the slew rate is not 1.0V/ns. This is easily accommodated using <sup>t</sup>IS<sub>b</sub> and the Setup and Hold Time Derating Values table. <sup>t</sup>IS timing (<sup>t</sup>IS<sub>b</sub>) is referenced from V<sub>IH</sub> (AC) for a rising signal and V<sub>IL</sub>(AC) for a falling signal. <sup>t</sup>IH timing (<sup>t</sup>IH<sub>b</sub>) is referenced from V<sub>IH</sub>(AC) for a rising signal and V<sub>IL</sub>(DC) for a falling signal. The timing table also lists the <sup>t</sup>IS<sub>b</sub> and <sup>t</sup>IH<sub>b</sub> values for a 1.0V/ns slew rate; these are the “base” values.
7. Data minimum input slew rate is at 1.0V/ns. Data input timing must be derated if the slew rate is not 1.0V/ns. This is easily accommodated if the timing is referenced from the logic trip points. <sup>t</sup>DS timing (<sup>t</sup>DS<sub>b</sub>) is referenced from V<sub>IH</sub> (AC) for a rising signal and V<sub>IL</sub> (AC) for a falling signal. <sup>t</sup>IH timing (<sup>t</sup>IH<sub>b</sub>) is referenced from V<sub>IH</sub>(DC) for a rising signal and V<sub>IL</sub>(DC) for a falling signal. The timing table lists the <sup>t</sup>DS<sub>b</sub> and <sup>t</sup>DH<sub>b</sub> values for a 1.0V/ns slew rate. If the DQS/DQS# differential strobe feature is not enabled, timing is no longer referenced to the crosspoint of DQS/DQS#. Data timing is now referenced to V<sub>REF</sub>, provided the DQS slew

rate is not less than 1.0V/ns. If the DQS slew rate is less than 1.0V/ns, then data timing is now referenced to V<sub>IH</sub>(AC) for a rising DQS and V<sub>IL</sub>(DC) for a falling DQS.

8. <sup>t</sup>HZ and <sup>t</sup>LZ transitions occur in the same access time windows as valid data transitions. These parameters are not referenced to a specific voltage level, but specify when the device output is no longer driving (<sup>t</sup>HZ) or begins driving (<sup>t</sup>LZ).
9. This maximum value is derived from the referenced test load. <sup>t</sup>HZ (MAX) will prevail over <sup>t</sup>DQSCK (MAX) + <sup>t</sup>RPST (MAX) condition.
10. <sup>t</sup>LZ (MIN) will prevail over a <sup>t</sup>DQSCK (MIN) + <sup>t</sup>RPRE (MAX) condition.
11. The intent of the Don't Care state after completion of the postamble is the DQS-driven signal should either be high, low or High-Z and that any signal transition within the input switching region must follow valid input requirements. That is if DQS transitions high (above V<sub>IH</sub>(DC)) then it must not transition low (below V<sub>IH</sub>(DC)) prior to <sup>t</sup>DQSH(min).
12. This is not a device limit. The device will operate with a negative value, but system performance could be degraded due to bus turnaround.
13. It is recommended that DQS be valid (HIGH or LOW) on or before the WRITE command. The case shown (DQS going from High-Z to logic LOW) applies when no WRITES were previously in progress on the bus. If a previous WRITE was in progress, DQS could be HIGH during this time, depending on <sup>t</sup>DQSS.
14. The refresh period is 64ms. This equates to an average refresh rate of 7.8125μs. However, a REFRESH command must be asserted at least once every 70.3μs or <sup>t</sup>RFC (MAX). To ensure all rows of all banks are properly refreshed, 8192 REFRESH commands must be issued every 64ms.
15. Each byte lane has a corresponding DQS.
16. CK and CK# input slew rate must be ≥ 1V/ns (≥ 2 V/ns if measured differentially).
17. The data valid window is derived by achieving other specifications - <sup>t</sup>HP, (<sup>t</sup>CK/2), <sup>t</sup>DQSQ, and <sup>t</sup>QH (<sup>t</sup>QH = <sup>t</sup>HP - <sup>t</sup>QHS). The data valid window derates in direct proportion to the clock duty cycle and a practical data valid window can be derived.
18. <sup>t</sup>JIT specification is currently TBD.
19. MIN(<sup>t</sup>CL, <sup>t</sup>CH) refers to the smaller of the actual clock low time and the actual clock high time as provided to the device (i.e. This value can be greater than the minimum specification limits for

- <sup>t</sup>CL and <sup>t</sup>CH). For example, <sup>t</sup>CL and <sup>t</sup>CH are = 50 percent of the period, less the half period jitter [<sup>t</sup>JIT(HP)] of the clock source, and less the half period jitter due to cross talk [<sup>t</sup>JIT(cross talk)] into the clock traces.
20. <sup>t</sup>HP (MIN) is the lesser of <sup>t</sup>CL minimum and <sup>t</sup>CH minimum actually applied to the device CK and CK# inputs.
  21. READs and WRITEs with auto precharge are allowed to be issued before <sup>t</sup>RAS (MIN) is satisfied since <sup>t</sup>RAS lockout feature is supported in DDR2 SDRAM devices.
  22. VIL/VIH DDR2 overshoot/undershoot. REFER TO the 256Mb, 512Mb, or 1Gb DDR2 SDRAM data sheet for more detail.
  23. <sup>t</sup>DAL = (nWR) + (<sup>t</sup>RP/<sup>t</sup>CK): For each of the terms above, if not already an integer, round to the next highest integer. <sup>t</sup>CK refers to the application clock period; nWR refers to the <sup>t</sup>WR parameter stored in the MR[11,10,9]. Example: For -53E at <sup>t</sup>CK = 3.75 ns with <sup>t</sup>WR programmed to four clocks. <sup>t</sup>DAL = 4 + (15 ns/3.75 ns) clocks = 4 + (4) clocks = 8 clocks.
  24. The minimum READ to internal PRECHARGE time. This parameter is only applicable when <sup>t</sup>RTP/(2\*<sup>t</sup>CK) > 1. If <sup>t</sup>RTP/(2\*<sup>t</sup>CK) ≤ 1, then equation AL + BL/2 applies. Notwithstanding, <sup>t</sup>RAS (MIN) has to be satisfied as well. The DDR2 SDRAM device will automatically delay the internal PRECHARGE command until <sup>t</sup>RAS (MIN) has been satisfied.
  25. Operating frequency is only allowed to change during self refresh mode, precharge power-down mode, and system reset condition.
  26. ODT turn-on time <sup>t</sup>AON (MIN) is when the device leaves high impedance and ODT resistance begins to turn on. ODT turn-on time <sup>t</sup>AON (MAX) is when the ODT resistance is fully on. Both are measured from <sup>t</sup>AOND.
  27. ODT turn-off time <sup>t</sup>AOF (MIN) is when the device starts to turn off ODT resistance. ODT turn off time <sup>t</sup>AOF (MAX) is when the bus is in high impedance. Both are measured from <sup>t</sup>AOFD.
  28. This parameter has a two clock minimum requirement at any <sup>t</sup>CK.
  29. <sup>t</sup>DELAY is calculated from <sup>t</sup>IS + <sup>t</sup>CK + <sup>t</sup>IH so that CKE registration LOW is guaranteed prior to CK, CK# being removed in a system RESET condition.
  30. <sup>t</sup>ISXR is equal to <sup>t</sup>IS and is used for CKE setup time during self refresh exit.
  31. No more than 4 bank ACTIVE commands may be issued in a given <sup>t</sup>FAW(min) period. <sup>t</sup>RRD(min) restriction still applies. The <sup>t</sup>FAW(min) parameter applies to all 8 bank DDR2 devices, regardless of the number of banks already open or closed.
  32. <sup>t</sup>RPA timing applies when the PRECHARGE(ALL) command is issued, regardless of the number of banks already open or closed. If a single-bank PRECHARGE command is issued, <sup>t</sup>RP timing applies. <sup>t</sup>RPA(MIN) applies to all 8-bank DDR2 devices.
  33. Value is minimum pulse width, not the number of clock registrations.
  34. Applicable to Read cycles only. Write cycles generally require additional time due to Write recovery time (<sup>t</sup>WR) during auto precharge.
  35. <sup>t</sup>CKE (MIN) of 3 clocks means CKE must be registered on three consecutive positive clock edges. CKE must remain at the valid input level the entire time it takes to achieve the 3 clocks of registration. Thus, after any CKE transition, CKE may not transition from its valid level during the time period of <sup>t</sup>IS + 2 \* <sup>t</sup>CK + <sup>t</sup>IH.
  36. This parameter is not referenced to a specific voltage level, but specified when the device output is no longer driving (<sup>t</sup>RPST) or beginning to drive (<sup>t</sup>RPRE).

### SPD Clock and Data Conventions

Data states on the SDA line can change only during SCL LOW. SDA state changes during SCL HIGH are reserved for indicating start and stop conditions (Figure 12, Data Validity, and Figure 13, Definition of Start and Stop).

### SPD Start Condition

All commands are preceded by the start condition, which is a HIGH-to-LOW transition of SDA when SCL is HIGH. The SPD device continuously monitors the SDA and SCL lines for the start condition and will not respond to any command until this condition has been met.

### SPD Stop Condition

All communications are terminated by a stop condition, which is a LOW-to-HIGH transition of SDA when SCL is HIGH. The stop condition is also used to place the SPD device into standby power mode.

### SPD Acknowledge

Acknowledge is a software convention used to indicate successful data transfers. The transmitting device, either master or slave, will release the bus after transmitting eight bits. During the ninth clock cycle, the receiver will pull the SDA line LOW to acknowledge that it received the eight bits of data (Figure 14, Acknowledge Response From Receiver).

The SPD device will always respond with an acknowledge after recognition of a start condition and its slave address. If both the device and a WRITE operation have been selected, the SPD device will respond with an acknowledge after the receipt of each subsequent eight-bit word. In the read mode the SPD device will transmit eight bits of data, release the SDA line and monitor the line for an acknowledge. If an acknowledge is detected and no stop condition is generated by the master, the slave will continue to transmit data. If an acknowledge is not detected, the slave will terminate further data transmissions and await the stop condition to return to standby power mode.

Figure 12: Data Validity

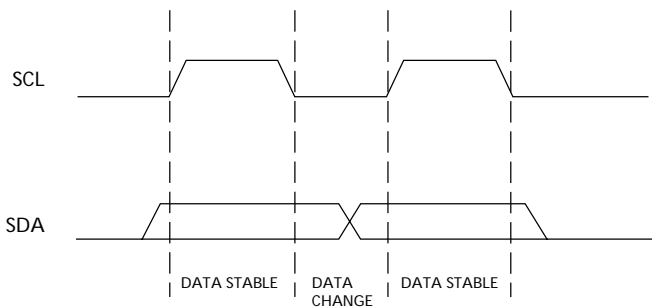

Figure 13: Definition of Start and Stop

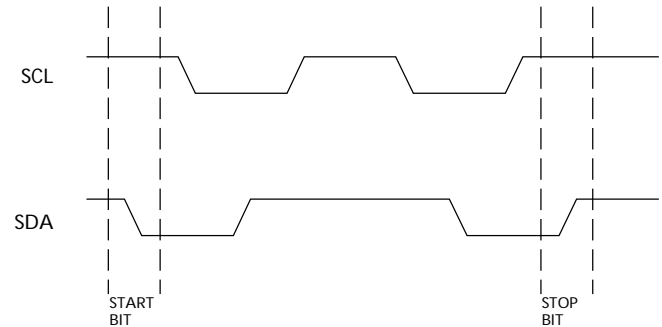
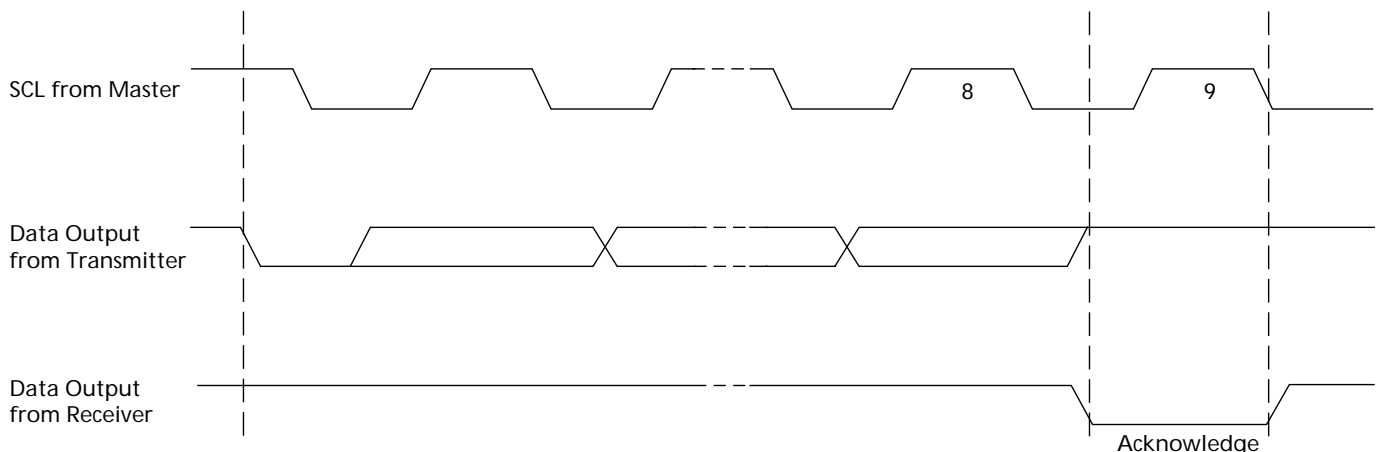

Figure 14: Acknowledge Response From Receiver



**Table 19: EEPROM Device Select Code**

The most significant bit (b7) is sent first

SELECT CODE	DEVICE TYPE IDENTIFIER				CHIP ENABLE			$\overline{RW}$
	b7	b6	b5	b4	b3	b2	b1	b0
Memory Area Select Code (two arrays)	1	0	1	0	SA2	SA1	SA0	$\overline{RW}$
Protection Register Select Code	0	1	1	0	SA2	SA1	SA0	$\overline{RW}$

**Table 20: EEPROM Operating Modes**

MODE	$\overline{RW}$ BIT	$\overline{WC}$	BYTES	INITIAL SEQUENCE
Current Address Read	1	V <sub>IH</sub> or V <sub>IL</sub>	1	START, Device Select, $\overline{RW}$ = '1'
Random Address Read	0	V <sub>IH</sub> or V <sub>IL</sub>	1	START, Device Select, $\overline{RW}$ = '0', Address
	1	V <sub>IH</sub> or V <sub>IL</sub>	1	reSTART, Device Select, $\overline{RW}$ = '1'
Sequential Read	1	V <sub>IH</sub> or V <sub>IL</sub>	≥ 1	Similar to Current or Random Address Read
Byte Write	0	V <sub>IL</sub>	1	START, Device Select, $\overline{RW}$ = '0'
Page Write	0	V <sub>IL</sub>	≤ 16	START, Device Select, $\overline{RW}$ = '0'

**Figure 15: SPD EEPROM Timing Diagram**

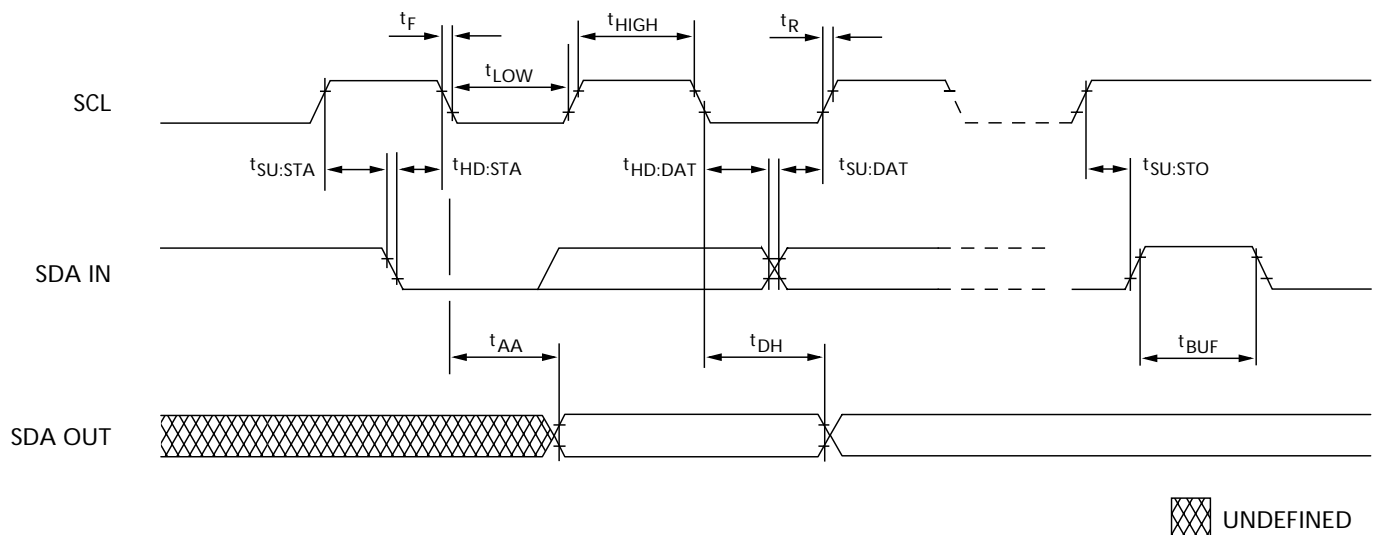

**Table 21: Serial Presence-Detect EEPROM DC Operating Conditions**

 All voltages referenced to V<sub>SS</sub>; V<sub>DDSPD</sub> = +1.7V to +3.6V

PARAMETER/CONDITION	SYMBOL	MIN	MAX	UNITS
Supply Voltage	V <sub>DDSPD</sub>	1.7	3.6	V
Input High Voltage: Logic 1; All inputs	V <sub>IH</sub>	V <sub>DDSPD</sub> x 0.7	V <sub>DDSPD</sub> + 0.5	V
Input Low Voltage: Logic 0; All inputs	V <sub>IL</sub>	-0.6	V <sub>DDSPD</sub> x 0.3	V
Output Low Voltage: I <sub>OUT</sub> = 3mA	V <sub>OL</sub>	-	0.4	V
Input Leakage Current: V <sub>IN</sub> = GND to V <sub>DD</sub>	I <sub>LI</sub>	0.10	3	μA
Output Leakage Current: V <sub>OUT</sub> = GND to V <sub>DD</sub>	I <sub>LO</sub>	0.05	3	μA
Standby Current:	I <sub>SB</sub>	1.6	4	μA
Power Supply Current, READ: SCL clock frequency = 100 KHz	I <sub>CC<sub>R</sub></sub>	0.4	1	mA
Power Supply Current, WRITE: SCL clock frequency = 100 KHz	I <sub>CC<sub>W</sub></sub>	2	3	mA

**Table 22: Serial Presence-Detect EEPROM AC Operating Conditions**

 All voltages referenced to V<sub>SS</sub>; V<sub>DDSPD</sub> = +1.7V to +3.6V

PARAMETER/CONDITION	SYMBOL	MIN	MAX	UNITS	NOTES
SCL LOW to SDA data-out valid	t <sup>AA</sup>	0.2	0.9	μs	1
Time the bus must be free before a new transition can start	t <sup>BUF</sup>	1.3		μs	
Data-out hold time	t <sup>DH</sup>	200		ns	
SDA and SCL fall time	t <sup>F</sup>		300	ns	2
Data-in hold time	t <sup>HD:DAT</sup>	0		μs	
Start condition hold time	t <sup>HD:STA</sup>	0.6		μs	
Clock HIGH period	t <sup>HIGH</sup>	0.6		μs	
Noise suppression time constant at SCL, SDA inputs	t <sup>I</sup>		50	ns	
Clock LOW period	t <sup>LOW</sup>	1.3		μs	
SDA and SCL rise time	t <sup>R</sup>		0.3	μs	2
SCL clock frequency	f <sup>SCL</sup>		400	KHz	
Data-in setup time	t <sup>SU:DAT</sup>	100		ns	
Start condition setup time	t <sup>SU:STA</sup>	0.6		μs	3
Stop condition setup time	t <sup>SU:STO</sup>	0.6		μs	
WRITE cycle time	t <sup>WRC</sup>		10	ms	4

NOTE:

1. To avoid spurious START and STOP conditions, a minimum delay is placed between SCL = 1 and the falling or rising edge of SDA.
2. This parameter is sampled.
3. For a reSTART condition, or following a WRITE cycle.
4. The SPD EEPROM WRITE cycle time (t<sup>WRC</sup>) is the time from a valid stop condition of a write sequence to the end of the EEPROM internal erase/program cycle. During the WRITE cycle, the EEPROM bus interface circuit is disabled, SDA remains HIGH due to pull-up resistor, and the EEPROM does not respond to its slave address.





**Table 23: Serial Presence-Detect Matrix**

"1"/"0": Serial Data, "driven to HIGH"/"driven to LOW"

BYTE	DESCRIPTION	ENTRY (VERSION)	MT16HTF6464A	MT16HTF12864A	MT16HTF25664A
0	Number of SPD Bytes Used by Micron	128	80	80	80
1	Total Number of Bytes in SPD Device	256	08	08	08
2	Fundamental Memory Type	DDR2 SDRAM	08	08	08
3	Number of Row Addresses on Assembly	13 or 14	0D	0E	0E
4	Number of Column Addresses on Assembly	10	0A	0A	0A
5	DIMM Height at Module Ranks	1.18in., Dual Rank	61	61	61
6	Module Data Width	64	40	40	40
7	Module Data Width (Continued)	0	00	00	00
8	Module Voltage Interface Levels	SSTL 1.8V	05	05	05
9	SDRAM Cycle Time, <sup>t</sup> CK (CAS Latency = 4)	-53E -40E	3D 50	3D 50	3D 50
10	SDRAM Access from Clock, <sup>t</sup> AC (CAS Latency = 4)	-53E -40E	50 60	50 60	50 60
11	Module Configuration Type	Unbuffered	00	00	00
12	Refresh Rate/Type	7.81µs/SELF	82	82	82
13	SDRAM Device Width (Primary SDRAM)	8	08	08	08
14	Error-checking SDRAM Data Width	N/A	00	00	00
15	Minimum Clock Delay, Back-to-Back Random Column Access	1 clock	00	00	00
16	Burst Lengths Supported	4, 8	0C	0C	0C
17	Number of Banks on SDRAM Device	4 or 8	04	04	08
18	CAS Latencies Supported	3, 4	18	18	18
19	Reserved	0	00	00	00
20	DDR2 DIMM Type	UDIMM	02	02	02
21	SDRAM Module Attributes		00	00	00
22	SDRAM Device Attributes: General	Weak Driver	01	01	01
23	SDRAM Cycle Time, <sup>t</sup> CK, (CAS Latency = 3)	-53E -40E	50 50	50 50	50 50
24	SDRAM Access from CK, <sup>t</sup> AC, (CAS Latency = 3)	-53E -40E	50 60	50 60	50 60
25	SDRAM Cycle Time, <sup>t</sup> CK, (CAS Latency = 2)	N/A	00	00	00
26	SDRAM Access from CK, <sup>t</sup> AC, (CAS Latency = 2)	N/A	00	00	00
27	Minimum Row Precharge Time, <sup>t</sup> RP	-53E/-40E	3C	3C	3C
28	Minimum Row Active to Row Active, <sup>t</sup> RRD	-53E/-40E	1E	1E	1E
29	Minimum RAS# to CAS# Delay, <sup>t</sup> RCD	-53E/-40E	3C	3C	3C
30	Minimum RAS# Pulse Width, <sup>t</sup> RAS	-53E -40E	2D 28	2D 28	2D 28
31	Module Rank Density	256MB, 512MB, 1GB	40	80	01
32	Address and Command Setup Time, <sup>t</sup> IS <sub>b</sub>	-53E -40E	25 35	25 35	25 35

**Table 23: Serial Presence-Detect Matrix**

"1"/"0": Serial Data, "driven to HIGH"/"driven to LOW"

BYTE	DESCRIPTION	ENTRY (VERSION)	MT16HTF6464A	MT16HTF12864A	MT16HTF25664A
33	Address and Command Hold Time, $t_{IH_b}$	-53E -40E	37 47	37 47	37 47
34	Data/ Data Mask Input Setup Time, $t_{DS_b}$	-53E -40E	10 15	10 15	10 15
35	Data/ Data Mask Input Hold Time, $t_{DH_b}$	-53E -40E	22 27	22 27	22 27
36	Write Recovery Time, $t_{WR}$		3C	3C	3C
37	Write to Read CMD Delay, $t_{WTR}$	-53E -40E	1E 28	1E 28	1E 28
38	Read to Precharge CMD Delay, $t_{RTP}$		1E	1E	1E
39	Mem Analysis Probe		00	00	00
40	Extension for bytes 41 and 42		00	00	06
41	Min Active Auto Refresh Time, $t_{RC}$	-53E -40E	3C 37	3C 37	3C 37
42	Minimum Auto Refresh to Active/ Auto Refresh Command Period, $t_{RFC}$		4B	69	7F
43	SDRAM Device Max Cycle Time, $t_{CKMAX}$		80	80	80
44	SDRAM Device Max DQS-DQ Skew Time, $t_{DQSQ}$	-53E -40E	1E 23	1E 23	1E 23
45	SDRAM Device Max Read Data Hold Skew Factor, $t_{QHS}$	-53E -40E	28 2D	28 2D	28 2D
46	PLL Relock Time		00	00	00
47-61	Optional features, not supported		00	00	00
62	SPD Revision	Release 1.1	11	11	11
63	Checksum For Bytes -62	-53E -40E	96 FD	F5 5C	96 FD
64	Manufacturer's JEDEC ID Code	MICRON	2C	2C	2C
65-71	Manufacturer's JEDEC ID Code	(Continued)	FF	FF	FF
72	Manufacturing Location	01-12	01-0C	01-0C	01-0C
73-90	Module Part Number (ASCII)		Variable Data	Variable Data	Variable Data
91	PCB Identification Code	1-9	01-09	01-09	01-09
92	Identification Code (Continued)	0	00	00	00
93	Year of Manufacture in BCD		Variable Data	Variable Data	Variable Data
94	Week of Manufacture in BCD		Variable Data	Variable Data	Variable Data
95-98	Module Serial Number		Variable Data	Variable Data	Variable Data
99-127	Manufacturer-Specific Data (RSVD)		-	-	-

Figure 16: 240-pin DIMM DDR2 Module Dimensions

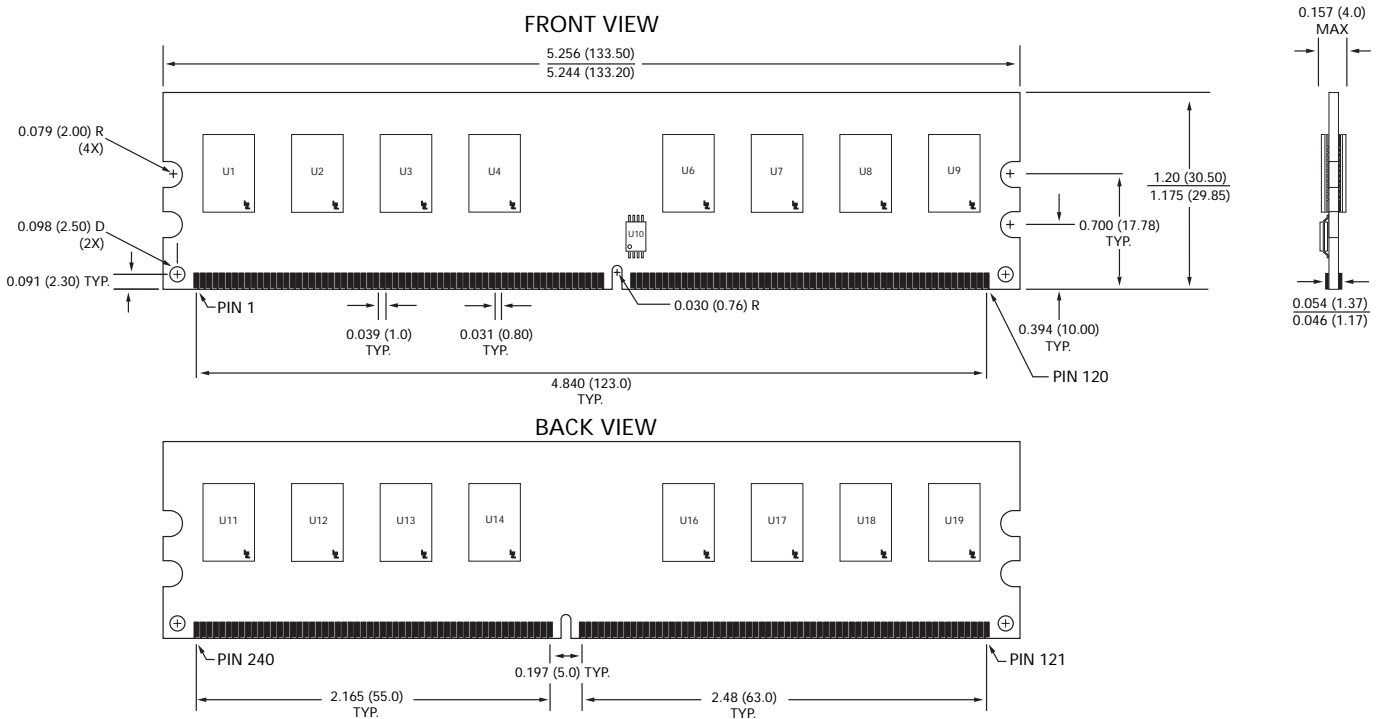

NOTE:

All dimensions are in inches (millimeters);  $\frac{\text{MAX}}{\text{MIN}}$  or typical where noted.

### Data Sheet Designation

**Preliminary:** Initial characterization limits, subject to change upon full characterization of production devices. The Preliminary designation applies to MT16HTF12864A and MT16HTF25664A only.

**Released (No Mark):** This data sheet contains minimum and maximum limits specified over the complete

power supply and temperature range for production devices. Although considered final, these specifications are subject to change, as further product development and data characterization sometimes occur. The Released designation applies to MT16HTF6464A only.



8000 S. Federal Way, P.O. Box 6, Boise, ID 83707-0006, Tel: 208-368-3900

E-mail: [prodmktg@micron.com](mailto:prodmktg@micron.com), Internet: <http://www.micron.com>, Customer Comment Line: 800-932-4992

Micron, the M logo, and the Micron logo are trademarks and/or service marks of Micron Technology, Inc.

All other trademarks are the property of their respective owners.