

LM3203

Step-Down DC-DC Converter with Bypass Mode for CDMA / WCDMA RF Power Amplifiers

General Description

The LM3203 is a DC-DC converter optimized for powering RF power amplifiers (PAs) from a single Lithium-Ion cell. However, they may be used in many other applications. It steps down an input voltage of 2.7V to 5.5V to an adjustable output voltage of 0.8V to 3.6V. The output voltage is set using a V_{CON} analog input and external resistor dividers for optimizing efficiency of the RF PA at various power levels.

The LM3203 offers 3 modes for mobile phones and similar RF PA applications. Fixed-frequency PWM mode minimizes RF interference. Bypass mode turns on an internal bypass switch to power the PA directly from the battery. Shutdown mode turns the device off and reduces battery consumption to 0.1 μ A (typ.).

The LM3203 is available in a 10-pin lead free micro SMD package. A high switching frequency (2MHz) allows use of tiny surface-mount components.

Features

- 2MHz (typ.) PWM Switching Frequency
- Operates from a single Li-Ion cell (2.7V to 5.5V)
- Adjustable Output Voltage (0.8V to 3.6V)
- 500mA Maximum load capability (PWM and Bypass mode)
- PWM / Forced Bypass Mode
- Low $R_{DS(ON)}$ Bypass FET: 85m Ω (typ.)
- High Efficiency (96% typ. at 3.6V_{IN}, 3.2V_{OUT} at 150mA)
- Fast Turn-on time when Enabled (50 μ s typ.), 3GPP Compliant
- 10-pin micro SMD Package
- Current Overload Protection
- Thermal Overload Protection

Applications

- Cellular Phones
- Hand-Held Radios
- RF PC Cards
- Battery Powered RF Devices

Typical Application

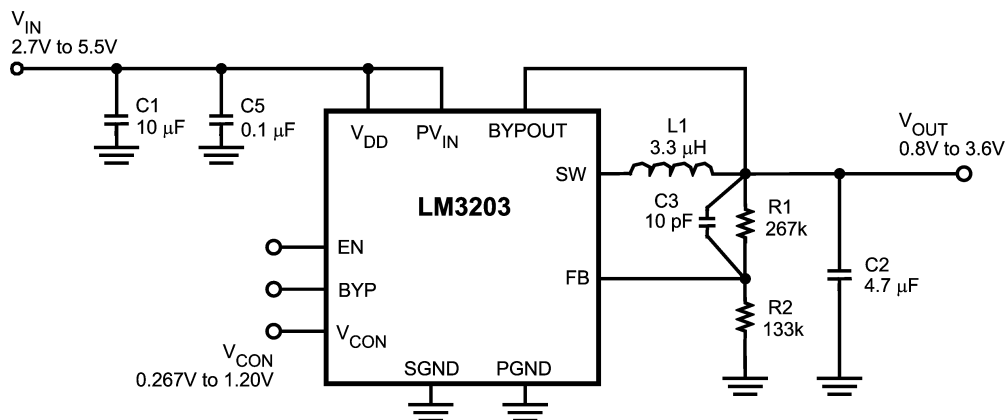

20141601

Connection Diagrams

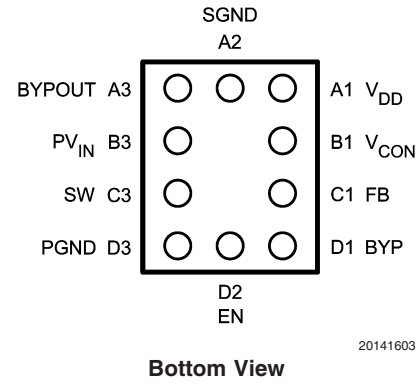
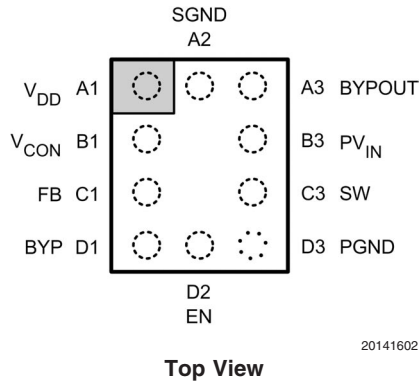

10-Bump Thin Micro SMD Package, Large Bump
See NS Package Number TLP10NHA

Order Information

Order Number	Package Marking (Note)	Supplied As
LM3203TL	XYTT SFYB	250 Units, Tape and Reel
LM3203TLX	XYTT SFYB	3000 Units, Tape and Reel

Note: The package marking "XY" designates the date code. "TT" is a NSC internal code for die traceability.

Pin Description

Pin #	Name	Description
A1	V_{DD}	Analog Supply Input. A 0.1 μF ceramic capacitor is recommended to be placed as close to this pin as possible. (Figure 1)
B1	V_{CON}	Voltage Control Analog input. V_{CON} controls V_{OUT} in PWM mode. (Refer Setting the output voltage under Application information.) Do not leave floating.
C1	FB	Feedback Analog Input. Connect to the external resistor divider. (Figure 1)
D1	BYP	Bypass. Use this digital input to command operation in Bypass mode. Set BYP low for PWM operation.
D2	EN	Enable Input. Set this digital input high after $V_{in} > 2.7\text{V}$ for normal operation. For shutdown, set low.
D3	PGND	Power Ground
C3	SW	Switching Node connection to the internal PFET switch and NFET synchronous rectifier. Connect to an inductor with a saturation current rating that exceeds the maximum Switch Peak Current Limit specification of the LM3203.
B3	PV_{IN}	Power Supply Voltage Input to the internal PFET switch and Bypass FET. (Figure 1)
A3	BYPOUT	Bypass FET Drain. Connect to the output capacitor. (Figure 1) Connect this pin to V_{DD} when Bypass mode is NOT required. Do not leave floating.
A2	SGND	Analog and Control Ground

Absolute Maximum Ratings (Notes 1, 2)

If Military/Aerospace specified devices are required, please contact the National Semiconductor Sales Office/Distributors for availability and specifications.

V_{DD} , PV_{IN} to SGND	-0.2V to +6.0V
PGND to SGND	-0.2V to +0.2V
EN, FB, BYP, V_{CON}	(SGND -0.2V) to (V_{DD} +0.2V) w/6.0V max
SW, BYPOUT	(PGND -0.2V) to (PV_{IN} +0.2V) w/6.0V max
PV_{IN} to V_{DD}	-0.2V to +0.2V
Continuous Power Dissipation (Note 3)	Internally Limited
Junction Temperature (T_{J-MAX})	+150°C
Storage Temperature Range	-65°C to +150°C
Maximum Lead Temperature (Soldering, 10 sec)	+260°C

ESD Rating (Note 4)

Human Body Model

2.0 kV

Operating Ratings (Notes 1, 2)

Input Voltage Range	2.7V to 5.5V
Recommended Load Current	
PWM Mode	0mA to 500mA
Bypass Mode	0mA to 500mA
Junction Temperature (T_J) Range	-30°C to +125°C
Ambient Temperature (T_A) Range (Note 5)	-30°C to +85°C

Thermal Properties

Junction-to-Ambient Thermal Resistance (θ_{JA}), TLP10 Package (Note 6)	100°C/W
---	---------

Electrical Characteristics (Notes 2, 7) Limits in standard typeface are for $T_A = T_J = 25^\circ\text{C}$. Limits in **bold-face** type apply over the full operating ambient temperature range ($-30^\circ\text{C} \leq T_A = T_J \leq +85^\circ\text{C}$). Unless otherwise noted, specifications apply to the LM3203 with: $PV_{IN} = V_{DD} = EN = 3.6\text{V}$, $BYP = 0\text{V}$, $V_{CON} = 0.267\text{V}$.

Symbol	Parameter	Conditions	Min	Typ	Max	Units
V_{IN}	Input Voltage Range (Note 8)	$PV_{IN} = V_{DD} = V_{IN}$	2.7		5.5	V
$V_{FB, MIN}$	Feedback Voltage at Minimum Setting	$V_{CON} = 0.267\text{V}$, $V_{IN} = 3.6\text{V}$	0.250	0.267	0.284	V
$V_{FB, MAX}$	Feedback Voltage at Maximum Setting	$V_{CON} = 1.20\text{V}$, $V_{IN} = 4.2\text{V}$	1.176	1.200	1.224	V
OVP	Over-Voltage Protection Threshold	(Note 9)		100	150	mV
I_{SHDN}	Shutdown Supply Current (Note 10)	$EN = SW = BYPOUT = V_{CON} = FB = 0\text{V}$		0.1	3	μA
I_{Q_PWM}	DC Bias Current into V_{DD}	$V_{CON} = 0.267\text{V}$, $FB = 2\text{V}$, $BYPOUT = 0\text{V}$, No Switching		675	780	μA
I_{Q_BYP}		$BYP = 3.6\text{V}$, $V_{CON} = 0.5\text{V}$, No Load		680	780	μA
$R_{DSON (P)}$	Pin-Pin Resistance for P-FET	$I_{SW} = 500\text{mA}$		320	450	$\text{m}\Omega$
$R_{DSON (N)}$	Pin-Pin Resistance for N-FET	$I_{SW} = -200\text{mA}$		310	450	$\text{m}\Omega$
$R_{DSON (BYP)}$	Pin-Pin Resistance for Bypass FET	$I_{BYPOUT} = 500\text{mA}$		85	120	$\text{m}\Omega$
$I_{LIM-PFET}$	Switch Current Limit	(Note 11)	700	820	940	mA
$I_{LIM-BYP}$	Bypass FET Current Limit	(Note 12)	800	1000	1200	mA
F_{OSC}	Internal Oscillator Frequency		1.7	2	2.2	MHz
V_{IH}	Logic High Input Threshold for EN, BYP		1.20			V
V_{IL}	Logic Low Input Threshold for EN, BYP				0.4	V
I_{PIN}	Pin Pull Down Current for EN, BYP	$EN, BYP = 3.6\text{V}$		5	10	μA

Electrical Characteristics (Notes 2, 7) Limits in standard typeface are for $T_A = T_J = 25^\circ\text{C}$. Limits in **boldface** type apply over the full operating ambient temperature range ($-30^\circ\text{C} \leq T_A = T_J \leq +85^\circ\text{C}$). Unless otherwise noted, specifications apply to the LM3203 with: $V_{IN} = V_{DD} = V_{EN} = 3.6\text{V}$, $V_{BYP} = 0\text{V}$, $V_{CON} = 0.267\text{V}$. (Continued)

Symbol	Parameter	Conditions	Min	Typ	Max	Units
Gain	V_{CON} to V_{OUT} Gain			1		V/V
Z_{CON}	V_{CON} Input Resistance	$V_{CON} = 1.2\text{V}$		1		$\text{M}\Omega$

System Characteristics The following spec table entries are guaranteed by design over ambient temperature range if the component values in the typical application circuit are used. **These parameters are not guaranteed by production testing.**

Symbol	Parameter	Conditions	Min	Typ	Max	Units
$T_{STARTUP}$	Time for V_{OUT} to rise to 3.4V in PWM mode	$V_{IN} = 4.2\text{V}$, $C_{OUT} = 4.7\mu\text{F}$, $R_{LOAD} = 10\Omega$ $L = 3.3\mu\text{H}$ ($I_{SAT} > 0.94\text{A}$) $EN = \text{Low to High}$		50		μs
$T_{RESPONSE}$	Time for V_{OUT} to Rise from 0.8V to 3.6V in PWM Mode	$V_{IN} = 4.2\text{V}$, $C_{OUT} = 4.7\mu\text{F}$, $R_{LOAD} = 10\Omega$ $L = 3.3\mu\text{H}$ ($I_{SAT} > 0.94\text{A}$)		30		μs
C_{CON}	V_{CON} Input Capacitance	$V_{CON} = 1\text{V}$, Test frequency = 100kHz			15	pF
T_{ON_BYP}	Bypass FET Turn On Time In Bypass Mode	$V_{IN} = 3.6\text{V}$, $V_{CON} = 0.267\text{V}$, $C_{OUT} = 4.7\mu\text{F}$, $R_{LOAD} = 10\Omega$ $BYP = \text{Low to High}$			30	μs

Note 1: Absolute Maximum Ratings indicate limits beyond which damage to the component may occur. Operating Ratings are conditions under which operation of the device is guaranteed. Operating Ratings do not imply guaranteed performance limits. For guaranteed performance limits and associated test conditions, see the Electrical Characteristics tables.

Note 2: All voltages are with respect to the potential at the GND pins.

Note 3: Internal thermal shutdown circuitry protects the device from permanent damage. Thermal shutdown engages at $T_J = 150^\circ\text{C}$ (typ.) and disengages at $T_J = 130^\circ\text{C}$ (typ.).

Note 4: The Human body model is a 100pF capacitor discharged through a 1.5k Ω resistor into each pin. (MIL-STD-883 3015.7) . National Semiconductor recommends that all integrated circuits be handled with appropriate precautions.

Note 5: In applications where high power dissipation and/or poor package thermal resistance is present, the maximum ambient temperature may have to be de-rated. Maximum ambient temperature (T_{A-MAX}) is dependent on the maximum operating junction temperature ($T_{J-MAX-OP} = 125^\circ\text{C}$), the maximum power dissipation of the device in the application (P_{D-MAX}), and the junction-to ambient thermal resistance of the part/package in the application (θ_{JA}), as given by the following equation: $T_{A-MAX} = T_{J-MAX-OP} - (\theta_{JA} \times P_{D-MAX})$.

Note 6: Junction-to-ambient thermal resistance (θ_{JA}) is taken from thermal measurements, performed under the conditions and guidelines set forth in the JEDEC standard JESD51-2. A 1" x 1", 4 layer, 1.5oz. Cu board was used for the measurements.

Note 7: Min and Max limits are guaranteed by design, test, or statistical analysis. Typical numbers are not guaranteed, but do represent the most likely norm.

Note 8: The LM3203 is designed for mobile phone applications where turn-on after power-up is controlled by the system controller and where requirements for a small package size overrule increased die size for internal Under Voltage Lock-Out (UVLO) circuitry. Thus, it should be kept in shutdown by holding the EN pin low until the input voltage exceeds 2.7V.

Note 9: Over-Voltage protection (OVP) threshold is the voltage above the nominal V_{OUT} where the OVP comparator turns off the PFET switch while in PWM mode. The OVP threshold will be the value of the threshold at the FB voltage times the resistor divider ratio. In the *Figure 1*, 100mV (typ.) $\times ((267\text{K} + 133\text{K}) \div 133\text{K})$.

Note 10: Shutdown current includes leakage current of PFET and Bypass FET.

Note 11: Electrical Characteristic table reflects open loop data (FB=0V and current drawn from SW pin ramped up until cycle by cycle current limit is activated). Refer to datasheet curves for closed loop data and its variation with regards to supply voltage and temperature. Closed loop current limit is the peak inductor current measured in the application circuit by increasing output current until output voltage drops by 10%.

Note 12: Bypass FET current limit is defined as the load current at which the FB voltage is 1V lower than V_{IN} .

Typical Performance Characteristics (Circuit in Figure 1, $V_{IN} = V_{DD} = EN = 3.6V$, $BYP = 0V$, $T_A = 25^\circ C$, unless otherwise noted)

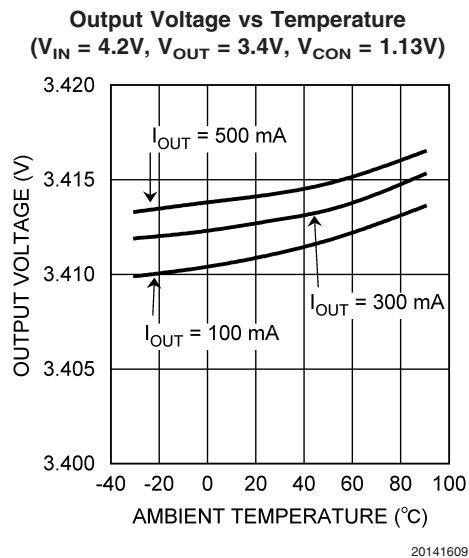
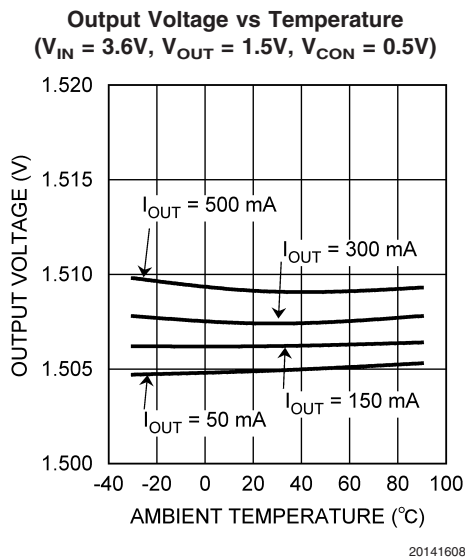
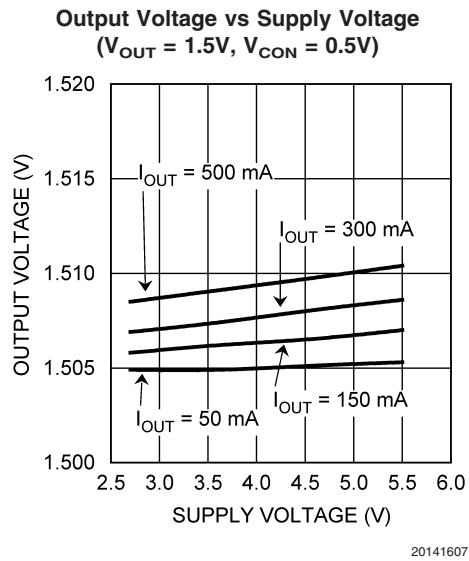
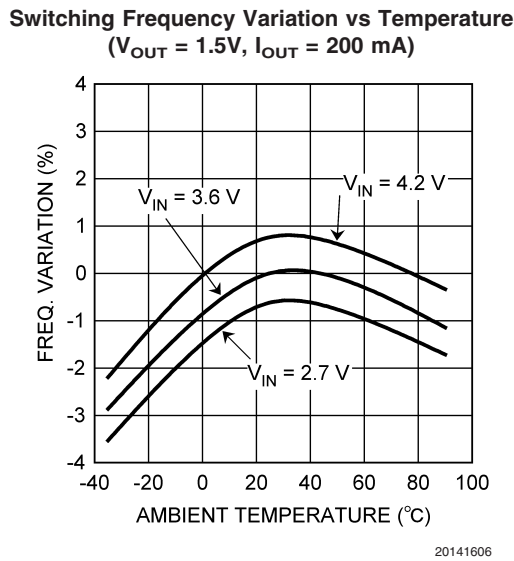
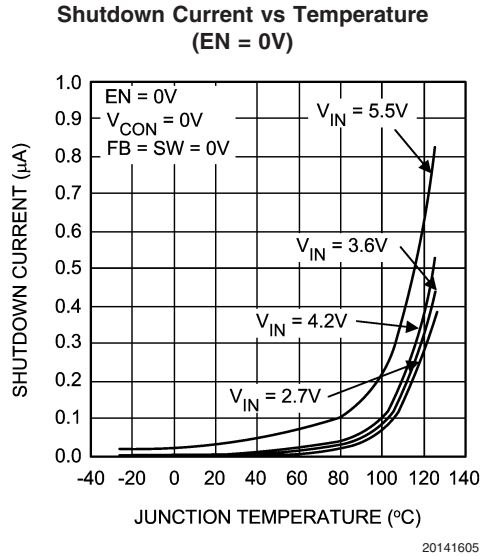
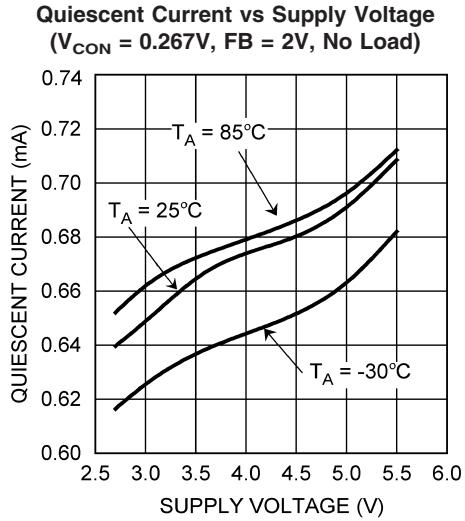

Typical Performance Characteristics (Circuit in *Figure 1*, $PV_{IN} = V_{DD} = EN = 3.6V$, $BYP = 0V$, $T_A = 25^\circ C$, unless otherwise noted) (Continued)

Open/Closed Loop Current Limit vs Temperature (PWM Mode)

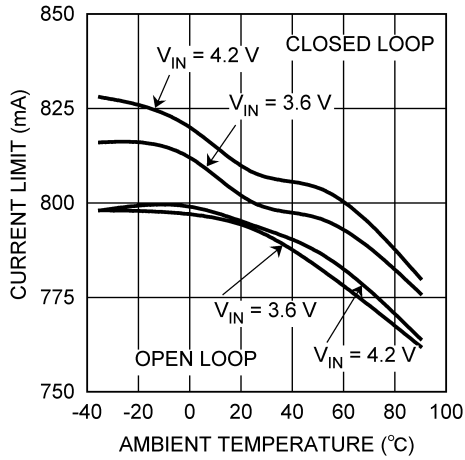

20141612

Output Voltage vs Output Current (BYP Mode, $V_{IN} = 3.6V$)

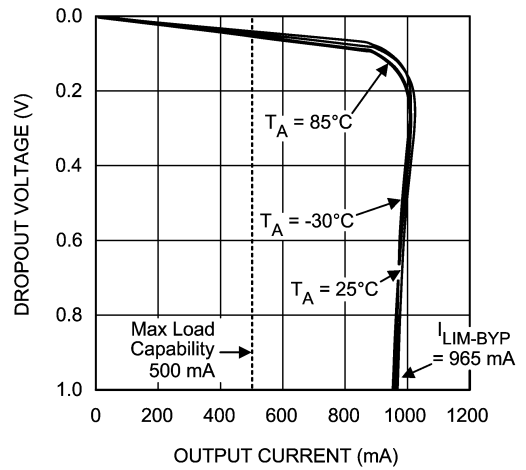

20141613

Low V_{CON} Voltage vs Output Voltage ($R_{LOAD} = 15\Omega$)

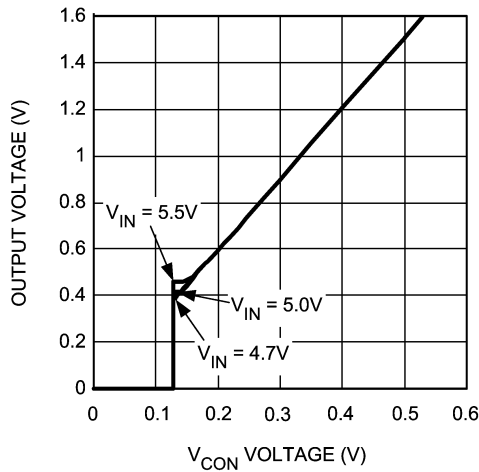

20141615

Efficiency vs Output Voltage ($V_{IN} = 3.9V$)

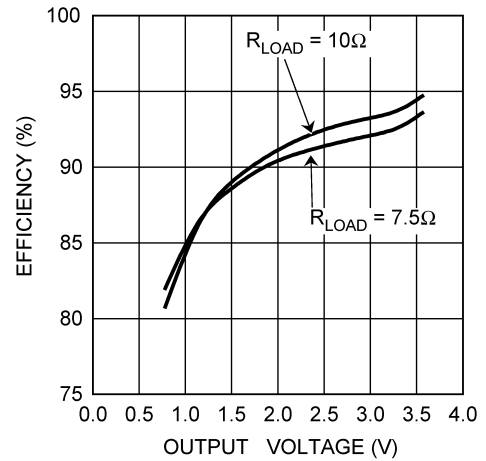

20141617

Typical Performance Characteristics (Circuit in *Figure 1*, $PV_{IN} = V_{DD} = EN = 3.6V$, $BYP = 0V$, $T_A = 25^\circ C$, unless otherwise noted) (Continued)

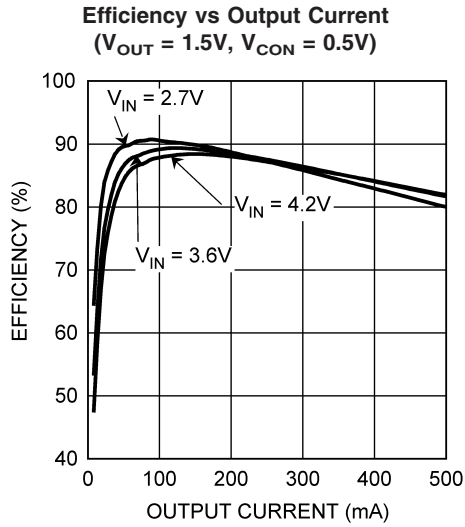

20141618

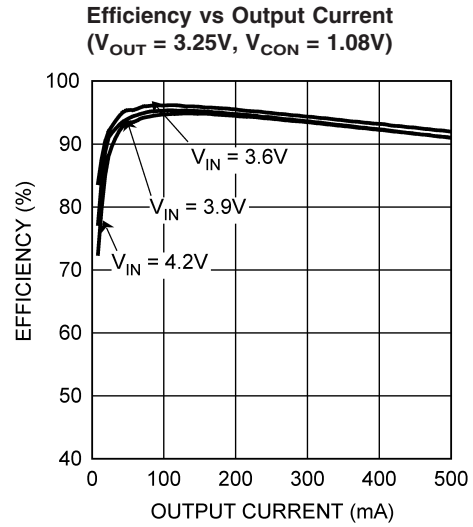

20141619

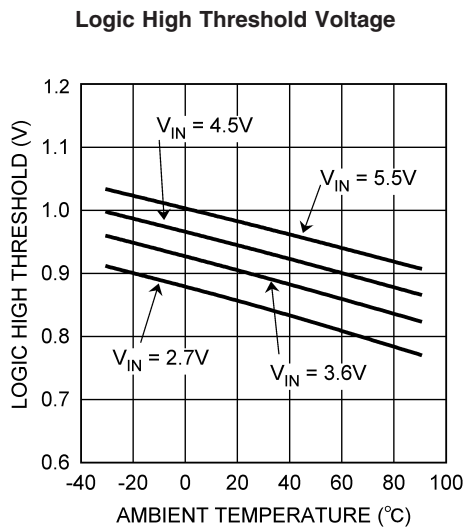

20141642

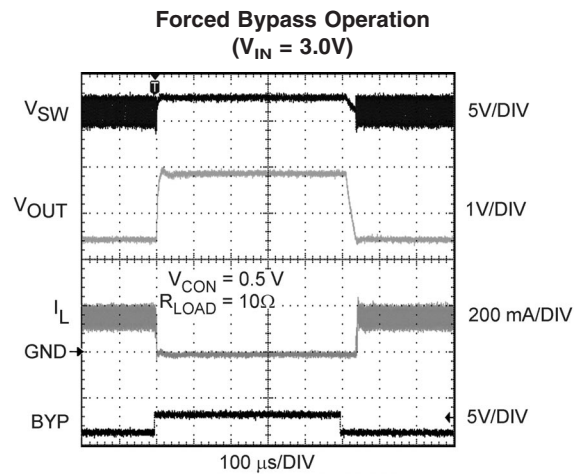

20141625

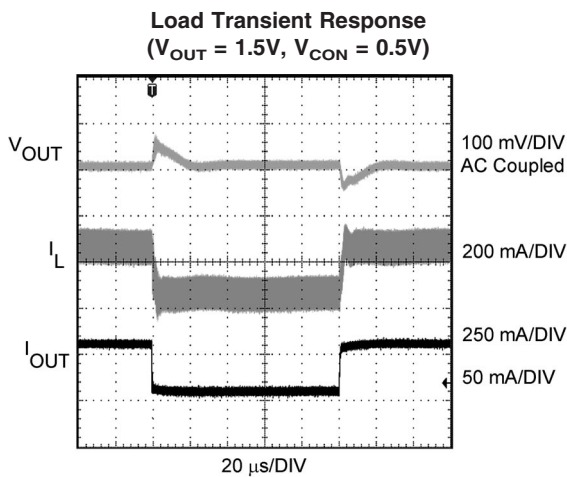

20141620

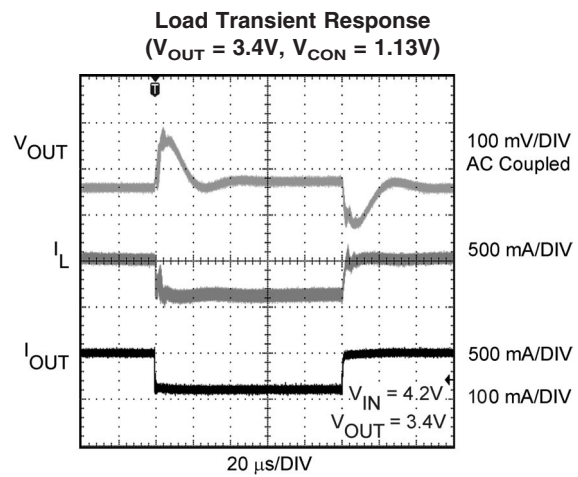

20141621

Typical Performance Characteristics (Circuit in *Figure 1*, $PV_{IN} = V_{DD} = EN = 3.6V$, $BYP = 0V$, $T_A = 25^\circ C$, unless otherwise noted) (Continued)

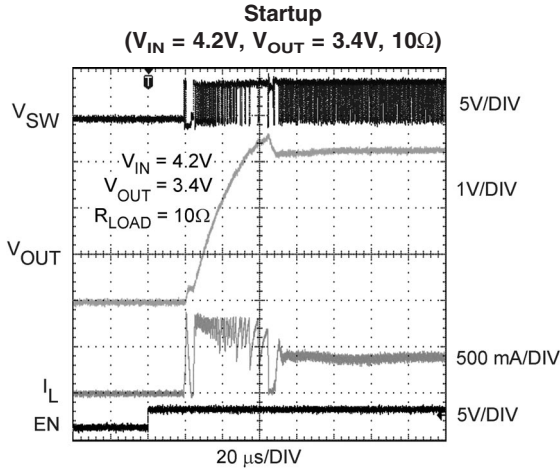

20141622

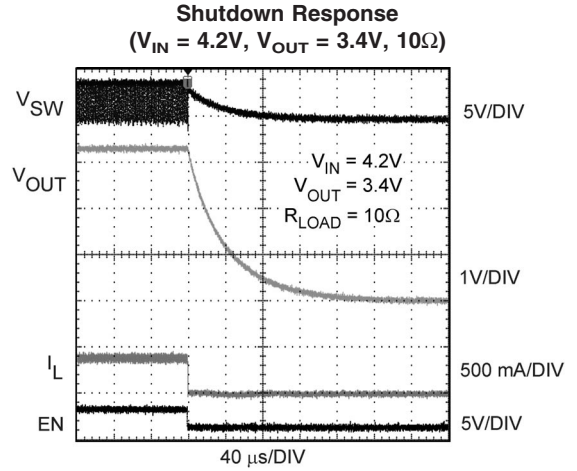

20141623

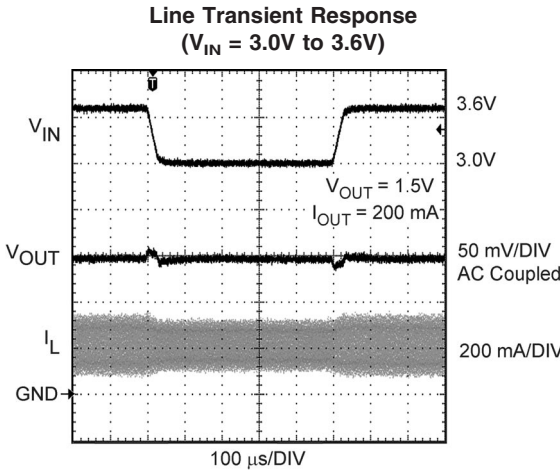

20141626

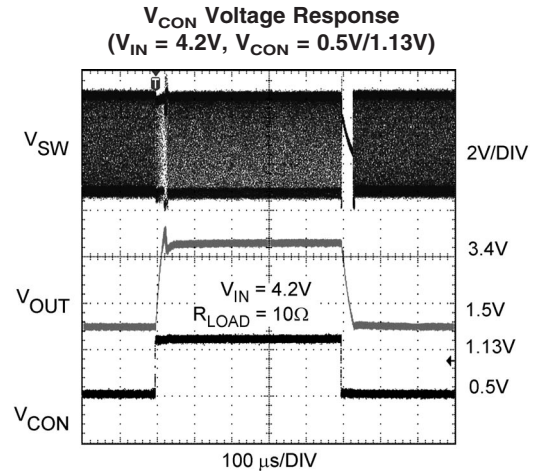

20141627

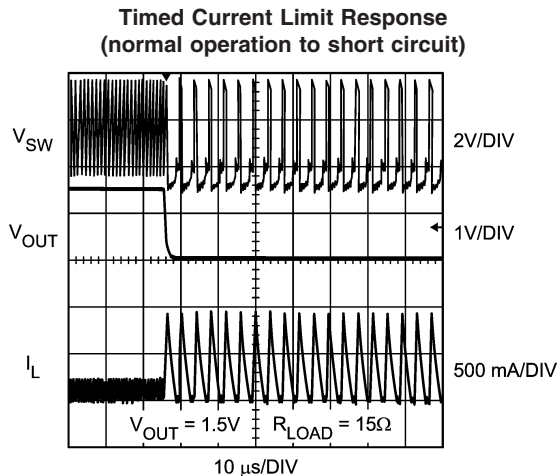

20141628

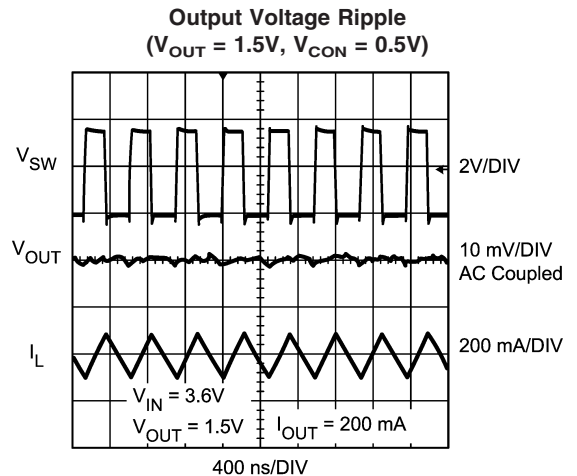

20141629

Typical Performance Characteristics (Circuit in *Figure 1*, $PV_{IN} = V_{DD} = EN = 3.6V$, $BYP = 0V$, $T_A = 25^\circ C$, unless otherwise noted) (Continued)

Output Voltage Ripple
($V_{OUT} = 3.25V$, $V_{CON} = 1.08V$)

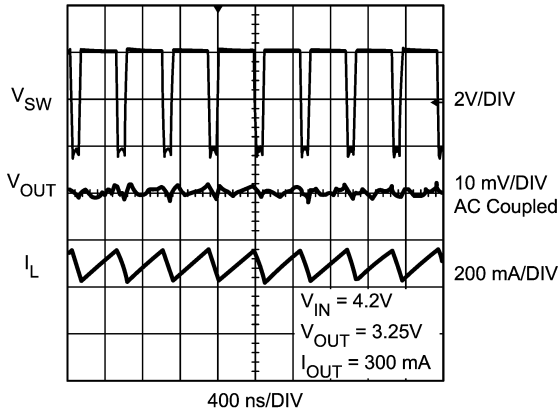

20141630

Output Voltage Ripple in Dropout
($V_{IN} = 3.57V$, $V_{OUT} = 3.25V$, $I_{LOAD} = 200 mA$)

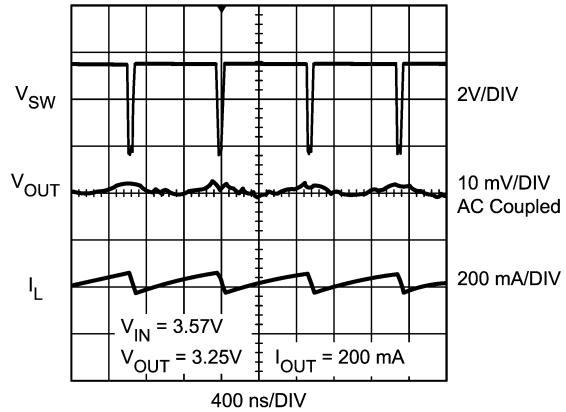

20141631

R_{DS(ON)} vs Temperature (P-FET)

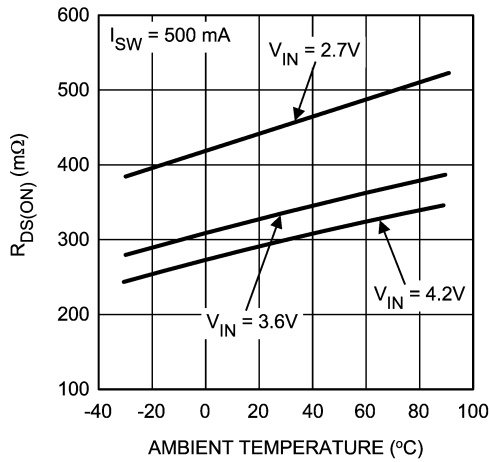

20141632

R_{DS(ON)} vs Temperature (N-FET)

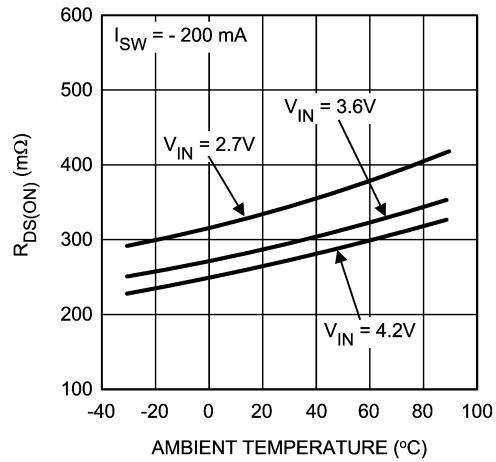

20141633

R_{DS(ON)} vs Temperature (Bypass FET)

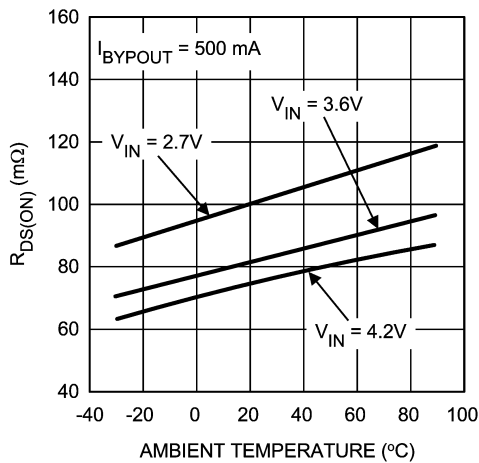

20141634

Dropout Voltage vs Output Current
(R_{DC} : Inductor DC Resistance)

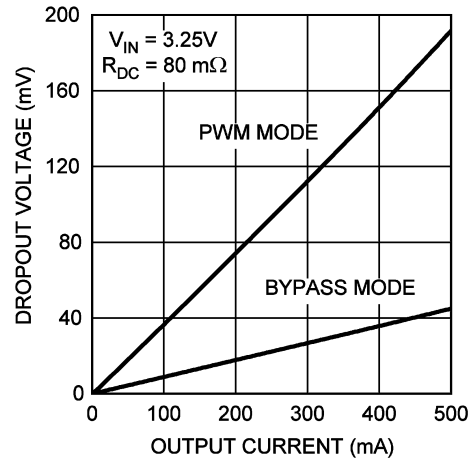

20141641

Block Diagram

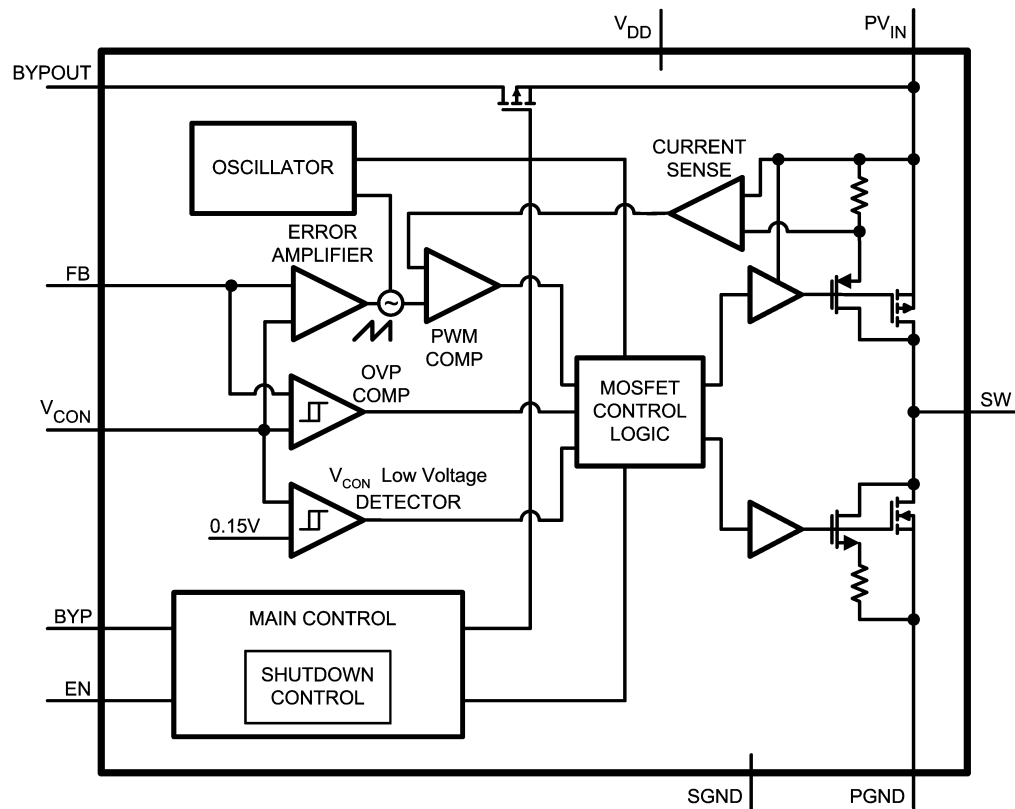

20141635

Operation Description

The LM3203 is a simple, step-down DC-DC converter with a bypass switch, optimized for powering RF power amplifiers (PAs) in mobile phones, portable communicators, and similar battery powered RF devices. It is designed to allow the RF PA to operate at maximum efficiency over a wide range of power levels from a single Li-Ion battery cell. It is based on current-mode buck architecture, with synchronous rectification for high efficiency. It is designed for a maximum load capability of 500mA. Maximum load range may vary from this depending on input voltage, output voltage and the inductor chosen.

The device has all three of the pin-selectable operating modes required for powering RF PAs in mobile phones and other sophisticated portable device with complex power management needs. Fixed-frequency PWM operation offers regulated output at high efficiency while minimizing interference with sensitive IF and data acquisition circuits. Bypass mode turns on an internal FET bypass switch to power the PA directly from the battery. This helps the RF power amplifier maintain its operating power during low battery conditions by reducing the dropout voltage across the LM3203. Shutdown mode turns the device off and reduces battery consumption to 0.1 μ A (typ.).

DC PWM mode output voltage precision is $\pm 2\%$ for 1.2V_{OUT}. Efficiency is typically around 96% for a 150mA load

with 3.2V output, 3.6V input. PWM mode quiescent current is 0.675 mA (typ.). The FB pin voltage is dynamically programmable from 0.267V to 1.2V by adjusting the voltage on the V_{CON}. External divider resistors can change the output voltage range. This ensures longer battery life by being able to change the PA supply voltage dynamically depending on its transmitting power.

Additional features include current overload protection, over voltage protection and thermal shutdown.

The LM3203 is constructed using a chip-scale 10-pin micro SMD package. This package offers the smallest possible size, for space-critical applications such as cell phones, where board area is an important design consideration. Use of a high switching frequency (2MHz typ.) reduces the size of external components. Use of a micro SMD package requires special design considerations for implementation. (See Micro SMD Package Assembly and use in the Applications Information section.) Its fine bump-pitch requires careful board design and precision assembly equipment. Use of this package is best suited for opaque-case applications, where its edges are not subject to high-intensity ambient red or infrared light. Also, the system controller should set EN low during power-up and other low supply voltage conditions. (See Shutdown Mode in the Device Information section.)

Operation Description (Continued)

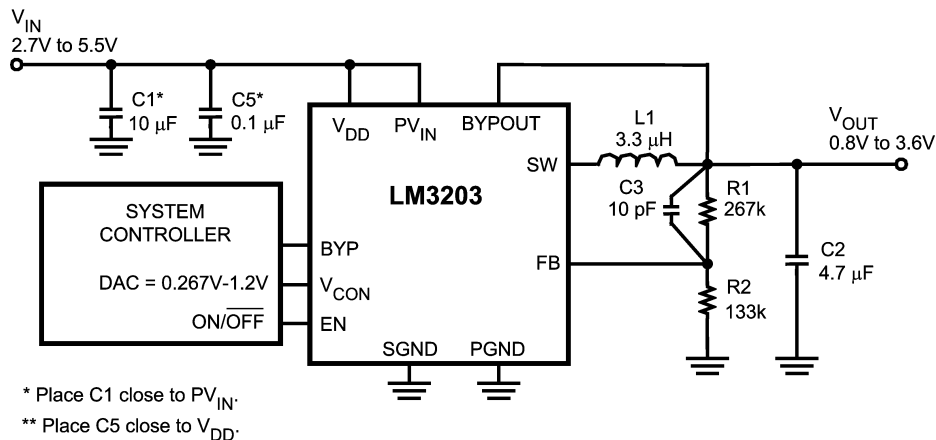

20141636

FIGURE 1. Typical Operating System Circuit where baseband controls the output voltage using a DAC

Circuit Operation

Referring to *Figure 1*, the LM3203 operates as follows. During the first part of each switching cycle, the control block in the LM3203 turns on the internal PFET (P-channel MOSFET) switch. This allows current to flow from the input through the inductor to the output filter capacitor and load. The inductor limits the current to a ramp with a slope of around $(V_{IN} - V_{OUT}) / L$, by storing energy in a magnetic field. During the second part of each cycle, the controller turns the PFET switch off, blocking current flow from the input, and then turns the NFET (N-channel MOSFET) synchronous rectifier on. In response, the inductor's magnetic field collapses, generating a voltage that forces current from ground through the synchronous rectifier to the output filter capacitor and load. As the stored energy is transferred back into the circuit and depleted, the inductor current ramps down with a slope around V_{OUT} / L . The output filter capacitor stores charge when the inductor current is going high, and releases it when inductor current is going low, smoothing the voltage across the load.

The output voltage is regulated by modulating the PFET switch on time to control the average current sent to the load. The effect is identical to sending a duty-cycle modulated rectangular wave formed by the switch and synchronous rectifier at SW to a low-pass filter formed by the inductor and output filter capacitor. The output voltage is equal to the average voltage at the SW pin.

PWM Mode

While in PWM (Pulse Width Modulation) mode, the output voltage is regulated by switching at a constant frequency and then modulating the energy per cycle to control power to the load. Energy per cycle is set by modulating the PFET switch on-time pulse width to control the peak inductor current. This is done by comparing the PFET drain current to a slope-compensated reference current generated by the error amplifier. At the beginning of each cycle, the clock turns on the PFET switch, causing the inductor current to ramp up. When the current sense signal ramps past the error amplifier signal, the PWM comparator turns off the PFET switch and turns on the NFET synchronous rectifier, ending the first part

of the cycle. If an increase in load pulls the output down, the error amplifier output increases, which allows the inductor current to ramp higher before the comparator turns off the PFET. This increases the average current sent to the output and adjusts for the increase in the load. The minimum on-time of PFET in PWM mode is 50ns (typ.).

Bypass Mode

The LM3203 contains an internal PFET switch for bypassing the PWM DC-DC converter during Bypass mode. In Bypass mode, this PFET is turned on to power the PA directly from the battery for maximum RF output power. Bypass mode is more efficient than operating in PWM mode at 100% duty cycle because the resistance of the bypass PFET is less than the series resistance of the PWM PFET and inductor. This translates into higher voltage available on the output in Bypass mode, for a given battery voltage. The part can be placed in bypass mode by sending BYP pin high. It remains in bypass mode until BYP pin goes low.

It is recommended to connect BYPOUT pin directly to the output capacitor with a separate trace and not to the FB pin. Connect the BYPOUT pin to the V_{DD} pin when Bypass mode is not required.

If V_{CON} is less than approx. 0.15V, the Bypass FET is turned off.

Operating Mode Selection Control

The LM3203 is designed for digital control of the operating modes using the BYP pin. Setting the BYP pin high (>1.2V) places the device in Bypass mode. Setting BYP pin low (<0.4V) forces operation in PWM mode.

Bypass and PWM operation overlap during the transition between the two modes. This transition time is approximately 31µs when changing from PWM to Bypass mode, and 15µs when changing from Bypass to PWM mode. This helps prevent under or overshoots during the transition period between PWM and Bypass modes.

Shutdown Mode

Setting the EN digital pin low (<0.4V) places the LM3203 in a 0.1µA (typ.) Shutdown mode. During shutdown, the PFET switch, NFET synchronous rectifier, reference voltage source, control and bias circuitry of the LM3203 are turned off. Setting EN high (>1.2V) enables normal operation.

EN should be set low to turn off the LM3203 during power-up and under voltage conditions when the power supply is less than the 2.7V minimum operating voltage. The LM3203 is designed for compact portable applications, such as mobile phones. In such applications, the system controller determines power supply sequencing and requirements for small package size outweigh the benefit of including UVLO (Under Voltage Lock-Out) circuitry.

Dynamically Adjustable Output Voltage

The LM3203 features dynamically adjustable output voltage. The output can be set by changing the voltage on the analog V_{CON} pin. This feature is useful in PA applications where peak power is needed only when the handset is far away from the base station or when data is being transmitted. In other instances, the transmitting power can be reduced. Hence the supply voltage to the PA can be reduced, promoting longer battery life. See *Setting the Output Voltage* in the *Application Information* section for further details.

Over Voltage Protection

The LM3203 has an over voltage comparator that prevents the output voltage from rising too high, when the device is left in PWM mode under light-load conditions, during output voltage steps, or during startup. When the FB pin voltage rises by 100mV over the V_{CON} voltage, the OVP comparator inhibits PWM operation to skip pulses until the feedback voltage returns to the V_{CON} voltage. During the over voltage protection mode, both the PWM PFET and the NFET synchronous rectifier are off. When the part comes out of the over-voltage protection mode, the NFET synchronous rectifier remains off for approximately 3.5µs to avoid inductor current going negative.

Internal Synchronous Rectification

While in PWM mode, the LM3203 uses an internal NFET as a synchronous rectifier to reduce rectifier forward voltage drop and associated power loss. Synchronous rectification provides a significant improvement in efficiency whenever the output voltage is relatively low compared to the voltage drop across an ordinary rectifier diode.

With medium and heavy loads, the internal NFET synchronous rectifier is turned on during the inductor current down slope in the second part of each cycle. The synchronous rectifier is turned off prior to the next cycle. There is no zero cross detect, which means that the NFET can conduct current in both directions and inductor current is always continuous. The advantage of this method is that the part remains in PWM mode at light loads or no load conditions. The NFET has a current limit. The NFET is designed to conduct through its intrinsic body diode during transient intervals before it turns on, eliminating the need for an external diode.

Current Limiting

A current limit feature allows the LM3203 to protect itself and external components during overload conditions. In PWM

mode, a 940mA (max.) cycle-by-cycle current limit is normally used. If an excessive load pulls the output voltage down to below approximately 0.375V, indicating a possible short to ground, then the device switches to a timed current limit mode. In timed current limit mode, the internal PFET switch is turned off after the current comparator trips, and the beginning of the next cycle is inhibited for 3.5µs to force the instantaneous inductor current to ramp down to a safe value. After the 3.5µs interval, the internal PFET is turned on again. This cycle is repeated until the load is reduced and the output voltage exceeds approximately 0.375V. Therefore, the device may not startup if an excessive load is connected to the output when the device is enabled. The synchronous rectifier is off in the timed current limit mode. Timed current limit prevents the loss of current control seen in some products when the output voltage is pulled low in serious overload conditions. This timed current limit function is disabled if the BYPOUT pin is connected to V_{DD} .

A current limit is also provided for the NFET. This is approximately –500mA. Both the NFET and the PFET are turned off in negative current limit until the PFET is turned on again at the beginning of the next cycle. The negative current limit inhibits buildup of excessive negative inductor current.

In the Bypass mode, the bypass current limit is 1000mA (typ.). The output voltage drops when the bypass current limit kicks in.

Thermal Overload Protection

The LM3203 has a thermal overload protection function to protect the device from short-term misuse and overload conditions. When the junction temperature exceeds around 150°C, the device inhibits operation. Both the PFET and the NFET are turned off in PWM mode, and the Bypass PFET is turned off in Bypass mode. When the temperature drops below 130°C, normal operation resumes. Prolonged operation in thermal overload conditions may damage the device.

Application Information

SETTING THE OUTPUT VOLTAGE

The LM3203 features a pin-controlled variable feedback voltage. It can be programmed for an output voltage from 0.8V to 3.6V by setting the voltage on the V_{CON} pin, as in the formula below (Refer *Figure 1*). In this scheme the output voltage is directly proportional to V_{CON} .

$$V_{OUT} = ((R1 + R2) / R2) \times V_{CON}$$

When V_{CON} is between 0.267V and 1.20V, the output voltage will follow the above equation. For example, the V_{OUT} is proportionally 3 times of V_{CON} when external resistor dividers are used as in *Figure 1*.

If V_{OUT} is over 3.6V, sub-harmonic oscillation may occur because of insufficient slope compensation.

If the target voltage is less than 0.8V, the output voltage may not be regulated due to the required on-time being less than the minimum on-time (50ns). The output voltage can go lower than 0.8V providing a limited V_{IN} range is used. Refer to datasheet curve (Low V_{CON} Voltage vs Output Voltage) for details. This curve is for a typical part and there could be part to part variation for output voltages less than 0.8V over the limited V_{IN} range. In addition, if the V_{CON} voltage is less than approx. 0.15V, the LM3203 output is off, but the internal bias circuits are still active.

Application Information (Continued)

INDUCTOR SELECTION

A 3.3 μ H inductor with saturation current rating over 940mA is recommended for almost all applications. The inductor resistance should be less than 0.3 Ω for better efficiency. *Table 1* lists suggested inductors and suppliers.

TABLE 1. Suggested Inductors and Their Suppliers

Model	Size (WxLxH) [mm]	Vendor
DO3314-332MX	3.3 x 3.3 x 1.4	Coilcraft
NR3015T3R3M	3.0 x 3.0 x 1.5	Taiyo- Yuden

A 2.2 μ H inductor can be used if maximum current in PWM mode is 300mA. For low-cost applications, an unshielded bobbin inductor can be used. For noise-critical applications, a toroidal or shielded-bobbin inductor should be used. A good practice is to layout the board with footprints accommodating both types for design flexibility. This allows substitution of an unshielded inductor, in the event that noise from low-cost bobbin models is unacceptable. Saturation occurs when the magnetic flux density from current through the windings of the inductor exceeds what the inductor's core material can support with a corresponding magnetic field. This can cause poor efficiency, regulation errors or stress to a DC-DC converter like the LM3203.

CAPACITOR SELECTION

The LM3203 is designed to be used with ceramic capacitors. Use a 10 μ F ceramic capacitor for the input and a 4.7 μ F ceramic capacitor for the output. Ceramic capacitors such as X5R, X7R and B are recommended for both filters. These provide an optimal balance between small size, cost, reliability and performance for cell phones and similar applications. *Table 2* lists suggested capacitors and suppliers.

TABLE 2. Suggested Capacitors and Their Suppliers.

4.7 μ F for C_{OUT} and 10 μ F for C_{IN}

Model	Size (EIA)	Vendor
LMK212BJ475MG	2012 (0805)	Taiyo-Yuden
C2012X5R0J475K	2012 (0805)	TDK
C3216X5R1A106K	3216 (1206)	TDK

The DC bias characteristics of the capacitor must be considered when selecting case sizes. If smaller case size such as 1608 (0603) is selected, the dc bias could reduce the cap value by as much as 40%, in addition to the 20% tolerances and 15% temperature coefficients. Request dc bias curves from manufacturer when making selection. The device has been designed to be stable with output capacitance as low as 3 μ F to account for capacitor tolerances. This value includes dc bias reduction, manufacturing tolerances and temp coefficients.

The input filter capacitor supplies AC current drawn by the PFET switch of the LM3203 in the first part of each cycle and reduces the voltage ripple imposed on the input power source. A 0.1 μ F capacitor is also recommended close to V_{DD} pin. The output filter capacitor absorbs the AC inductor current, helps maintain a steady output voltage during transient load changes and reduces output voltage ripple. These capacitors must be selected with sufficient capacitance and

sufficiently low ESR (Equivalent Series Resistance) to perform these functions. The ESR of the filter capacitors is generally a major factor in voltage ripple.

MICRO SMD PACKAGE ASSEMBLY AND USE

Use of the Micro SMD package requires specialized board layout, precision mounting and careful re-flow techniques, as detailed in National Semiconductor Application Note 1112. Refer to the section *Surface Mount Technology (SMD) Assembly Considerations*. For best results in assembly, alignment ordinals on the PC board should be used to facilitate placement of the device. The pad style used with Micro SMD package must be the NSMD (non-solder mask defined) type. This means that the solder-mask opening is larger than the pad size. This prevents a lip that otherwise forms if the solder-mask and pad overlap, from holding the device off the surface of the board and interfering with mounting. See Application Note 1112 for specific instructions how to do this. The 10-Bump package used for the LM3203 has 300 micron solder balls and requires 10.82 mil pads for mounting on the circuit board. The trace to each pad should enter the pad with a 90° entry angle to prevent debris from being caught in deep corners. Initially, the trace to each pad should be 6-7 mil wide, for a section approximately 6 mil long or longer, as a thermal relief. Then each trace should neck up or down to its optimal width. The important criterion is symmetry. This ensures the solder bumps on the LM3203 re-flow evenly and that the device solders level to the board. In particular, special attention must be paid to the pads for bumps B3, C3 and D3. Because PGND and PV_{IN} are typically connected to large copper planes, inadequate thermal relief can result in inadequate re-flow of these bumps.

The Micro SMD package is optimized for the smallest possible size in applications with red or infrared opaque cases. Because the Micro SMD package lacks the plastic encapsulation characteristic of larger devices, it is vulnerable to light. Backside metalization and/or epoxy coating, along with front-side shading by the printed circuit board, reduce this sensitivity. However, the package has exposed die edges. In particular, Micro SMD devices are sensitive to light, in the red and infrared range, shining on the package's exposed die edges.

Do not use or power-up the LM3203 while subjecting it to high intensity red or infrared light; otherwise degraded, unpredictable or erratic operation may result. Examples of light sources with high red or infrared content include the sun and halogen lamps. Place the device in a case opaque to red or infrared light.

BOARD LAYOUT CONSIDERATIONS

PC board layout is an important part of DC-DC converter design. Poor board layout can disrupt the performance of a DC-DC converter and surrounding circuitry by contributing to EMI, ground bounce, and resistive voltage loss in the traces. These can send erroneous signals to the DC-DC converter, resulting in poor regulation or instability. Poor layout can also result in re-flow problems leading to poor solder joints between the Micro SMD package and board pads. Poor solder joints can result in erratic or degraded performance. Good layout for the LM3203 can be implemented by following a few simple design rules.

Application Information (Continued)

1. Place the LM3203 on 10.82 mil pads. As a thermal relief, connect to each pad with a 7 mil wide, approximately 7 mil long traces, and when incrementally increase each trace to its optimal width. The important criterion is symmetry to ensure the solder bumps on the LM3203 re-flow evenly (see *Micro SMD Package Assembly and Use*).
2. Place the LM3203, inductor and filter capacitors close together and make the trace short. The traces between these components carry relatively high switching currents and act as antennas. Following this rule reduces radiated noise. Place the capacitors and inductor close to the LM3203. The input capacitor should be placed right next to the device between PV_{IN} and PGND pin.
3. Arrange the components so that the switching current loops curl in the same direction. During the first half of each cycle, current flows from the input filter capacitor, through the LM3203 and inductor to the output filter capacitor and back through ground, forming a current loop. In the second half of each cycle, current is pulled up from ground, through the LM3203 by the inductor, to the output filter capacitor and then back through ground, forming a second current loop. Routing these loops so the current curls in the same direction, prevents magnetic field reversal between the two half-cycles and reduces radiated noise.
4. Connect the ground pins of the LM3203, and filter capacitors together using generous component side copper fill as a pseudo-ground plane. Then connect this to the ground-plane (if one is used) with several vias. This reduces ground plane noise by preventing the switching currents from circulating through the ground plane. It also reduces ground bounce at the LM3203 by giving it a low impedance ground connection.
5. Use wide traces between the power components and for power connections to the DC-DC converter circuit. This reduces voltage errors caused by resistive losses across the traces.
6. Route noise sensitive traces, such as the voltage feedback trace, away from noisy traces and components. The voltage feedback trace must remain close to the LM3203 circuit and should be routed directly from FB pin to V_{OUT} at the output capacitor. A good approach is to route the feedback trace on another layer and to have a ground plane between the top layer and the layer on which the feedback trace is routed. This reduces EMI radiation on to the DC-DC converter's own voltage feedback trace.
7. It is recommended to connect BYPOUT pin to V_{OUT} at the output capacitor using a separate trace, instead of connecting it directly to the FB pin for better noise immunity.

Physical Dimensions inches (millimeters) unless otherwise noted

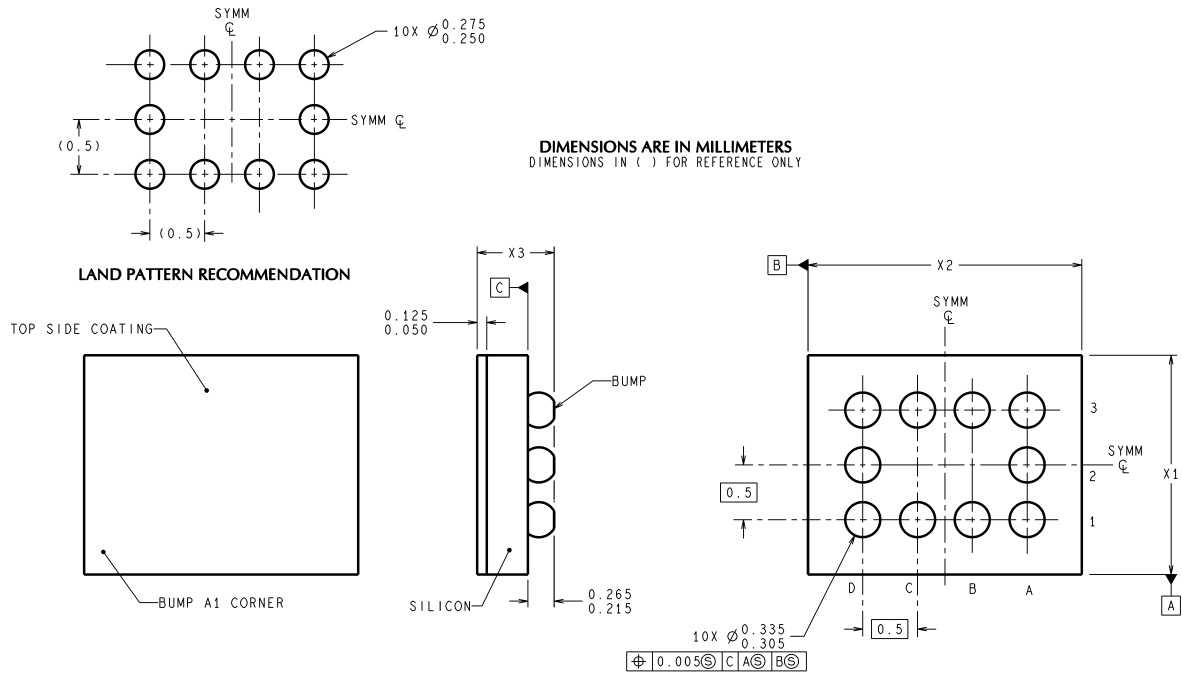

10-Bump Thin Micro SMD, Large Bump
X1 = 1.819mm ± 0.030mm
X2 = 2.174mm ± 0.030mm
X3 = 0.600mm ± 0.075mm
NS Package Number TLP10NHA

National does not assume any responsibility for use of any circuitry described, no circuit patent licenses are implied and National reserves the right at any time without notice to change said circuitry and specifications.
 For the most current product information visit us at www.national.com.

LIFE SUPPORT POLICY

NATIONAL'S PRODUCTS ARE NOT AUTHORIZED FOR USE AS CRITICAL COMPONENTS IN LIFE SUPPORT DEVICES OR SYSTEMS WITHOUT THE EXPRESS WRITTEN APPROVAL OF THE PRESIDENT AND GENERAL COUNSEL OF NATIONAL SEMICONDUCTOR CORPORATION. As used herein:

1. Life support devices or systems are devices or systems which, (a) are intended for surgical implant into the body, or (b) support or sustain life, and whose failure to perform when properly used in accordance with instructions for use provided in the labeling, can be reasonably expected to result in a significant injury to the user.
2. A critical component is any component of a life support device or system whose failure to perform can be reasonably expected to cause the failure of the life support device or system, or to affect its safety or effectiveness.

BANNED SUBSTANCE COMPLIANCE

National Semiconductor manufactures products and uses packing materials that meet the provisions of the Customer Products Stewardship Specification (CSP-9-111C2) and the Banned Substances and Materials of Interest Specification (CSP-9-111S2) and contain no "Banned Substances" as defined in CSP-9-111S2.
 Leadfree products are RoHS compliant.



National Semiconductor
Americas Customer Support Center
 Email: new.feedback@nsc.com
 Tel: 1-800-272-9959

National Semiconductor
Europe Customer Support Center
 Fax: +49 (0) 180-530 85 86
 Email: europe.support@nsc.com
 Deutsch Tel: +49 (0) 69 9508 6208
 English Tel: +44 (0) 870 24 0 2171
 Français Tel: +33 (0) 1 41 91 8790

National Semiconductor
Asia Pacific Customer Support Center
 Email: ap.support@nsc.com

National Semiconductor
Japan Customer Support Center
 Fax: 81-3-5639-7507
 Email: jpn.feedback@nsc.com
 Tel: 81-3-5639-7560

www.national.com