

## PFET Buck Controller for High Power LED Drives

### General Description

The LM3409/09HV are P-channel MosFET (PFET) controllers for step-down (buck) current regulators. They offer wide input voltage range, high-side differential current sense with low adjustable threshold voltage, fast output enable/disable function and a thermally enhanced eMSOP-10 package. These features combine to make the LM3409/09HV ideal for use as constant current sources for driving LEDs where forward currents up to 5A are easily achievable. The LM3409/09HV uses Constant Off-Time (COFT) control to regulate an accurate constant current without the need for external control loop compensation. Analog and PWM dimming are easy to implement and result in a highly linear dimming range with excellent achievable contrast ratios. Programmable UVLO, low-power shutdown, and thermal shutdown complete the feature set.

### Features

- 2Ω, 1A Peak MosFET Gate Drive
- $V_{IN}$  Range: 6V to 42V (LM3409)
- $V_{IN}$  Range: 6V to 75V (LM3409HV)
- Differential, High-side Current Sense
- Cycle-by-Cycle Current Limit
- No Control Loop Compensation Required
- 10,000:1 PWM Dimming Range
- 250:1 Analog Dimming Range
- Supports All-Ceramic Output Capacitors and Capacitorless Outputs
- Low Power Shutdown
- Thermal Shutdown Protection
- Thermally Enhanced eMSOP-10 Package

### Applications

- LED Driver
- Constant Current Source
- Automotive Lighting
- General Illumination
- Industrial Lighting

### Typical Application

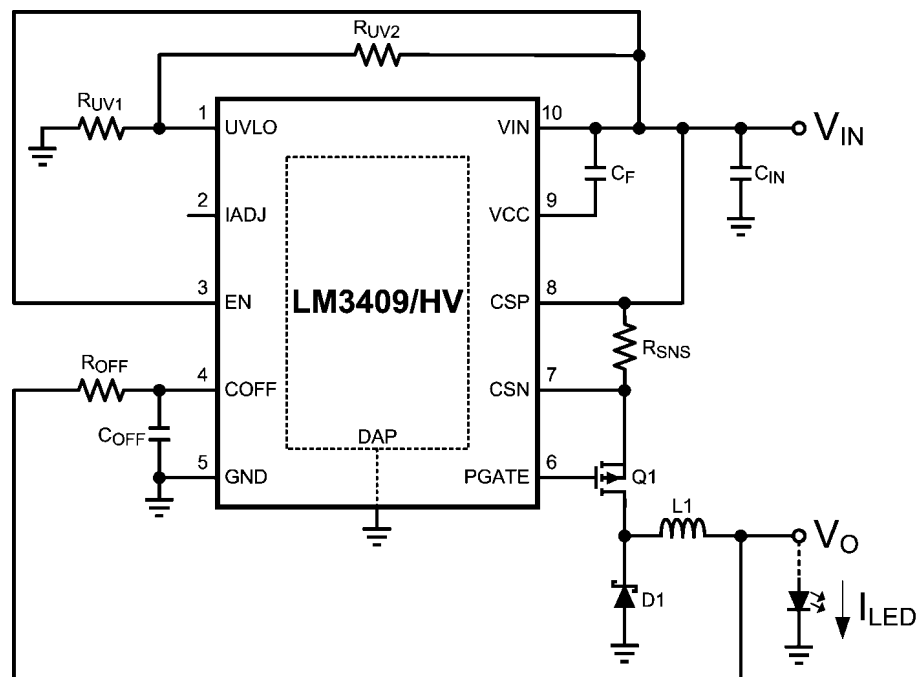

30085601

## Connection Diagram

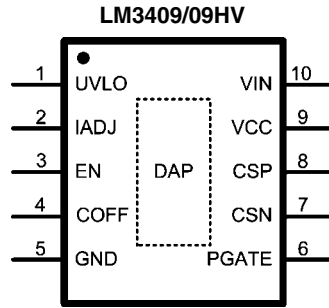

10-Lead Exposed Pad eMSOP Package 30085602

## Ordering Information

Order Number	NSC Package Drawing	Top Marking	Supplied As
LM3409MY	MUC10A	SXFB	1000 Units on tape and reel
LM3409MYX	MUC10A	SXFB	3500 Units on tape and reel
LM3409HVMY	MUC10A	SYHB	1000 Units on tape and reel
LM3409HVMYX	MUC10A	SYHB	3500 Units on tape and reel

## Pin Descriptions

Pin(s)	Name	Description	Application Information
1	UVLO	Input under-voltage lockout	Connect to a resistor divider from $V_{IN}$ and GND. Turn-on threshold is 1.24V and hysteresis for turn-off is provided by a 22 $\mu$ A current source.
2	IADJ	Analog LED current adjust	Apply a voltage between 0 - 1.24V, connect a resistor to GND, or leave open to set the current sense threshold voltage.
3	EN	Logic level enable / PWM dimming	Apply a voltage >1.74V to enable device, a PWM signal to dim, or a voltage <0.5V for low power shutdown.
4	COFF	Off-time programming	Connect a resistor from $V_O$ , and a capacitor from GND to set the off-time.
5	GND	Ground	Connect to the system ground.
6	PGATE	Gate drive	Connect to the gate of the external PFET.
7	CSN	Negative current sense	Connect to the negative side of the sense resistor.
8	CSP	Positive current sense	Connect to the positive side of the sense resistor (also connected to $V_{IN}$ ).
9	VCC	$V_{IN}$ -referenced linear regulator output	Connect at least a 1 $\mu$ F ceramic capacitor to $V_{IN}$ . The regulator provides power for the PFET drive.
10	VIN	Input voltage	Connect to the input voltage.
DAP	DAP	Thermal pad on bottom of IC	Connect to pin 5 (GND). Place 4-6 vias from DAP to bottom layer GND plane.

## Absolute Maximum Ratings

### LM3409/09HV (Note 1)

If Military/Aerospace specified devices are required, please contact the National Semiconductor Sales Office/ Distributors for availability and specifications.

V <sub>IN</sub> , EN, UVLO to GND	-0.3V to 45V (76V LM3409HV)
V <sub>IN</sub> to V <sub>CC</sub> , PGATE	-0.3V to 7V
V <sub>IN</sub> to PGATE	-2.8V for 100ns 9.5V for 100ns
V <sub>IN</sub> to CSP, CSN	-0.3V to 0.3V
COFF to GND	-0.3V to 4V
COFF current	±1 mA continuous
I <sub>ADJ</sub> Current	±5 mA continuous
Junction Temperature	150°C

Storage Temp. Range	-65°C to 125°C
ESD Rating (Note 2)	1kV
Soldering Information	
Lead Temperature (Soldering, 10sec)	260°C
Infrared/Convection Reflow (15sec)	260°C

## Operating Ratings (LM3409/09HV)

(Note 1)

V <sub>IN</sub>	6V to 42V (75V LM3409HV)
Junction Temperature Range	-40°C to +125°C
Thermal Resistance $\theta_{JA}$ (eMSOP-10 Package) (Note 5)	50°C/W

**Electrical Characteristics** V<sub>IN</sub> = 24V unless otherwise indicated. Typicals and limits appearing in plain type apply for T<sub>A</sub> = T<sub>J</sub> = +25°C (Note 3). Limits appearing in **boldface type** apply over full Operating Temperature Range. Datasheet min/max specification limits are guaranteed by design, test, or statistical analysis.

### LM3409/LM3409HV

Symbol	Parameter	Conditions	Min (Note 4)	Typ (Note 3)	Max (Note 4)	Units
<b>PEAK CURRENT COMPARATOR</b>						
V <sub>CST</sub>	V <sub>CSP</sub> - V <sub>CSN</sub> average peak current threshold (Note 6)	V <sub>ADJ</sub> = 1.0V	<b>188</b>	198	<b>208</b>	mV
		V <sub>ADJ</sub> = V <sub>ADJ-OC</sub>	<b>231</b>	246	<b>261</b>	
A <sub>ADJ</sub>	V <sub>ADJ</sub> to V <sub>CSP</sub> - V <sub>CSN</sub> threshold gain	0.1 < V <sub>ADJ</sub> < 1.2V V <sub>ADJ</sub> = V <sub>ADJ-OC</sub>		0.2		V/V
V <sub>ADJ-OC</sub>	I <sub>ADJ</sub> pin open circuit voltage		<b>1.189</b>	1.243	<b>1.297</b>	V
I <sub>ADJ</sub>	I <sub>ADJ</sub> pin current		<b>3.8</b>	5	<b>6.4</b>	µA
t <sub>DEL</sub>	CSN pin falling delay	CSN fall - PGATE rise		38		ns
<b>SYSTEM CURRENTS</b>						
I <sub>IN</sub>	Operating current	Not switching		2		mA
I <sub>SD</sub>	Shutdown hysteresis current	EN = 0V		110		µA
<b>PFET DRIVER</b>						
R <sub>PGATE</sub>	Driver output resistance	Sourcing 50 mA		2		Ω
		Sinking 50 mA		2		
<b>VCC REGULATOR</b>						
V <sub>CC</sub>	V <sub>IN</sub> pin voltage - V <sub>CC</sub> pin voltage	V <sub>IN</sub> > 9V 0 < I <sub>CC</sub> < 20 mA	<b>5.5</b>	6	<b>6.5</b>	V
V <sub>CC-UVLO</sub>	V <sub>CC</sub> under voltage lockout threshold	V <sub>CC</sub> increasing		3.73		V
V <sub>CC-HYS</sub>	V <sub>CC</sub> UVLO hysteresis	V <sub>CC</sub> decreasing		283		mV
I <sub>CC-LIM</sub>	V <sub>CC</sub> regulator current limit		<b>30</b>	45		mA
<b>OFF-TIMER AND ON-TIMER</b>						
V <sub>OFT</sub>	Off-time threshold		<b>1.122</b>	1.243	<b>1.364</b>	V
t <sub>D-OFF</sub>	COFF threshold to PGATE falling delay			25		ns
t <sub>ON-MIN</sub>	Minimum on-time			115	<b>211</b>	ns
t <sub>OFF-MAX</sub>	Maximum off-time			300		µs
<b>UNDER VOLTAGE LOCKOUT</b>						
I <sub>UVLO</sub>	UVLO pin current	V <sub>UVLO</sub> = 1V		10		nA

Symbol	Parameter	Conditions	Min (Note 4)	Typ (Note 3)	Max (Note 4)	Units
$V_{UVLO-R}$	Rising UVLO threshold		1.175	1.243	1.311	V
$I_{UVLO-HYS}$	UVLO hysteresis current			22		$\mu$ A
<b>ENABLE</b>						
$I_{EN}$	EN pin current			10		nA
$V_{EN-TH}$	EN pin threshold	$V_{EN}$ rising			1.74	V
		$V_{EN}$ falling	.5			
$V_{EN-HYS}$	EN pin hysteresis			420		mV
$t_{EN-R}$	EN pin rising delay	EN rise - PGATE fall		42		ns
$t_{EN-F}$	EN pin falling delay	EN fall - PGATE rise		21		ns
<b>THERMAL RESISTANCE</b>						
$\theta_{JA}$	Junction to Ambient	eMSOP-10 Package (Note 5)		50		$^{\circ}$ C/W

**Note 1:** Absolute Maximum Ratings indicate limits beyond which damage to the device may occur, including inoperability and degradation of device reliability and/or performance. Functional operation of the device and/or non-degradation at the Absolute Maximum Ratings or other conditions beyond those indicated in the Operating Ratings is not implied. The recommended Operating Ratings indicate conditions at which the device is functional and the device should not be operated beyond such conditions.

**Note 2:** The human body model is a 100 pF capacitor discharged through a 1.5 k $\Omega$  resistor into each pin.

**Note 3:** Typical values represent most likely parametric norms at the conditions specified and are not guaranteed.

**Note 4:** Min and Max limits are 100% production tested at 25 $^{\circ}$ C. Limits over the operating temperature range are guaranteed through correlation using Statistical Quality Control (SQC) methods. Limits are used to calculate National's Average Outgoing Quality Level (AOQL).

**Note 5:**  $\theta_{JA}$  of 50 $^{\circ}$ C/W with DAP soldered to a minimum of 2 square inches of 1oz. copper on the top or bottom PCB layer. Actual value will be different depending upon the application environment.

**Note 6:** The current sense threshold limits are calculated by averaging the results from the two polarities of the high-side differential amplifier.

**Note 7:** The measurements were made using the Bill of Materials from Design #3.

**Note 8:** The measurements were made using the Bill of Materials from Design #3 except the LM3409 was substituted for the LM3409HV.

**Note 9:** The waveforms were acquired using the standard evaluation board from AN-1953.

## Typical Performance Characteristics

$T_A = +25^\circ\text{C}$ ,  $V_{IN} = 24\text{V}$ , and characteristics are identical for LM3409 and LM3409HV unless otherwise specified.

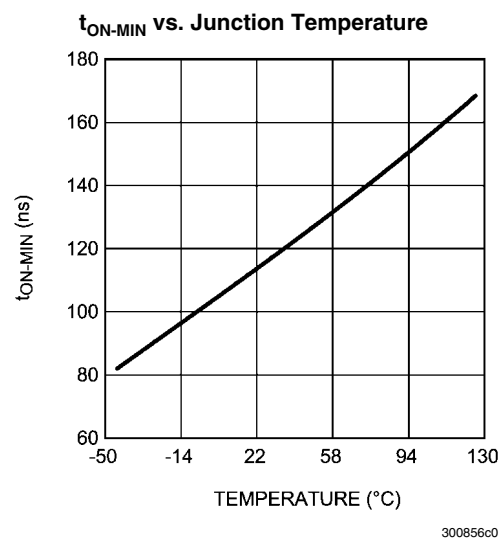
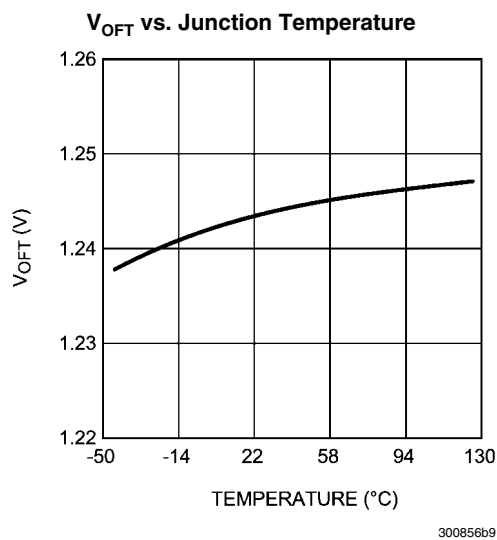
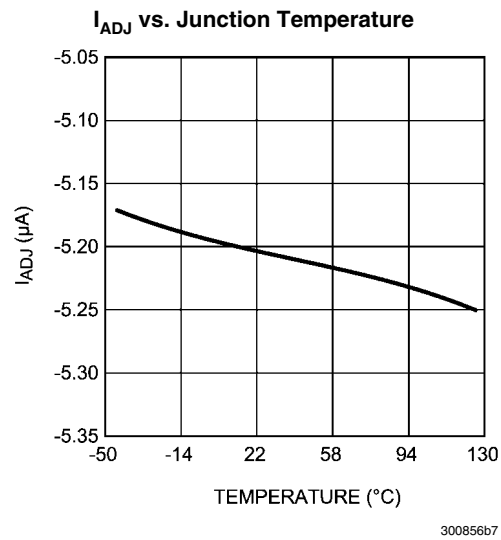
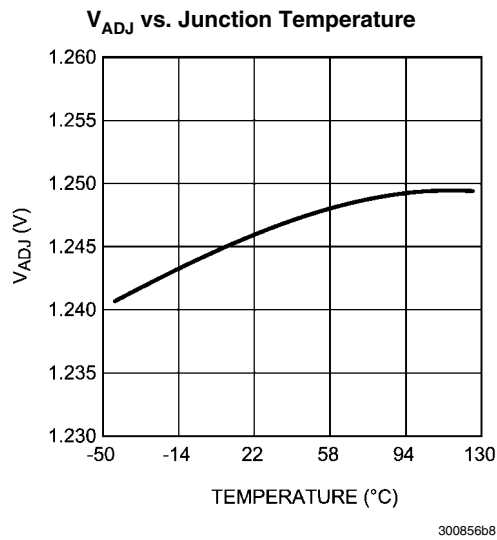
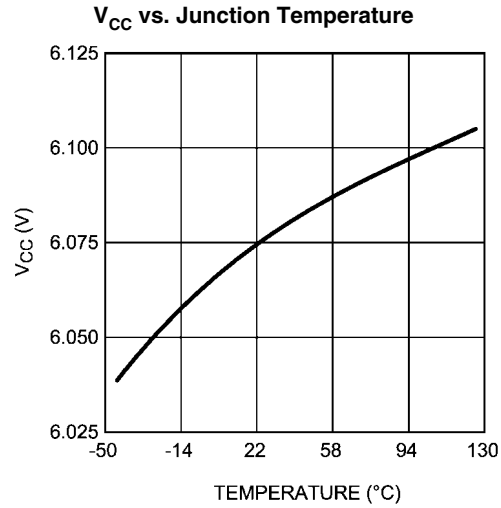
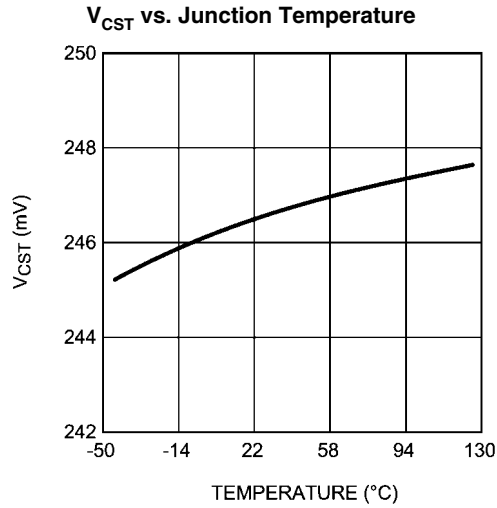

**LM3409 Efficiency vs. Input Voltage**  
 $V_O = 17V$  (5 LEDs);  $I_{LED} = 2A$  (Note 8)

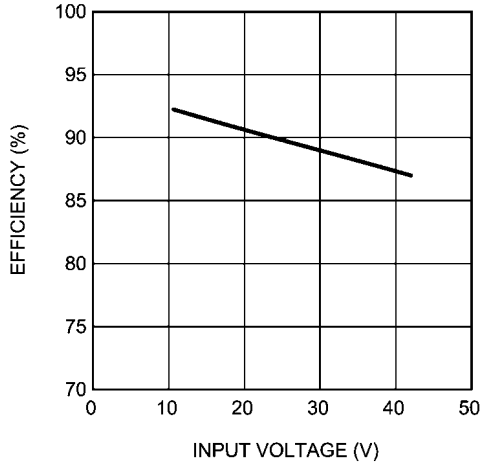

300856f0

**LM3409HV Efficiency vs. Input Voltage**  
 $V_O = 17V$  (5 LEDs);  $I_{LED} = 2A$  (Note 7)

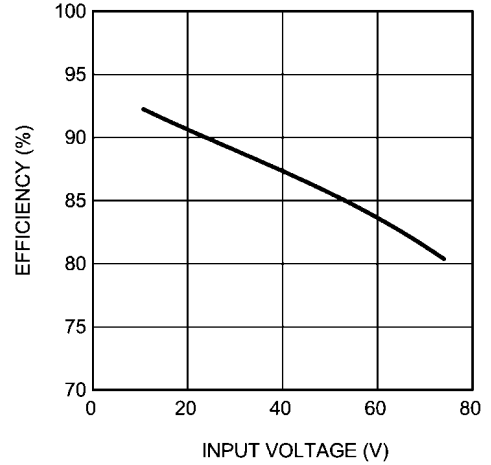

300856b3

**LM3409 LED Current vs. Input Voltage**  
 $V_O = 17V$  (5 LEDs) (Note 8)

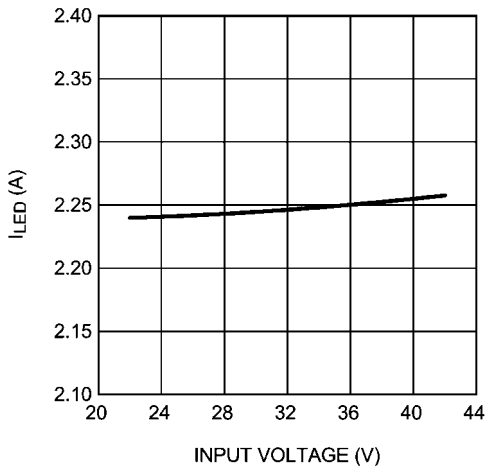

300856f1

**LM3409HV LED Current vs. Input Voltage**  
 $V_O = 17V$  (5 LEDs) (Note 7)

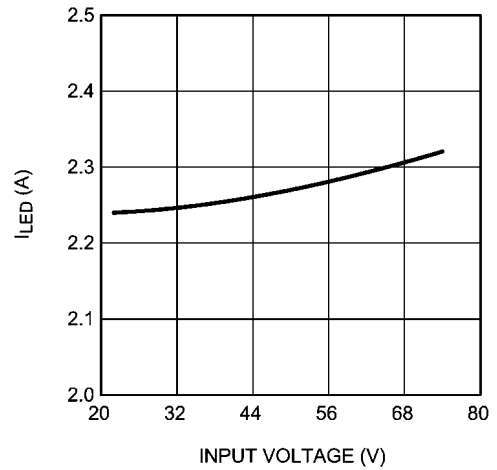

300856b4

**Normalized Switching Frequency vs. Input Voltage**

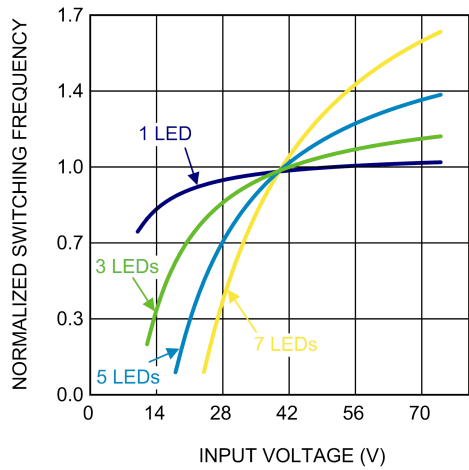

300856c1

**Amplitude Dimming Using IADJ Pin**  
 $V_O = 17V$  (5 LEDs);  $V_{IN} = 24V$

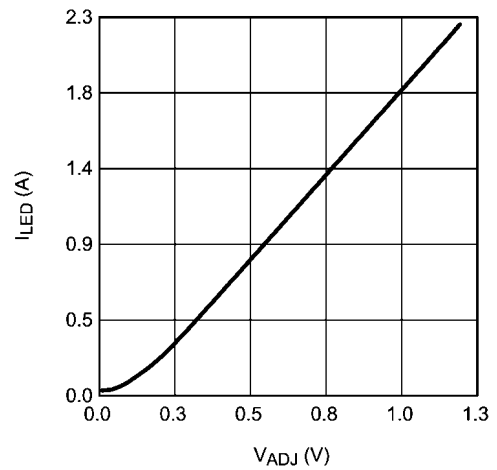

300856b2

**Internal EN Pin PWM Dimming**  
 $V_O = 17V$  (5 LEDs);  $V_{IN} = 24V$

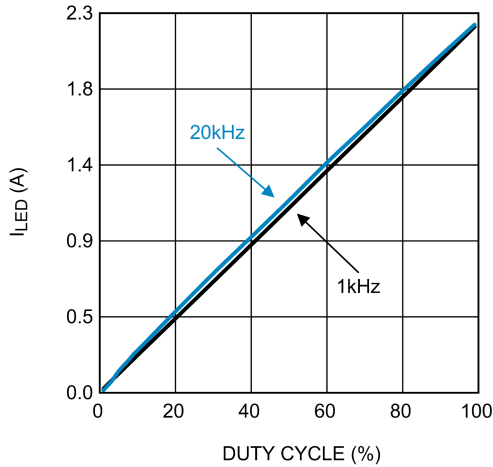

300856b0

**External Parallel FET PWM Dimming**  
 $V_O = 17V$  (5 LEDs);  $V_{IN} = 24V$

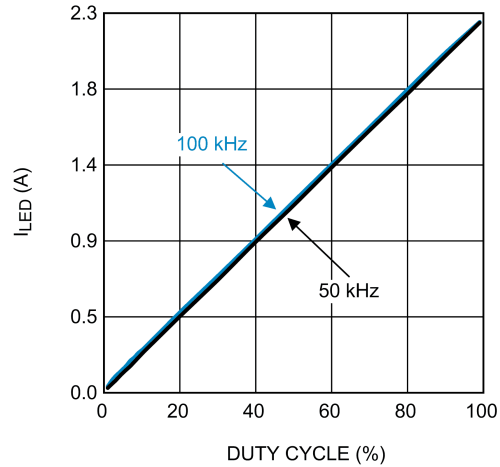

300856b1

**20kHz 50% EN pin PWM dimming**  
 $V_O = 42V$  (12 LEDs);  $V_{IN} = 48V$  (Note 9)

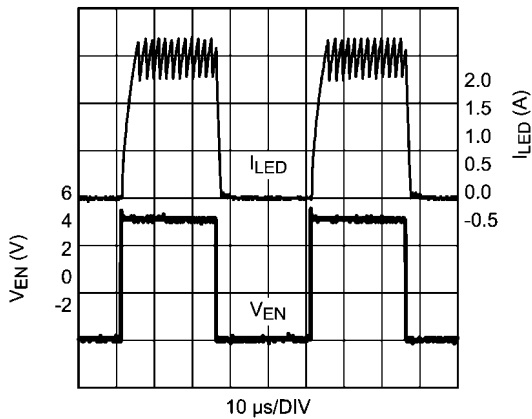

300856f5

**100kHz 50% External FET PWM dimming**  
 $V_O = 42V$  (12 LEDs);  $V_{IN} = 48V$  (Note 9)

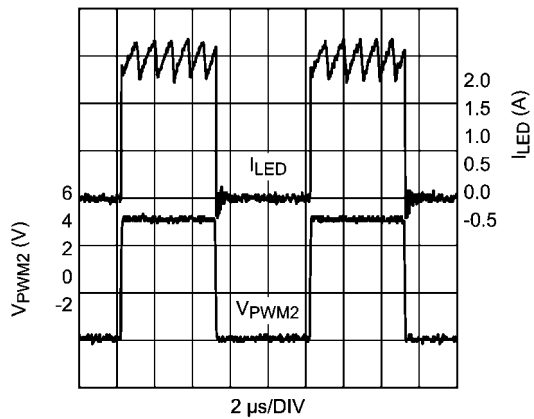

300856f6

**20kHz 50% EN pin PWM dimming (rising edge)**  
 $V_O = 42V$  (12 LEDs);  $V_{IN} = 48V$  (Note 9)

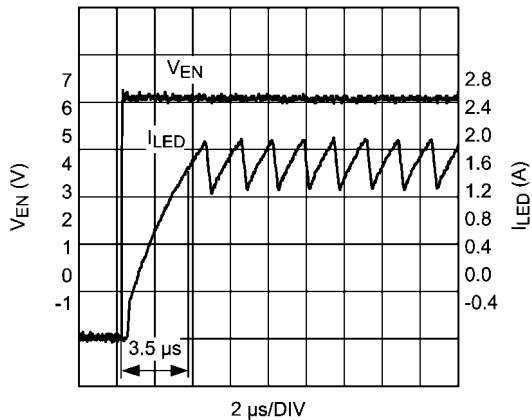

300856f7

**100kHz 50% External FET PWM dimming (rising edge)**  
 $V_O = 42V$  (12 LEDs);  $V_{IN} = 48V$  (Note 9)

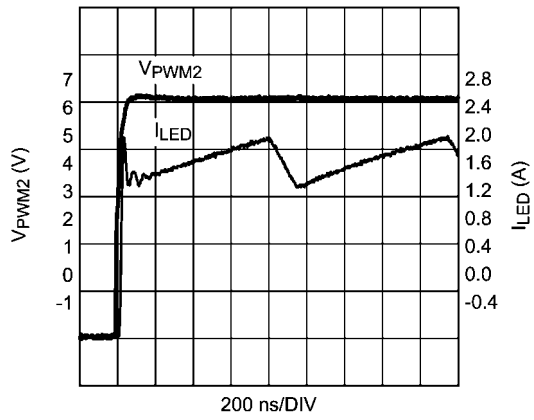

300856f8

## Block Diagram

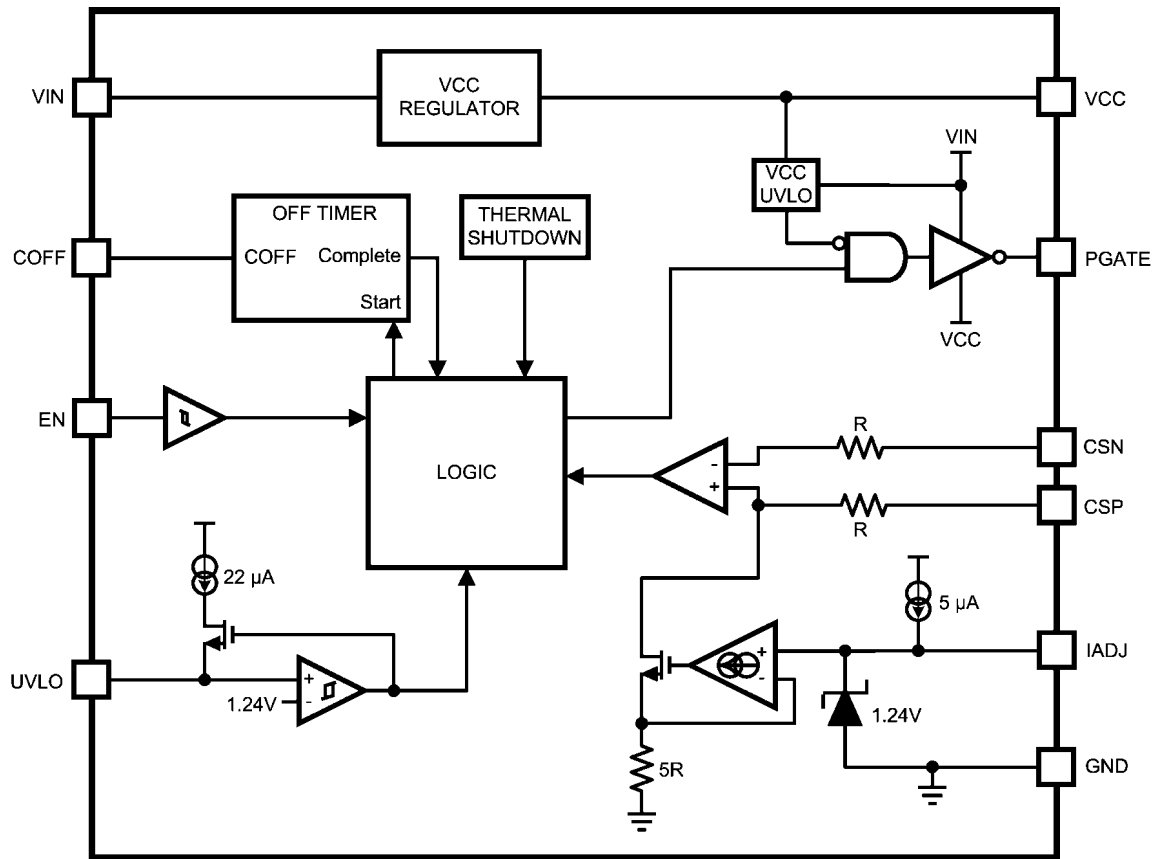

30085603

## Theory of Operation

The LM3409/09HV are P-channel MosFET (PFET) controllers for step-down (buck) current regulators which are ideal for driving LED loads. They have wide input voltage range allowing for regulation of a variety of LED loads. The high-side differential current sense, with low adjustable threshold voltage, provides an excellent method for regulating output current while maintaining high system efficiency. The LM3409/09HV uses a Controlled Off-Time (COFT) architecture that allows the converter to be operated in both continuous conduction mode (CCM) and discontinuous conduction mode (DCM) with no external control loop compensation, while providing an inherent cycle-by-cycle current limit. The adjustable current sense threshold provides the capability to amplitude (analog) dim the LED current over the full range and the fast output enable/disable function allows for high frequency PWM dimming using no external components. When designing, the maximum attainable LED current is not internally limited because the LM3409/09HV is a controller. Instead it is a function of the system operating point, component choices, and switching frequency allowing the LM3409/09HV to easily provide constant currents up to 5A. This simple controller contains all the features necessary to implement a high efficiency versatile LED driver.

## BUCK CURRENT REGULATORS

The buck regulator is unique among non-isolated topologies due to the direct connection of the inductor to the load during the entire switching cycle. An inductor will control the rate of change of current that flows through it, therefore a direct connection to the load is excellent for current regulation. A buck current regulator, using the LM3409/09HV, is shown in the *Typical Application* section on the first page of this datasheet. During the time that the PFET (Q1) is turned on ( $t_{ON}$ ), the input voltage charges up the inductor (L1). When Q1 is turned off ( $t_{OFF}$ ), the re-circulating diode (D1) becomes forward biased and L1 discharges. During both intervals, the current is supplied to the load keeping the LEDs forward biased. *Figure 1* shows the inductor current ( $i_L(t)$ ) waveform for a buck converter operating in CCM.

The average inductor current ( $I_L$ ) is equal to the average output LED current ( $I_{LED}$ ), therefore if  $I_L$  is tightly controlled,  $I_{LED}$  will be well regulated. As the system changes input voltage or output voltage, duty cycle (D) is varied to regulate  $I_L$  and ultimately  $I_{LED}$ . For any buck regulator, D is simply the conversion ratio divided by the efficiency ( $\eta$ ):

$$D = \frac{V_o}{\eta \times V_{IN}}$$



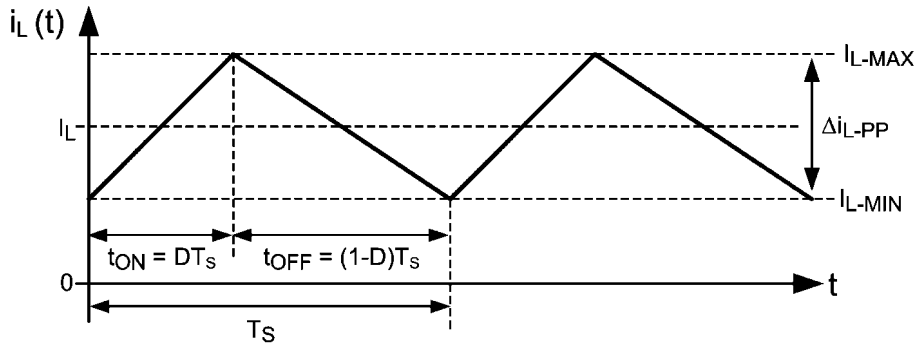

30085604

FIGURE 1. Ideal CCM Buck Converter Inductor Current  $i_L(t)$ 

### CONTROLLED OFF-TIME (COFT) ARCHITECTURE

The COFT architecture is used by the LM3409/09HV to control  $I_{LED}$ . It is a combination of peak current detection and a one-shot off-timer that varies with output voltage.  $D$  is indirectly controlled by changes in both  $t_{OFF}$  and  $t_{ON}$ , which vary depending on the operating point. This creates a variable switching frequency over the entire operating range. This type of hysteretic control eliminates the need for control loop compensation necessary in many switching regulators, simplifying the design process and providing fast transient response.

### Adjustable Peak Current Control

At the beginning of a switching period, PFET Q1 is turned on and inductor current increases. Once peak current is detected, Q1 is turned off, the diode D1 forward biases, and inductor current decreases. *Figure 2* shows how peak current detection is accomplished using the differential voltage signal created as current flows through the current setting resistor ( $R_{SNS}$ ). The voltage across  $R_{SNS}$  ( $V_{SNS}$ ) is compared to the adjustable current sense threshold ( $V_{CST}$ ) and Q1 is turned off when  $V_{SNS}$  exceeds  $V_{CST}$ , providing that  $t_{ON}$  is greater than the minimum possible  $t_{ON}$  (typically 115ns).

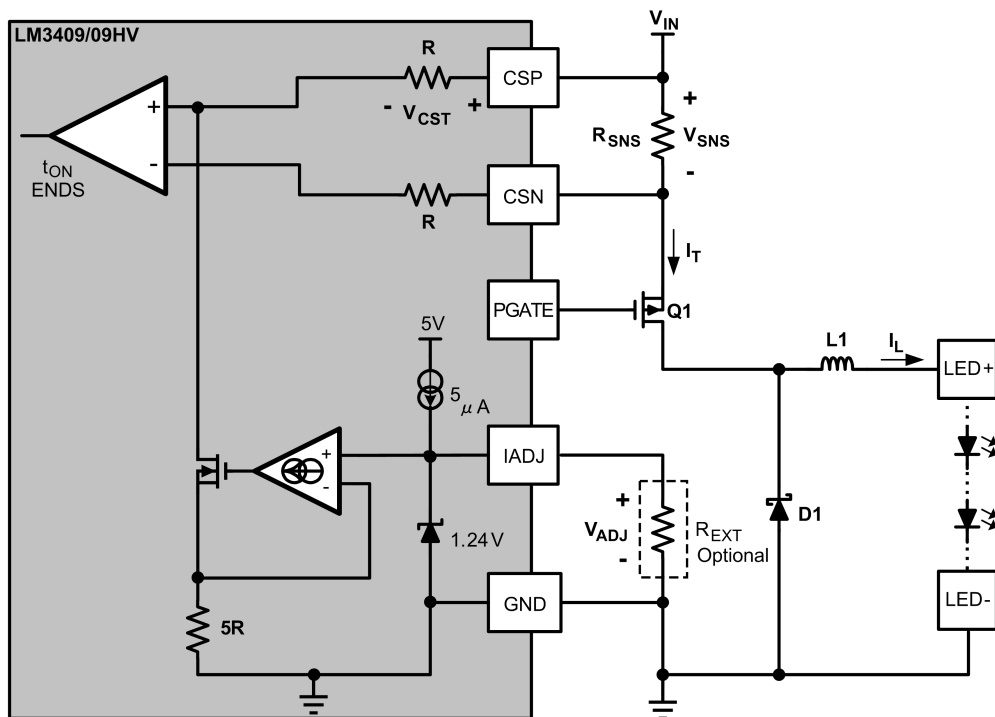

30085605

FIGURE 2. Peak Current Control Circuit

There are three different methods to set the current sense threshold ( $V_{CST}$ ) using the multi-function IADJ pin:

1. IADJ pin left open:  $5\mu\text{A}$  internal current source biases the Zener diode and clamps the IADJ pin voltage ( $V_{ADJ}$ ) at 1.24V causing the maximum threshold voltage:

$$V_{CST} = \frac{V_{ADJ}}{5 \times R} \times R = \frac{V_{ADJ}}{5} = \frac{1.24\text{V}}{5} = 248 \text{ mV}$$

2. External voltage ( $V_{ADJ}$ ) of 0V to 1.24V: Apply to the IADJ pin to adjust  $V_{CST}$  from 0V to 248mV. If the  $V_{ADJ}$  voltage is adjustable, analog dimming can be achieved.
3. External resistor ( $R_{EXT}$ ) placed from IADJ pin to ground:  $5\mu\text{A}$  current source sets the  $V_{ADJ}$  voltage and corresponding threshold voltage:

$$V_{CST} = \frac{V_{ADJ}}{5} = \frac{5\mu\text{A} \times R_{EXT}}{5} = 1\mu\text{A} \times R_{EXT}$$

**Controlled Off-Time**

Once Q1 is turned off, it remains off for a constant time ( $t_{OFF}$ ) which is preset by an external resistor ( $R_{OFF}$ ), an external capacitor ( $C_{OFF}$ ), and the output voltage ( $V_O$ ) as shown in Figure 3. Since  $I_{LED}$  is tightly regulated,  $V_O$  will remain nearly constant over widely varying input voltage and temperature yielding a nearly constant  $t_{OFF}$ .

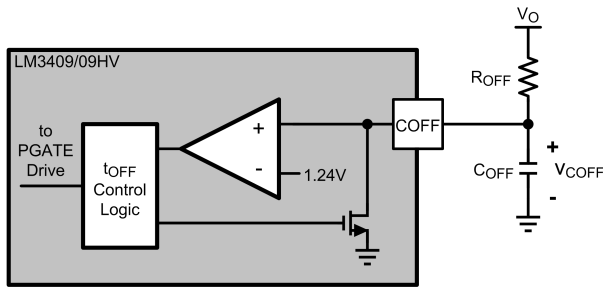
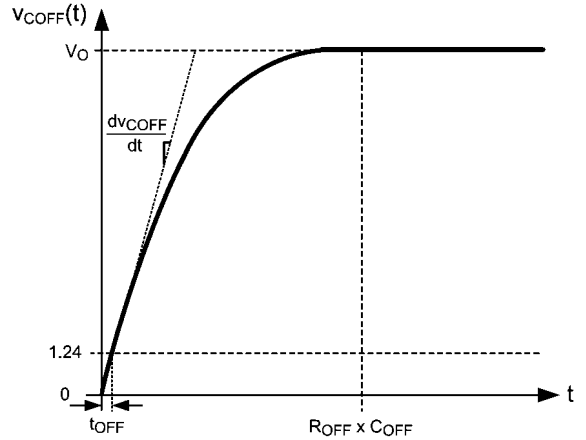

**FIGURE 3. Off-Time Control Circuit**

At the start of  $t_{OFF}$ , the voltage across  $C_{OFF}$  ( $v_{COFF}(t)$ ) is zero and the capacitor begins charging according to the time constant provided by  $R_{OFF}$  and  $C_{OFF}$ . When  $v_{COFF}(t)$  reaches the off-time threshold ( $V_{OFT} = 1.24\text{V}$ ), then the off-time is terminated and  $v_{COFF}(t)$  is reset to zero.  $t_{OFF}$  is calculated as follows:

$$t_{OFF} = -R_{OFF} \times (C_{OFF} + 20 \text{ pF}) \times \ln \left( 1 - \frac{1.24\text{V}}{V_O} \right)$$

In reality, there is typically 20 pF parasitic capacitance at the off-timer pin in parallel with  $C_{OFF}$ , which is accounted for in the calculation of  $t_{OFF}$ . Also, it should be noted that the  $t_{OFF}$  equation has a preceding negative sign because the result of the logarithm should be negative for a properly designed circuit. The resulting  $t_{OFF}$  is a positive value as long as  $V_O > 1.24\text{V}$ . If  $V_O < 1.24\text{V}$ , the off-timer cannot reach  $V_{OFT}$  and an internally limited maximum off-time (typically 300 $\mu\text{s}$ ) will occur.



**FIGURE 4. Exponential Charging Function  $v_{COFF}(t)$**

Although the  $t_{OFF}$  equation is non-linear,  $t_{OFF}$  is actually very linear in most applications. Ignoring the 20pF parasitic capacitance at the COFF pin,  $v_{COFF}(t)$  is plotted in Figure 4. The time derivative of  $v_{COFF}(t)$  can be calculated to find a linear approximation to the  $t_{OFF}$  equation:

$$\frac{dv_{COFF}(t)}{dt} = \frac{V_O}{R_{OFF} \times C_{OFF}} e^{-\left(\frac{t_{OFF}}{R_{OFF} \times C_{OFF}}\right)}$$

When  $t_{OFF} \ll R_{OFF} \times C_{OFF}$  (equivalent to when  $V_O \gg 1.24\text{V}$ ), the slope of the function is essentially linear and  $t_{OFF}$  can be approximated as a current source charging  $C_{OFF}$ :

$$t_{OFF} \approx \frac{1.24\text{V} \times R_{OFF} \times C_{OFF}}{V_O}$$

Using the actual  $t_{OFF}$  equation, the inductor current ripple ( $\Delta i_{L-PP}$ ) of a buck current regulator operating in CCM is:

$$\Delta i_{L-PP} = \frac{-V_O \times R_{OFF} \times (C_{OFF} + 20 \text{ pF}) \times \ln \left( 1 - \frac{1.24\text{V}}{V_O} \right)}{L1}$$

Using the  $t_{OFF}$  approximation, the equation is reduced to:

$$\Delta i_{L-PP} \approx \frac{1.24 \times R_{OFF} \times C_{OFF}}{L1}$$

**$\Delta i_{L-PP}$  is independent of both  $V_{IN}$  and  $V_O$  when in CCM!**

The  $\Delta i_{L-PP}$  approximation only depends on  $R_{OFF}$ ,  $C_{OFF}$ , and  $L1$ , therefore the ripple is essentially constant over the operating range as long as  $V_O \gg 1.24\text{V}$  (when the  $t_{OFF}$  approximation is valid). An exception to the  $t_{OFF}$  approximation occurs if the IADJ pin is used to analog dim. As the LED/inductor current decreases, the converter will eventually enter DCM and the ripple will decrease with the peak current threshold. The approximation shows how the LM3409/09HV achieves constant ripple over a wide operating range, however  $t_{OFF}$  should be calculated using the actual equation first presented.

## AVERAGE LED CURRENT

For a buck converter, the average LED current is simply the average inductor current.

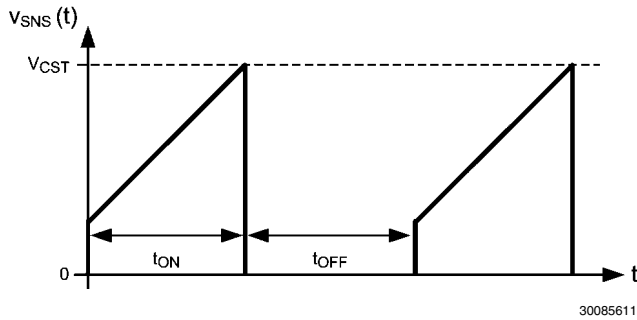

FIGURE 5. Sense Voltage  $v_{SNS}(t)$

Using the COFT architecture, the peak transistor current ( $I_{T-MAX}$ ) is sensed as shown in Figure 5, which is equal to the peak inductor current ( $I_{L-MAX}$ ) given by the following equation:

$$I_{L-MAX} = I_{T-MAX} = \frac{V_{CST}}{R_{SNS}} = \frac{V_{ADJ}}{5 \times R_{SNS}}$$

Because  $I_{L-MAX}$  is set using peak current control and  $\Delta i_{L-PP}$  is set using the controlled off-timer,  $I_L$  and correspondingly  $I_{LED}$  can be calculated as follows:

$$I_{LED} = I_L = I_{L-MAX} - \frac{\Delta i_{L-PP}}{2} = \frac{V_{ADJ}}{5 \times R_{SNS}} - \frac{V_O \times t_{OFF}}{2 \times L1}$$

The threshold voltage  $V_{CST}$  seen by the high-side sense comparator is affected by the comparator's input offset voltage, which causes an error in the calculation of  $I_{L-MAX}$  and ultimately  $I_{LED}$ . To mitigate this problem, the polarity of the comparator inputs is swapped every cycle, which causes the actual  $I_{L-MAX}$  to alternate between two peak values ( $I_{L-MAXH}$  and  $I_{L-MAXL}$ ), equidistant from the theoretical  $I_{L-MAX}$  as shown in Figure 6.  $I_{LED}$  remains accurate through this averaging.

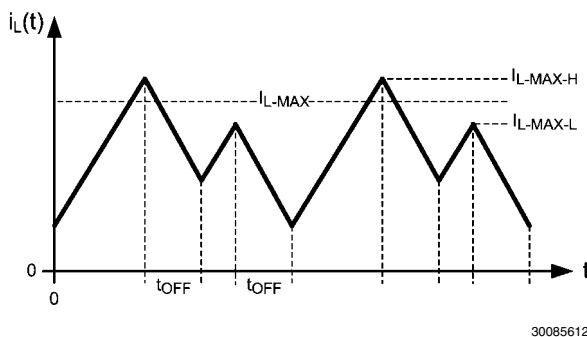

FIGURE 6. Inductor Current  $i_L(t)$  Showing  $I_{L-MAX}$  Offset

## INDUCTOR CURRENT RIPPLE

Because the LM3409/09HV swaps the polarity of the differential current sense comparator every cycle, a minimum inductor current ripple ( $\Delta i_{L-PP}$ ) is necessary to maintain accurate  $I_{LED}$  regulation. Referring to Figure 6, the first  $t_{ON}$  is terminated at the higher of the two polarity-swapped thresholds (corresponding to  $I_{L-MAXH}$ ). During the following  $t_{OFF}$ ,  $i_L$  decreases until the second  $t_{ON}$  begins. If  $t_{OFF}$  is too short, then as the second  $t_{ON}$  begins,  $i_L$  will still be above the lower peak current threshold (corresponding to  $I_{L-MAXL}$ ) and a minimum  $t_{ON}$  pulse will follow. This will result in degraded  $I_{LED}$  regulation. The minimum inductor current ripple ( $\Delta i_{L-PP-MIN}$ ) should adhere to the following equation in order to ensure accurate  $I_{LED}$  regulation:

$$\Delta i_{L-PP-MIN} > \frac{24 \text{ mV}}{R_{SNS}}$$

## SWITCHING FREQUENCY

The switching frequency is dependent upon the actual operating point ( $V_{IN}$  and  $V_O$ ).  $V_O$  will remain relatively constant for a given application, therefore the switching frequency will vary with  $V_{IN}$  (frequency increases as  $V_{IN}$  increases). The target switching frequency ( $f_{SW}$ ) at the nominal operating point is selected based on the tradeoffs between efficiency (better at low frequency) and solution size/cost (smaller at high frequency). The off-time of the LM3409/09HV can be programmed for switching frequencies up to 5 MHz (theoretical limit imposed by minimum  $t_{ON}$ ). In practice, switching frequencies higher than 1MHz may be difficult to obtain due to gate drive limitations, high input voltage, and thermal considerations.

At CCM operating points,  $f_{SW}$  is defined as:

$$f_{SW} = \frac{1-D}{t_{OFF}} = \frac{1 - \left( \frac{V_O}{\eta \times V_{IN}} \right)}{t_{OFF}}$$

At DCM operating points,  $f_{SW}$  is defined as:

$$f_{SW} = \frac{1}{t_{ON} + t_{OFF}} = \frac{1}{\left( \frac{I_{L-MAX} \times L1}{V_{IN} - V_O} \right) + t_{OFF}}$$

In the CCM equation, it is apparent that the efficiency ( $\eta$ ) factors into the switching frequency calculation. Efficiency is hard to estimate and, since switching frequency varies with input voltage, accuracy in setting the nominal switching frequency is not critical. Therefore, a general rule of thumb for the LM3409/09HV is to assume an efficiency between 85% and 100%. When approximating efficiency to target a nominal switching frequency, the following condition must be met:

$$\eta > \frac{V_O}{V_{IN}}$$

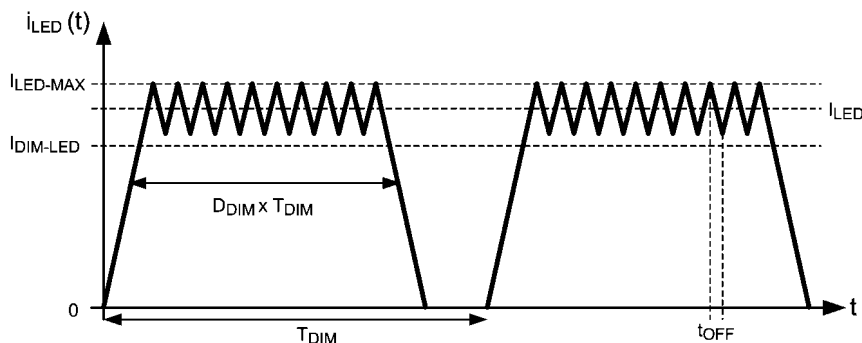

30085614

FIGURE 7. LED Current  $i_{LED}(t)$  During EN Pin PWM Dimming

### PWM DIMMING USING THE EN PIN

The enable pin (EN) is a TTL compatible input for PWM dimming of the LED. A logic low (below 0.5V) at EN will disable the internal driver and shut off the current flow to the LED array. While the EN pin is in a logic low state the support circuitry (driver, bandgap,  $V_{CC}$  regulator) remains active in order to minimize the time needed to turn the LED array back on when the EN pin sees a logic high (above 1.74V).

Figure 7 shows the LED current ( $i_{LED}(t)$ ) during PWM dimming where duty cycle ( $D_{DIM}$ ) is the percentage of the dimming period ( $T_{DIM}$ ) that the PFET is switching. For the remainder of  $T_{DIM}$ , the PFET is disabled. The resulting dimmed average LED current ( $I_{DIM-LED}$ ) is:

$$I_{DIM-LED} = D_{DIM} \times I_{LED}$$

The LED current rise and fall times (which are limited by the slew rate of the inductor as well as the delay from activation of the EN pin to the response of the external PFET) limit the achievable  $T_{DIM}$  and  $D_{DIM}$ . In general, dimming frequency should be at least one order of magnitude lower than the steady state switching frequency in order to prevent aliasing. However, for good linear response across the entire dimming range, the dimming frequency may need to be even lower.

### HIGH VOLTAGE NEGATIVE BIAS REGULATOR

The LM3409/09HV contains an internal linear regulator where the steady state  $V_{CC}$  pin voltage is typically 6.2V below the voltage at the  $V_{IN}$  pin. The  $V_{CC}$  pin should be bypassed to the  $V_{IN}$  pin with at least 1 $\mu$ F of ceramic capacitance connected as close as possible to the IC.

### INPUT UNDER-VOLTAGE LOCKOUT (UVLO)

Under-voltage lockout is set with a resistor divider from  $V_{IN}$  to GND and is compared against a 1.24V threshold as shown in Figure 8. Once the input voltage is above the preset UVLO rising threshold (and assuming the part is enabled), the internal circuitry becomes active and a 22 $\mu$ A current source at the UVLO pin is turned on. This extra current provides hysteresis to create a lower UVLO falling threshold. The resistor divider is chosen to set both the UVLO rising and falling thresholds.

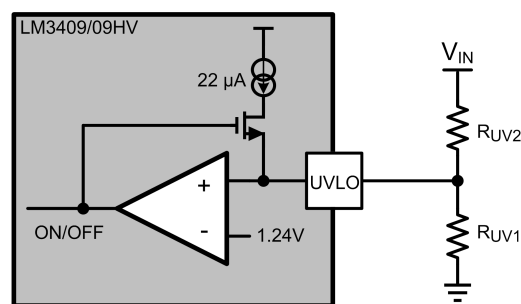

30085613

FIGURE 8. UVLO Circuit

The turn-on threshold ( $V_{TURN-ON}$ ) is defined as follows:

$$V_{TURN-ON} = \frac{1.24V \times (R_{UV1} + R_{UV2})}{R_{UV1}}$$

The hysteresis ( $V_{HYS}$ ) is defined as follows:

$$V_{HYS} = R_{UV2} \times 22 \mu A$$

### LOW POWER SHUTDOWN

The LM3409/09HV can be placed into a low power shutdown (typically 110 $\mu$ A) by grounding the EN terminal (any voltage below 0.5V) until  $V_{CC}$  drops below the  $V_{CC}$  UVLO threshold (typically 3.73V). During normal operation this terminal should be tied to a voltage above 1.74V and below absolute maximum input voltage rating.

### THERMAL SHUTDOWN

Internal thermal shutdown circuitry is provided to protect the IC in the event that the maximum junction temperature is exceeded. The threshold for thermal shutdown is 160°C with 15°C of hysteresis (both values typical). During thermal shutdown the PFET and driver are disabled.

## Design Considerations

### OPERATION NEAR DROPOUT

Because the power MosFET is a PFET, the LM3409/09HV can be operated into dropout which occurs when the input voltage is approximately equal to output voltage. Once the input voltage drops below the nominal output voltage, the switch remains constantly on ( $D=1$ ) causing the output voltage to decrease with the input voltage. In normal operation, the average LED current is regulated to the peak current threshold minus half of the ripple. As the converter goes into dropout, the LED current is exactly at the peak current threshold because it is no longer switching. This causes the LED current to increase by half of the set ripple current as it makes the transition into dropout. Therefore, the inductor current ripple should be kept as small as possible (while remaining above the previously established minimum) and output capacitance should be added to help maintain good line regulation when approaching dropout.

### LED RIPPLE CURRENT

Selection of the ripple current through the LED array is analogous to the selection of output ripple voltage in a standard voltage regulator. Where the output voltage ripple in a voltage regulator is commonly  $\pm 1\%$  to  $\pm 5\%$  of the DC output voltage, LED manufacturers generally recommend values for  $\Delta i_{LED-PP}$  ranging from  $\pm 5\%$  to  $\pm 20\%$  of  $I_{LED}$ . For a nominal system operating point, a larger  $\Delta i_{LED-PP}$  specification can reduce the necessary inductor size and/or allow for smaller output capacitors (or no output capacitors at all) which helps to minimize the total solution size and cost. On the other hand, a smaller  $\Delta i_{LED-PP}$  specification would require more output inductance, a higher switching frequency, or additional output capacitance.

### BUCK CONVERTERS W/O OUTPUT CAPACITORS

Because current is being regulated, not voltage, a buck current regulator is free of load current transients, therefore output capacitance is not needed to supply the load and maintain output voltage. This is very helpful when high frequency PWM dimming the LED load. When no output capacitor is used, the same design equations that govern  $\Delta i_{L-PP}$  also apply to  $\Delta i_{LED-PP}$ .

### BUCK CONVERTERS WITH OUTPUT CAPACITORS

A capacitor placed in parallel with the LED load can be used to reduce  $\Delta i_{LED-PP}$  while keeping the same average current through both the inductor and the LED array. With an output capacitor, the inductance can be lowered, making the magnetics smaller and less expensive. Alternatively, the circuit can be run at lower frequency with the same inductor value, improving the efficiency and increasing the maximum allowable average output voltage. A parallel output capacitor is also useful in applications where the inductor or input voltage tolerance is poor. Adding a capacitor that reduces  $\Delta i_{LED-PP}$  to well below the target provides headroom for changes in inductance or  $V_{IN}$  that might otherwise push the maximum  $\Delta i_{LED-PP}$  too high.

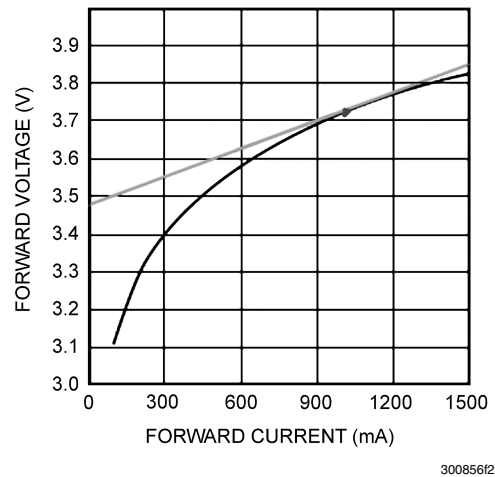

FIGURE 9. Calculating Dynamic Resistance  $r_D$

Output capacitance ( $C_O$ ) is determined knowing the desired  $\Delta i_{LED-PP}$  and the LED dynamic resistance ( $r_D$ ).  $r_D$  can be calculated as the slope of the LED's exponential DC characteristic at the nominal operating point as shown in Figure 9. Simply dividing the forward voltage by the forward current at the nominal operating point will give an incorrect value that is 5x to 10x too high. Total dynamic resistance for a string of  $n$  LEDs connected in series can be calculated as the  $r_D$  of one device multiplied by  $n$ . The following equations can then be used to estimate  $\Delta i_{LED-PP}$  when using a parallel capacitor:

$$\Delta i_{LED-PP} = \frac{\Delta i_{L-PP}}{1 + \frac{r_D}{Z_C}}$$

$$Z_C = \frac{1}{2 \times \pi \times f_{SW} \times C_O}$$

In general,  $Z_C$  should be at least half of  $r_D$  to effectively reduce the ripple. Ceramic capacitors are the best choice for the output capacitors due to their high ripple current rating, low ESR, low cost, and small size compared to other types. When selecting a ceramic capacitor, special attention must be paid to the operating conditions of the application. Ceramic capacitors can lose one-half or more of their capacitance at their rated DC voltage bias and also lose capacitance with extremes in temperature. Make sure to check any recommended deratings and also verify if there is any significant change in capacitance at the operating voltage and temperature.

### OUTPUT OVER-VOLTAGE PROTECTION

Because the LM3409/09HV controls a buck current regulator, there is no inherent need to provide output over-voltage protection. If the LED load is opened, the output voltage will only rise as high as the input voltage plus any ringing due to the parasitic inductance and capacitance present at the output node. If a ceramic output capacitor is used in the application, it should have a minimum rating equal to the input voltage. Ringing seen at the output node should not damage most ceramic capacitors, due to their high ripple current rating.

## INPUT CAPACITORS

Input capacitors are selected using requirements for minimum capacitance and RMS ripple current. The PFET current during  $t_{ON}$  is approximately  $I_{LED}$ , therefore the input capacitors discharge the difference between  $I_{LED}$  and the average input current ( $I_{IN}$ ) during  $t_{ON}$ . During  $t_{OFF}$ , the input voltage source charges up the input capacitors with  $I_{IN}$ . The minimum input capacitance ( $C_{IN-MIN}$ ) is selected using the maximum input voltage ripple ( $\Delta V_{IN-MAX}$ ) which can be tolerated.  $\Delta V_{IN-MAX}$  is equal to the change in voltage across  $C_{IN}$  during  $t_{ON}$  when it supplies the load current. A good starting point for selection of  $C_{IN}$  is to use  $\Delta V_{IN-MAX}$  of 2% to 10% of  $V_{IN}$ .  $C_{IN-MIN}$  can be selected as follows:

$$C_{IN-MIN} = \frac{I_{LED} \times t_{ON}}{\Delta V_{IN-MAX}} = \frac{I_{LED} \times \left( \frac{1}{f_{SW}} - t_{OFF} \right)}{\Delta V_{IN-MAX}}$$

An input capacitance at least 75% greater than the calculated  $C_{IN-MIN}$  value is recommended. To determine the RMS input current rating ( $I_{IN-RMS}$ ) the following approximation can be used:

$$I_{IN-RMS} = I_{LED} \times \sqrt{D \times (1 - D)} = I_{LED} \times f_{SW} \times \sqrt{t_{ON} \times t_{OFF}}$$

Since this approximation assumes there is no inductor ripple current, the value should be increased by 10-30% depending on the amount of ripple that is expected. Ceramic capacitors are the best choice for input capacitors for the same reasons mentioned in the *Buck Converters with Output Capacitors* section. Careful selection of the capacitor requires checking capacitance ratings at the nominal operating voltage and temperature.

## P-CHANNEL MosFET (PFET)

The LM3409/09HV requires an external PFET (Q1) as the main power MosFET for the switching regulator. Q1 should have a voltage rating at least 15% higher than the maximum input voltage to ensure safe operation during the ringing of the switch node. In practice all switching converters have some ringing at the switch node due to the diode parasitic capacitance and the lead inductance. The PFET should also have a current rating at least 10% higher than the average transistor current ( $I_T$ ):

$$I_T = D \times I_{LED}$$

The power rating is verified by calculating the power loss ( $P_T$ ) using the RMS transistor current ( $I_{T-RMS}$ ) and the PFET on-resistance ( $R_{DS-ON}$ ):

$$I_{T-RMS} = I_{LED} \times \sqrt{D \times \left( 1 + \frac{1}{12} \times \left( \frac{\Delta i_{L-PP}}{I_{LED}} \right)^2 \right)}$$

$$P_T = I_{T-RMS}^2 \times R_{DS-ON}$$

It is important to consider the gate charge of Q1. As the input voltage increases from a nominal voltage to its maximum input voltage, the COFT architecture will naturally increase the switching frequency. The dominant switching losses are determined by input voltage, switching frequency, and PFET total gate charge ( $Q_g$ ). The LM3409/09HV has to provide and remove charge  $Q_g$  from the input capacitance of Q1 in order to turn it on and off. This occurs more often at higher switching frequencies which requires more current from the internal regulator, thereby increasing internal power dissipation and eventually causing the LM3409/09HV to thermally cycle. For a given range of operating points the only effective way to reduce these switching losses is to minimize  $Q_g$ .

A good rule of thumb is to limit  $Q_g < 30nC$  (if the switching frequency remains below 300kHz for the entire operating range then a larger  $Q_g$  can be considered). If a PFET with small  $R_{DS-ON}$  and a high voltage rating is required, there may be no choice but to use a PFET with  $Q_g > 30nC$ .

When using a PFET with  $Q_g > 30nC$ , the bypass capacitor ( $C_F$ ) should not be connected to the VIN pin. This will ensure that peak current detection through  $R_{SNS}$  is not affected by the charging of the PFET input capacitance during switching, which can cause false triggering of the peak detection comparator. Instead,  $C_F$  should be connected from the VCC pin to the CSN pin which will cause a small DC offset in  $V_{CST}$  and ultimately  $I_{LED}$ , however it avoids the problematic false triggering.

In general, the PFET should be chosen to meet the  $Q_g$  specification whenever possible, while minimizing  $R_{DS-ON}$ . This will minimize power losses while ensuring the part functions correctly over the full operating range.

## RE-CIRCULATING DIODE

A re-circulating diode (D1) is required to carry the inductor current during  $t_{OFF}$ . The most efficient choice for D1 is a Schottky diode due to low forward voltage drop and near-zero reverse recovery time. Similar to Q1, D1 must have a voltage rating at least 15% higher than the maximum input voltage to ensure safe operation during the ringing of the switch node and a current rating at least 10% higher than the average diode current ( $I_D$ ):

$$I_D = (1 - D) \times I_{LED}$$

The power rating is verified by calculating the power loss through the diode. This is accomplished by checking the typical diode forward voltage ( $V_D$ ) from the I-V curve on the product datasheet and calculating as follows:

$$P_D = I_D \times V_D$$

In general, higher current diodes have a lower  $V_D$  and come in better performing packages minimizing both power losses and temperature rise.

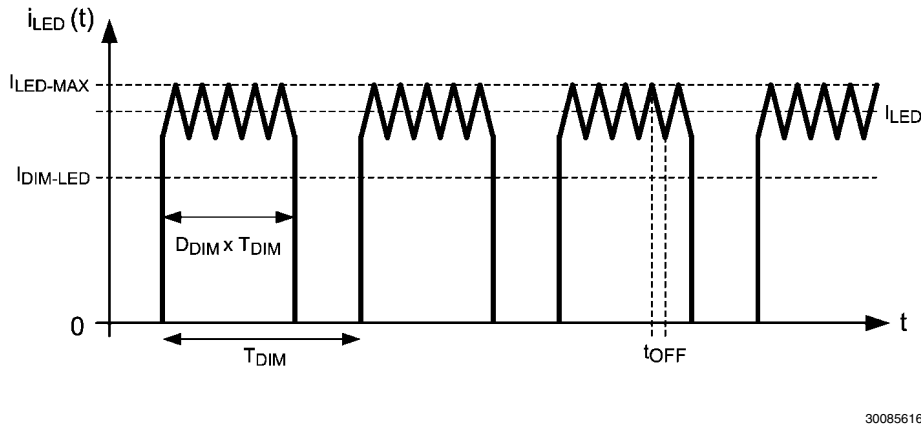
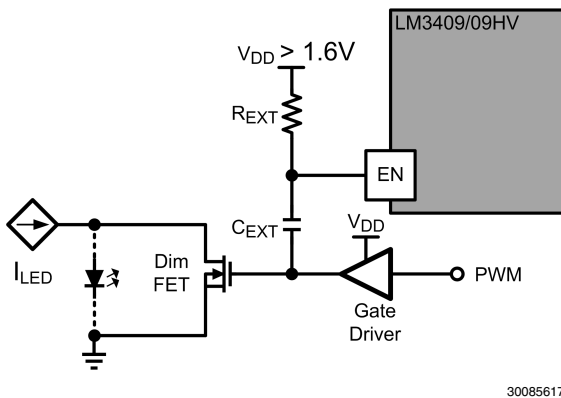

FIGURE 10. Ideal LED Current  $i_{LED}(t)$  During Parallel FET Dimming

30085616

### EXTERNAL PARALLEL FET PWM DIMMING

Any buck topology LED driver is a good candidate for parallel FET dimming because high slew rates are achievable, due to the fact that no output capacitance is required. This allows for much higher dimming frequencies than are achievable using the EN pin. When using external parallel FET dimming, a situation can arise where maximum off-time occurs due to a shorted output. To mitigate this situation, capacitive coupling to the enable pin can be employed.



30085617

FIGURE 11. External Parallel FET Dimming Circuit

As shown in *Figure 11*, a small capacitor ( $C_{EXT}$ ) is connected from the gate drive signal of the parallel Dim FET to the EN pin and a pull-up resistor ( $R_{EXT}$ ) is placed from the EN pin to the external  $V_{DD}$  supply for the Dim FET gate driver. This forces the on-timer to restart corresponding to every rising edge of the LED voltage, ensuring that the unwanted maximum off-time condition does not occur. With this type of dimming, the EN pin does not control the dimming; it simply resets the controller. A good design choice is to size  $R_{EXT}$  and  $C_{EXT}$  to give a time constant smaller than  $t_{OFF}$ :

$$t_{OFF} > R_{EXT} \times C_{EXT}$$

The ideal LED current waveform  $i_{LED}(t)$  during parallel FET PWM dimming is very similar to the EN pin PWM dimming shown previously. The LED current does not rise and fall infinitely fast as shown in *Figure 10* however with this method, only the speed of the parallel Dim FET ultimately limits the dimming frequency and dimming duty cycle. This allows for much faster PWM dimming than can be attained with the EN pin.

### CIRCUIT LAYOUT

The performance of any switching converter depends as much upon the layout of the PCB as the component selection. Following a few simple guidelines will maximize noise rejection and minimize the generation of EMI within the circuit. Discontinuous currents are the most likely to generate EMI, therefore care should be taken when routing these paths. The main path for discontinuous current in the LM3409/09HV buck converter contains the input capacitor ( $C_{IN}$ ), the recirculating diode (D1), the P-channel MosFET (Q1), and the sense resistor ( $R_{SNS}$ ). This loop should be kept as small as possible and the connections between all three components should be short and thick to minimize parasitic inductance. In particular, the switch node (where L1, D1 and Q1 connect) should be just large enough to connect the components without excessive heating from the current it carries.

The IADJ, COFF, CSN and CSP pins are all high-impedance control inputs which couple external noise easily, therefore the loops containing these high impedance nodes should be minimized. The most sensitive loop contains the sense resistor ( $R_{SNS}$ ) which should be placed as close as possible to the CSN and CSP pins to maximize noise rejection. The off-time capacitor ( $C_{OFF}$ ) should be placed close to the COFF and GND pins for the same reason. Finally, if an external resistor ( $R_{EXT}$ ) is used to bias the IADJ pin, it should be placed close to the IADJ and GND pins, also.

In some applications the LED or LED array can be far away (several inches or more) from the LM3409/09HV, or on a separate PCB connected by a wiring harness. When an output capacitor is used and the LED array is large or separated from the rest of the converter, the output capacitor should be placed close to the LEDs to reduce the effects of parasitic inductance on the AC impedance of the capacitor.

## Design Guide

### TYPICAL APPLICATION

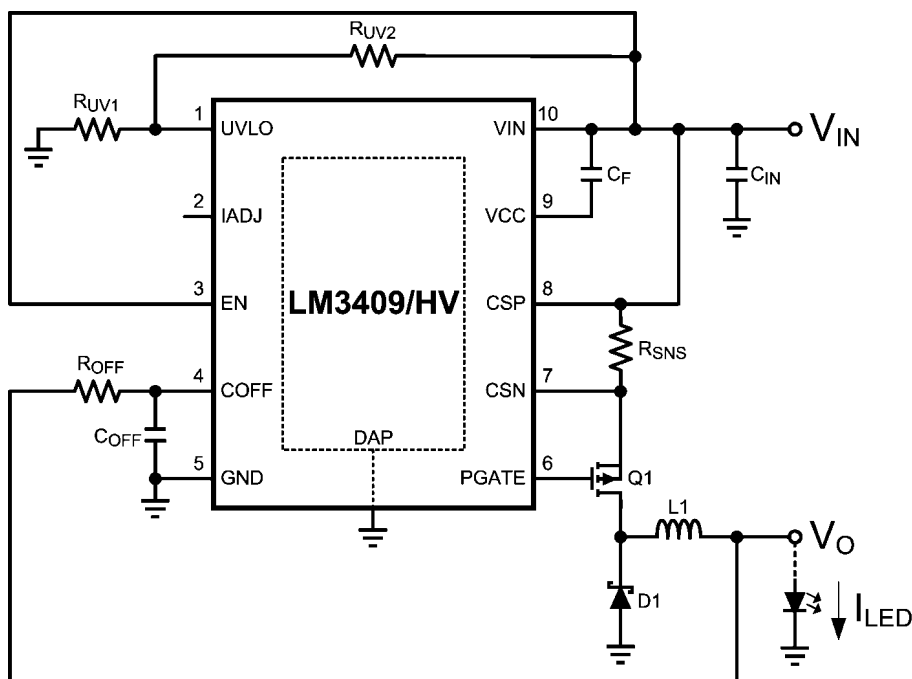

30085601

### SPECIFICATIONS

Nominal input voltage:  $V_{IN}$   
 Maximum input voltage:  $V_{IN-MAX}$   
 Nominal output voltage (# of LEDs x forward voltage):  $V_O$   
 LED string dynamic resistance:  $r_D$   
 Switching frequency (at nominal  $V_{IN}$ ,  $V_O$ ):  $f_{SW}$   
 Average LED current:  $I_{LED}$   
 Inductor current ripple:  $\Delta i_{L-PP}$   
 LED current ripple:  $\Delta i_{LED-PP}$   
 Input voltage ripple:  $\Delta V_{IN-PP}$   
 UVLO characteristics:  $V_{TURN-ON}$  and  $V_{HYS}$   
 Expected efficiency:  $\eta$

#### 1. NOMINAL SWITCHING FREQUENCY

Calculate switching frequency ( $f_{SW}$ ) at the nominal operating point ( $V_{IN}$  and  $V_O$ ). Assume a  $C_{OFF}$  value (between 470pF and 1nF) and a system efficiency ( $\eta$ ). Solve for  $R_{OFF}$ :

$$R_{OFF} = \frac{-\left(1 - \frac{V_O}{\eta \times V_{IN}}\right)}{(C_{OFF} + 20 \text{ pF}) \times f_{SW} \times \ln\left(1 - \frac{1.24V}{V_O}\right)}$$

#### 2. INDUCTOR RIPPLE CURRENT

Set the inductor ripple current ( $\Delta i_{L-PP}$ ) by solving for the appropriate inductor (L1):

$$L1 = \frac{V_O \times t_{OFF}}{\Delta i_{L-PP}}$$

#### 3. AVERAGE LED CURRENT

Set the average LED current ( $I_{LED}$ ) by first solving for the peak inductor current ( $I_{L-MAX}$ ):

$$I_{L-MAX} = I_{LED} + \frac{\Delta i_{L-PP}}{2}$$

Peak inductor current is detected across the sense resistor ( $R_{SNS}$ ). In most cases, assume the maximum value ( $V_{ADJ} = 1.24V$ ) at the IADJ pin and solve for  $R_{SNS}$ :

$$R_{SNS} = \frac{V_{ADJ}}{5 \times I_{L-MAX}}$$

If the calculated  $R_{SNS}$  is far from a standard value, the beginning of the process can be iterated to choose a new  $R_{OFF}$ , L1, and  $R_{SNS}$  value that is a closer fit. The easiest way to approach the iterative process is to change the nominal  $f_{SW}$  target knowing that the switching frequency varies with operating conditions anyways.

Another method for finding a standard  $R_{SNS}$  value is to change the  $V_{ADJ}$  value. However, this would require an external voltage source or a resistor from the IADJ pin to GND as explained in the *Theory of Operation* section of this datasheet.



#### 4. OUTPUT CAPACITANCE

A minimum output capacitance ( $C_{O-MIN}$ ) may be necessary to reduce  $\Delta i_{LED-PP}$  below  $\Delta i_{L-PP}$ . With the specified  $\Delta i_{LED-PP}$  and the known dynamic resistance ( $r_D$ ) of the LED string, solve for the required impedance ( $Z_C$ ) for  $C_{O-MIN}$ :

$$Z_C = \frac{r_D \times \Delta i_{LED-PP}}{\Delta i_{L-PP} - \Delta i_{LED-PP}}$$

Solve for  $C_{O-MIN}$ :

$$C_{O-MIN} = \frac{1}{2 \times \pi \times f_{SW} \times Z_C}$$

#### 5. INPUT CAPACITANCE

Set the input voltage ripple ( $\Delta v_{IN-PP}$ ) by solving for the required minimum capacitance ( $C_{IN-MIN}$ ):

$$C_{IN-MIN} = \frac{I_{LED} \times t_{ON}}{\Delta v_{IN-PP}} = \frac{I_{LED} \times \left( \frac{1}{f_{SW}} - t_{OFF} \right)}{\Delta v_{IN-PP}}$$

The necessary RMS input current rating ( $I_{IN-RMS}$ ) is:

$$I_{IN-RMS} = I_{LED} \times f_{SW} \times \sqrt{t_{ON} \times t_{OFF}}$$

#### 6. PFET

The PFET voltage rating should be at least 15% higher than the maximum input voltage ( $V_{IN-MAX}$ ) and current rating should be at least 10% higher than the average PFET current ( $I_T$ ):

$$I_T = D \times I_{LED}$$

Given a PFET with on-resistance ( $R_{DS-ON}$ ), solve for the RMS transistor current ( $I_{T-RMS}$ ) and power dissipation ( $P_T$ ):

$$I_{T-RMS} = I_{LED} \times \sqrt{D \times \left( 1 + \frac{1}{12} \times \left( \frac{\Delta i_{L-PP}}{I_{LED}} \right)^2 \right)}$$

$$P_T = I_{T-RMS}^2 \times R_{DS-ON}$$

#### 7. DIODE

The Schottky diode needs a voltage rating similar to the PFET. Higher current diodes with a lower forward voltage are suggested. Given a diode with forward voltage ( $V_D$ ), solve for the average diode current ( $I_D$ ) and power dissipation ( $P_D$ ):

$$I_D = (1 - D) \times I_{LED}$$

$$P_D = I_D \times V_D$$

#### 8. INPUT UVLO

Input UVLO is set with the turn-on threshold voltage ( $V_{TURN-ON}$ ) and the desired hysteresis ( $V_{HYS}$ ). To set  $V_{HYS}$ , solve for  $R_{UV2}$ :

$$R_{UV2} = \frac{V_{HYS}}{22 \mu A}$$

To set  $V_{TURN-ON}$ , solve for  $R_{UV1}$ :

$$R_{UV1} = \frac{1.24V \times R_{UV2}}{V_{TURN-ON} - 1.24V}$$

#### 9. IADJ CONNECTION METHOD

The IADJ pin controls the high-side current sense threshold in three ways outlined in the *Theory of Operation* section.

**Method #1:** Leave IADJ pin open and  $I_{LED}$  is calculated as in the *Average LED Current* section of the *Design Guide*.

**Method #2:** Apply an external voltage ( $V_{ADJ}$ ) to the IADJ pin between 0 and 1.24V to analog dim or to reduce  $I_{LED}$  as follows:

$$I_{LED} = \frac{V_{ADJ}}{5 \times R_{SNS}} - \frac{\Delta i_{L-PP}}{2}$$

Keep in mind that analog dimming will eventually push the converter in to DCM and the inductor current ripple will no longer be constant causing a divergence from linear dimming at low levels.

A 0.1 $\mu$ F capacitor connected from the IADJ pin to GND is recommended when using this method. It may also be necessary to have a 1k $\Omega$  series resistor with the capacitor to create an RC filter. The filter will help remove high frequency noise created by other connected circuitry.

**Method #3:** Connect an external resistor or potentiometer to GND ( $R_{EXT}$ ) and the internal 5 $\mu$ A current source will set the voltage. Again, a 0.1 $\mu$ F capacitor connected from the IADJ pin to GND is recommended. To set  $I_{LED}$ , solve for  $R_{EXT}$ :

$$R_{EXT} = \frac{\left( I_{LED} + \frac{\Delta i_{L-PP}}{2} \right) \times R_{SNS}}{1 \mu A}$$

#### 10. PWM DIMMING METHOD

There are two methods to PWM dim using the LM3409/09HV:

**Method #1:** Apply an external PWM signal to the EN terminal.

**Method #2:** Perform external parallel FET shunt dimming as detailed in the *External Parallel FET PWM Dimming* section.

## Design Example #1

### EN PIN PWM DIMMING APPLICATION FOR 10 LEDs

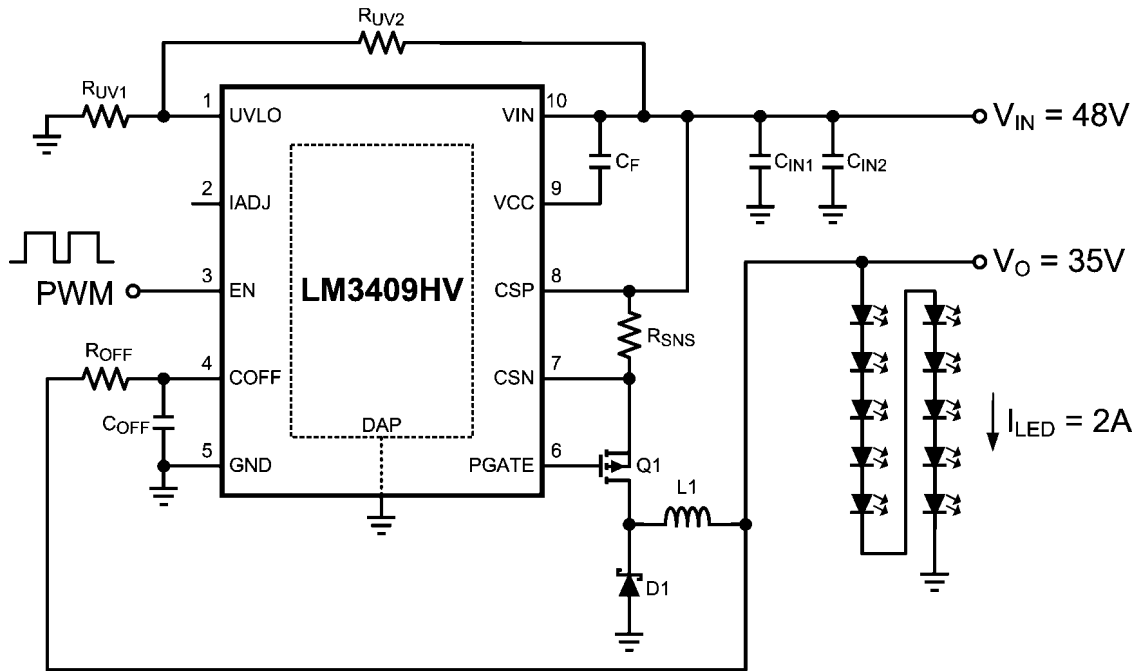

#### SPECIFICATIONS

$$f_{SW} = 525 \text{ kHz}$$

$$V_{IN} = 48 \text{ V}; V_{IN-MAX} = 75 \text{ V}$$

$$V_O = 35 \text{ V}$$

$$I_{LED} = 2 \text{ A}$$

$$\Delta i_{LED-PP} = \Delta i_{L-PP} = 1 \text{ A}$$

$$\Delta V_{IN-PP} = 1.44 \text{ V}$$

$$V_{TURN-ON} = 10 \text{ V}; V_{HYS} = 1.1 \text{ V}$$

$$\eta = 0.95$$

#### 1. NOMINAL SWITCHING FREQUENCY

Assume  $C_{OFF} = 470 \text{ pF}$  and  $\eta = 0.95$ . Solve for  $R_{OFF}$ :

$$R_{OFF} = \frac{-\left(1 - \frac{V_O}{\eta \times V_{IN}}\right)}{(C_{OFF} + 20 \text{ pF}) \times f_{SW} \times \ln\left(1 - \frac{1.24 \text{ V}}{V_O}\right)}$$

$$R_{OFF} = \frac{-\left(1 - \frac{35 \text{ V}}{0.95 \times 48 \text{ V}}\right)}{490 \text{ pF} \times 525 \text{ kHz} \times \ln\left(1 - \frac{1.24 \text{ V}}{35 \text{ V}}\right)} = 25.1 \text{ k}\Omega$$

The closest 1% tolerance resistor is 24.9 k $\Omega$  therefore the actual  $t_{OFF}$  and target  $f_{SW}$  are:

$$t_{OFF} = -(C_{OFF} + 20 \text{ pF}) \times R_{OFF} \times \ln\left(1 - \frac{1.24 \text{ V}}{V_O}\right)$$

$$t_{OFF} = -490 \text{ pF} \times 24.9 \text{ k}\Omega \times \ln\left(1 - \frac{1.24 \text{ V}}{35 \text{ V}}\right) = 440 \text{ ns}$$

$$f_{SW} = \frac{1 - \left(\frac{V_O}{\eta \times V_{IN}}\right)}{t_{OFF}} = \frac{1 - \left(\frac{35 \text{ V}}{0.95 \times 48 \text{ V}}\right)}{440 \text{ ns}} = 528 \text{ kHz}$$

30085618

The chosen components from step 1 are:

$$C_{OFF} = 470 \text{ pF}$$

$$R_{OFF} = 24.9 \text{ k}\Omega$$

#### 2. INDUCTOR RIPPLE CURRENT

Solve for L1:

$$L1 = \frac{V_O \times t_{OFF}}{\Delta i_{L-PP}} = \frac{35 \text{ V} \times 440 \text{ ns}}{1 \text{ A}} = 15.4 \mu\text{H}$$

The closest standard inductor value is 15  $\mu\text{H}$  therefore the actual  $\Delta i_{L-PP}$  is:

$$\Delta i_{L-PP} = \frac{V_O \times t_{OFF}}{L1} = \frac{35 \text{ V} \times 440 \text{ ns}}{15 \mu\text{H}} = 1.027 \text{ A}$$

The chosen component from step 2 is:

$$L1 = 15 \mu\text{H}$$

### 3. AVERAGE LED CURRENT

Determine  $I_{L-MAX}$ :

$$I_{L-MAX} = I_{LED} + \frac{\Delta i_{L-PP}}{2} = 2A + \frac{1.027A}{2} = 2.51A$$

Assume  $V_{ADJ} = 1.24V$  and solve for  $R_{SNS}$ :

$$R_{SNS} = \frac{V_{ADJ}}{5 \times I_{L-MAX}} = \frac{1.24V}{5 \times 2.51A} = 0.099\Omega$$

The closest 1% tolerance resistor is 0.1  $\Omega$  therefore the  $I_{LED}$  is:

$$I_{LED} = \frac{V_{ADJ}}{5 \times R_{SNS}} - \frac{\Delta i_{L-PP}}{2}$$

$$I_{LED} = \frac{1.24V}{5 \times 0.099\Omega} - \frac{1.027A}{2} = 1.97A$$

The chosen component from step 3 is:

$$R_{SNS} = 0.1\Omega$$

### 4. OUTPUT CAPACITANCE

No output capacitance is necessary.

### 5. INPUT CAPACITANCE

Determine  $t_{ON}$ :

$$t_{ON} = \frac{1}{f_{SW}} - t_{OFF} = \frac{1}{528 \text{ kHz}} - 440 \text{ ns} = 1.45\mu\text{s}$$

Solve for  $C_{IN-MIN}$ :

$$C_{IN-MIN} = \frac{I_{LED} \times t_{ON}}{\Delta V_{IN-PP}} = \frac{1.97A \times 1.45\mu\text{s}}{1.44V} = 1.98\mu\text{F}$$

Choose  $C_{IN}$ :

$$C_{IN} = C_{IN-MIN} \times 2 = 3.96\mu\text{F}$$

Determine  $I_{IN-RMS}$ :

$$I_{IN-RMS} = I_{LED} \times f_{SW} \times \sqrt{t_{ON} \times t_{OFF}}$$

$$I_{IN-RMS} = 1.97A \times 528 \text{ kHz} \times \sqrt{1.45\mu\text{s} \times 440 \text{ ns}} = 831 \text{ mA}$$

The chosen components from step 5 are:

$$C_{IN1} = C_{IN2} = 2.2\mu\text{F}$$

### 6. PFET

Determine minimum Q1 voltage rating and current rating:

$$V_{T-MAX} = V_{IN-MAX} = 75V$$

$$I_T = D \times I_{LED} = \frac{V_O \times I_{LED}}{V_{IN} \times \eta} = \frac{35V \times 1.97A}{48V \times 0.95} = 1.51A$$

A 100V, 3.8A PFET is chosen with  $R_{DS-ON} = 190\text{m}\Omega$  and  $Q_g = 20\text{nC}$ . Determine  $I_{T-RMS}$  and  $P_T$ :

$$I_{T-RMS} = I_{LED} \times \sqrt{D \times \left(1 + \frac{1}{12} \times \left(\frac{\Delta i_{L-PP}}{I_{LED}}\right)^2\right)}$$

$$I_{T-RMS} = 1.97A \times \sqrt{\frac{35V}{48V \times 0.95} \times \left(1 + \frac{1}{12} \times \left(\frac{1.027A}{1.97A}\right)^2\right)}$$

$$I_{T-RMS} = 1.74A$$

$$P_T = I_{T-RMS}^2 \times R_{DS-ON} = 1.74A^2 \times 190\text{m}\Omega = 577 \text{ mW}$$

The chosen component from step 6 is:

$$Q1 \rightarrow 3.8A, 100V, \text{ DPAK}$$

### 7. DIODE

Determine minimum D1 voltage rating and current rating:

$$V_{D-MAX} = V_{IN-MAX} = 75V$$

$$I_D = (1-D) \times I_{LED} = \left(1 - \frac{V_O}{V_{IN} \times \eta}\right) \times I_{LED}$$

$$I_D = \left(1 - \frac{35V}{48V \times 0.95}\right) \times 1.97A = 457 \text{ mA}$$

A 100V, 3A diode is chosen with  $V_D = 750\text{mV}$ . Determine  $P_D$ :

$$P_D = I_D \times V_D = 457 \text{ mA} \times 750 \text{ mV} = 343 \text{ mW}$$

The chosen component from step 7 is:

$$D1 \rightarrow 3A, 100V, \text{ SMC}$$

**8. INPUT UVLO**Solve for  $R_{UV2}$ :

$$R_{UV2} = \frac{V_{HYS}}{22 \mu A} = \frac{1.1V}{22 \mu A} = 50 k\Omega$$

The closest 1% tolerance resistor is 49.9 k $\Omega$  therefore  $V_{HYS}$  is:

$$V_{HYS} = R_{UV2} \times 22 \mu A = 49.9 k\Omega \times 22 \mu A = 1.1V$$

Solve for  $R_{UV1}$ :

$$R_{UV1} = \frac{1.24V \times R_{UV2}}{V_{TURN-ON} - 1.24V} = \frac{1.24V \times 49.9 k\Omega}{10V - 1.24V} = 7.06 k\Omega$$

The closest 1% tolerance resistor is 6.98 k $\Omega$  therefore  $V_{TURN-ON}$  is:

$$V_{TURN-ON} = \frac{1.24V \times (R_{UV1} + R_{UV2})}{R_{UV1}}$$

$$V_{TURN-ON} = \frac{1.24V \times (6.98 k\Omega + 49.9 k\Omega)}{6.98 k\Omega} = 10.1V$$

The chosen components from step 8 are:

$$R_{UV1} = 6.98 k\Omega$$

$$R_{UV2} = 49.9 k\Omega$$

**9. IADJ CONNECTION METHOD**The IADJ pin is left open forcing  $V_{ADJ} = 1.24V$ .**10. PWM DIMMING METHOD**PWM dimming signal pair is applied to the EN pin and GND at  $f_{DIM} = 1$  kHz.**Design #1 Bill of Materials**

Qty	Part ID	Part Value	Manufacturer	Part Number
1	LM3409HV	Buck controller	NSC	LM3409HVMY
2	$C_{IN1}, C_{IN2}$	2.2 $\mu$ F X7R 10% 100V	MURATA	GRM43ER72A225KA01 L
1	$C_F$	1.0 $\mu$ F X7R 10% 16V	TDK	C1608X7R1C105K
1	$C_{OFF}$	470pF X7R 10% 50V	TDK	C1608X7R1H471K
1	Q1	PMOS 100V 3.8A	ZETEX	ZXMP10A18KTC
1	D1	Schottky 100V 3A	VISHAY	SS3H10-E3/57T
1	L1	15 $\mu$ H 20% 4.2A	TDK	SLF12565T-150M4R2
1	$R_{OFF}$	24.9k $\Omega$ 1%	VISHAY	CRCW060324K9FKEA
1	$R_{UV1}$	6.98k $\Omega$ 1%	VISHAY	CRCW06036K98FKEA
1	$R_{UV2}$	49.9k $\Omega$ 1%	VISHAY	CRCW060349K9FKEA
1	$R_{SNS}$	0.1 $\Omega$ 1% 1W	VISHAY	WSL2512R1000FEA

## Design Example #2

### ANALOG DIMMING APPLICATION FOR 4 LEDs

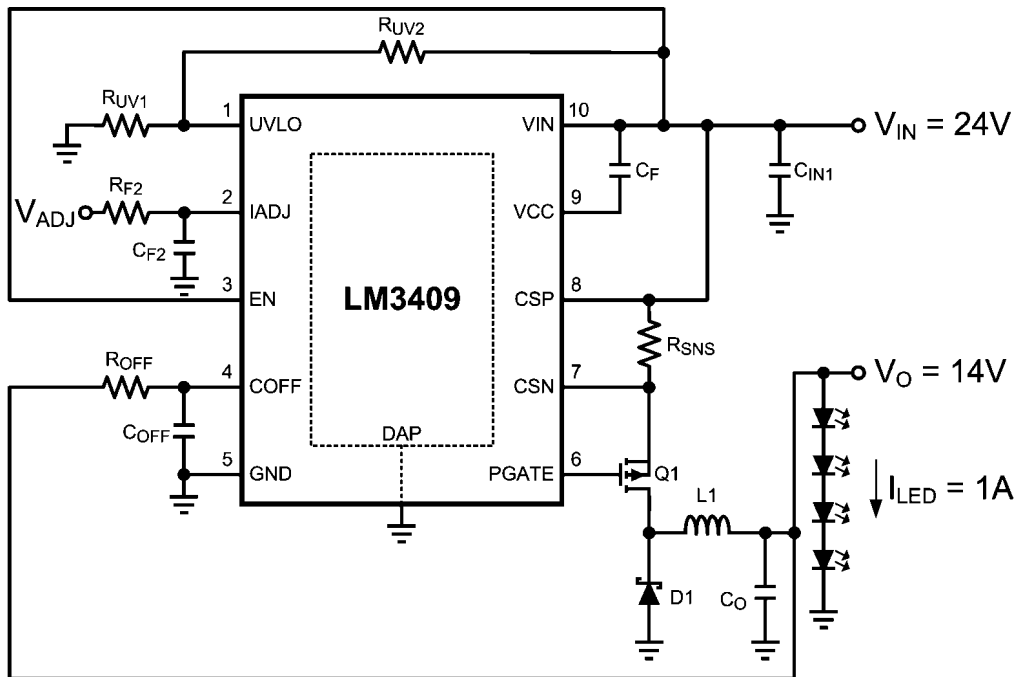

#### SPECIFICATIONS

$f_{SW} = 500\text{kHz}$   
 $V_{IN} = 24\text{V}; V_{IN-MAX} = 42\text{V}$   
 $V_O = 14\text{V}$   
 $I_{LED} = 1\text{A}$   
 $\Delta i_{L-PP} = 450\text{mA}; \Delta i_{LED-PP} = 50\text{mA}$   
 $\Delta V_{IN-PP} = 1\text{V}$   
 $V_{TURN-ON} = 10\text{V}; V_{HYS} = 1.1\text{V}$   
 $\eta = 0.90$

#### 1. NOMINAL SWITCHING FREQUENCY

Assume  $C_{OFF} = 470\text{pF}$  and  $\eta = 0.90$ . Solve for  $R_{OFF}$ :

$$R_{OFF} = \frac{-\left(1 - \frac{V_O}{\eta \times V_{IN}}\right)}{C_{OFF} + 20 \text{ pF} \times f_{SW} \times \ln\left(1 - \frac{1.24\text{V}}{V_O}\right)}$$

$$R_{OFF} = \frac{-\left(1 - \frac{14\text{V}}{0.90 \times 24\text{V}}\right)}{490 \text{ pF} \times 500 \text{ kHz} \times \ln\left(1 - \frac{1.24\text{V}}{14\text{V}}\right)} = 15.5 \text{ k}\Omega$$

The closest 1% tolerance resistor is 15.4 k $\Omega$  therefore the actual  $t_{OFF}$  and target  $f_{SW}$  are:

$$t_{OFF} = -(C_{OFF} + 20 \text{ pF}) \times R_{OFF} \times \ln\left(1 - \frac{1.24\text{V}}{V_O}\right)$$

$$t_{OFF} = -490 \text{ pF} \times 15.4 \text{ k}\Omega \times \ln\left(1 - \frac{1.24\text{V}}{14\text{V}}\right) = 700 \text{ ns}$$

$$f_{SW} = \frac{1 - \left(\frac{V_O}{\eta \times V_{IN}}\right)}{t_{OFF}} = \frac{1 - \left(\frac{14\text{V}}{0.90 \times 24\text{V}}\right)}{700 \text{ ns}} = 503 \text{ kHz}$$

The chosen components from step 1 are:

$$C_{OFF} = 470 \text{ pF}$$

$$R_{OFF} = 15.4 \text{ k}\Omega$$

#### 2. INDUCTOR RIPPLE CURRENT

Solve for L1:

$$L1 = \frac{V_O \times t_{OFF}}{\Delta i_{L-PP}} = \frac{14\text{V} \times 700 \text{ ns}}{450 \text{ mA}} = 21.8 \mu\text{H}$$

The closest standard inductor value is 22  $\mu\text{H}$  therefore the actual  $\Delta i_{L-PP}$  is:

$$\Delta i_{L-PP} = \frac{V_O \times t_{OFF}}{L1} = \frac{14\text{V} \times 700 \text{ ns}}{22 \mu\text{H}} = 445 \text{ mA}$$

The chosen component from step 2 is:

$$L1 = 22 \mu\text{H}$$

### 3. AVERAGE LED CURRENT

Determine  $I_{L-MAX}$ :

$$I_{L-MAX} = I_{LED} + \frac{\Delta i_{L-PP}}{2} = 1A + \frac{445 \text{ mA}}{2} = 1.22A$$

Assume  $V_{ADJ} = 1.24V$  and solve for  $R_{SNS}$ :

$$R_{SNS} = \frac{V_{ADJ}}{5 \times I_{L-MAX}} = \frac{1.24V}{5 \times 1.22A} = 0.203\Omega$$

The closest 1% tolerance resistor is  $0.2 \Omega$  therefore  $I_{LED}$  is:

$$I_{LED} = \frac{V_{ADJ}}{5 \times R_{SNS}} - \frac{\Delta i_{L-PP}}{2} = \frac{1.24V}{5 \times 0.2\Omega} - \frac{445 \text{ mA}}{2} = 1.02A$$

The chosen component from step 3 is:

$$R_{SNS} = 0.2\Omega$$

### 4. OUTPUT CAPACITANCE

Assume  $r_D = 2 \Omega$  and determine  $Z_C$ :

$$Z_C = \frac{r_D \times \Delta i_{LED-PP}}{\Delta i_{L-PP} - \Delta i_{LED-PP}} = \frac{2\Omega \times 50 \text{ mA}}{450 \text{ mA} - 50 \text{ mA}} = 250 \text{ m}\Omega$$

Solve for  $C_{O-MIN}$  and :

$$C_{O-MIN} = \frac{1}{2 \times \pi \times f_{SW} \times Z_C}$$

$$C_{O-MIN} = \frac{1}{2 \times \pi \times 503 \text{ kHz} \times 250 \text{ m}\Omega} = 1.27 \mu\text{F}$$

Choose  $C_O$ :

$$C_O = C_{O-MIN} \times 1.75 = 2.2 \mu\text{F}$$

The chosen component from step 5 is:

$$C_O = 2.2 \mu\text{F}$$

### 5. INPUT CAPACITANCE

Determine  $t_{ON}$ :

$$t_{ON} = \frac{1}{f_{SW}} - t_{OFF} = \frac{1}{503 \text{ kHz}} - 700 \text{ ns} = 1.29 \mu\text{s}$$

Solve for  $C_{IN-MIN}$ :

$$C_{IN-MIN} = \frac{I_{LED} \times t_{ON}}{\Delta V_{IN-PP}} = \frac{1.02A \times 1.29 \mu\text{s}}{720 \text{ mV}} = 1.82 \mu\text{F}$$

Choose  $C_{IN}$ :

$$C_{IN} = C_{IN-MIN} \times 2 = 3.64 \mu\text{F}$$

Determine  $I_{IN-RMS}$ :

$$I_{IN-RMS} = I_{LED} \times f_{SW} \times \sqrt{t_{ON} \times t_{OFF}}$$

$$I_{IN-RMS} = 1.02A \times 503 \text{ kHz} \times \sqrt{1.29 \mu\text{s} \times 700 \text{ ns}} = 486 \text{ mA}$$

The chosen component from step 5 is:

$$C_{IN} = 4.7 \mu\text{F}$$

### 6. PFET

Determine minimum Q1 voltage rating and current rating:

$$V_{T-MAX} = V_{IN-MAX} = 42V$$

$$I_T = D \times I_{LED} = \frac{V_O \times I_{LED}}{V_{IN} \times \eta} = \frac{14V \times 1.02A}{24V \times 0.90} = 660 \text{ mA}$$

A 70V, 5.7A PFET is chosen with  $R_{DS-ON} = 190\text{m}\Omega$  and  $Q_g = 20\text{nC}$ . Determine  $I_{T-RMS}$  and  $P_T$ :

$$I_{T-RMS} = I_{LED} \times \sqrt{D \times \left(1 + \frac{1}{12} \times \left(\frac{\Delta i_{L-PP}}{I_{LED}}\right)^2\right)}$$

$$I_{T-RMS} = 1.02A \times \sqrt{\frac{14V}{24V \times 0.90} \times \left(1 + \frac{1}{12} \times \left(\frac{445 \text{ mA}}{1.02A}\right)^2\right)}$$

$$I_{T-RMS} = 830 \text{ mA}$$

$$P_T = I_{T-RMS}^2 \times R_{DSON} = 830 \text{ mA}^2 \times 190 \text{ m}\Omega = 129 \text{ mW}$$

The chosen component from step 6 is:

$$Q1 \rightarrow 5.7A, 70V, \text{ DPAK}$$

### 7. DIODE

Determine minimum D1 voltage rating and current rating:

$$V_{D-MAX} = V_{IN-MAX} = 42V$$

$$I_D = (1 - D) \times I_{LED} = \left(1 - \frac{V_O}{V_{IN} \times \eta}\right) \times I_{LED}$$

$$I_D = \left(1 - \frac{14V}{24V \times 0.90}\right) \times 1.02A = 358 \text{ mA}$$

A 60V, 5A diode is chosen with  $V_D = 750\text{mV}$ . Determine  $P_D$ :

$$P_D = I_D \times V_D = 358 \text{ mA} \times 750 \text{ mV} = 268 \text{ mW}$$

The chosen component from step 7 is:

$$D1 \rightarrow 5A, 60V, \text{ SMC}$$

**8. INPUT UVLO**Solve for  $R_{UV2}$ :

$$R_{UV2} = \frac{V_{HYS}}{22 \mu A} = \frac{1.1V}{22 \mu A} = 50 k\Omega$$

The closest 1% tolerance resistor is 49.9 k $\Omega$  therefore  $V_{HYS}$  is:

$$V_{HYS} = R_{UV2} \times 22 \mu A = 49.9 k\Omega \times 22 \mu A = 1.1V$$

Solve for  $R_{UV1}$ :

$$R_{UV1} = \frac{1.24V \times R_{UV2}}{V_{TURN-ON} - 1.24V} = \frac{1.24V \times 49.9 k\Omega}{10V - 1.24V} = 7.06 k\Omega$$

The closest 1% tolerance resistor is 6.98 k $\Omega$  therefore  $V_{TURN-ON}$  is:

$$V_{TURN-ON} = \frac{1.24V \times (R_{UV1} + R_{UV2})}{R_{UV1}}$$

$$V_{TURN-ON} = \frac{1.24V \times (6.98 k\Omega + 49.9 k\Omega)}{6.98 k\Omega} = 10.1V$$

The chosen components from step 8 are:

$$R_{UV1} = 6.98 k\Omega$$

$$R_{UV2} = 49.9 k\Omega$$

**9. IADJ CONNECTION METHOD**The IADJ pin is connected to an external voltage source and varied from 0 – 1.24V to dim. An RC filter ( $R_{F2} = 1 k\Omega$  and  $C_{F2} = 0.1 \mu F$ ) is used as recommended.**10. PWM DIMMING METHOD**

No PWM dimming is necessary.

**Design #2 Bill of Materials**

Qty	Part ID	Part Value	Manufacturer	Part Number
1	LM3409	Buck controller	NSC	LM3409MY
2	$C_{IN1}$	4.7 $\mu F$ X7R 10% 50V	MURATA	GRM55ER71H475MA0 1L
1	$C_F$	1.0 $\mu F$ X7R 10% 16V	TDK	C1608X7R1C105K
1	$C_{F2}$	0.1 $\mu F$ X7R 10% 16V	TDK	C1608X7R1C104K
1	$C_{OFF}$	470pF X7R 10% 50V	TDK	C1608X7R1H471K
1	$C_O$	2.2 $\mu F$ X7R 10% 50V	MURATA	GRM43ER71H225MA0 1L
1	Q1	PMOS 70V 5.7A	ZETEX	ZXMP7A17KTC
1	D1	Schottky 60V 5A	COMCHIP	CDBC560-G
1	L1	22 $\mu H$ 20% 4.2A	TDK	SLF12575T-220M4R0
1	$R_{F2}$	1.0k $\Omega$ 1%	VISHAY	CRCW06031K00FKEA
1	$R_{OFF}$	15.4k $\Omega$ 1%	VISHAY	CRCW060315K4FKEA
1	$R_{UV1}$	6.98k $\Omega$ 1%	VISHAY	CRCW06036K98FKEA
1	$R_{UV2}$	49.9k $\Omega$ 1%	VISHAY	CRCW060349K9FKEA
1	$R_{SNS}$	0.2 $\Omega$ 1% 1W	VISHAY	WSL2512R2000FEA

## Applications Information

### DESIGN #3: EXTERNAL PARALLEL FET PWM DIMMING APPLICATION FOR 10 LEDs

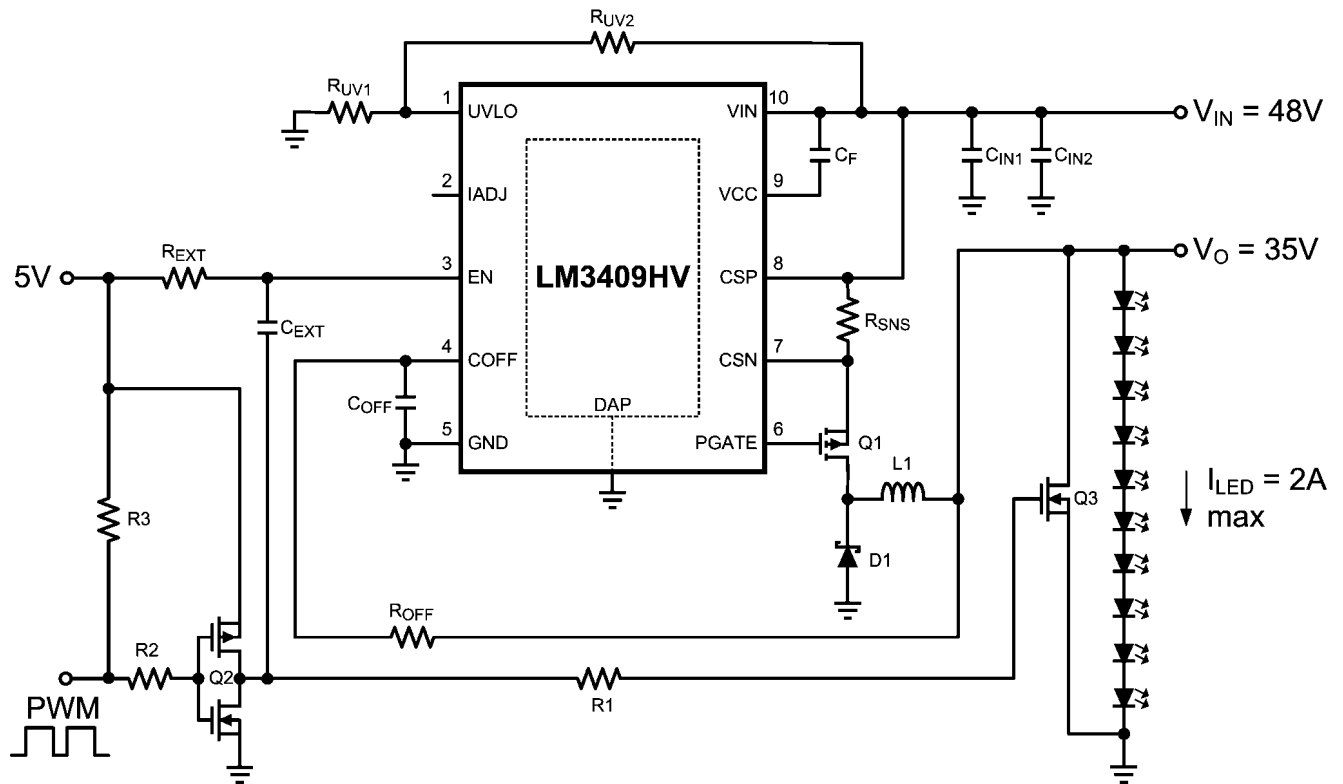

30085623

#### Design #3 Bill of Materials

Qty	Part ID	Part Value	Manufacturer	Part Number
1	LM3409HV	Buck controller	NSC	LM3409HVMY
2	C <sub>IN1</sub> , C <sub>IN2</sub>	2.2μF X7R 10% 100V	MURATA	GRM43ER72A225KA01 L
1	C <sub>F</sub>	1.0μF X7R 10% 16V	TDK	C1608X7R1C105K
1	C <sub>OFF</sub>	470pF X7R 10% 50V	TDK	C1608X7R1H471K
1	C1	2200pF X7R 10% 50V	MURATA	GRM188R71H222KA01 D
1	Q1	PMOS 100V 3.8A	ZETEX	ZXMP10A18KTC
1	Q2	CMOS 30V 2A	FAIRCHILD	FDC6333C
1	Q3	NMOS 100V 7.5A	FAIRCHILD	FDS3672
1	D1	Schottky 100V 3A	VISHAY	SS3H10-E3/57T
1	L1	15 μH 20% 4.2A	TDK	SLF12565T-150M4R2
2	R1, R2	1Ω 1%	VISHAY	CRCW06031R00FNEA
1	R3	10kΩ 1%	VISHAY	CRCW060310K0FKEA
1	R <sub>EXT</sub>	100Ω 1%	VISHAY	CRCW0603100RFKEA
1	R <sub>OFF</sub>	24.9kΩ 1%	VISHAY	CRCW060324K9FKEA
1	R <sub>UV1</sub>	6.98kΩ 1%	VISHAY	CRCW06036K98FKEA
1	R <sub>UV2</sub>	49.9kΩ 1%	VISHAY	CRCW060349K9FKEA
1	R <sub>SNS</sub>	0.1Ω 1% 1W	VISHAY	WSL2512R1000FEA



## DESIGN #4: SINGLE POTENTIOMETER ANALOG DIMMING APPLICATION FOR 6 LEDs

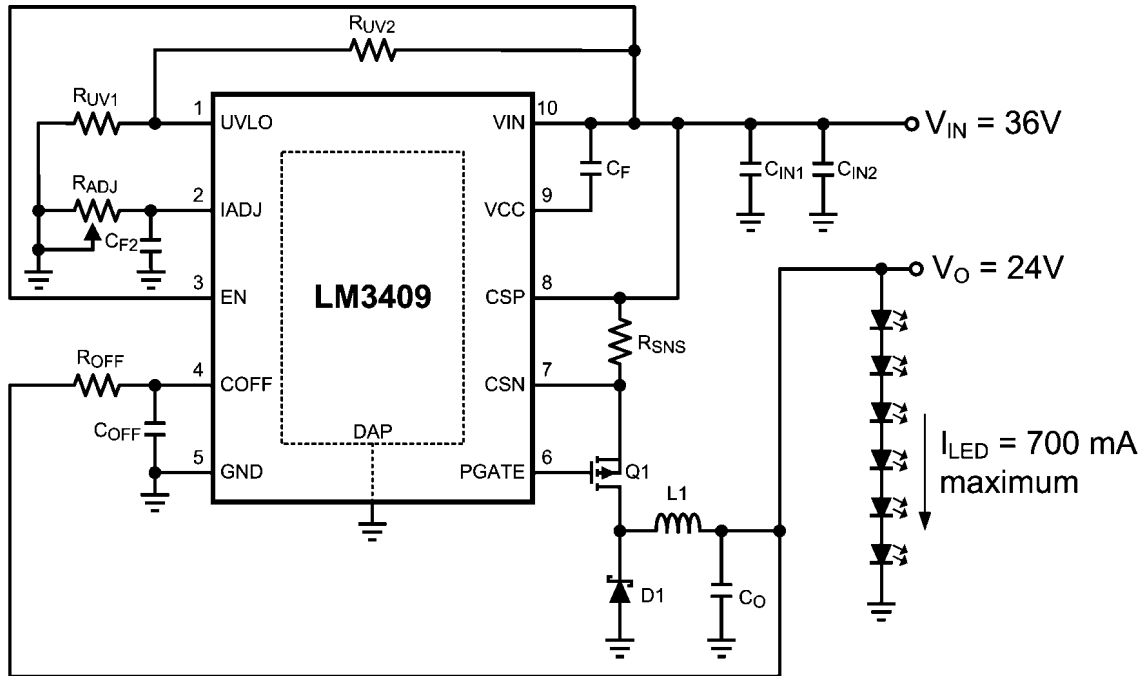

30085622

## Design #4 Bill of Materials

Qty	Part ID	Part Value	Manufacturer	Part Number
1	LM3409	Buck controller	NSC	LM3409MY
2	C <sub>IN1</sub> , C <sub>IN2</sub>	2.2µF X7R 10% 50V	MURATA	GRM43ER71H225MA0 1L
1	C <sub>F</sub>	1.0µF X7R 10% 16V	TDK	C1608X7R1C105K
1	C <sub>F2</sub>	0.1µF X7R 10% 16V	TDK	C1608X7R1C104K
1	C <sub>OFF</sub>	470pF X7R 10% 50V	TDK	C1608X7R1H471K
1	C <sub>O</sub>	1.0µF X7R 10% 50V	MURATA	GRM32RR71H105KA0 1L
1	Q1	PMOS 60V 3A	ZETEX	ZXMP6A17GTA
1	D1	Schottky 60V 2A	ST-MICRO	STPS2L60A
1	L1	68 µH 20% 2A	TDK	SLF12565T-680M2R0
1	R <sub>OFF</sub>	25.5kΩ 1%	VISHAY	CRCW060325K5FKEA
1	R <sub>UV1</sub>	6.98kΩ 1%	VISHAY	CRCW06036K98FKEA
1	R <sub>UV2</sub>	49.9kΩ 1%	VISHAY	CRCW060349K9FKEA
1	R <sub>SNS</sub>	0.3Ω 1% 1W	VISHAY	WSL2512R3000FEA
1	R <sub>ADJ</sub>	250kΩ potentiometer	BOURNS	3352P-1-254

## DESIGN #5: 75°C THERMAL FOLDBACK APPLICATION FOR 16 LEDs

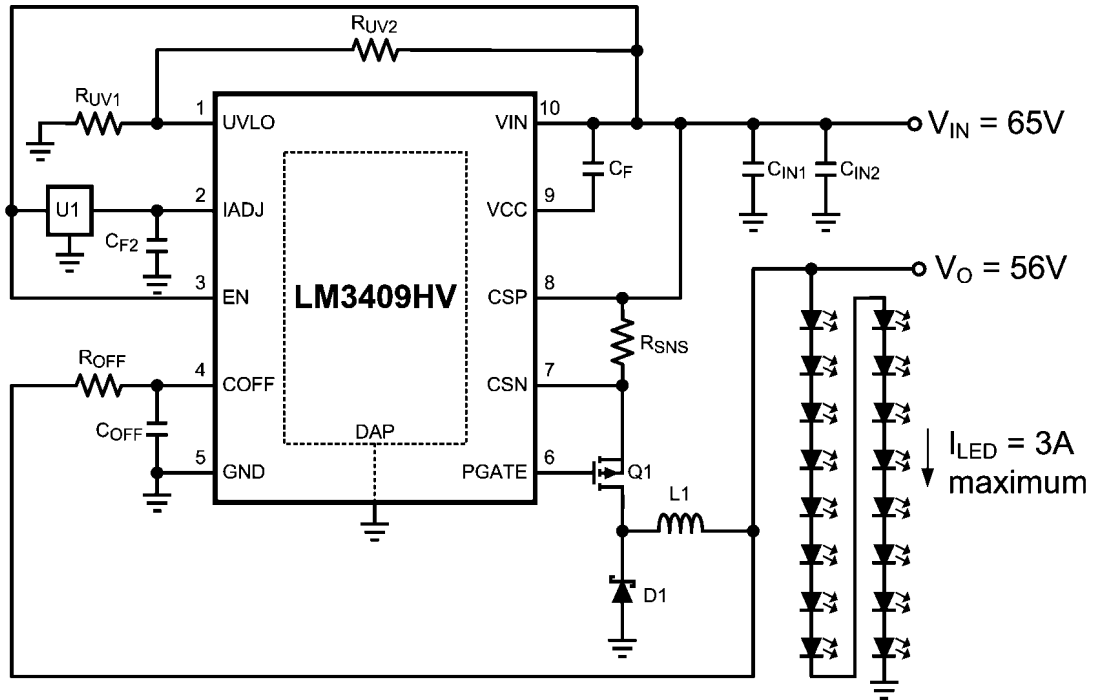

30085624

## Design #5 Bill of Materials

Qty	Part ID	Part Value	Manufacturer	Part Number
1	LM3409HV	Buck controller	NSC	LM3409HVMY
1	U1	Analog Temperature Sensor	NSC	LM94022
2	C <sub>IN1</sub> , C <sub>IN2</sub>	2.2μF X7R 10% 100V	MURATA	GRM43ER72A225KA01 L
1	C <sub>F</sub>	1.0μF X7R 10% 16V	TDK	C1608X7R1C105K
1	C <sub>F2</sub>	0.1μF X7R 10% 16V	TDK	C1608X7R1C104K
1	C <sub>OFF</sub>	470pF X7R 10% 50V	TDK	C1608X7R1H471K
1	Q1	PMOS 100V 3.8A	ZETEX	ZXMP10A18KTC
1	D1	Schottky 100V 3A	COMCHIP	SS3H10-E3/57T
1	L1	15 μH 20% 4.7A	TDK	SLF12575T-150M4R7
1	R <sub>OFF</sub>	24.9kΩ 1%	VISHAY	CRCW060324K9FKEA
1	R <sub>UV1</sub>	6.98kΩ 1%	VISHAY	CRCW06036K98FKEA
1	R <sub>UV2</sub>	49.9kΩ 1%	VISHAY	CRCW060349K9FKEA
1	R <sub>SNS</sub>	0.07Ω 1% 1W	VISHAY	WSL2512R0700FEA

\*U2 could be replaced with a 500kΩ NTC thermistor connected from IADJ to GND.

## DESIGN #6: HIGH CURRENT APPLICATION FOR 4 LEDs

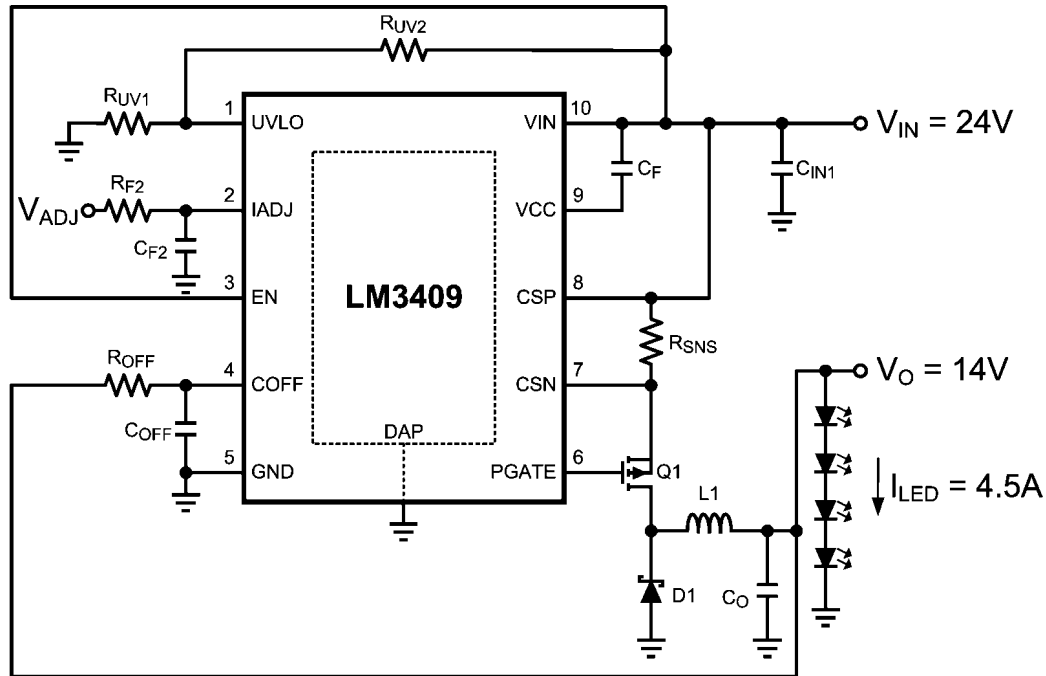

30085614

## Design #6 Bill of Materials

Qty	Part ID	Part Value	Manufacturer	Part Number
1	LM3409	Buck controller	NSC	LM3409MY
	C <sub>IN1</sub>	10µF X7R 10% 50V	TDK	C5750X7R1H106K
1	C <sub>F</sub>	1.0µF X7R 10% 16V	TDK	C1608X7R1C105K
1	C <sub>F2</sub>	0.1µF X7R 10% 16V	TDK	C1608X7R1C104K
1	C <sub>OFF</sub>	470pF X7R 10% 50V	TDK	C1608X7R1H471K
1	C <sub>O</sub>	1.0µF X7R 10% 50V	MURATA	GRM32RR71H105KA01L
1	Q1	PMOS 30V 24A	ST-MICRO	STD30PF03LT4
1	D1	Schottky 30V 5A	VISHAY	SSC53L-E3/57T
1	L1	15 µH 20% 7.5A	COILCRAFT	DO5022P-153ML
1	R <sub>F2</sub>	1.0kΩ 1%	VISHAY	CRCW06031K00FKEA
1	R <sub>OFF</sub>	23.2kΩ 1%	VISHAY	CRCW060323K2FKEA
1	R <sub>UV1</sub>	6.98kΩ 1%	VISHAY	CRCW06036K98FKEA
1	R <sub>UV2</sub>	49.9kΩ 1%	VISHAY	CRCW060349K9FKEA
1	R <sub>SNS</sub>	0.05Ω 1% 1W	VISHAY	WSL2512R0500FEA

\*U<sub>2</sub> could be replaced with a 500kΩ NTC thermistor connected from IADJ to GND.

**Physical Dimensions** inches (millimeters) unless otherwise noted

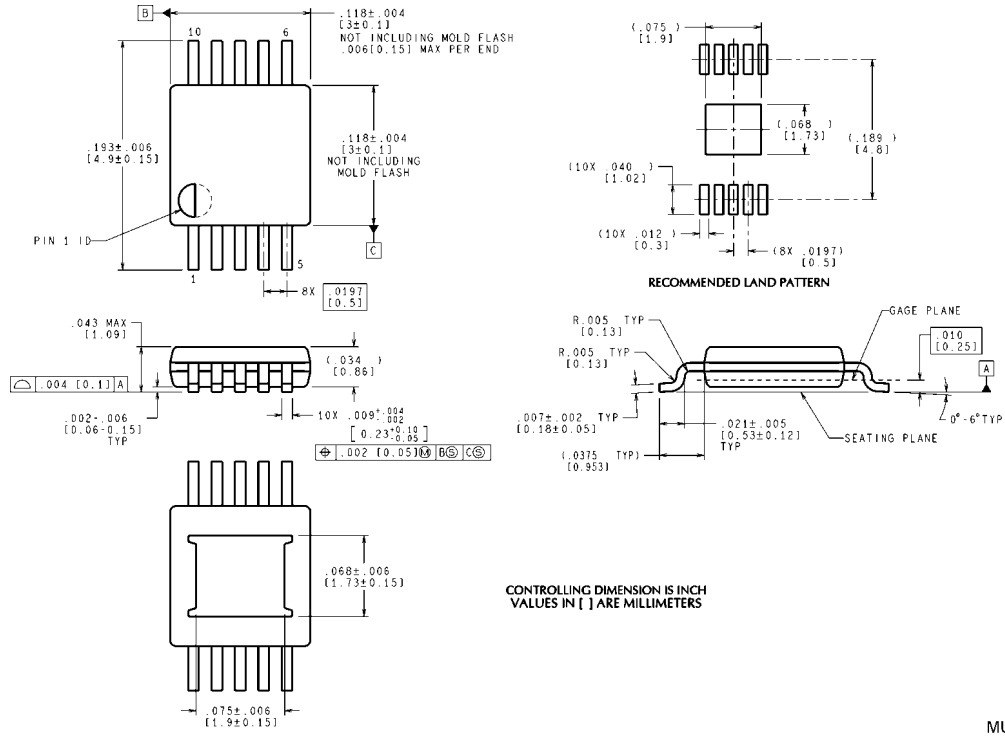

**10-Lead Exposed Pad Plastic eMSOP Package  
NS Package Number MUC10A**

MUC10A (Rev A)

## Notes

LM3409/LM3409HV

## Notes

For more National Semiconductor product information and proven design tools, visit the following Web sites at:

Products		Design Support	
Amplifiers	<a href="http://www.national.com/amplifiers">www.national.com/amplifiers</a>	WEBENCH® Tools	<a href="http://www.national.com/webench">www.national.com/webench</a>
Audio	<a href="http://www.national.com/audio">www.national.com/audio</a>	App Notes	<a href="http://www.national.com/appnotes">www.national.com/appnotes</a>
Clock and Timing	<a href="http://www.national.com/timing">www.national.com/timing</a>	Reference Designs	<a href="http://www.national.com/refdesigns">www.national.com/refdesigns</a>
Data Converters	<a href="http://www.national.com/adc">www.national.com/adc</a>	Samples	<a href="http://www.national.com/samples">www.national.com/samples</a>
Interface	<a href="http://www.national.com/interface">www.national.com/interface</a>	Eval Boards	<a href="http://www.national.com/evalboards">www.national.com/evalboards</a>
LVDS	<a href="http://www.national.com/lvds">www.national.com/lvds</a>	Packaging	<a href="http://www.national.com/packaging">www.national.com/packaging</a>
Power Management	<a href="http://www.national.com/power">www.national.com/power</a>	Green Compliance	<a href="http://www.national.com/quality/green">www.national.com/quality/green</a>
Switching Regulators	<a href="http://www.national.com/switchers">www.national.com/switchers</a>	Distributors	<a href="http://www.national.com/contacts">www.national.com/contacts</a>
LDOs	<a href="http://www.national.com/ldo">www.national.com/ldo</a>	Quality and Reliability	<a href="http://www.national.com/quality">www.national.com/quality</a>
LED Lighting	<a href="http://www.national.com/led">www.national.com/led</a>	Feedback/Support	<a href="http://www.national.com/feedback">www.national.com/feedback</a>
Voltage Reference	<a href="http://www.national.com/vref">www.national.com/vref</a>	Design Made Easy	<a href="http://www.national.com/easy">www.national.com/easy</a>
PowerWise® Solutions	<a href="http://www.national.com/powerwise">www.national.com/powerwise</a>	Solutions	<a href="http://www.national.com/solutions">www.national.com/solutions</a>
Serial Digital Interface (SDI)	<a href="http://www.national.com/sdi">www.national.com/sdi</a>	Mil/Aero	<a href="http://www.national.com/milaero">www.national.com/milaero</a>
Temperature Sensors	<a href="http://www.national.com/tempensors">www.national.com/tempensors</a>	SolarMagic™	<a href="http://www.national.com/solarmagic">www.national.com/solarmagic</a>
Wireless (PLL/VCO)	<a href="http://www.national.com/wireless">www.national.com/wireless</a>	PowerWise® Design University	<a href="http://www.national.com/training">www.national.com/training</a>

THE CONTENTS OF THIS DOCUMENT ARE PROVIDED IN CONNECTION WITH NATIONAL SEMICONDUCTOR CORPORATION ("NATIONAL") PRODUCTS. NATIONAL MAKES NO REPRESENTATIONS OR WARRANTIES WITH RESPECT TO THE ACCURACY OR COMPLETENESS OF THE CONTENTS OF THIS PUBLICATION AND RESERVES THE RIGHT TO MAKE CHANGES TO SPECIFICATIONS AND PRODUCT DESCRIPTIONS AT ANY TIME WITHOUT NOTICE. NO LICENSE, WHETHER EXPRESS, IMPLIED, ARISING BY ESTOPPEL OR OTHERWISE, TO ANY INTELLECTUAL PROPERTY RIGHTS IS GRANTED BY THIS DOCUMENT.

TESTING AND OTHER QUALITY CONTROLS ARE USED TO THE EXTENT NATIONAL DEEMS NECESSARY TO SUPPORT NATIONAL'S PRODUCT WARRANTY. EXCEPT WHERE MANDATED BY GOVERNMENT REQUIREMENTS, TESTING OF ALL PARAMETERS OF EACH PRODUCT IS NOT NECESSARILY PERFORMED. NATIONAL ASSUMES NO LIABILITY FOR APPLICATIONS ASSISTANCE OR BUYER PRODUCT DESIGN. BUYERS ARE RESPONSIBLE FOR THEIR PRODUCTS AND APPLICATIONS USING NATIONAL COMPONENTS. PRIOR TO USING OR DISTRIBUTING ANY PRODUCTS THAT INCLUDE NATIONAL COMPONENTS, BUYERS SHOULD PROVIDE ADEQUATE DESIGN, TESTING AND OPERATING SAFEGUARDS.

EXCEPT AS PROVIDED IN NATIONAL'S TERMS AND CONDITIONS OF SALE FOR SUCH PRODUCTS, NATIONAL ASSUMES NO LIABILITY WHATSOEVER, AND NATIONAL DISCLAIMS ANY EXPRESS OR IMPLIED WARRANTY RELATING TO THE SALE AND/OR USE OF NATIONAL PRODUCTS INCLUDING LIABILITY OR WARRANTIES RELATING TO FITNESS FOR A PARTICULAR PURPOSE, MERCHANTABILITY, OR INFRINGEMENT OF ANY PATENT, COPYRIGHT OR OTHER INTELLECTUAL PROPERTY RIGHT.

### LIFE SUPPORT POLICY

**NATIONAL'S PRODUCTS ARE NOT AUTHORIZED FOR USE AS CRITICAL COMPONENTS IN LIFE SUPPORT DEVICES OR SYSTEMS WITHOUT THE EXPRESS PRIOR WRITTEN APPROVAL OF THE CHIEF EXECUTIVE OFFICER AND GENERAL COUNSEL OF NATIONAL SEMICONDUCTOR CORPORATION.** As used herein:

Life support devices or systems are devices which (a) are intended for surgical implant into the body, or (b) support or sustain life and whose failure to perform when properly used in accordance with instructions for use provided in the labeling can be reasonably expected to result in a significant injury to the user. A critical component is any component in a life support device or system whose failure to perform can be reasonably expected to cause the failure of the life support device or system or to affect its safety or effectiveness.

National Semiconductor and the National Semiconductor logo are registered trademarks of National Semiconductor Corporation. All other brand or product names may be trademarks or registered trademarks of their respective holders.

Copyright© 2009 National Semiconductor Corporation

For the most current product information visit us at [www.national.com](http://www.national.com)



**National Semiconductor Americas Technical Support Center**  
 Email: [support@nsc.com](mailto:support@nsc.com)  
 Tel: 1-800-272-9959

**National Semiconductor Europe Technical Support Center**  
 Email: [europe.support@nsc.com](mailto:europe.support@nsc.com)

**National Semiconductor Asia Pacific Technical Support Center**  
 Email: [ap.support@nsc.com](mailto:ap.support@nsc.com)

**National Semiconductor Japan Technical Support Center**  
 Email: [jpn.feedback@nsc.com](mailto:jpn.feedback@nsc.com)