

LM136A-2.5/LM136-2.5QML Reference Diode

General Description

The LM136A-2.5/LM136-2.5 integrated circuit is a precision 2.5V shunt regulator diode. This monolithic IC voltage reference operates as a low-temperature-coefficient 2.5V zener with 0.2Ω dynamic impedance. A third terminal on the LM136-2.5 allows the reference voltage and temperature coefficient to be trimmed easily.

The LM136-2.5 is useful as a precision 2.5V low voltage reference for digital voltmeters, power supplies or op amp circuitry. The 2.5V make it convenient to obtain a stable reference from 5V logic supplies. Further, since the LM136-2.5 operates as a shunt regulator, it can be used as either a positive or negative voltage reference.

Features

- Available with radiation guarantee
— Total Ionizing Dose 100 krad(Si)
- Low temperature coefficient
- Wide operating current of 400 μA to 10 mA
- Guaranteed temperature stability
- Easily trimmed for minimum temperature drift
- Fast turn-on
- 3-lead transistor package

Ordering Information

NS Part Number	SMD Part Number	NS Package Number	Package Description
LM136H-2.5/883		H03H	T0-46, 3LD Metal Can
LM136AH-2.5-SMD	8418003XA	H03H	T0-46, 3LD Metal Can
LM136AH-2.5/883		H03H	T0-46, 3LD Metal Can
LM136AH-2.5RQV (Note 5)	5962R0050101VXA 100 krad(Si)	H03H	T0-46, 3LD Metal Can
LM136AH-2.5RLQV (Note 6)	5962R0050102VXA 100 krad(Si)	H03H	T0-46, 3LD Metal Can

Connection Diagram

TO-46
Metal Can Package

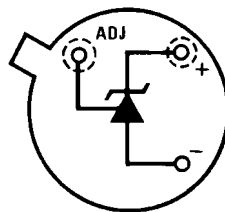

20139720

Bottom View
See NS Package Number H03H

Schematic Diagram

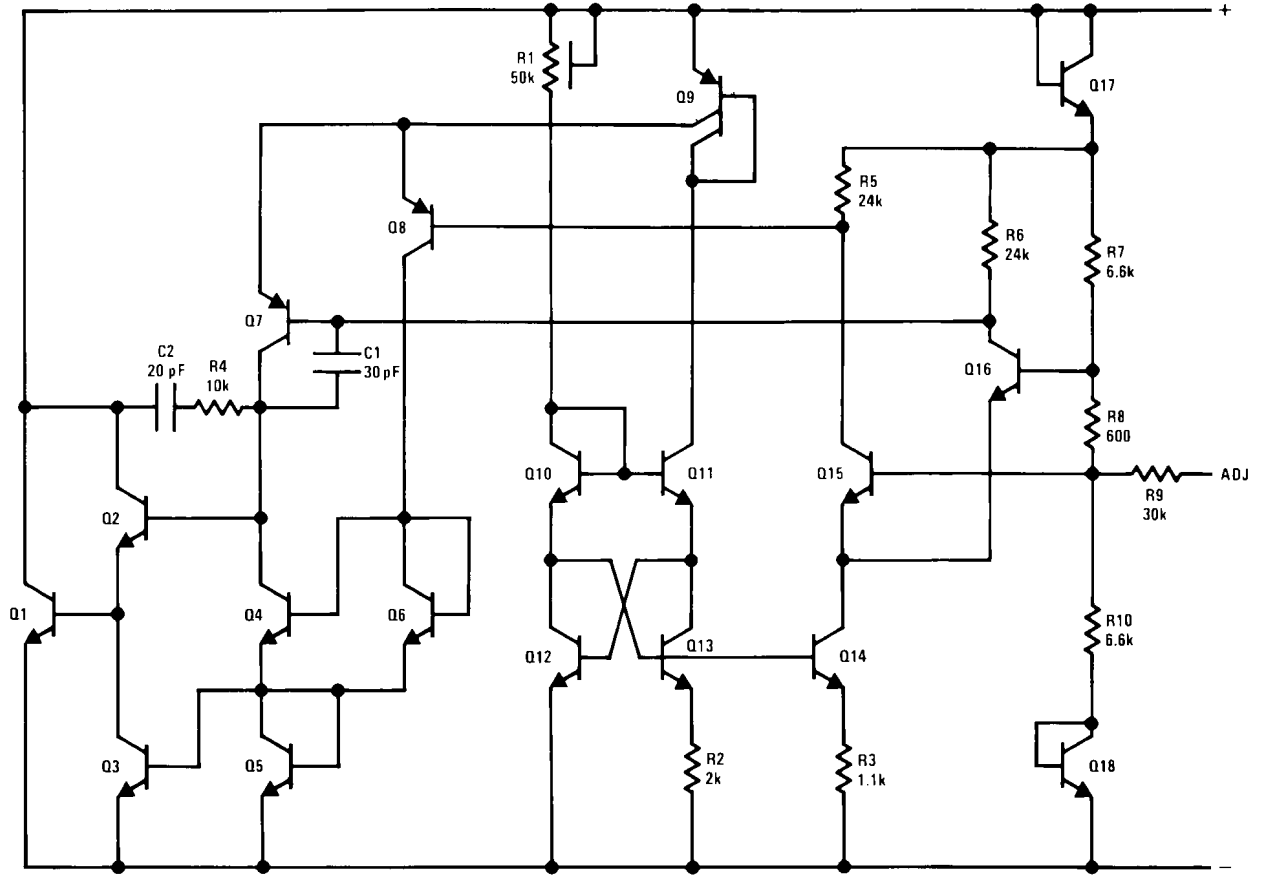

20139701

Typical Applications

2.5V Reference

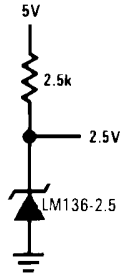

20139709

2.5V Reference with Minimum Temperature Coefficient

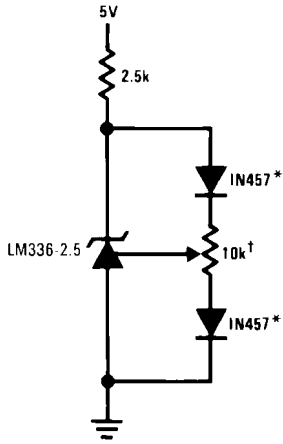

20139710

†Adjust to 2.490V

*Any silicon signal diode

Wide Input Range Reference

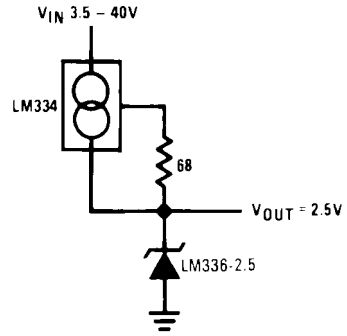

20139711

Absolute Maximum Ratings (Note 1)

Reverse Current	15 mA
Forward Current	10 mA
Storage Temperature	$-60^{\circ}\text{C} \leq T_A \leq +150^{\circ}\text{C}$
Operating Temperature Range (Note 2)	$-55^{\circ}\text{C} \leq T_A \leq +125^{\circ}\text{C}$
Maximum Junction Temperature (T_J)(Note 2)	+150°C
Lead Temperature (Soldering 10 seconds)	300°C
Thermal Resistance	
θ_{JA}	
Still Air Flow	354°C/W
500LF/Min Air Flow	77°C/W
θ_{JC}	46°C/W
ESD Rating (Note 3)	1,000V

Quality Conformance Inspection

Mil-Std-883, Method 5005 - Group A

Subgroup	Description	Temp°C
1	Static tests at	25
2	Static tests at	125
3	Static tests at	-55
4	Dynamic tests at	25
5	Dynamic tests at	125
6	Dynamic tests at	-55
7	Functional tests at	25
8A	Functional tests at	125
8B	Functional tests at	-55
9	Switching tests at	25
10	Switching tests at	125
11	Switching tests at	-55
12	Settling time at	25
13	Settling time at	125
14	Settling time at	-55

LM136-2.5 Electrical Characteristics**DC Parameters**The following conditions apply, unless otherwise specified. $I_R = 1\text{mA}$

Symbol	Parameter	Conditions	Notes	Min	Max	Unit	Sub-groups
I_{Adj}	Adjust Current	$V_{Adj} = 0.7\text{V}$		-125	+125	μA	1, 2, 3
ΔV_Z	Delta Zener Voltage	$0.4\text{mA} \leq I_Z \leq 10\text{mA}$			6.0	mV	1
					10	mV	2, 3
V_Z	Zener Voltage	$V_{Adj} = \text{Open}$		2.44	2.54	V	1
				2.42	2.56	V	2, 3
		$V_{Adj} = 0.7\text{V}$		2.39	2.49	V	1
				2.29	2.49	V	2, 3
$V_{Adj} = 1.9\text{V}$		2.49	2.69	V	1, 2, 3		
Z_{RD}	Reverse Dynamic Impedance		(Note 4)		1.0	Ω	1, 2, 3
V_{Stab}	Temperature Stability	$V_Z = \text{Adjusted to } 2.490\text{V}$			18	mV	2, 3

LM136A-2.5 Electrical Characteristics

DC Parameters

The following conditions apply, unless otherwise specified. $I_R = 1\text{ mA}$

Symbol	Parameter	Conditions	Notes	Min	Max	Unit	Sub-groups
I_{Adj}	Adjust Current	$V_{Adj} = 0.7\text{V}$		-125	+125	μA	1, 2, 3
ΔV_Z	Delta Zener Voltage	$0.4\text{mA} \leq I_Z \leq 10\text{ mA}$			6.0	mV	1
					10	mV	2, 3
V_Z	Zener Voltage	$V_{Adj} = \text{Open}$		2.465	2.515	V	1
				2.44	2.54	V	2, 3
		$V_{Adj} = 0.7\text{V}$		2.39	2.49	V	1
				2.29	2.49	V	2, 3
$V_{Adj} = 1.9\text{V}$		2.49	2.69	V	1, 2, 3		
Z_{RD}	Reverse Dynamic Impedance		(Note 4)		0.6	Ω	1
			(Note 4)		1.0	Ω	2, 3
V_{Stab}	Temperature Stability	$V_Z = \text{Adjusted to } 2.490\text{V}$			18	mV	2, 3

DC Drift Parameters

Delta calculations are performed on QMLV devices at Group B, Subgroup 5 only.

Symbol	Parameter	Conditions	Notes	Min	Max	Unit	Sub-groups
V_Z	Zener Voltage	$V_{Adj} = \text{Open}$		-10	+10	mV	1
		$V_{Adj} = 0.7\text{V}$		-10	+10	mV	1
		$V_{Adj} = 1.9\text{V}$		-10	+10	mV	1

Note 1: Absolute Maximum Ratings indicate limits beyond which damage to the device may occur. Operating Ratings indicate conditions for which the device is functional, but do not guarantee specific performance limits. For guaranteed specifications and test conditions, see the Electrical Characteristics. The guaranteed specifications apply only for the test conditions listed. Some performance characteristics may degrade when the device is not operated under the listed test conditions.

Note 2: The maximum power dissipation must be derated at elevated temperatures and is dictated by T_{Jmax} (maximum junction temperature), θ_{JA} (package junction to ambient thermal resistance), and T_A (ambient temperature). The maximum allowable power dissipation at any temperature is $P_{Dmax} = (T_{Jmax} - T_A) / \theta_{JA}$ or the number given in the Absolute Maximum Ratings, whichever is lower.

Note 3: Human body model, 1.5K Ω in series with 100pF.

Note 4: Parameter tested go-no-go only.

Note 5: Pre and post irradiation limits are identical to those listed under DC electrical characteristics. These parts may be dose rate sensitive in a space environment and may demonstrate enhanced low dose rate effect. Radiation end point limits for the noted parameters are guaranteed only for the conditions as specified in Mil-Std-883, Method 1019.

Note 6: Low dose rate testing has been performed on a wafer-by-wafer basis, per test method 1019 condition D of MIL-STD-883, with no enhanced low dose rate sensitivity (ELDRS) effect.

Typical Performance Characteristics

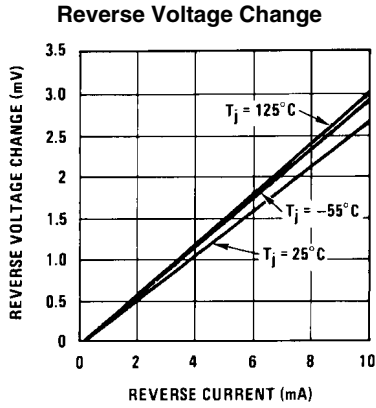

20139721

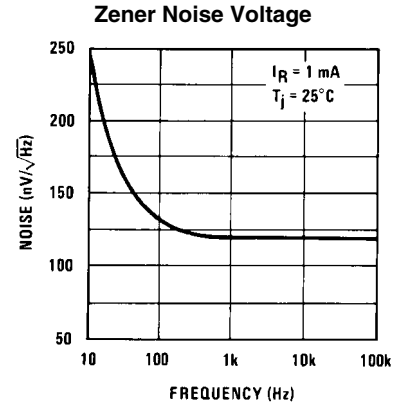

20139722

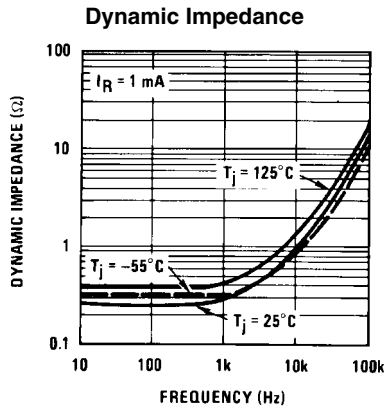

20139723

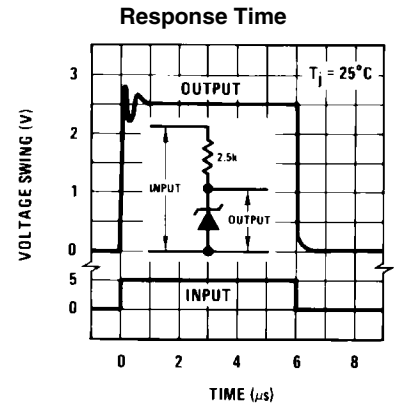

20139724

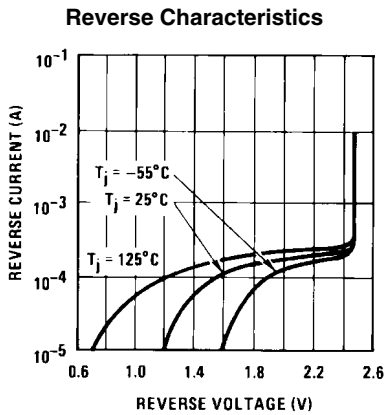

20139725

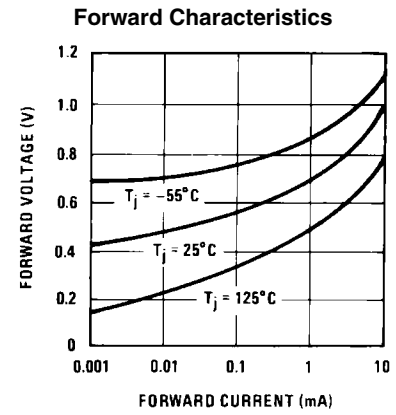

20139726

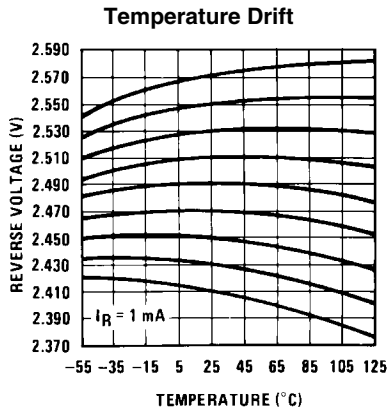

20139727

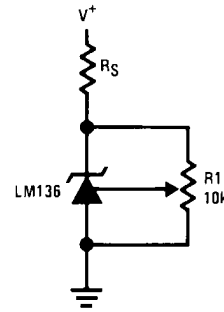

20139728

FIGURE 1. LM136 With Pot for Adjustment of Breakdown Voltage (Trim Range = ±120 mV typical)

Application Hints

The LM136 series voltage references are much easier to use than ordinary zener diodes. Their low impedance and wide operating current range simplify biasing in almost any circuit. Further, either the breakdown voltage or the temperature coefficient can be adjusted to optimize circuit performance.

Figure 1 shows an LM136 with a 10k potentiometer for adjusting the reverse breakdown voltage. With the addition of R1 the breakdown voltage can be adjusted without affecting the temperature coefficient of the device. The adjustment range is usually sufficient to adjust for both the initial device tolerance and inaccuracies in buffer circuitry.

If minimum temperature coefficient is desired, two diodes can be added in series with the adjustment potentiometer as shown in Figure 2. When the device is adjusted to 2.490V the temperature coefficient is minimized. Almost any silicon signal diode can be used for this purpose such as a 1N914, 1N4148 or a 1N457. For proper temperature compensation the diodes should be in the same thermal environment as the LM136. It is usually sufficient to mount the diodes near the LM136 on the printed circuit board. The absolute resistance of R1 is not critical and any value from 2k to 20k will work.

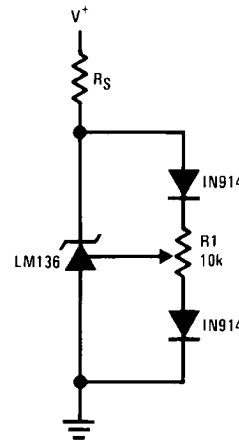

20139729

FIGURE 2. Temperature Coefficient Adjustment (Trim Range = ±70 mV typical)

Low Cost 2 Amp Switching Regulator†

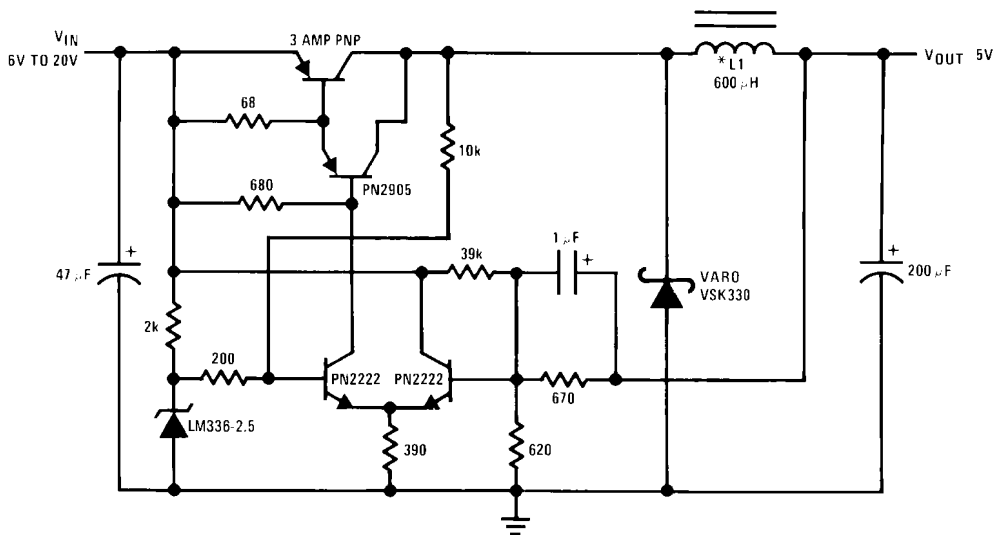

20139705

*L1 60 turns #16 wire on Arnold Core A-254168-2

†Efficiency ≈ 80%

Precision Power Regulator with Low Temperature Coefficient

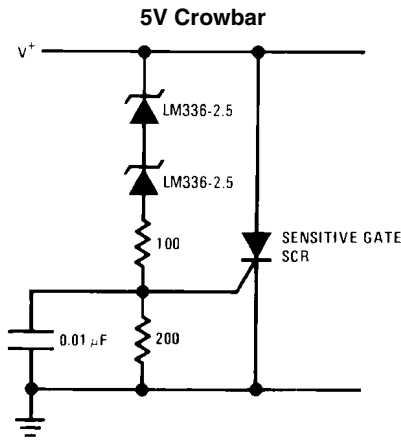
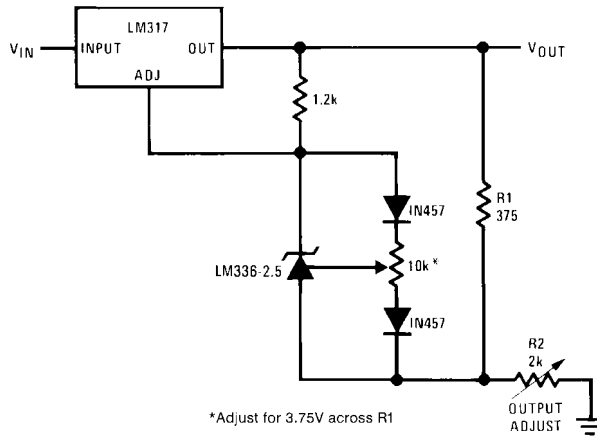

20139714

Trimmed 2.5V Reference with Temperature Coefficient Independent of Breakdown Voltage

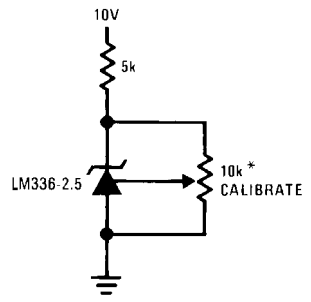

20139715

Adjustable Shunt Regulator

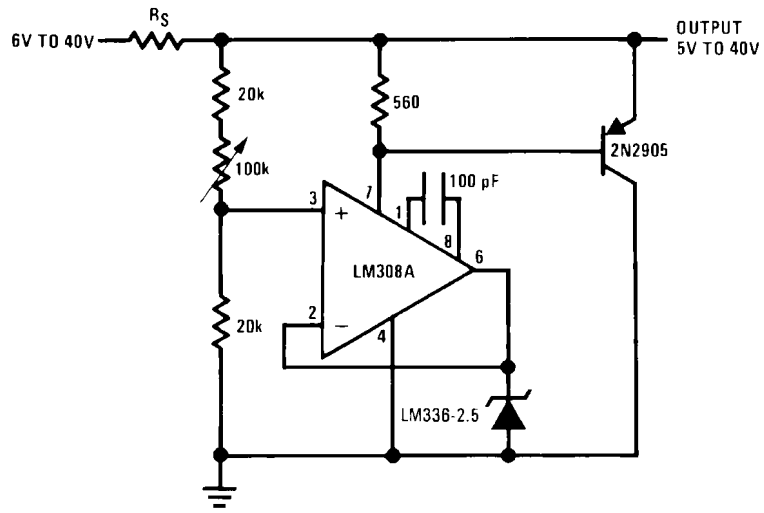

20139706

Linear Ohmmeter

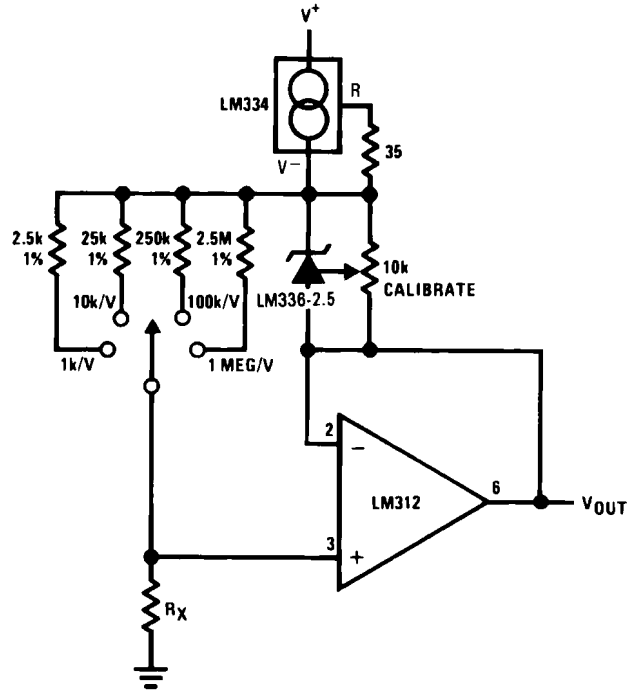

20139716

Op Amp with Output Clamped

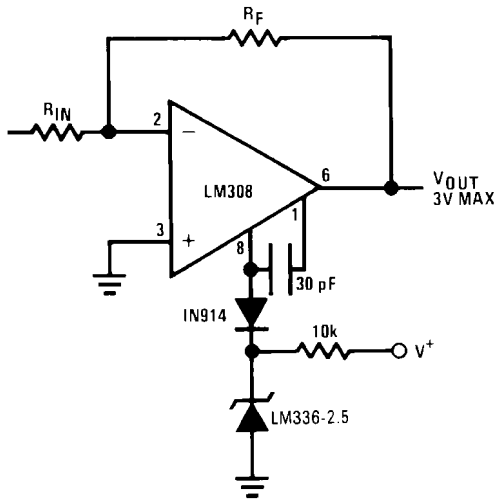

20139717

Bipolar Output Reference

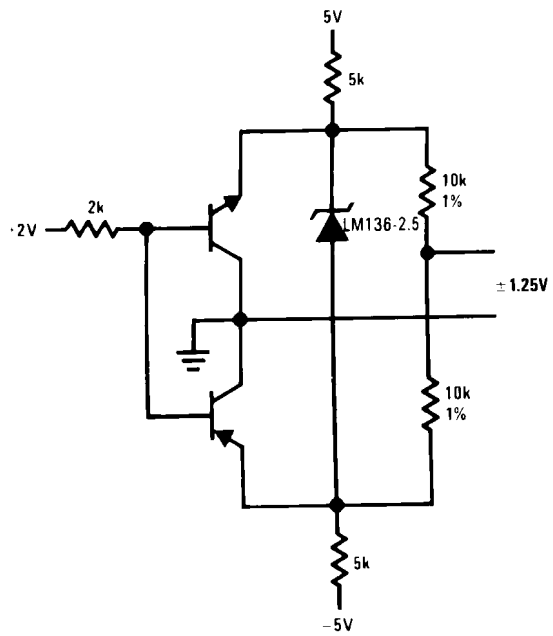

20139718

2.5V Square Wave Calibrator

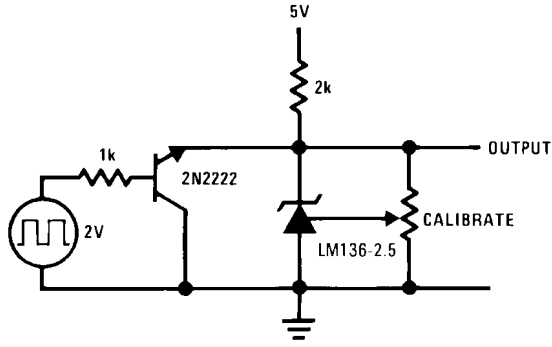

20139719

Low Noise Buffered Reference

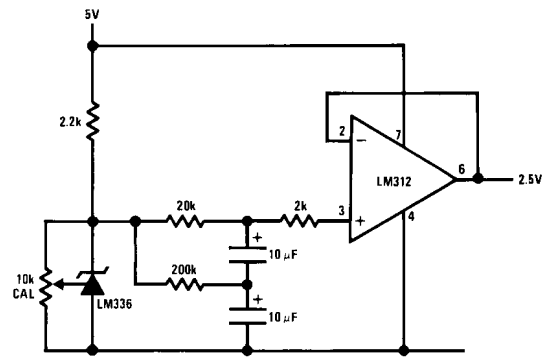

20139731

5V Buffered Reference

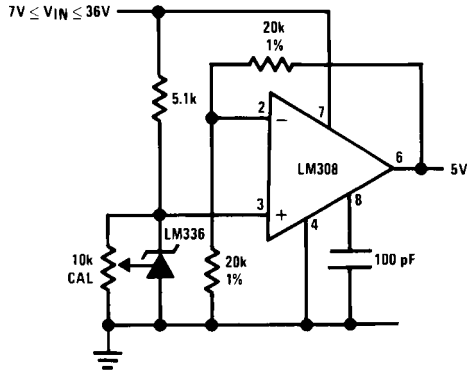

20139730

Revision History

Date Released	Revision	Section	Originator	Changes
07/06/07	A	New Release, Corporate format	L. Lytle	2 MDS datasheets converted into one corporate datasheet format. MNLM136-2.5-X Rev 0A0 and MNLM136A-2.5-X-RH. The ELDRS Part has also been added. Rev. 0E0 will be archived.

Physical Dimensions inches (millimeters) unless otherwise noted

For more National Semiconductor product information and proven design tools, visit the following Web sites at:

Products		Design Support	
Amplifiers	www.national.com/amplifiers	WEBENCH	www.national.com/webench
Audio	www.national.com/audio	Analog University	www.national.com/AU
Clock Conditioners	www.national.com/timing	App Notes	www.national.com/appnotes
Data Converters	www.national.com/adc	Distributors	www.national.com/contacts
Displays	www.national.com/displays	Green Compliance	www.national.com/quality/green
Ethernet	www.national.com/ethernet	Packaging	www.national.com/packaging
Interface	www.national.com/interface	Quality and Reliability	www.national.com/quality
LVDS	www.national.com/lvds	Reference Designs	www.national.com/refdesigns
Power Management	www.national.com/power	Feedback	www.national.com/feedback
Switching Regulators	www.national.com/switchers		H03H (Rev F)
LDOs	www.national.com/ldo		
LED Lighting	www.national.com/led		
PowerWise	www.national.com/powerwise		
Serial Digital Interface (SDI)	www.national.com/sdi		
Temperature Sensors	www.national.com/tempsensors		
Wireless (PLL/VCO)	www.national.com/wireless		

THE CONTENTS OF THIS DOCUMENT ARE PROVIDED IN CONNECTION WITH NATIONAL SEMICONDUCTOR CORPORATION ("NATIONAL") PRODUCTS. NATIONAL MAKES NO REPRESENTATIONS OR WARRANTIES WITH RESPECT TO THE ACCURACY OR COMPLETENESS OF THE CONTENTS OF THIS PUBLICATION AND RESERVES THE RIGHT TO MAKE CHANGES TO SPECIFICATIONS AND PRODUCT DESCRIPTIONS AT ANY TIME WITHOUT NOTICE. NO LICENSE, WHETHER EXPRESS, IMPLIED, ARISING BY ESTOPPEL OR OTHERWISE, TO ANY INTELLECTUAL PROPERTY RIGHTS IS GRANTED BY THIS DOCUMENT.

TESTING AND OTHER QUALITY CONTROLS ARE USED TO THE EXTENT NATIONAL DEEMS NECESSARY TO SUPPORT NATIONAL'S PRODUCT WARRANTY. EXCEPT WHERE MANDATED BY GOVERNMENT REQUIREMENTS, TESTING OF ALL PARAMETERS OF EACH PRODUCT IS NOT NECESSARILY PERFORMED. NATIONAL ASSUMES NO LIABILITY FOR APPLICATIONS ASSISTANCE OR BUYER PRODUCT DESIGN. BUYERS ARE RESPONSIBLE FOR THEIR PRODUCTS AND APPLICATIONS USING NATIONAL COMPONENTS. PRIOR TO USING OR DISTRIBUTING ANY PRODUCTS THAT INCLUDE NATIONAL COMPONENTS, BUYERS SHOULD PROVIDE ADEQUATE DESIGN, TESTING AND OPERATING SAFEGUARDS.

EXCEPT AS PROVIDED IN NATIONAL'S TERMS AND CONDITIONS OF SALE FOR SUCH PRODUCTS, NATIONAL ASSUMES NO LIABILITY WHATSOEVER, AND NATIONAL DISCLAIMS ANY EXPRESS OR IMPLIED WARRANTY RELATING TO THE SALE AND/OR USE OF NATIONAL PRODUCTS INCLUDING LIABILITY OR WARRANTIES RELATING TO FITNESS FOR A PARTICULAR PURPOSE, MERCHANTABILITY, OR INFRINGEMENT OF ANY PATENT, COPYRIGHT OR OTHER INTELLECTUAL PROPERTY RIGHT.

LIFE SUPPORT POLICY

NATIONAL'S PRODUCTS ARE NOT AUTHORIZED FOR USE AS CRITICAL COMPONENTS IN LIFE SUPPORT DEVICES OR SYSTEMS WITHOUT THE EXPRESS PRIOR WRITTEN APPROVAL OF THE CHIEF EXECUTIVE OFFICER AND GENERAL COUNSEL OF NATIONAL SEMICONDUCTOR CORPORATION. As used herein:

Life support devices or systems are devices which (a) are intended for surgical implant into the body, or (b) support or sustain life and whose failure to perform when properly used in accordance with instructions for use provided in the labeling can be reasonably expected to result in a significant injury to the user. A critical component is any component in a life support device or system whose failure to perform can be reasonably expected to cause the failure of the life support device or system or to affect its safety or effectiveness.

National Semiconductor and the National Semiconductor logo are registered trademarks of National Semiconductor Corporation. All other brand or product names may be trademarks or registered trademarks of their respective holders.

Copyright© 2007 National Semiconductor Corporation

For the most current product information visit us at www.national.com



National Semiconductor Americas Customer Support Center
 Email: new.feedback@nsc.com
 Tel: 1-800-272-9959

National Semiconductor Europe Customer Support Center
 Fax: +49 (0) 180-530-85-86
 Email: europe.support@nsc.com
 Deutsch Tel: +49 (0) 69 9508 6208
 English Tel: +49 (0) 870 24 0 2171
 Français Tel: +33 (0) 1 41 91 8790

National Semiconductor Asia Pacific Customer Support Center
 Email: ap.support@nsc.com

National Semiconductor Japan Customer Support Center
 Fax: 81-3-5639-7507
 Email: jpn.feedback@nsc.com
 Tel: 81-3-5639-7560