

# MTB001

### FEATURES

- Four output driver per package
- TTL/CMOS compatible inputs (Low active)

### APPLICATION

- Head needle drive for printer
- Stepping motor drive for office automation products

### RATINGS

#### ● Absolute Maximum Ratings (Ta=25°C)

Item	Symbol	Ratings	Unit
Output Voltage	$V_{CEO(SUS)}$	80	V
Output Current	$I_O$	4	A
Reverse Voltage(flyback diode)	$V_R$	80	V
Forward Current(each flyback diode)	$I_F$	4	A
Forward Current(each common terminal)	$I_F$	18	A
Output Current(each GND terminal)	$I_{GND}$	10	A
Logic Supply Voltage	$V_{CC}$	0~7	V
Logic Input Voltage	$V_{IN}$	0~ $V_{CC}$	V
Enable Input Voltage	$V_{ENA}$	0~ $V_{CC}$	V
Total Power Dissipation	$P_T$	5	W
Junction Temperature	$T_j$	150	°C
Storage Temperature	$T_{stg}$	-40~150	°C

#### ● Electrical Characteristics (Ta=25°C)

Item	Symbol	Test Conditions	min.	typ.	max.	Unit
Output Saturation Voltage	$V_{CE(sat)}$	$V_{CC}=5V, I_c=3A, V_{IN}=V_{ENA}=0V$		1.3	1.7	V
Output Leakage Current	$I_{CE}$	$V_{CE}=80V$			10	$\mu A$
Output Sustaining Voltage	$V_{CEO(sus)}$	$I_c=0.4A$	80			V
Logic Supply Current(Standby)	$I_{CC(OFF)}$	$V_{CC}=5V, V_{IN}="H"$		15		mA
Logic Supply Current(All Circuit ON)	$I_{CC(ON)}$	$V_{CC}=5V, V_{IN}="L"$		55		mA
Input High Voltage	$V_{INH}$	$V_{CC}=5V$	2.7			V
Input Low Voltage	$V_{INL}$	$V_{CC}=5V$			1.5	V
Logic Low Input Current	$I_{INL}$	$V_{CC}=5V, V_{IN}=0V$		-10	-50	$\mu A$
Enable"H"Input Voltage	$V_{ENAH}$	$V_{CC}=5V$	2.7			V
Enable"L"Input Voltage	$V_{ENAL}$	$V_{CC}=5V$			1.5	V
Enable"L"Input Current	$I_{ENAL}$	$V_{CC}=5V, V_{ENA}=0V$		-10	-150	$\mu A$
Thermal Resistance	$\theta_{jc}$				3.57	°C/W
	$\theta_{ja}$				25	
Reverse Current(each flyback diode)	$I_R$	$V_R=80V$			10	$\mu A$
Reverse Voltage(flyback diode)	$V_F$	$I_F=3A$		1.5	1.7	V
Dielectric Strength	$V_{ISO}$	Substrate to Terminals	500			V

### OUTLINE DIMENSIONS

Case : SIP-16

(Unit : mm)

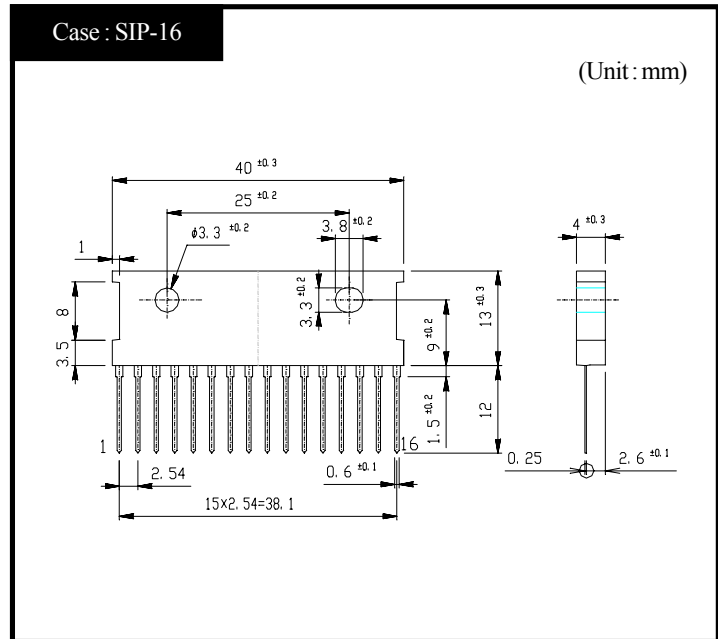

## ● Equivalent Circuit

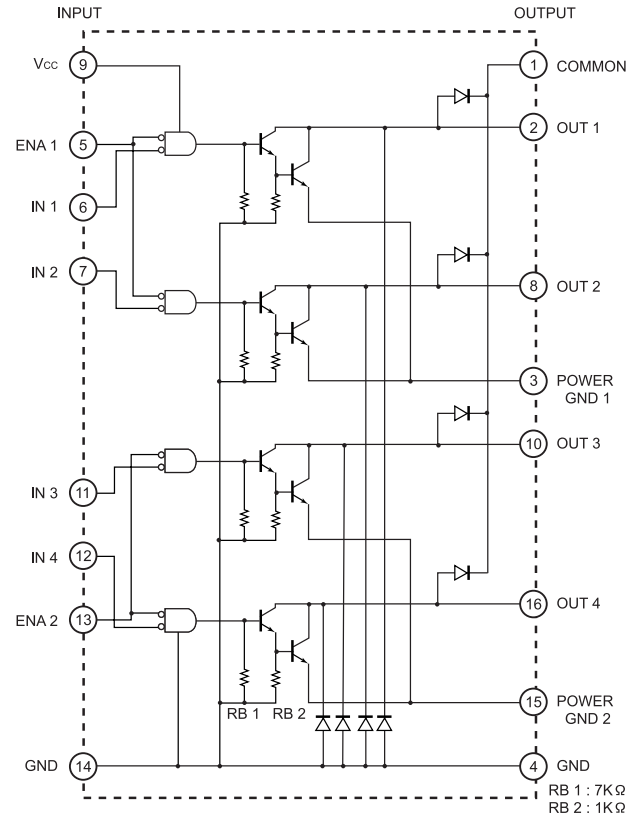

Note) Please connect the terminal 4 and 14 to the GND.

## ● Pin Assignment

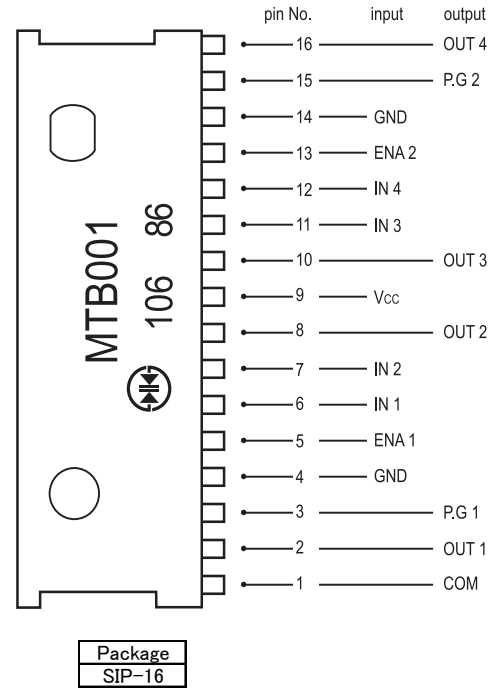

## ● True Table

V <sub>CC</sub>	V <sub>IN</sub>	V <sub>ENA</sub>	Output Transistor
L	X	X	OFF
H	H	H	OFF
H	H	L	OFF
H	L	H	OFF
H	L	L	ON

## ● Recommended Operating Conditions (Ta=25°C)

Item	Symbol	min.	typ.	max.	Unit
Supply Voltage	V <sub>CC</sub>	4.5	5.0	5.5	V
Output Current	I <sub>C</sub> I <sub>F</sub>			3	A
Output Voltage	V <sub>CE</sub> V <sub>R</sub>			70	V
Sensing Voltage	V <sub>S</sub>			1.0	V
Junction Temperature	T <sub>j</sub>	-25		120	°C