

General Description

The MIC2025 and MIC2075 are high-side MOSFET switches optimized for general-purpose power distribution requiring circuit protection.

The MIC2025/75 are internally current limited and have thermal shutdown that protects the device and load. The MIC2075 offers “smart” thermal shutdown that reduces current consumption in fault modes. When a thermal shutdown fault occurs, the output is latched off until the faulty load is removed. Removing the load or toggling the enable input will reset the device output.

Both devices employ soft-start circuitry that minimizes inrush current in applications where highly capacitive loads are employed. A fault status output flag is provided that is asserted during overcurrent and thermal shutdown conditions.

The MIC2025/75 is available in the MM8™ 8-lead MSOP and 8-lead SOP.

Features

- 140mΩ maximum on-resistance
- 2.7V to 5.5V operating range
- 500mA minimum continuous output current
- Short-circuit protection with thermal shutdown
- Fault status flag with 3ms filter eliminates false assertions
- Undervoltage lockout
- Reverse current flow blocking (no “body diode”)
- Circuit breaker mode (MIC2075) reduces power consumption
- Logic-compatible input
- Soft-start circuit
- Low quiescent current
- Pin-compatible with MIC2525

Applications

- USB peripherals
- General purpose power switching
- ACPI power distribution
- Notebook PCs
- PDAs
- PC card hot swap

Typical Application

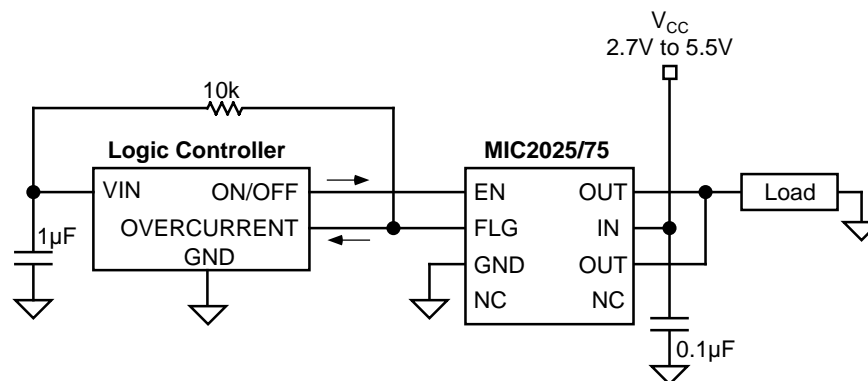

Ordering Information

Part Number	Enable	Temperature Range	Package
MIC2025-1BM	Active High	-40°C to +85°C	8-lead SOP
MIC2025-2BM	Active Low	-40°C to +85°C	8-lead SOP
MIC2025-1BMM	Active High	-40°C to +85°C	8-lead MSOP
MIC2025-2BMM	Active Low	-40°C to +85°C	8-lead MSOP
MIC2075-1BM	Active High	-40°C to +85°C	8-lead SOP
MIC2075-2BM	Active Low	-40°C to +85°C	8-lead SOP
MIC2075-1BMM	Active High	-40°C to +85°C	8-lead MSOP
MIC2075-2BMM	Active Low	-40°C to +85°C	8-lead MSOP

Pin Configuration

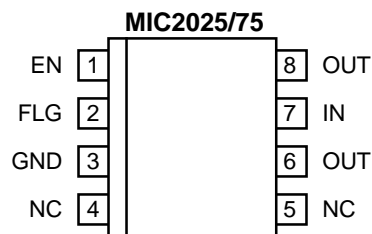

8-Lead SOP (BM)
8-Lead MSOP (BMM)

Pin Description

Pin Number	Pin Name	Pin Function
1	EN	Switch Enable (Input): Active-high (-1) or active-low (-2).
2	FLG	Fault Flag (Output): Active-low, open-drain output. Indicates overcurrent or thermal shutdown conditions. Overcurrent condition must exceed t_D in order to assert FLG.
3	GND	Ground
4	NC	not internally connected
5	NC	not internally connected
6, 8	OUT	Supply (Output): Pins must be connected together.
7	IN	Supply Voltage (Input).

Absolute Maximum Ratings (Note 1)

Supply Voltage (V_{IN})	–0.3V to 6V
Fault Flag Voltage (V_{FLG})	+6V
Fault Flag Current (I_{FLG})	25mA
Output Voltage (V_{OUT})	+6V
Output Current (I_{OUT})	Internally Limited
Enable Input (I_{EN})	–0.3V to $V_{IN} + 3V$
Storage Temperature (T_S)	–65°C to +150°C

ESD Rating, **Note 3**

Operating Ratings (Note 2)

Supply Voltage (V_{IN})	+2.7V to +5.5V
Ambient Temperature (T_A)	–40°C to +85°C
Junction Temperature (T_J)	Internally Limited
Thermal Resistance	
SOP (θ_{JA})	160°C/W
MSOP(θ_{JA})	206°C/W

Electrical Characteristics

$V_{IN} = +5V$; $T_A = 25^\circ C$, **bold** values indicate $-40^\circ C \leq T_A \leq +85^\circ C$; unless noted

Symbol	Parameter	Condition	Min	Typ	Max	Units	
I_{DD}	Supply Current	MIC20x5-1, $V_{EN} \leq 0.8V$, (switch off), OUT = open		0.75	5	μA	
		MIC20x5-2, $V_{EN} \geq 2.4V$, (switch off), OUT = open		0.75	5	μA	
		MIC20x5-1, $V_{EN} \geq 2.4V$, (switch on), OUT = open				160	μA
		MIC20x5-2, $V_{EN} \leq 0.8V$, (switch on), OUT = open				160	μA
V_{EN}	Enable Input Voltage	low-to-high transition		2.1	2.4	V	
		high-to-low transition	0.8	1.9		V	
	Enable Input Hysteresis			200		mV	
I_{EN}	Enable Input Current	$V_{EN} = 0V$ to 5.5V	–1	0.01	1	μA	
		Control Input Capacitance		1		pF	
$R_{DS(on)}$	Switch Resistance	$V_{IN} = 5V$, $I_{OUT} = 500mA$		90	140	m Ω	
		$V_{IN} = 3.3V$, $I_{OUT} = 500mA$		100	160	m Ω	
	Output Leakage Current	MIC2025/2075 (output off)			10	μA	
		OFF Current in Latched Thermal Shutdown	MIC2075 (during thermal shutdown state)		50		μA
t_{ON}	Output Turn-On Delay	$R_L = 10\Omega$, $C_L = 1\mu F$, see “Timing Diagrams”	1	2.5	6	ms	
t_R	Output Turn-On Rise Time	$R_L = 10\Omega$, $C_L = 1\mu F$, see “Timing Diagrams”	0.5	2.3	5.9	ms	
t_{OFF}	Output Turnoff Delay	$R_L = 10\Omega$, $C_L = 1\mu F$, see “Timing Diagrams”		50	100	μs	
t_F	Output Turnoff Fall Time	$R_L = 10\Omega$, $C_L = 1\mu F$, see “Timing Diagrams”		50	100	μs	
I_{LIMIT}	Short-Circuit Output Current	$V_{OUT} = 0V$, enabled into short-circuit.	0.5	0.7	1.25	A	
		Current-Limit Threshold	ramped load applied to output, Note 4		0.85	1.25	A
	Short-Circuit Response Time	$V_{OUT} = 0V$ to $I_{OUT} = I_{LIMIT}$ (Short applied to output)		24		μs	
t_D	Overcurrent Flag Response Delay	$V_{IN} = 5V$, apply $V_{OUT} = 0V$ until FLG low	1.5	3	7	ms	
		$V_{IN} = 3.3V$, apply $V_{OUT} = 0V$ until FLG low	1.5	3	8	ms	
	Undervoltage Lockout Threshold	V_{IN} rising	2.2	2.5	2.7	V	
		V_{IN} falling	2.0	2.3	2.5	V	

Symbol	Parameter	Condition	Min	Typ	Max	Units
	Error Flag Output Resistance	$I_L = 10\text{mA}, V_{IN} = 5\text{V}$		8	25	Ω
		$I_L = 10\text{mA}, V_{IN} = 3.3\text{V}$		11	40	Ω
	Error Flag Off Current	$V_{FLAG} = 5\text{V}$			10	μA
	Overtemperature Threshold	T_J increasing		140		$^{\circ}\text{C}$
		T_J decreasing		120		$^{\circ}\text{C}$

- Note 1.** Exceeding the absolute maximum rating may damage the device.
- Note 2.** The device is not guaranteed to function outside its operating rating.
- Note 3.** Devices are ESD sensitive. Handling precautions recommended.
- Note 4.** See "Functional Characteristics: Current-Limit Response" graph.

Test Circuit

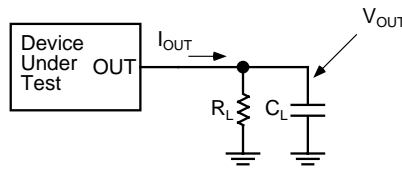

Timing Diagrams

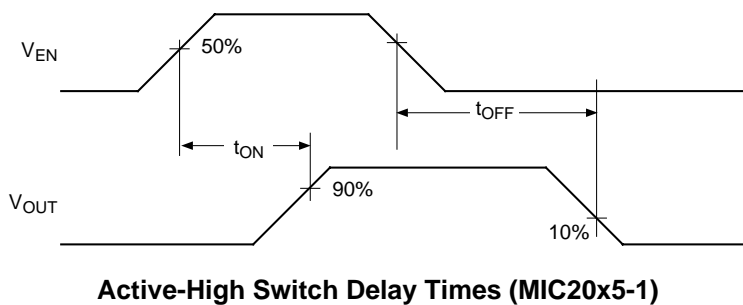
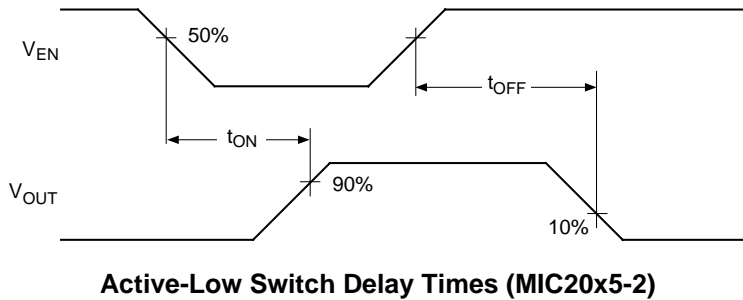
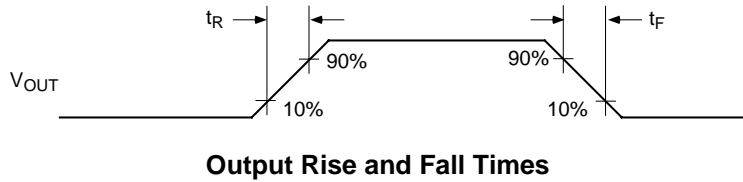

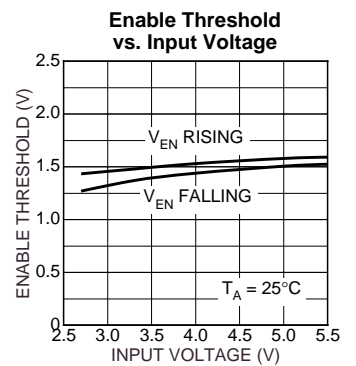
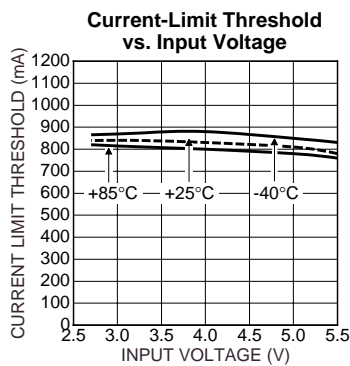
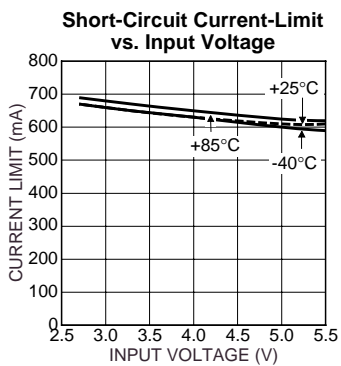
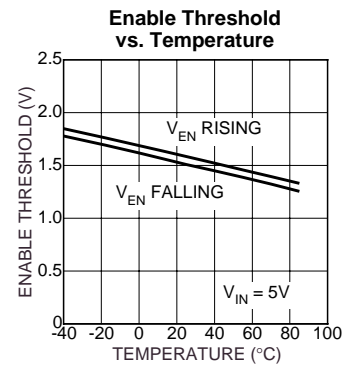
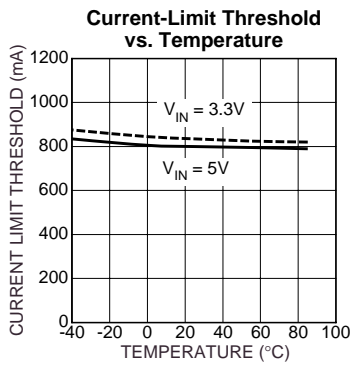
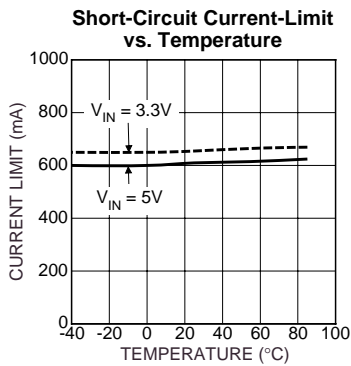
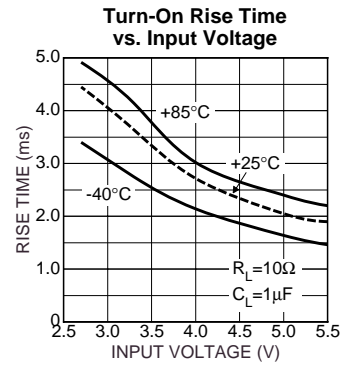
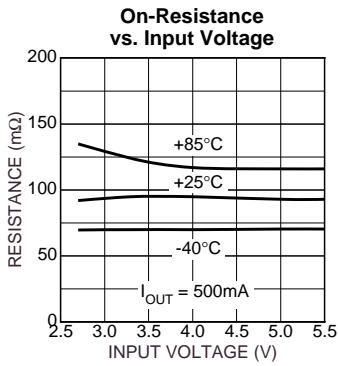
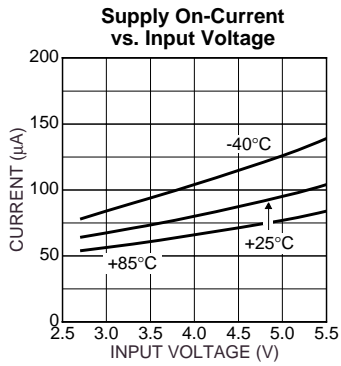
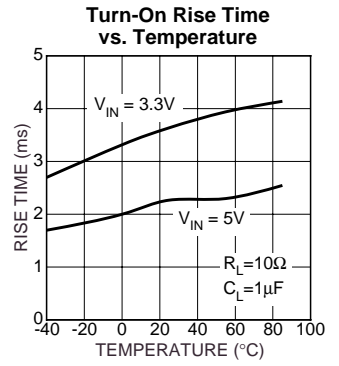
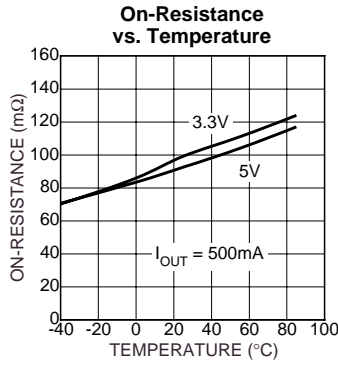
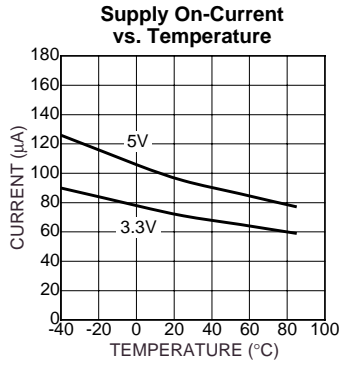

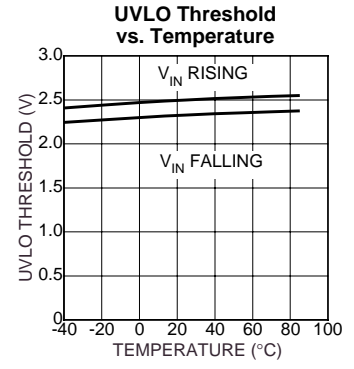
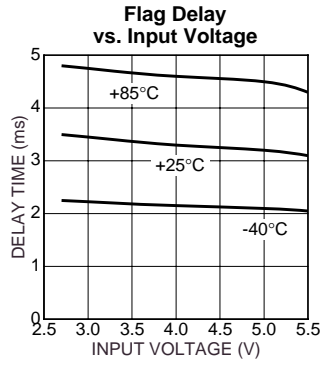
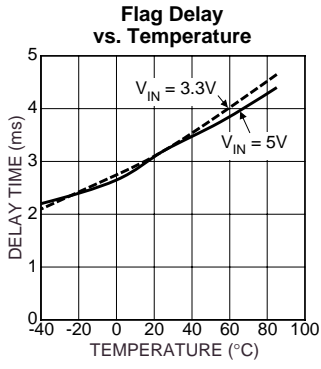

Functional Characteristics

UVLO— V_{IN} Rising (MIC2025-1)

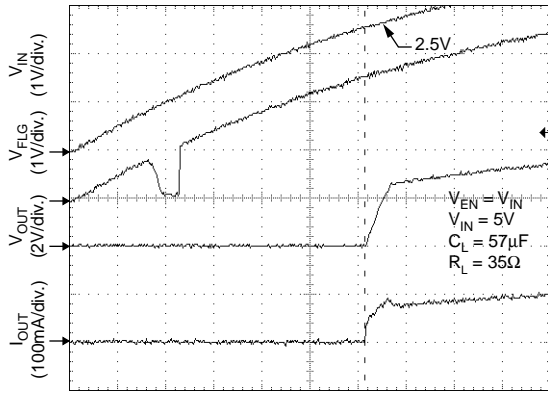

TIME (10ms/div.)

UVLO— V_{IN} Falling (MIC2025-1)

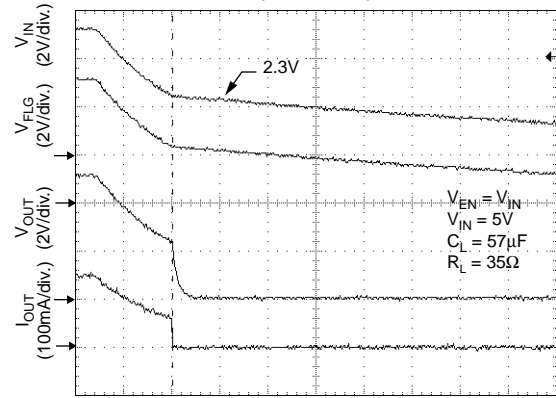

TIME (25ms/div.)

Turn-On Response (MIC2025-1)

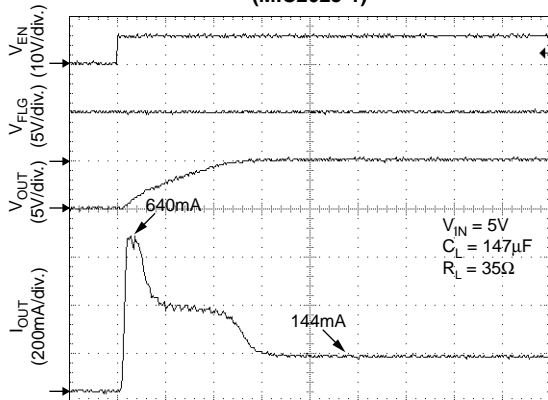

TIME (1ms/div.)

Turnoff Response (MIC2025-1)

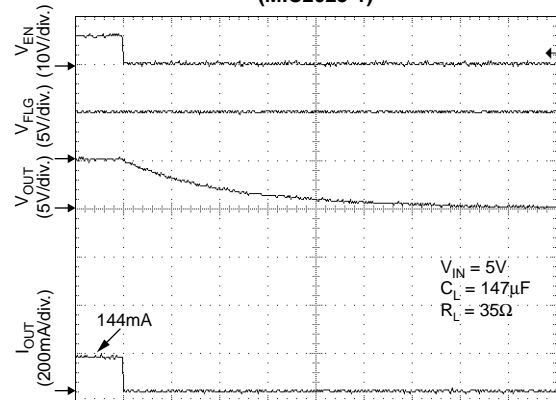

TIME (2.5ms/div.)

Inrush Current Response (MIC2025-1)

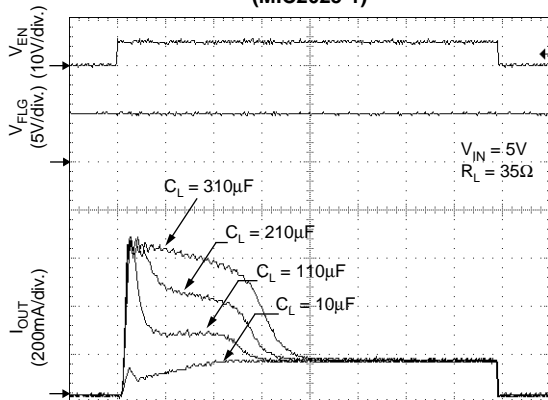

TIME (1ms/div.)

Enable Into Short (MIC2025-1)

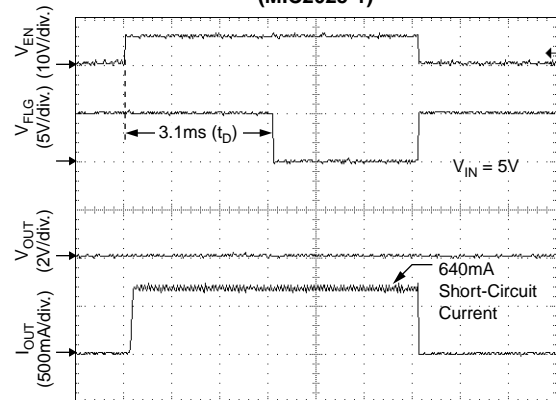

TIME (1ms/div.)

**Current-Limit Response
(Ramped Load Into Short—MIC2025-1)**

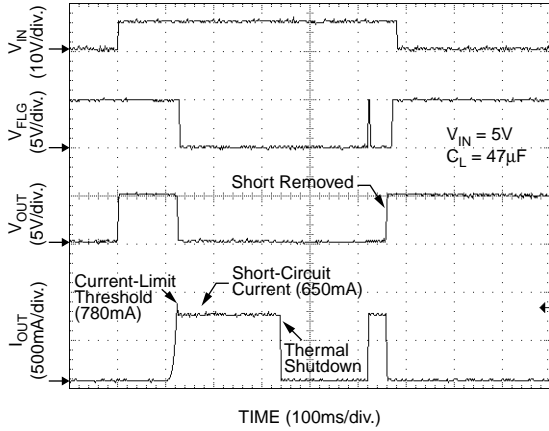

**Current-Limit Transient Response
(Enable Into Short—MIC2025-1)**

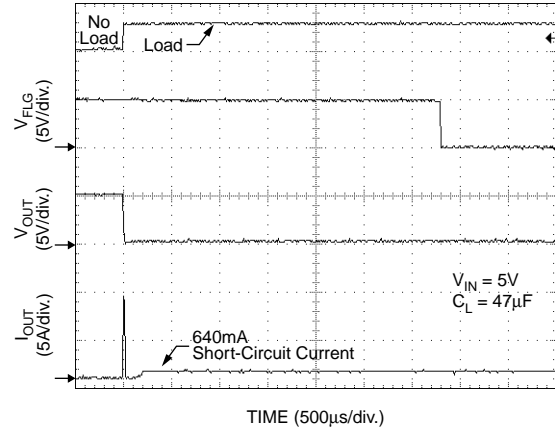

**Current-Limit Transient Response
(MIC2025-1)**

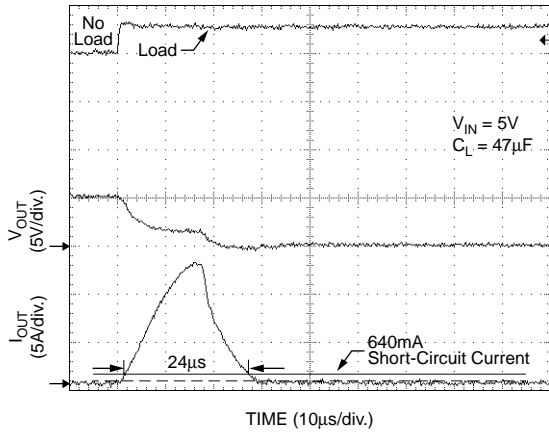

**Thermal Shutdown Response
(Output Reset by Removing Load—MIC2075-1)**

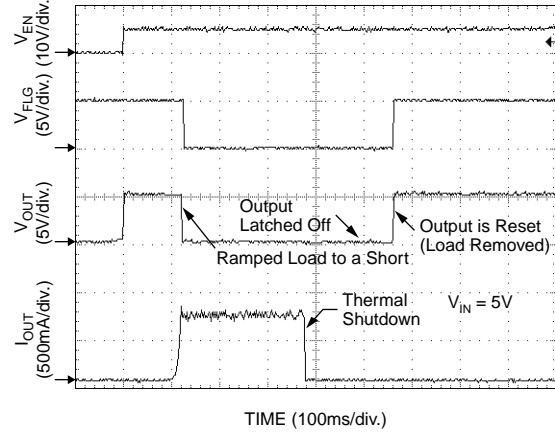

**Thermal Shutdown
(Output Reset by Toggling Enable—MIC2075-1)**

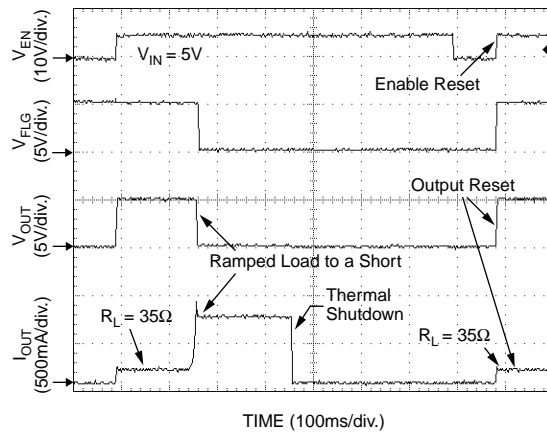

Block Diagram

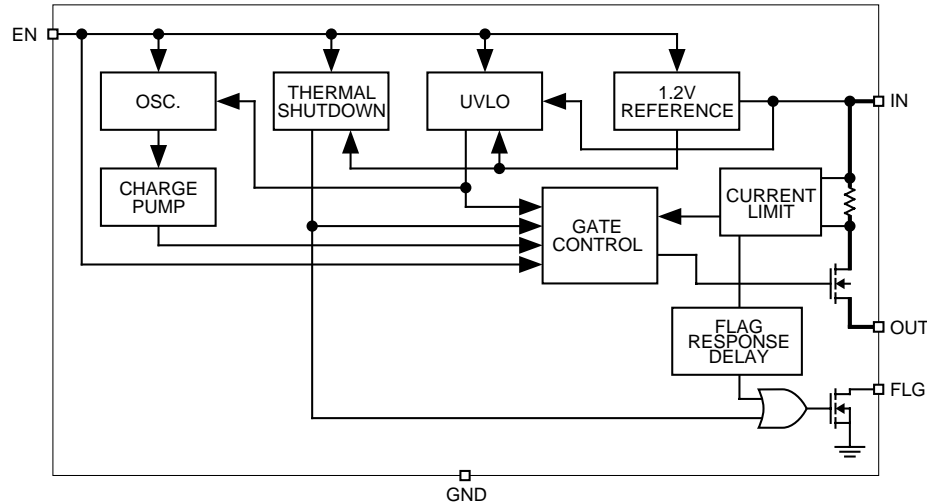

Functional Description

Input and Output

IN is the power supply connection to the logic circuitry and the drain of the output MOSFET. OUT is the source of the output MOSFET. In a typical circuit, current flows from IN to OUT toward the load. If V_{OUT} is greater than V_{IN} , current will flow from OUT to IN since the switch is bidirectional when enabled. The output MOSFET and driver circuitry are also designed to allow the MOSFET source to be externally forced to a higher voltage than the drain ($V_{OUT} > V_{IN}$) when the switch is disabled. In this situation, the MIC2025/75 avoids undesirable current flow from OUT to IN.

Thermal Shutdown

Thermal shutdown is employed to protect the device from damage should the die temperature exceed safe margins due mainly to short circuit faults. Each channel employs its own thermal sensor. Thermal shutdown shuts off the output MOSFET and asserts the FLG output if the die temperature reaches 140°C. The MIC2025 will automatically reset its output should the die temperature cool down to 120°C. The MIC2025 output and FLG signal will continue to cycle on and off until the device is disabled or the fault is removed. Figure 2 depicts typical timing. If the MIC2075 goes into thermal shutdown, its output will latch off and a pull-up current source is activated. This allows the output latch to automatically reset when the load (such as a USB device) is removed. The output can also be reset by toggling EN. Refer to Figure 1 for details.

Depending on PCB layout, package, ambient temperature, etc., it may take several hundred milliseconds from the incidence of the fault to the output MOSFET being shut off. The worst-case scenario of thermal shutdown is that of a short-circuit fault and is shown in the in the "Function Characteristics: Thermal Shutdown Response" graph.

Power Dissipation

The device's junction temperature depends on several factors such as the load, PCB layout, ambient temperature and package type. Equations that can be used to calculate power dissipation of each channel and junction temperature are found below.

$$P_D = R_{DS(on)} \times I_{OUT}^2$$

Total power dissipation of the device will be the summation of P_D for both channels. To relate this to junction temperature, the following equation can be used:

$$T_J = P_D \times \theta_{JA} + T_A$$

where:

T_J = junction temperature

T_A = ambient temperature

θ_{JA} = is the thermal resistance of the package

Current Sensing and Limiting

The current-limit threshold is preset internally. The preset level prevents damage to the device and external load but still allows a minimum current of 500mA to be delivered to the load.

The current-limit circuit senses a portion of the output MOSFET switch current. The current-sense resistor shown in the block diagram is virtual and has no voltage drop. The reaction to an overcurrent condition varies with three scenarios:

Switch Enabled into Short-Circuit

If a switch is enabled into a heavy load or short-circuit, the switch immediately enters into a constant-current mode, reducing the output voltage. The FLG signal is asserted indicating an overcurrent condition. See the Short-Circuit Response graph under Functional Characteristics.

Short-Circuit Applied to Enabled Output

When a heavy load or short-circuit is applied, a large transient current may flow until the current-limit circuitry responds. Once this occurs the device limits current to less than the short-circuit current limit specification. See the Short-Circuit Transient Response graph under Functional Characteristics.

Current-Limit Response—Ramped Load

The MIC2025/75 current-limit profile exhibits a small foldback effect of about 200mA. Once this current-limit threshold is exceeded the device switches into a constant current mode. It is important to note that the device will supply current until the current-limit threshold is exceeded. See the Current-Limit Response graph under Functional Characteristics.

Fault Flag

The FLG signal is an N-channel open-drain MOSFET output. FLG is asserted (active-low) when either an overcurrent or thermal shutdown condition occurs. In the case where an overcurrent condition occurs, FLG will be asserted only after the flag response delay time, t_D , has elapsed. This ensures that FLG is asserted only upon valid overcurrent conditions and that erroneous error reporting is eliminated. For example, false overcurrent conditions can occur during hot-plug events when a highly capacitive load is connected and causes a high transient inrush current that exceeds the current-limit threshold. The FLG response delay time t_D is typically 3ms.

Undervoltage Lockout

Undervoltage lockout (UVLO) prevents the output MOSFET from turning on until V_{IN} exceeds approximately 2.5V. Undervoltage detection functions only when the switch is enabled.

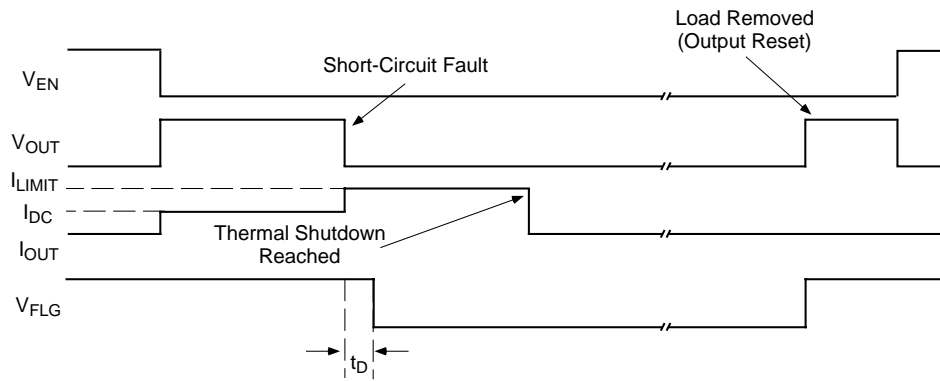

Figure 1. MIC2075-2 Timing: Output Reset by Removing Load

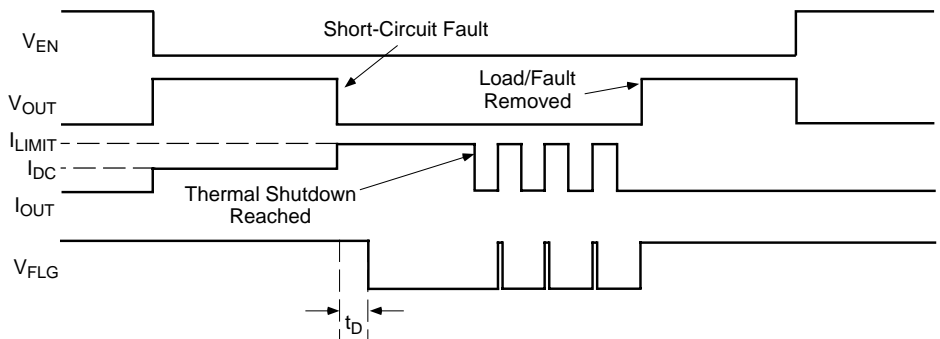

Figure 2. MIC2025-2 Timing

Applications Information

Supply Filtering

A 0.1 μ F to 1 μ F bypass capacitor positioned close to V_{IN} and GND of the device is strongly recommended to control supply transients. Without a bypass capacitor, an output short may cause sufficient ringing on the input (from supply lead inductance) to damage internal control circuitry.

Printed Circuit Board Hot-Plug

The MIC2025/75 are ideal inrush current-limiters suitable for hot-plug applications. Due to the integrated charge pump, the MIC2025/75 presents a high impedance when off and slowly becomes a low impedance as it turns on. This “soft-start” feature effectively isolates power supplies from highly capacitive loads by reducing inrush current during hot-plug events. Figure 3 shows how the MIC2075 may be used in a hot-plug application.

In cases of extremely large capacitive loads (>400 μ F), the length of the transient due to inrush current may exceed the delay provided by the integrated filter. Since this inrush current exceeds the current-limit delay specification, FLG will be asserted during this time. To prevent the logic controller from responding to FLG being asserted, an external RC filter, as shown in Figure 4, can be used to filter out transient FLG assertion. The value of the RC time constant will be selected to match the length of the transient.

Universal Serial Bus (USB) Power Distribution

The MIC2025/75 is ideally suited for USB (Universal Serial Bus) power distribution applications. The USB specification defines power distribution for USB host systems such as PCs and USB hubs. Hubs can either be self-powered or bus-powered (that is, powered from the bus). Figure 5 below shows a typical USB Host application that may be suited for mobile PC applications employing USB. The requirements for USB host systems is that the port must supply a minimum of 500mA at an output voltage of 5V \pm 5%. In addition, the output power delivered must be limited to below 25VA. Upon an overcurrent condition, the host must also be notified. To support hot-plug events, the hub must have a minimum of 120 μ F of bulk capacitance, preferably low-ESR electrolytic or tantalum. Refer to Application Note 17 for more details on designing compliant USB hub and host systems.

For bus-powered hubs, USB requires that each downstream port be switched on or off under control by the host. Up to four downstream ports each capable of supplying 100mA at 4.4V minimum are allowed. In addition, to reduce voltage droop on the upstream V_{BUS} , soft-start is necessary. Although the hub can consume up to 500mA from the upstream bus the hub must consume only 100mA max at start-up, until it enumerates with the host prior to requesting more power. The same requirements apply for bus-powered peripherals that have no downstream ports. Figure 6 shows a bus-powered hub.

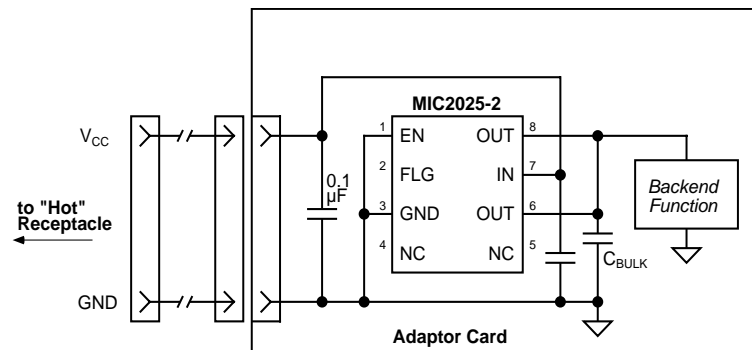

Figure 3. Hot Plug Application

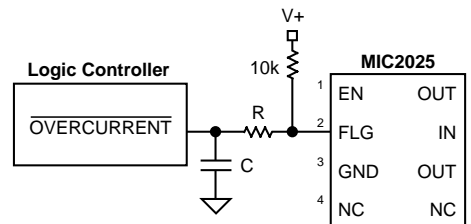

Figure 4. Transient Filter

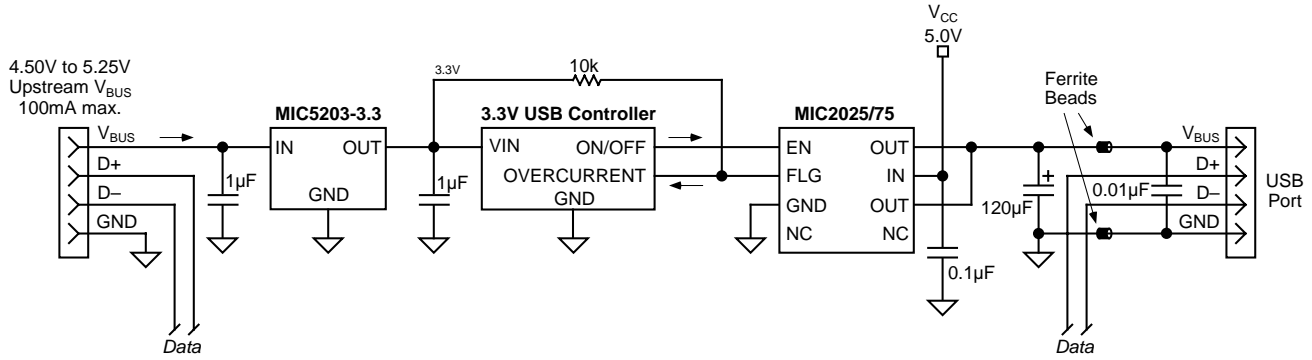

Figure 5 USB Host Application

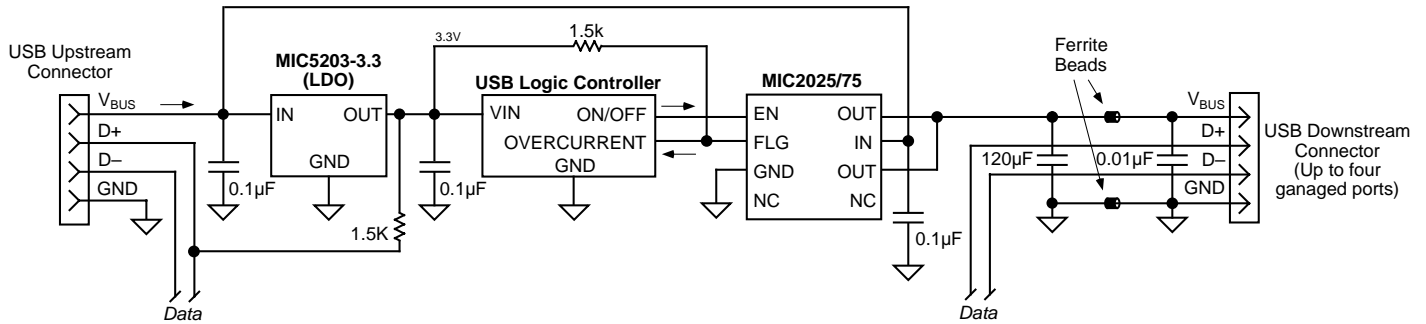
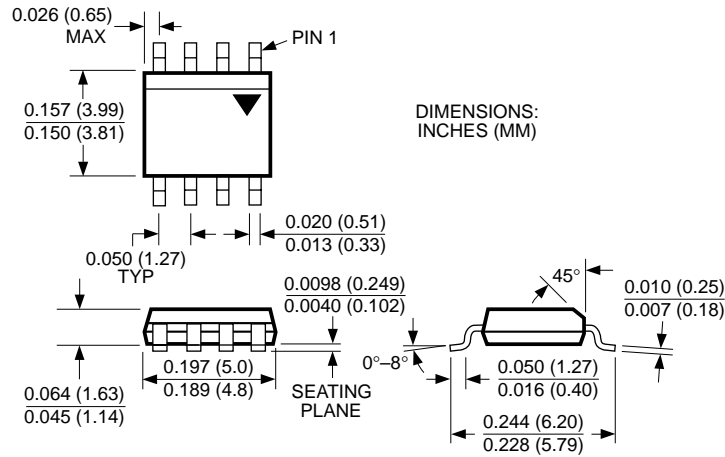
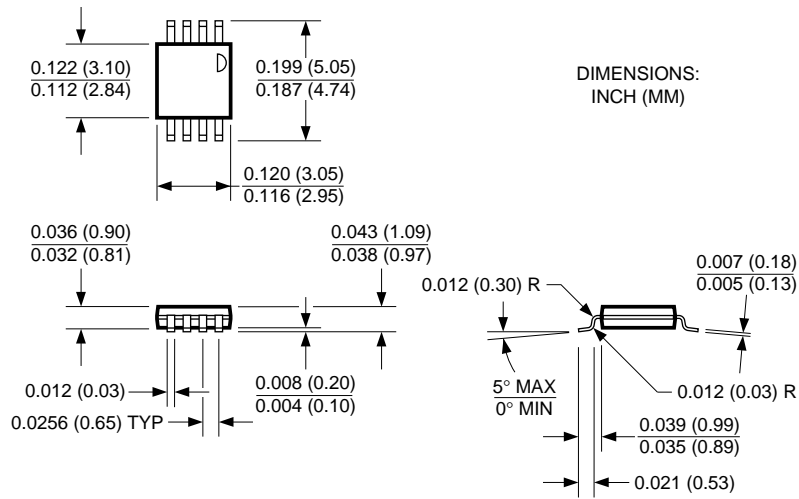

Figure 6. USB Bus-Powered Hub

Package Information



8-Lead SOP (M)



MM8™ 8-Pin MSOP (MM)

MICREL INC. 1849 FORTUNE DRIVE SAN JOSE, CA 95131 USA

TEL + 1 (408) 944-0800 FAX + 1 (408) 944-0970 WEB <http://www.micrel.com>

This information is believed to be accurate and reliable, however no responsibility is assumed by Micrel for its use nor for any infringement of patents or other rights of third parties resulting from its use. No license is granted by implication or otherwise under any patent or patent right of Micrel Inc.

© 2000 Micrel Incorporated