

## Clock Generator for Intel<sup>®</sup> Grantsdale Chipset

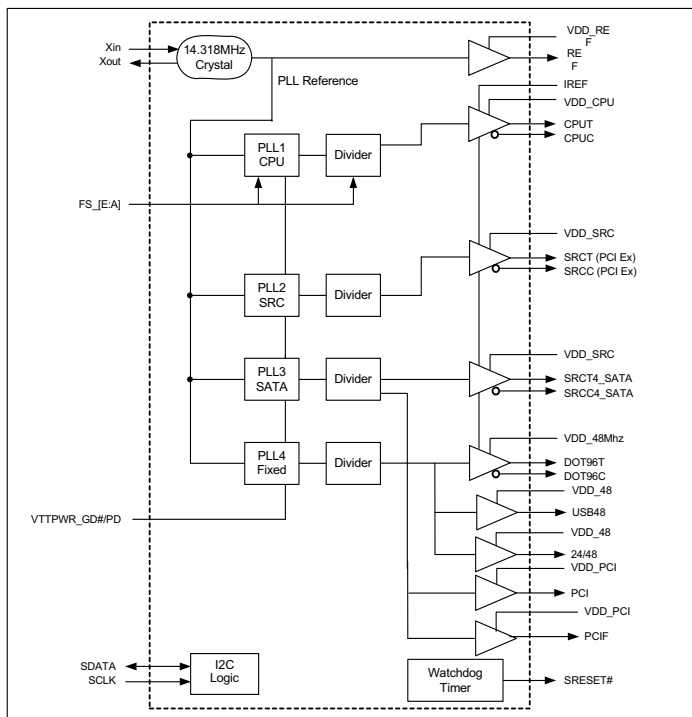
### Features

- Compliant to Intel<sup>®</sup> CK410
- Supports Intel Prescott and Tejas CPU
- Selectable CPU frequencies
- Differential CPU clock pairs
- 100 MHz differential SRC clocks (two selectable between Fixed and Overclocking)
- 96 MHz differential dot clock
- 48 MHz USB clocks
- 33 MHz PCI clock
- Dial-A-Frequency<sup>®</sup>

- Watchdog
- Two independent overclocking PLLs
- Low-voltage frequency select input
- I<sup>2</sup>C support with readback capabilities
- Ideal Lexmark Spread Spectrum profile for maximum electromagnetic interference (EMI) reduction
- 3.3V power supply
- 56-pin SSOP and TSSOP packages

CPU	SRC	PCI	REF	DOT96	USB	24-48M
x 2	x 6	x 9	x 2	x 1	x 1	x 1

### Block Diagram



### Pin Configuration

VSS_PCI	1	VDD_PCI	56
PCI3	2	PCI2	55
*FS_E/PCI4	3	PCI1	54
PCI5	4	PCI0	53
VSS_PCI	5	SRESET#	52
VDD_PCI	6	REF1/FS_D**	51
PCIF0	7	REF0/FS_C**	50
**FS_A/PCIF1	8	VSS_REF	49
*FS_B/PCIF2	9	XIN	48
VDD_48	10	XOUT	47
**SEL24_48#/24_48M	11	VDD_REF	46
USB48	12	SCLK	45
VSS_48	13	SDATA	44
DOT96T	14	CPUT0	43
DOT96C	15	CPUC0	42
VTTTPWRGD#/PD	16	VDD_CPU	41
SRCT0	17	CPUT1	40
SRCCT0	18	CPUC1	39
VDD_SRC	19	VSS_CPU	38
VSS_SRC	20	IREF	37
SRCT1	21	VSSA	36
SRCCT1	22	VDDA	35
SRCT2	23	VDD_SRC	34
SRCCT2	24	SRCT4	33
VSS_SRC	25	SRCCT4	32
SRCT_SATAT	26	SRCT3	31
SRCCT_SATAC	27	SRCCT3	30
VDD_SRC	28	SRCCT4	29

\* Indicates internal pull-up  
 \*\* Indicates internal pull-down

CY28439-2

**Pin Description**

Pin No.	Name	Type	Description
6,56	VDD_PCI	PWR	<b>3.3V power supply for outputs.</b>
1,5	VSS_PCI	GND	<b>Ground for outputs.</b>
3	FS_E/PCI4	I,O, PU,SE	<b>3.3V-tolerant input for CPU frequency selection/33-MHz clock.</b> Refer to DC Electrical Specifications table for $V_{il\_FS}$ and $V_{ih\_FS}$ specifications.
2,4,53,54, 55	PCI	O, SE	<b>33 MHz clocks.</b>
7	PCIF0	O,SE	<b>33 MHz free-running clock</b>
8	FS_A/PCIF1	I/O,PD, SE	<b>3.3V-tolerant input for CPU frequency selection/Free-running 33-MHz clock.</b> Refer to DC Electrical Specifications table for $V_{il\_FS}$ and $V_{ih\_FS}$ specifications.
9	FS_B/PCIF2	I/O,PU, SE	<b>3.3V-tolerant input for CPU frequency selection/Free-running 33-MHz clock.</b> Refer to DC Electrical Specifications table for $V_{il\_FS}$ and $V_{ih\_FS}$ specifications.
16	VTT_PWRGD#/PD	I, PD	<b>3.3V LVTTTL input.</b> This pin is a level sensitive strobe used to latch the FS_A, FS_B, FS_C,FS_D, FS_E, SEL24_48. After VTT_PWRGD# (active LOW) assertion, this pin becomes a real-time input for asserting power-down (active HIGH).
10	VDD_48	PWR	<b>3.3V power supply for outputs.</b>
11	SEL24_48#/24_48 M	I/O, PD, SE	<b>Latched select input for 24-/48-MHz output/ 24-/48-MHz output</b> 0 = 48 MHz, 1 = 24 MHz
12	USB48	I/O,	<b>48 MHz clock output.</b>
13	VSS_48	GND	<b>Ground for outputs.</b>
14,15	DOT96T, DOT96C	O, DIF	<b>Fixed 96 MHz clock output.</b>
17,18,21, 22,23,24, 30,31,32, 33	SRCT/C	O, DIF	<b>Differential serial reference clocks.</b> Outputs have overclocking capability.
19,28,34	VDD_SRC	PWR	<b>3.3V power supply for outputs.</b>
26,27	SRCT/C_SATAT/C	O, DIF	<b>Differential serial reference clock.</b> Recommended output for SATA.
20,25,29	VSS_SRC	GND	<b>Ground for outputs.</b>
35	VDDA	PWR	<b>3.3V power supply for PLL.</b>
36	VSSA	GND	<b>Ground for PLL.</b>
37	IREF	I	<b>A precision resistor is attached to this pin,</b> which is connected to the internal current reference.
41	VDD_CPU	PWR	<b>3.3V power supply for outputs.</b>
39,40,42,43	CPUT/C	O, DIF	<b>Differential CPU clock outputs.</b>
38	VSS_CPU	GND	<b>Ground for outputs.</b>
45	SCLK	I	<b>SMBus-compatible SCLOCK.</b>
44	SDATA	I/O	<b>SMBus-compatible SDATA.</b>
46	VDD_REF	PWR	<b>3.3V power supply for outputs.</b>
47	XOUT	O, SE	<b>14.318 MHz crystal output.</b>
48	XIN	I	<b>14.318 MHz crystal input.</b>
49	VSS_REF	GND	<b>Ground for outputs.</b>
50	REF0/FS_C	I/O, SE, PD	<b>3.3V-tolerant input for CPU frequency selection/Reference clock.</b> Selects test mode if pulled to $V_{IHFS\_C}$ when VTT_PWRGD# is asserted LOW. Refer to DC Electrical Specifications table for $V_{ILFS\_C}$ , $V_{IMFS\_C}$ , $V_{IHFS\_C}$ specifications.
51	REF1/FS_D	O, SE, PD	<b>3.3V-tolerant input for CPU frequency selection/Reference clock.</b> Refer to DC Electrical Specifications table for $V_{il\_FS}$ and $V_{ih\_FS}$ specifications.
52	SRESET#	O, SE	<b>3.3V output for Watchdog reset.</b> This output is open drain type with a high (>100-k $\Omega$ ) internal pull-up resistor.

### Frequency Select Pins (FS\_[A:E])

Host clock frequency selection is achieved by applying the appropriate logic levels to FS\_A, FS\_B, FS\_C, FS\_D, and FS\_E inputs prior to VTT\_PWRGD# assertion (as seen by the clock synthesizer). Upon VTT\_PWRGD# being sampled LOW by the clock chip (indicating processor VTT voltage is stable), the clock chip samples the FS\_A, FS\_B, FS\_C, FS\_D, and FS\_E input values. For all logic levels of FS\_A, FS\_B, FS\_C, FS\_D, and FS\_E, VTT\_PWRGD# employs a one-shot functionality in that once a valid LOW on VTT\_PWRGD# has been sampled, all further VTT\_PWRGD#, FS\_A, FS\_B, FS\_C, FS\_D, and FS\_E transitions will be ignored, except in test mode. FS\_C is a three level input, when sampled at a voltage greater than 2.1V by VTT\_PWRGD#, the device will enter test mode as selected by the voltage level on the FS\_B input.

### Serial Data Interface

To enhance the flexibility and function of the clock synthesizer, a two-signal serial interface is provided. Through the Serial Data Interface, various device functions, such as individual clock output buffers, can be individually enabled or disabled.

The registers associated with the Serial Data Interface initialize to their default setting upon power-up, and therefore use of this interface is optional. Clock device register changes are normally made upon system initialization, if any are required. The interface cannot be used during system operation for power management functions.

### Data Protocol

The clock driver serial protocol accepts byte write, byte read, block write, and block read operations from the controller. For block write/read operation, the bytes must be accessed in sequential order from lowest to highest byte (most significant bit first) with the ability to stop after any complete byte has been transferred. For byte write and byte read operations, the system controller can access individually indexed bytes. The offset of the indexed byte is encoded in the command code, as described in *Table 1*.

The block write and block read protocol is outlined in *Table 2* while *Table 3* outlines the corresponding byte write and byte read protocol. The slave receiver address is 11010010 (D2h).

Input Conditions				Output Frequency									
FS_D	FS_C	FS_B	FS_A	CPU	SRC	CPU PLL Gear Constants	CPU M divider	CPU N DEFAULT	CPU N allowable range for DAF	SRC PLL Gear Constants	SRC M divider (not changeable by user)	SRC N DEFAULT	SRC N allowable range for DAF
FSEL_3	FSEL_2	FSEL_1	FSEL_0	(MHz)	(MHz)	(G)							
0	1	0	1	100	100	30	60	200	200-250	30	60	200	200-266
0	0	0	1	133.3333333	100	40	60	200	200-250	30	60	200	200-266
0	0	1	1	166.6666667	100	60	63	175	175-262	30	60	200	200-266
0	0	1	0	200	100	60	60	200	200-250	30	60	200	200-266
0	0	0	0	266.6666667	100	80	60	200	200-250	30	60	200	200-266
0	1	0	0	333.3333333	100	120	63	175	175-262	30	60	200	200-266
0	1	1	0	400	100	120	60	200	200-250	30	60	200	200-266
1	1	0	1	100.952381	100	30	63	212	212-262	30	60	200	200-266
1	0	0	1	133.968254	100	40	63	211	211-262	30	60	200	200-266
1	0	1	1	167	100	60	60	167	167-250	30	60	200	200-266
1	0	1	0	200.952381	100	60	63	211	211-262	30	60	200	200-266
1	0	0	0	266.6666667	100	80	60	200	200-250	30	60	200	200-266
1	1	0	0	334	100	120	60	167	167-250	30	60	200	200-266
1	1	1	0	400.6451613	100	120	62	207	207-258	30	60	200	167-266

X	HIGH	LOW	X	Tristate	Tristate	Tristate	Tristate	Tristate	Tristate
X	HIGH	HIGH	X	REF/N	REF/N	REF/N	REF/N	REF/N	REF/N

Figure 1. CPU and SRC Frequency Select Tables

**Table 1. Command Code Definition**

Bit	Description
7	0 = Block read or block write operation, 1 = Byte read or byte write operation
(6:0)	Byte offset for byte read or byte write operation. For block read or block write operations, these bits should be '0000000'

**Table 2. Block Read and Block Write Protocol**

Block Write Protocol		Block Read Protocol	
Bit	Description	Bit	Description
1	Start	1	Start
8:2	Slave address – 7 bits	8:2	Slave address – 7 bits
9	Write	9	Write
10	Acknowledge from slave	10	Acknowledge from slave
18:11	Command Code – 8 bits	18:11	Command Code – 8 bits
19	Acknowledge from slave	19	Acknowledge from slave
27:20	Byte Count – 8 bits (Skip this step if I <sup>2</sup> C_EN bit set)	20	Repeat start
28	Acknowledge from slave	27:21	Slave address – 7 bits
36:29	Data byte 1 – 8 bits	28	Read = 1
37	Acknowledge from slave	29	Acknowledge from slave
45:38	Data byte 2 – 8 bits	37:30	Byte Count from slave – 8 bits
46	Acknowledge from slave	38	Acknowledge
....	Data Byte /Slave Acknowledges	46:39	Data byte 1 from slave – 8 bits
....	Data Byte N – 8 bits	47	Acknowledge
....	Acknowledge from slave	55:48	Data byte 2 from slave – 8 bits
....	Stop	56	Acknowledge
		....	Data bytes from slave / Acknowledge
		....	Data Byte N from slave – 8 bits
		....	NOT Acknowledge
		....	Stop

**Table 3. Byte Read and Byte Write Protocol**

Byte Write Protocol		Byte Read Protocol	
Bit	Description	Bit	Description
1	Start	1	Start
8:2	Slave address – 7 bits	8:2	Slave address – 7 bits
9	Write	9	Write
10	Acknowledge from slave	10	Acknowledge from slave
18:11	Command Code – 8 bits	18:11	Command Code – 8 bits
19	Acknowledge from slave	19	Acknowledge from slave
27:20	Data byte – 8 bits	20	Repeated start
28	Acknowledge from slave	27:21	Slave address – 7 bits
29	Stop	28	Read
		29	Acknowledge from slave
		37:30	Data from slave – 8 bits
		38	NOT Acknowledge
		39	Stop

## Control Registers

### Byte 0: Control Register 0

Bit	@Pup	Name	Description
7	1	RESERVED	RESERVED
6	1	SRC[T/C]4	SRC[T/C]4 Output Enable 0 = Disable (Tri-state), 1 = Enable
5	1	SRC[T/C]3	SRC[T/C]3 Output Enable 0 = Disable (Tri-state), 1 = Enable
4	1	SATA[T/C]	SATA[T/C] Output Enable 0 = Disable (Tri-state), 1 = Enable
3	1	SRC[T/C]2	SRC[T/C]2 Output Enable 0 = Disable (Tri-state), 1 = Enable
2	1	SRC[T/C]1	SRC[T/C]1 Output Enable 0 = Disable (Tri-state), 1 = Enable
1	1	RESERVED	RESERVED
0	1	SRC[T/C]0	SRC[T/C]0 Output Enable 0 = Disable (Tri-state), 1 = Enable

### Byte 1: Control Register 1

Bit	@Pup	Name	Description
7	1	PCIF0	PCIF0 Output Enable 0 = Disabled, 1 = Enabled
6	1	DOT_96[T/C]	DOT_96 MHz Output Enable 0 = Disable (Tri-state), 1 = Enabled
5	1	24_48M	24_48 MHz Output Enable 0 = Disabled, 1 = Enabled
4	1	REF0	REF0 Output Enable 0 = Disabled, 1 = Enabled
3	0	RESERVED	RESERVED
2	1	CPU[T/C]1	CPU[T/C]1 Output Enable 0 = Disable (Tri-state), 1 = Enabled
1	1	CPU[T/C]0	CPU[T/C]0 Output Enable 0 = Disable (Tri-state), 1 = Enabled
0	1	CPU	PLL1 (CPU PLL) Spread Spectrum Enable 0 = Spread off, 1 = Spread on

### Byte 2: Control Register 2

Bit	@Pup	Name	Description
7	1	PCI5	PCI5 Output Enable 0 = Disabled, 1 = Enabled
6	1	PCI4	PCI4 Output Enable 0 = Disabled, 1 = Enabled
5	1	PCI3	PCI3 Output Enable 0 = Disabled, 1 = Enabled
4	1	PCI2	PCI2 Output Enable 0 = Disabled, 1 = Enabled
3	1	PCI1	PCI1 Output Enable 0 = Disabled, 1 = Enabled
2	1	PCI0	PCI0 Output Enable 0 = Disabled, 1 = Enabled
1	1	PCIF2	PCIF2 Output Enable 0 = Disabled, 1 = Enabled

**Byte 2: Control Register 2 (continued)**

Bit	@Pup	Name	Description
0	1	PCIF1	PCIF1 Output Enable 0 = Disabled, 1 = Enabled

**Byte 3: Control Register 3**

Bit	@Pup	Name	Description
7	0	RESERVED	RESERVED, Set = 0
6	0	SRC4	Allow control of SRC[T/C]4 with assertion of SW PCI_STP# 0 = Free running, 1 = Stopped with PCI_STP#
5	0	SRC3	Allow control of SRC[T/C]3 with assertion of SW PCI_STP# 0 = Free running, 1 = Stopped with PCI_STP#
4	0	SATA[T/C]	Allow control of SATA[T/C] with assertion of SW PCI_STP# 0 = Free running, 1 = Stopped with PCI_STP#
3	0	SRC2	Allow control of SRC[T/C]2 with assertion of SW PCI_STP# 0 = Free running, 1 = Stopped with PCI_STP#
2	0	SRC1	Allow control of SRC[T/C]1 with assertion of SW PCI_STP# 0 = Free running, 1 = Stopped with PCI_STP#
1	0	RESERVED	RESERVED
0	0	SRC0	Allow control of SRC[T/C]0 with assertion of SW PCI_STP# 0 = Free running, 1 = Stopped with PCI_STP#

**Byte 4: Control Register 4**

Bit	@Pup	Name	Description
7	HW	FS_E	FS_E Reflects the value of the FS_E pin sampled on power-up. 0 = FS_E was low during VTT_PWRGD# assertion.
6	0	DOT96[T/C]	DOT_PWRDWN Drive Mode 0 = Driven in PWRDWN, 1 = Tri-state
5	0	PCIF2	Allow control of SRC[T/C]2 with assertion of SW PCI_STP# 0 = Free running, 1 = Stopped with PCI_STP#
4	0	PCIF1	Allow control of PCIF1 with assertion of SW PCI_STP# 0 = Free running, 1 = Stopped with PCI_STP#
3	0	PCIF0	Allow control of PCIF0 with assertion of SW PCI_STP# 0 = Free running, 1 = Stopped with PCI_STP#
2	1	RESERVED	RESERVED, Set = 1
1	1	RESERVED	RESERVED, Set = 1
0	1	RESERVED	RESERVED, Set = 1

**Byte 5: Control Register 5**

Bit	@Pup	Name	Description
7	0	SRC[T/C]	SRC[T/C] Stop Drive Mode 0 = Driven when PCI_STP# asserted, 1 = Tri-state when PCI_STP# asserted
6	0	RESERVED	RESERVED, Set = 0
5	0	RESERVED	RESERVED, Set = 0
4	0	RESERVED	RESERVED, Set = 0
3	0	SRC[T/C][4:0]	SRC[T/C] PWRDWN Drive Mode 0 = Driven when PD asserted, 1 = Tri-state when PD asserted
2	0	RESERVED	RESERVED, Set = 0
1	0	CPU[T/C]1	CPU[T/C]1 PWRDWN Drive Mode 0 = Driven when PD asserted, 1 = Tri-state when PD asserted
0	0	CPU[T/C]0	CPU[T/C]0 PWRDWN Drive Mode 0 = Driven when PD asserted, 1 = Tri-state when PD asserted

**Byte 6: Control Register 6**

Bit	@Pup	Name	Description
7	0	TEST_SEL	REF/N or Tri-state Select 0 = Tri-state, 1 = REF/N Clock
6	0	TEST_MODE	Test Clock Mode Entry Control 0 = Normal operation, 1 = REF/N or Tri-state mode
5	HW	FS_D	FS_D reflects the value of the FS_D pin sampled on power-up. 0 = FS_D was low during VTT_PWRGD# assertion
4	1	REF	REF Output Drive Strength 0 = High, 1 = Low
3	1	PCI, PCIF and SRC clock outputs except those set to free running	SW PCI_STP# Function 0=SW PCI_STP# assert, 1= SW PCI_STP# deassert When this bit is set to 0, all STOPPABLE PCI, PCIF and SRC outputs will be stopped in a synchronous manner with no short pulses. When this bit is set to 1, all STOPPED PCI, PCIF and SRC outputs will resume in a synchronous manner with no short pulses.
2	HW	FS_C	FS_C Reflects the value of the FS_C pin sampled on power-up 0 = FS_C was low during VTT_PWRGD# assertion
1	HW	FS_B	FS_B Reflects the value of the FS_B pin sampled on power-up 0 = FS_B was low during VTT_PWRGD# assertion
0	HW	FS_A	FS_A Reflects the value of the FS_A pin sampled on power-up 0 = FS_A was low during VTT_PWRGD# assertion

**Byte 7: Vendor ID**

Bit	@Pup	Name	Description
7	0	Revision Code Bit 3	Revision Code Bit 3
6	0	Revision Code Bit 2	Revision Code Bit 2
5	0	Revision Code Bit 1	Revision Code Bit 1
4	0	Revision Code Bit 0	Revision Code Bit 0
3	1	Vendor ID Bit 3	Vendor ID Bit 3
2	0	Vendor ID Bit 2	Vendor ID Bit 2
1	0	Vendor ID Bit 1	Vendor ID Bit 1
0	0	Vendor ID Bit 0	Vendor ID Bit 0

**Byte 8: Control Register 8**

Bit	@Pup	Name	Description
7	0	CPU_SS	Spread Selection for CPU PLL 0: -0.5% (peak to peak) 1: -1.0% (peak to peak)
6	0	CPU_DWN_SS	Spread Selection for CPU PLL 0: Down spread. 1: Center spread
5	0	SRC_SS_OFF	SRC Spread Spectrum Enable 0 = Spread off, 1 = Spread on
4	0	SRC_SS	Spread Selection for SRC PLL 0: -0.5% (peak to peak) 1: -1.0% (peak to peak)
3	0	RESERVED	RESERVED, Set = 0
2	1	USB	USB 48-MHz Output Drive Strength 0 = 2x, 1 = 1x
1	1	PCI	33-MHz Output Drive Strength 0 = 2x, 1 = 1x
0	0	RESERVED	RESERVED

**Byte 9: Control Register 9**

Bit	@Pup	Name	Description
7	0	RESERVED	RESERVED
6	0		
5	0		
4	0		
3	0	FSEL_D	SW Frequency selection bits. See <i>Figure 1</i> .
2	0	FSEL_C	
1	0	FSEL_B	
0	0	FSEL_A	

**Byte 10: Control Register 10**

Bit	@Pup	Name	Description
7	0	Recovery_Frequency	This bit allows selection of the frequency setting that the clock will be restored to once the system is rebooted 0: Use HW settings 1: Recovery N[8:0]
6	0	Timer_SEL	Timer_SEL selects the WD reset function at SRESET pin when WD time out. 0 = Reset and Reload Recovery_Frequency 1 = Only Reset
5	1	Time_Scale	Time_Scale allows selection of WD time scale 0 = 294 ms 1 = 2.34 s
4	0	WD_Alarm	WD_Alarm is set to "1" when the Watchdog times out. It is reset to "0" when the system clears the WD_TIMER time stamp.
3	0	WD_TIMER2	Watchdog timer time stamp selection 000: Reserved (test mode) 001: 1 * Time_Scale 010: 2 * Time_Scale 011: 3 * Time_Scale 100: 4 * Time_Scale 101: 5 * Time_Scale 110: 6 * Time_Scale 111: 7 * Time_Scale
2	0	WD_TIMER1	
1	0	WD_TIMER0	
0	0	WD_EN	

**Byte 11: Control Register 11**

Bit	@Pup	Name	Description
7	0	CPU_DAF_N7	If Prog_CPU_EN is set, the values programmed in CPU_DAF_N[8:0] and CPU_DAF_M[6:0] will be used to determine the CPU output frequency.
6	0	CPU_DAF_N6	
5	0	CPU_DAF_N5	The setting of FS_Override bit determines the frequency ratio for CPU and other output clocks. When it is cleared, the same frequency ratio stated in the Latched FS[E:A] register will be used. When it is set, the frequency ratio stated in the FSEL[3:0] register will be used.
4	0	CPU_DAF_N4	
3	0	CPU_DAF_N3	
2	0	CPU_DAF_N2	
1	0	CPU_DAF_N1	
0	0	CPU_DAF_N0	



**Byte 12: Control Register 12**

Bit	@Pup	Name	Description
7	0	CPU_DAF_N8	If Prog_CPU_EN is set, the values programmed is in CPU_FSEL_N[8:0] and CPU_FSEL_M[6:0] will be used to determine the CPU output frequency. The setting of FS_Override bit determines the frequency ratio for CPU and other output clocks. When it is cleared, the same frequency ratio stated in the Latched FS[E:A] register will be used. When it is set, the frequency ratio stated in the FSEL[3:0] register will be used.
6	0	CPU_DAF_M6	
5	0	CPU_DAF_M5	
4	0	CPU_DAF_M4	
3	0	CPU_DAF_M3	
2	0	CPU_DAF_M2	
1	0	CPU_DAF_M1	
0	0	CPU_DAF_M0	

**Byte 13: Control Register 13**

Bit	@Pup	Name	Description
7	0	SRC_N7	SRC Dial-A-Frequency Bit N7
6	0	SRC_N6	SRC Dial-A-Frequency Bit N6
5	0	SRC_N5	SRC Dial-A-Frequency Bit N5
4	0	SRC_N4	SRC Dial-A-Frequency Bit N4
3	0	SRC_N3	SRC Dial-A-Frequency Bit N3
2	0	SRC_N2	SRC Dial-A-Frequency Bit N2
1	0	SRC_N1	SRC Dial-A-Frequency Bit N1
0	0	SRC_N0	SRC Dial-A-Frequency Bit N0

**Byte 14: Control Register 14**

Bit	@Pup	Name	Description
7	0	SRC_N8	SRC Dial-A-Frequency Bit N8
6	0	SW_RESET	Software Reset. When set the device will assert a reset signal on SRESET# upon completion of the block/word/byte write that set it. After asserting and deasserting the SRESET# this bit will self clear (set to 0). The SRESET# pin must be enabled by latching SRESET#_EN on VTT_PRWGD# to utilize this feature.
5	0	FS_[E:A]	FS_Override 0 = Select operating frequency by FS(E:A) input pins 1 = Select operating frequency by FSEL_(4:0) settings
4	0	SMSW_SEL	Smooth switch select 0: Select CPU_PLL 1: Select SRC_PLL.
3	0	RESERVED	RESERVED, Set = 0
2	0	RESERVED	RESERVED, Set = 0
1	1	PCIF	Free running 33-MHz Output Drive Strength 0 = 2x, 1 = 1x
0	0	Recovery_N8	Watchdog Recovery Bit

**Byte 15: Control Register 15**

Bit	@Pup	Name	Description
7	0	Recovery N7	Watchdog Recovery Bit
6	0	Recovery N6	Watchdog Recovery Bit
5	0	Recovery N5	Watchdog Recovery Bit
4	0	Recovery N4	Watchdog Recovery Bit
3	0	Recovery N3	Watchdog Recovery Bit

**Byte 15: Control Register 15 (continued)**

Bit	@Pup	Name	Description
2	0	Recovery N2	Watchdog Recovery Bit
1	0	Recovery N1	Watchdog Recovery Bit
0	0	Recovery N0	Watchdog Recovery Bit

**Byte 16: Control Register 16**

Bit	@Pup	Name	Description
7	1	REF1	REF1 Output Enable 0 = Disable, 1 = Enable
6	1	USB48	USB48 Output Enable 0 = Disable, 1 = Enable
5	0	SRC_FREQ_SEL	SRC Frequency selection 0: SRC frequency is selected via the FS_E pin 1: SRC frequency is initially set to 167 MHz.
4	0	RESERVED	RESERVED
3	0	SRC_SATA	SATA PLL Spread Spectrum Enable 0 = Spread off, 1 = Spread on
2	0	Prog_SRC_EN	Programmable SRC frequency enable 0 = disabled, 1 = enabled.
1	0	Prog_CPU_EN	Programmable CPU frequency enable 0 = disabled, 1 = enabled.
0	0	Watchdog Autorecovery	Watchdog Autorecovery Mode 0 = Disable (Manual), 1 = Enable (Auto)

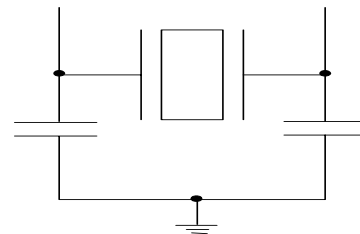
The CY28439-2 requires a Parallel Resonance Crystal. Substituting a series resonance crystal will cause the CY28439-2 to operate at the wrong frequency and violate the ppm specification. For most applications there is a 300-ppm frequency shift between series and parallel crystals due to incorrect loading.

**Crystal Loading**

Crystal loading plays a critical role in achieving low ppm performance. To realize low ppm performance, the total capacitance the crystal will see must be considered to calculate the appropriate capacitive loading (CL).

Figure 2 shows a typical crystal configuration using the two trim capacitors. An important clarification for the following discussion is that the trim capacitors are in series with the

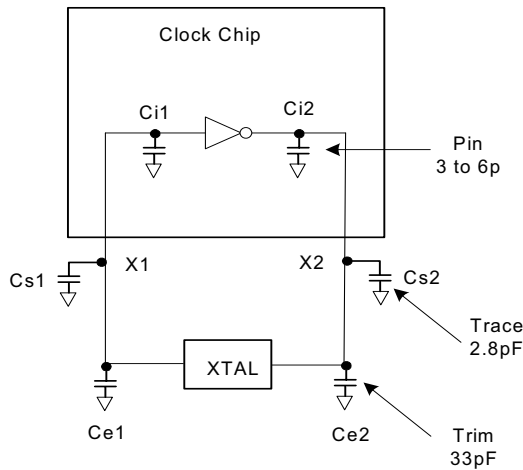
crystal not parallel. It's a common misconception that load capacitors are in parallel with the crystal and should be approximately equal to the load capacitance of the crystal. This is not true.


**Figure 2. Crystal Capacitive Clarification**
**Table 4. Crystal Recommendations**

Frequency (Fund)	Cut	Loading	Load Cap	Drive (max.)	Shunt Cap (max.)	Motional (max.)	Tolerance (max.)	Stability (max.)	Aging (max.)
14.31818 MHz	AT	Parallel	20 pF	0.1 mW	5 pF	0.016 pF	35 ppm	30 ppm	5 ppm

## Calculating Load Capacitors

In addition to the standard external trim capacitors, trace capacitance and pin capacitance must also be considered to correctly calculate crystal loading. As mentioned previously, the capacitance on each side of the crystal is in series with the crystal. This means the total capacitance on each side of the crystal must be twice the specified crystal load capacitance (CL). While the capacitance on each side of the crystal is in series with the crystal, trim capacitors (Ce1,Ce2) should be calculated to provide equal capacitive loading on both sides.



**Figure 3. Crystal Loading Example**

Use the following formulas to calculate the trim capacitor values for Ce1 and Ce2.

### Load Capacitance (each side)

$$C_e = 2 * CL - (C_s + C_i)$$

### Total Capacitance (as seen by the crystal)

$$CL_e = \frac{1}{\left( \frac{1}{C_{e1} + C_{s1} + C_{i1}} + \frac{1}{C_{e2} + C_{s2} + C_{i2}} \right)}$$

CL .....	Crystal load capacitance
CL <sub>e</sub> .....	Actual loading seen by crystal using standard value trim capacitors
C <sub>e</sub> .....	External trim capacitors
C <sub>s</sub> .....	Stray capacitance (terraced)
C <sub>i</sub> .....	Internal capacitance (lead frame, bond wires etc.)
CL .....	Crystal load capacitance
CL <sub>e</sub> .....	Actual loading seen by crystal using standard value trim capacitors
C <sub>e</sub> .....	External trim capacitors
C <sub>s</sub> .....	Stray capacitance (terraced)
C <sub>i</sub> .....	Internal capacitance (lead frame, bond wires etc.)

## Dial-A-Frequency (CPU and SRC)

This feature allows the user to overclock their system by slowly stepping up the CPU or SRC frequency. When the programmable output frequency feature is enabled, the CPU and SRC frequencies are determined by the following equation

$$F_{cpu} = G * N/M \text{ or } F_{cpu} = G^2 * N, \text{ where } G^2 = G / M$$

“N” and “M” are the values programmed in Programmable Frequency Select N-Value Register and M-Value Register, respectively. “G” stands for the PLL Gear Constant, which is determined by the programmed value of FS[E:A]. See *Figure 1* for the Gear Constant for each Frequency selection. The PCI Express only allows user control of the N register, the M value is fixed and documented in *Figure 1*.

In this mode, the user writes the desired N and M value into the DAF I2C registers. The user cannot change only the M value and must change both the M and the N values at the same time, if they require a change to the M value. The user may change only the N value if required.

### Associated Register Bits

**CPU\_DAF Enable**—This bit enables CPU DAF mode. By default, it is not set. When set, the operating frequency is determined by the values entered into the CPU\_DAF\_N register. **Note:** the CPU\_DAF\_N and M register must contain valid values before CPU\_DAF is set. Default = 0, (No DAF).

**CPU\_DAF\_N**—There will be nine bits (for 512 values) to linearly change the CPU frequency (limited by VCO range). Default = 0, (0000) The allowable values for N are detailed in the frequency select table in *Figure 1*.

**CPU DAF M**—There will be 7 bits (for 128 values) to linearly change the CPU frequency (limited by VCO range). Default = 0, the allowable values for M are detailed in the frequency select table in *Figure 1*.

**SRC\_DAF Enable**—This bit enables SRC DAF mode. By default, it is not set. When set, the operating frequency is determined by the values entered into the SRC\_DAF\_N register. **Note:** the SRC\_DAF\_N register must contain valid values before SRC\_DAF is set. Default = 0, (No DAF).

**SRC\_DAF\_N**—There are nine bits (for 512 values) to linearly change the CPU frequency (limited by VCO range). Default = 0, (0000) The allowable values for N are detailed in the frequency select table in *Figure 1*.

**Recovery**—The recovery mechanism during CPU DAF when the system locks up and the Watchdog timer is enabled is determined by the “Watchdog Recovery Mode” and “Watchdog Autorecovery Enable” bits. The possible recovery methods are: (A) Auto, (B) Manual (by Recovery N), (C) HW, and (D) No recovery, just send reset signal.

There is no recovery mode for SRC Dial-a-Frequency.

### Software Frequency Select

This mode allows the user to select the CPU output frequencies using the Software Frequency select bits in the SMBUS register.

**FSEL**—There will be four bits (for 16 combinations) to select predetermined CPU frequencies from a table. The table selections are detailed in section *Figure 1*.

**FS\_Override**—This bit allows the CPU frequency to be selected from HW or FSEL settings. By default, this bit is not set and the CPU frequency is selected by HW. When this bit is set, the CPU frequency is selected by the FSEL bits. Default = 0.

**Recovery**—The recovery mechanism during FSEL when the system locks up is determined by the “Watchdog Recovery Mode” and “Watchdog Autorecovery Enable” bits. The only possible recovery method is to (?) Hardware Settings. Auto recovery or manual recovery can cause a wrong output frequency because the output divider may have changed with the selected CPU frequency and these recovery methods will not recover the original output divider setting.

## Smooth Switching

The device contains one smooth switch circuit which is shared by the CPU PLL and SRC PLL. The smooth switch circuit ensures that when the output frequency changes by overclocking, the transition from the old frequency to the new frequency is a slow, smooth transition containing no glitches. The rate of change of output frequency when using the smooth switch circuit is less than 1 MHz/0.667  $\mu$ s. The frequency overshoot and undershoot will be less than 2%.

The Smooth Switch circuit can be assigned to either PLL via register byte 14 bit 4. By default the smooth switch circuit is assigned to the CPU PLL. Either PLL can still be overclocked when it does not have control of the smooth switch circuit but it is not guaranteed to transition to the new frequency without large frequency glitches.

It is not recommended to enable overclocking and change the N values of both PLLs in the same SMBUS block write.

## Watchdog Timer

The Watchdog timer is used in the system in conjunction with overclocking. It is used to provide a reset to a system that has hung up due to overclocking the CPU and the Front side bus. The Watchdog is enabled by the user and if the system completes its checkpoints, the system will clear the timer. However, when the timer runs out, there will be a reset pulse generated on the SRESET# pin for 20 ms that is used to reset the system.

When the Watchdog is enabled (WD\_EN = 1) the Watchdog timer will start counting down from a value of Watchdog\_timer \* time scale. If the Watchdog timer reaches 0 before the WD\_EN bit is cleared then it will assert the SRESET# signal and set the Watchdog Alarm bit to 1.

To use the Watchdog the SRESET# pin must be enabled by SRESET\_EN pin being sampled low by VTPWRGD# assertion during system boot-up.

At any point if during the Watchdog timer countdown, if the time stamp or Watchdog timer bits are changed the timer will reset and start counting down from the new value.

After the Reset pulse, the Watchdog will stay inactive until either:

1. A new time stamp or Watchdog timer value is loaded.
2. The WD\_EN bit is cleared and then set again.

## Watchdog Register Bits

The following register bits are associated with the Watchdog timer:

**Watchdog Enable**—This bit (by default) is not set, which disables the Watchdog. When set, the Watchdog is enabled. Also, when there is a transition from LOW to HIGH, the timer reloads. Default = 0, disable

**Watchdog Timer**—There will be three bits (for seven combinations) to select the timer value. Default = 000—the Value '000' is a reserved test mode.

**Watchdog Alarm**—This bit is a flag and when it is set, it indicates that the timer has expired. This bit is not set by default. When the bit is set, the user is allowed to clear. Default = 0.

**Watchdog Time Scale**—This bit selects the multiplier. When this bit is not set, the multiplier will be 250 ms. When set (by default), the multiplier will be 3s. Default = 1.

**Watchdog Reset Mode**—This selects the Watchdog reset mode. When this bit is not set (by default), the Watchdog will send a reset pulse and reload the recovery frequency, which depends on Watchdog Recovery Mode setting. When set, it just sends a reset pulse. Default = 0, Reset & Recover Frequency.

**Watchdog Recovery Mode**—This bit selects the location to recover from. One option is to recover from the HW settings (already stored in SMBUS registers for readback capability) and the second is to recover from a register called “Recovery N”. Default = 0 (Recover from the HW setting).

**Watchdog Autorecovery Enable**—This bit by default is set and the recovered values are automatically written into the “Watchdog Recovery Register” and reloaded by the Watchdog function. When this bit is not set, the user is allowed to write to the “Watchdog Recovery Register”. The value stored in the “Watchdog Recovery Register” will be used for recovery. Default = 1, Autorecovery.

**Watchdog Recovery Register**—This is a nine-bit register to store the Watchdog N recovery value. This value can be written by the Autorecovery or User depending on the state of the “Watchdog Autorecovery Enable bit”.

## Watchdog Recovery Modes

There are two operating modes that requires Watchdog recovery. The modes are Dial-A-Frequency (DAF) or Frequency Select. There are four different recovery modes: The following diagram lists the operating mode and the recovery mode associated with it.

### Recover to Hardware M, N, O

When this recovery mode is selected, in the event of a Watchdog timeout, the original M, N, and O values that were latched by the HW FSEL pins at Chip boot-up should be reloaded.

### Autorecovery

When this recovery mode is selected, in the event of a Watchdog timeout, the M and N values stored in the Recovery M and N registers should be reloaded. The current values of M and N will be latched into the internal recovery M and N registers by the WD\_EN bit being set.

### Manual Recovery

When this recovery mode is selected, in the event of a Watchdog timeout, the N value as programmed by the user in the N recovery register, and the M value that is stored in the Recovery M register (not accessible by the user) should be restored. The current M value should be latched into the M recovery register by the WD\_EN bit being set.

### No Recovery

If no recovery mode is selected, in the event of a Watchdog time out, the device should just assert the SRESET# and keep the current values of M and N.

### Software Reset

Software reset is a reset function which is used to send out a pulse from SRESET# pin. It is controlled by the SW\_RESET enable register bit. Upon completion of the byte/word/block write in which the SW\_RESET bit was set, the device will send a RESET pulse on the SRESET# pin. The duration of the SRESET# pulse should be the same as the duration of the SRESET# pulse after a Watchdog timer time out.

After the SRESET# pulse is asserted the SW\_RESET bit should be automatically cleared by the device.

### PD (Power-down) Clarification

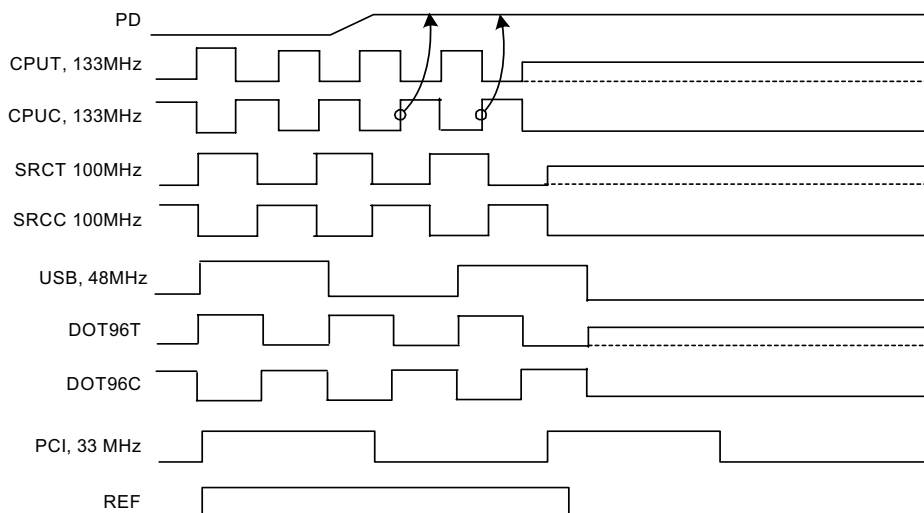
The VTT\_PWRGD# /PD pin is a dual-function pin. During initial power-up, the pin functions as VTT\_PWRGD#. Once VTT\_PWRGD# has been sampled LOW by the clock chip, the pin assumes PD functionality. The PD pin is an asynchronous active HIGH input used to shut off all clocks cleanly prior to shutting off power to the device. This signal is synchronized internal to the device prior to powering down the clock synthesizer. PD is also an asynchronous input for powering up the system. When PD is asserted HIGH, all clocks need to be driven to a LOW value and held prior to turning off the VCOs and the crystal oscillator.

### PD (Power-down)—Assertion

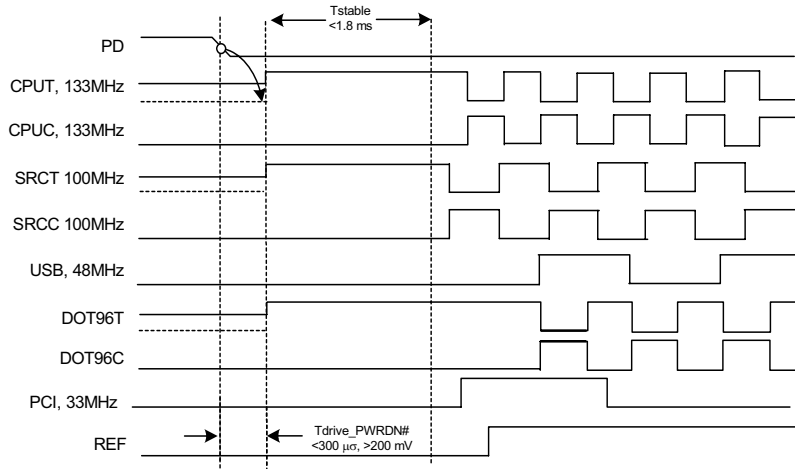
When PD is sampled HIGH by two consecutive rising edges of CPUC, all single-ended outputs will be held LOW on their next HIGH-to-LOW transition and differential clocks must held high or tri-stated (depending on the state of the control register drive mode bit) on the next diff clock# HIGH-to-LOW transition within 4 clock periods. When the SMBus PD drive mode bit corresponding to the differential (CPU, SRC, and DOT) clock output of interest is programmed to '0', the clock output is held with "Diff clock" pin driven HIGH at  $2 \times I_{ref}$ , and "Diff clock#" tri-state. If the control register PD drive mode bit corresponding to the output of interest is programmed to "1", then both the "Diff clock" and the "Diff clock#" are tri-state. Note the example below shows CPU<sub>T</sub> = 133 MHz and PD drive mode = '1' for all differential outputs. This diagram and description is applicable to valid CPU frequencies 100, 133, 166, 200, 266, 333, and 400 MHz. In the event that PD mode is desired as the initial power-on state, PD must be asserted HIGH in less than 10  $\mu$ s after asserting Vtt\_PwrGd#.

### PD Deassertion

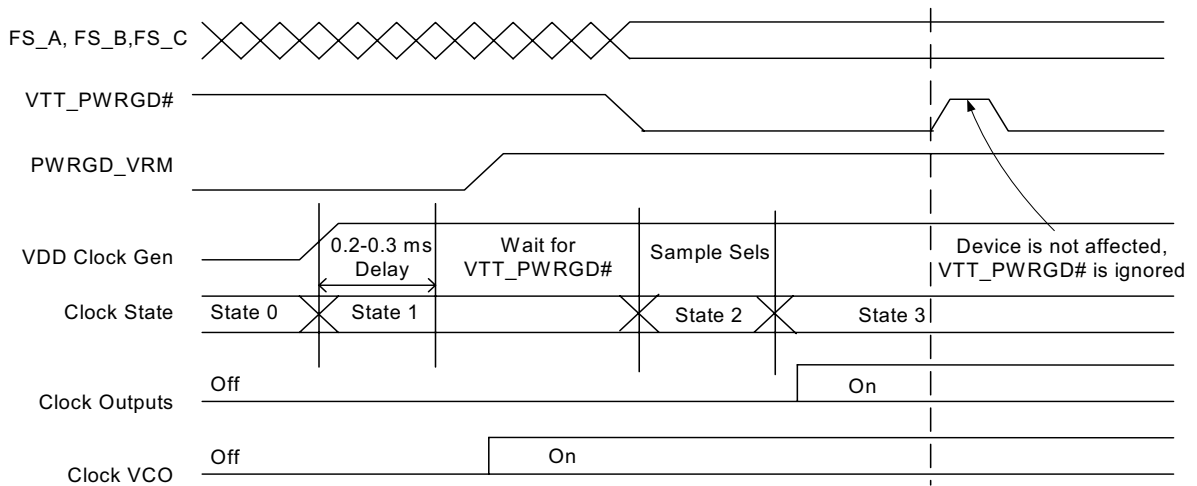
The power-up latency is less than 1.8 ms. This is the time from the deassertion of the PD pin or the ramping of the power supply until the time that stable clocks are output from the clock chip. All differential outputs stopped in a three-state condition resulting from power down will be driven high in less than 300  $\mu$ s of PD deassertion to a voltage greater than 200 mV. After the clock chip's internal PLL is powered up and locked, all outputs will be enabled within a few clock cycles of each other. *Figure 5* is an example showing the relationship of clocks coming up.



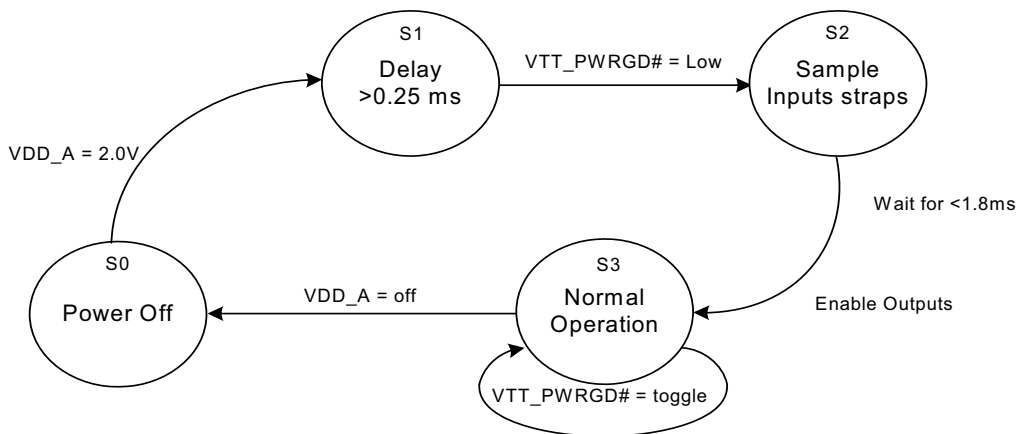
**Figure 4. Power-down Assertion Timing Waveform**



**Figure 5. Power-down Deassertion Timing Waveform**



**Figure 6. VTT\_PWRGD# Timing Diagram**



**Figure 7. Clock Generator Power-up/Run State Diagram**

### Absolute Maximum Conditions

Parameter	Description	Condition	Min.	Max.	Unit
V <sub>DD</sub>	Core Supply Voltage		-0.5	4.6	V
V <sub>DD_A</sub>	Analog Supply Voltage		-0.5	4.6	V
V <sub>IN</sub>	Input Voltage	Relative to V <sub>SS</sub>	-0.5	V <sub>DD</sub> + 0.5	VDC
T <sub>S</sub>	Temperature, Storage	Non-functional	-65	150	°C
T <sub>A</sub>	Temperature, Operating Ambient	Functional	0	70	°C
T <sub>J</sub>	Temperature, Junction	Functional	-	150	°C
∅ <sub>JC</sub>	Dissipation, Junction to Case	Mil-STD-883E Method 1012.1	-	20	°C/W
∅ <sub>JA</sub>	Dissipation, Junction to Ambient	JEDEC (JESD 51)	-	60	°C/W
ESD <sub>HBM</sub>	ESD Protection (Human Body Model)	MIL-STD-883, Method 3015	2000	-	V
UL-94	Flammability Rating	At 1/8 in.	V-0		
MSL	Moisture Sensitivity Level		1		

**Multiple Supplies:** The voltage on any input or I/O pin cannot exceed the power pin during power-up. Power supply sequencing is NOT required.

### DC Electrical Specifications

Parameter	Description	Condition	Min.	Max.	Unit
All V <sub>DDs</sub>	3.3V Operating Voltage	3.3 ± 5%	3.135	3.465	V
V <sub>IL12C</sub>	Input Low Voltage	SDATA, SCLK	-	1.0	V
V <sub>IH12C</sub>	Input High Voltage	SDATA, SCLK	2.2	-	V
V <sub>IL_FS</sub>	FS_[A:B,D:E] Input Low Voltage		V <sub>SS</sub> - 0.3	0.35	V
V <sub>IH_FS</sub>	FS_[A:B,D:E] Input High Voltage		0.7	V <sub>DD</sub> + 0.5	V
V <sub>ILFS_C</sub>	FS_C Low Range		0	0.35	V
V <sub>IMFS_C</sub>	FS_C Mid Range		0.7	1.7	V
V <sub>IH_FS_C</sub>	FS_C High Range		2.1	V <sub>DD</sub>	V
V <sub>IL</sub>	3.3V Input Low Voltage		V <sub>SS</sub> - 0.3	0.8	V
V <sub>IH</sub>	3.3V Input High Voltage		2.0	V <sub>DD</sub> + 0.3	V
I <sub>IL</sub>	Input Low Leakage Current	Except internal pull-up resistors, 0 < V <sub>IN</sub> < V <sub>DD</sub>	-5	-	μA
I <sub>IH</sub>	Input High Leakage Current	Except internal pull-down resistors, 0 < V <sub>IN</sub> < V <sub>DD</sub>	-	5	μA
V <sub>OL</sub>	3.3V Output Low Voltage	I <sub>OL</sub> = 1 mA	-	0.4	V
V <sub>OH</sub>	3.3V Output High Voltage	I <sub>OH</sub> = -1 mA	2.4	-	V
I <sub>OZ</sub>	High-impedance Output Current		-10	10	μA
C <sub>IN</sub>	Input Pin Capacitance		3	5	pF
C <sub>OUT</sub>	Output Pin Capacitance		3	5	pF
L <sub>IN</sub>	Pin Inductance		-	7	nH
V <sub>XIH</sub>	Xin High Voltage		0.7V <sub>DD</sub>	V <sub>DD</sub>	V
V <sub>XIL</sub>	Xin Low Voltage		0	0.3V <sub>DD</sub>	V
I <sub>DD3.3V</sub>	Dynamic Supply Current	At max. load and freq. per <i>Figure 10</i>	-	500	mA
I <sub>PD3.3V</sub>	Power-down Supply Current	PD asserted, Outputs Driven	-	70	mA
I <sub>PT3.3V</sub>	Power-down Supply Current	PD asserted, Outputs Tri-state	-	2	mA

**AC Electrical Specifications**

Parameter	Description	Condition	Min.	Max.	Unit
<b>Crystal</b>					
T <sub>DC</sub>	XIN Duty Cycle	The device will operate reliably with input duty cycles up to 30/70 but the REF clock duty cycle will not be within specification	47.5	52.5	%
T <sub>PERIOD</sub>	XIN Period	When XIN is driven from an external clock source	69.841	71.0	ns
T <sub>R</sub> / T <sub>F</sub>	XIN Rise and Fall Times	Measured between 0.3V <sub>DD</sub> and 0.7V <sub>DD</sub>	–	10.0	ns
T <sub>CCJ</sub>	XIN Cycle to Cycle Jitter	As an average over 1- $\mu$ s duration	–	500	ps
L <sub>ACC</sub>	Long-term Accuracy	Over 150 ms	–	300	ppm
<b>CPU at 0.7V (SSC refers to –0.5% spread spectrum)</b>					
T <sub>DC</sub>	CPUT and CPUC Duty Cycle	Measured at crossing point V <sub>OX</sub>	45	55	%
T <sub>PERIOD</sub>	100-MHz CPUT and CPUC Period	Measured at crossing point V <sub>OX</sub>	9.997001	10.00300	ns
T <sub>PERIOD</sub>	133-MHz CPUT and CPUC Period	Measured at crossing point V <sub>OX</sub>	7.497751	7.502251	ns
T <sub>PERIOD</sub>	166-MHz CPUT and CPUC Period	Measured at crossing point V <sub>OX</sub>	5.998201	6.001801	ns
T <sub>PERIOD</sub>	200-MHz CPUT and CPUC Period	Measured at crossing point V <sub>OX</sub>	4.998500	5.001500	ns
T <sub>PERIOD</sub>	266-MHz CPUT and CPUC Period	Measured at crossing point V <sub>OX</sub>	3.748875	3.751125	ns
T <sub>PERIOD</sub>	333-MHz CPUT and CPUC Period	Measured at crossing point V <sub>OX</sub>	2.999100	3.000900	ns
T <sub>PERIOD</sub>	400-MHz CPUT and CPUC Period	Measured at crossing point V <sub>OX</sub>	2.499250	2.500750	ns
T <sub>PERIODSS</sub>	100-MHz CPUT and CPUC Period, SSC	Measured at crossing point V <sub>OX</sub>	9.997001	10.05327	ns
T <sub>PERIODSS</sub>	133-MHz CPUT and CPUC Period, SSC	Measured at crossing point V <sub>OX</sub>	7.497751	7.539950	ns
T <sub>PERIODSS</sub>	166-MHz CPUT and CPUC Period, SSC	Measured at crossing point V <sub>OX</sub>	5.998201	6.031960	ns
T <sub>PERIODSS</sub>	200-MHz CPUT and CPUC Period, SSC	Measured at crossing point V <sub>OX</sub>	4.998500	5.026634	ns
T <sub>PERIODSS</sub>	266-MHz CPUT and CPUC Period, SSC	Measured at crossing point V <sub>OX</sub>	3.748875	3.769975	ns
T <sub>PERIODSS</sub>	333-MHz CPUT and CPUC Period, SSC	Measured at crossing point V <sub>OX</sub>	2.999100	3.015980	ns
T <sub>PERIODSS</sub>	400-MHz CPUT and CPUC Period, SSC	Measured at crossing point V <sub>OX</sub>	2.499250	2.513317	ns
T <sub>PERIODAbs</sub>	100-MHz CPUT and CPUC Absolute period	Measured at crossing point V <sub>OX</sub>	9.912001	10.08800	ns
T <sub>PERIODAbs</sub>	133-MHz CPUT and CPUC Absolute period	Measured at crossing point V <sub>OX</sub>	7.412751	7.587251	ns
T <sub>PERIODAbs</sub>	166-MHz CPUT and CPUC Absolute period	Measured at crossing point V <sub>OX</sub>	5.913201	6.086801	ns
T <sub>PERIODAbs</sub>	200-MHz CPUT and CPUC Absolute period	Measured at crossing point V <sub>OX</sub>	4.913500	5.086500	ns
T <sub>PERIODAbs</sub>	266-MHz CPUT and CPUC Absolute period	Measured at crossing point V <sub>OX</sub>	3.663875	3.836125	ns
T <sub>PERIODAbs</sub>	333-MHz CPUT and CPUC Absolute period	Measured at crossing point V <sub>OX</sub>	2.914100	3.085900	ns
T <sub>PERIODAbs</sub>	400-MHz CPUT and CPUC Absolute period	Measured at crossing point V <sub>OX</sub>	2.414250	2.585750	ns
T <sub>PERIODSSAbs</sub>	100-MHz CPUT and CPUC Absolute period, SSC	Measured at crossing point V <sub>OX</sub>	9.912001	10.13827	ns
T <sub>PERIODSSAbs</sub>	133-MHz CPUT and CPUC Absolute period, SSC	Measured at crossing point V <sub>OX</sub>	7.412751	7.624950	ns
T <sub>PERIODSSAbs</sub>	166-MHz CPUT and CPUC Absolute period, SSC	Measured at crossing point V <sub>OX</sub>	5.913201	6.116960	ns
T <sub>PERIODSSAbs</sub>	200-MHz CPUT and CPUC Absolute period, SSC	Measured at crossing point V <sub>OX</sub>	4.913500	5.111634	ns
T <sub>PERIODSSAbs</sub>	266-MHz CPUT and CPU C Absolute period, SSC	Measured at crossing point V <sub>OX</sub>	3.663875	3.854975	ns
T <sub>PERIODSSAbs</sub>	333-MHz CPUT and CPUC Absolute period, SSC	Measured at crossing point V <sub>OX</sub>	2.914100	3.100980	ns
T <sub>PERIODSSAbs</sub>	400-MHz CPUT and CPUC Absolute period, SSC	Measured at crossing point V <sub>OX</sub>	2.414250	2.598317	ns
T <sub>SKEW</sub>	CPU0 to CPU1	Measured at crossing point V <sub>OX</sub>	–	100	ps



**AC Electrical Specifications** (continued)

Parameter	Description	Condition	Min.	Max.	Unit
T <sub>CCJ</sub>	CPUT/C Cycle to Cycle Jitter	Measured at crossing point V <sub>OX</sub>	–	80	ps
L <sub>ACC</sub>	Long Term accuracy	Measured using frequency counter over 0.15 seconds.	–	300	ppm
T <sub>R</sub> / T <sub>F</sub>	CPUT and CPUC Rise and Fall Times	Measured from V <sub>OL</sub> = 0.175 to V <sub>OH</sub> = 0.525V	130	700	ps
T <sub>RFM</sub>	Rise/Fall Matching	Determined as a fraction of 2*(T <sub>R</sub> – T <sub>F</sub> )/(T <sub>R</sub> + T <sub>F</sub> )	–	20	%
ΔT <sub>R</sub>	Rise Time Variation		–	125	ps
ΔT <sub>F</sub>	Fall Time Variation		–	125	ps
V <sub>HIGH</sub>	Voltage High	Math averages <i>Figure 10</i>	660	850	mV
V <sub>LOW</sub>	Voltage Low	Math averages <i>Figure 10</i>	–150	–	mV
V <sub>OX</sub>	Crossing Point Voltage at 0.7V Swing		250	550	mV
V <sub>OVS</sub>	Maximum Overshoot Voltage		–	V <sub>HIGH</sub> + 0.3	V
V <sub>UDS</sub>	Minimum Undershoot Voltage		–0.3	–	V
V <sub>RB</sub>	Ring Back Voltage	See <i>Figure 10</i> . Measure SE	–	0.2	V
<b>SRC</b>					
T <sub>DC</sub>	SRCT and SRCC Duty Cycle	Measured at crossing point V <sub>OX</sub>	45	55	%
T <sub>PERIOD</sub>	100-MHz SRCT and SRCC Period	Measured at crossing point V <sub>OX</sub>	9.997001	10.00300	ns
T <sub>PERIODSS</sub>	100-MHz SRCT and SRCC Period, SSC	Measured at crossing point V <sub>OX</sub>	9.997001	10.05327	ns
T <sub>PERIODAbs</sub>	100-MHz SRCT and SRCC Absolute Period	Measured at crossing point V <sub>OX</sub>	9.872001	10.12800	ns
T <sub>PERIODSSAbs</sub>	100-MHz SRCT and SRCC Absolute Period, SSC	Measured at crossing point V <sub>OX</sub>	9.872001	10.17827	ns
T <sub>SKEW</sub>	Any SRCT/C to SRCT/C Clock Skew	Measured at crossing point V <sub>OX</sub>	–	250	ps
T <sub>CCJ</sub>	SRCT/C Cycle to Cycle Jitter	Measured at crossing point V <sub>OX</sub>	–	65	ps
L <sub>ACC</sub>	SRCT/C Long Term Accuracy	Measured at crossing point V <sub>OX</sub>	–	300	ppm
T <sub>R</sub> / T <sub>F</sub>	SRCT and SRCC Rise and Fall Times	Measured from V <sub>OL</sub> = 0.175 to V <sub>OH</sub> = 0.525V	130	700	ps
T <sub>RFM</sub>	Rise/Fall Matching	Determined as a fraction of 2*(T <sub>R</sub> – T <sub>F</sub> )/(T <sub>R</sub> + T <sub>F</sub> )	–	20	%
ΔT <sub>R</sub>	Rise Time Variation		–	125	ps
ΔT <sub>F</sub>	Fall Time Variation		–	125	ps
V <sub>HIGH</sub>	Voltage High	Math averages <i>Figure 10</i>	660	850	mV
V <sub>LOW</sub>	Voltage Low	Math averages <i>Figure 10</i>	–150	–	mV
V <sub>OX</sub>	Crossing Point Voltage at 0.7V Swing		250	550	mV
V <sub>OVS</sub>	Maximum Overshoot Voltage		–	V <sub>HIGH</sub> + 0.3	V
V <sub>UDS</sub>	Minimum Undershoot Voltage		–0.3	–	V
V <sub>RB</sub>	Ring Back Voltage	See <i>Figure 10</i> . Measure SE	–	0.2	V
<b>PCI/PCIF</b>					
T <sub>DC</sub>	PCI Duty Cycle	Measurement at 1.5V	45	55	%
T <sub>PERIOD</sub>	Spread Disabled PCIF/PCI Period	Measurement at 1.5V	29.99100	30.00900	ns
T <sub>PERIODSS</sub>	Spread Enabled PCIF/PCI Period, SSC	Measurement at 1.5V	29.9910	30.15980	ns
T <sub>PERIODAbs</sub>	Spread Disabled PCIF/PCI Period	Measurement at 1.5V	29.49100	30.50900	ns
T <sub>PERIODSSAbs</sub>	Spread Enabled PCIF/PCI Period, SSC	Measurement at 1.5V	29.49100	30.65980	ns
T <sub>HIGH</sub>	PCIF and PCI high time	Measurement at 2.4V	12.0	–	ns
T <sub>LOW</sub>	PCIF and PCI low time	Measurement at 0.4V	12.0	–	ns
Edge Rate	Rising edge rate	Measured between 0.8V and 2.0V	1.0	4.0	V/ns
Edge Rate	Falling edge rate	Measured between 0.8V and 2.0V	1.0	4.0	V/ns

**AC Electrical Specifications** (continued)

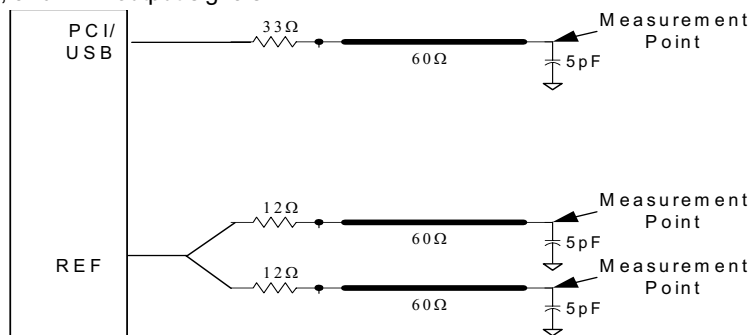
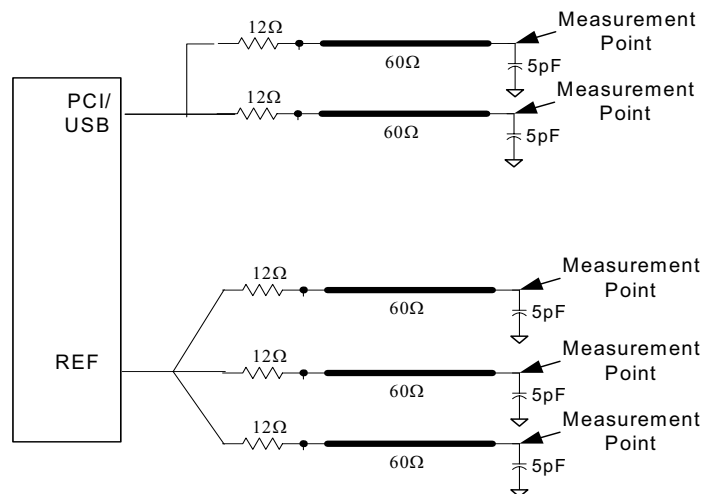
Parameter	Description	Condition	Min.	Max.	Unit
T <sub>SKEW</sub>	Any PCI clock to Any PCI clock Skew	Measurement at 1.5V	–	500	ps
T <sub>CCJ</sub>	PCIF and PCI Cycle to Cycle Jitter	Measurement at 1.5V	–	500	ps
<b>DOT</b>					
T <sub>DC</sub>	DOT96T and DOT96C Duty Cycle	Measured at crossing point V <sub>OX</sub>	45	55	%
T <sub>PERIOD</sub>	DOT96T and DOT96C Period	Measured at crossing point V <sub>OX</sub>	10.41354	10.41979	ns
T <sub>PERIODAbs</sub>	DOT96T and DOT96C Absolute Period	Measured at crossing point V <sub>OX</sub>	10.16354	10.66979	ns
T <sub>CCJ</sub>	DOT96T/C Cycle to Cycle Jitter	Measured at crossing point V <sub>OX</sub>	–	250	ps
L <sub>ACC</sub>	DOT96T/C Long Term Accuracy	Measured at crossing point V <sub>OX</sub>	–	100	ppm
T <sub>LTJ</sub>	Long Term jitter	Measurement taken from cross point V <sub>OX</sub> @ 1 μs	–	700	ps
		Measurement taken from cross point V <sub>OX</sub> @ 10 μs	–	700	ps
T <sub>R</sub> / T <sub>F</sub>	DOT96T and DOT96C Rise and Fall Times	Measured from V <sub>OL</sub> = 0.175 to V <sub>OH</sub> = 0.525V	130	700	ps
T <sub>RFM</sub>	Rise/Fall Matching	Determined as a fraction of 2*(T <sub>R</sub> – T <sub>F</sub> )/(T <sub>R</sub> + T <sub>F</sub> )	–	20	%
ΔT <sub>R</sub>	Rise Time Variation		–	125	ps
ΔT <sub>F</sub>	Fall Time Variation		–	125	ps
V <sub>HIGH</sub>	Voltage High	Math averages <i>Figure 10</i>	660	850	mV
V <sub>LOW</sub>	Voltage Low	Math averages <i>Figure 10</i>	–150	–	mV
V <sub>OX</sub>	Crossing Point Voltage at 0.7V Swing		250	550	mV
V <sub>OVS</sub>	Maximum Overshoot Voltage		–	V <sub>HIGH</sub> + 0.3	V
V <sub>UDS</sub>	Minimum Undershoot Voltage		–0.3	–	V
V <sub>RB</sub>	Ring Back Voltage	See <i>Figure 10</i> . Measure SE	–	0.2	V
<b>USB48, 24_48M</b>					
T <sub>DC</sub>	USB Duty Cycle	Measurement at 1.5V	45	55	%
T <sub>PERIOD</sub>	USB Period,	Measurement at 1.5V, mean value over 1 μs	20.83125	20.83542	ns
T <sub>PERIODAbs</sub>	USB Period	Measurement at 1.5V, max. and min. values over 1 μs	20.48125	21.18542	ns
T <sub>PERIOD24</sub>	24M Period	Measurement at 1.5V, mean value over 1 μs	41.67083	41.66250	ns
T <sub>PERIOD24Abs</sub>	24M Period	Measurement at 1.5V, max. and min. values over 1 μs	41.57083	41.76250	ns
L <sub>ACC</sub>	Long Accuracy	Measured at 1.5V using frequency counter over 0.15s	–	100	ppm
T <sub>HIGH</sub>	USB high time (High drive)	Measurement at 2.0V	8.094	10.9	ns
T <sub>LOW</sub>	USB low time (High drive)	Measurement at 0.8V	7.694	11.5	ns
T <sub>HIGH24</sub>	USB high time (High drive)	Measurement at 2.0V	16.188	22.7	ns
T <sub>LOW24</sub>	USB low time (High drive)	Measurement at 0.8V	15.388	22.6	ns
Edge rate	Rising edge rate (High drive)	Measured between 0.8V and 2.0V	1.0	3.0	V/ns
Edge rate	Falling edge rate (High drive)	Measured between 0.8V and 2.0V	1.0	3.0	V/ns
T <sub>CCJ</sub>	USB Cycle to Cycle Jitter (High drive)	Measurement taken@1.5V waveform	–	300	ps
	24_48M Cycle to Cycle Jitter (High drive)	Measurement taken@1.5V waveform	–	350	ps
T <sub>LTJ</sub>	Long Term jitter	Measurement taken from cross point V <sub>OX</sub> @ 1 μs	–	700	ps

**AC Electrical Specifications** (continued)

Parameter	Description	Condition	Min.	Max.	Unit
$T_{LTJ}$	Long Term jitter	Measurement taken from cross point $V_{OX}$ @ 10 $\mu$ s	–	700	ps
$T_{LTJ}$	Long Term jitter	Measurement taken from cross point $V_{OX}$ @ 125 $\mu$ s	–	700	ps
<b>REF</b>					
$T_{DC}$	REF Duty Cycle	Measurement at 1.5V	45	55	ns
$T_{PERIOD}$	REF Period	Measurement at 1.5V	69.8203	69.8622	ns
$T_{PERIODAbs}$	REF Absolute Period	Measurement at 1.5V	68.82033	70.86224	ns
Edge Rate	Rising edge rate	Measured between 0.8V and 2.0V	1.0	4.0	V/ns
Edge Rate	Falling edge rate	Measured between 0.8V and 2.0V	1.0	4.0	V/ns
$T_{CCJ}$	REF Cycle to Cycle Jitter	Measurement at 1.5V	–	1000	ps
<b>ENABLE/DISABLE and SET-UP</b>					
$T_{STABLE}$	Clock Stabilization from Power-up		–	1.8	ms

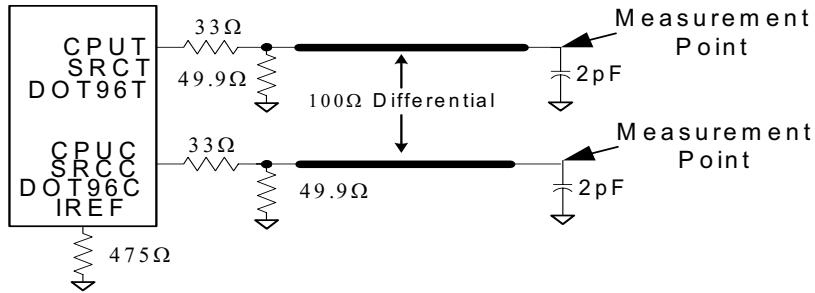
**Test and Measurement Set-up**
**For PCI Single-ended Signals and Reference**

The following diagrams show the test load configurations for the single-ended PCI, USB, and REF output signals.

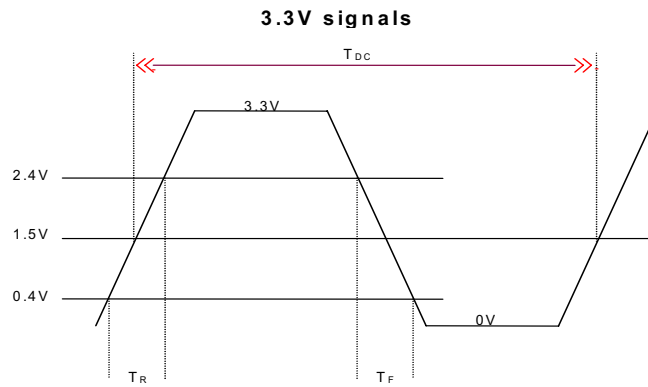

**Figure 8. Single-ended Load Configuration**

**Figure 9. Single-ended Load Configuration HIGH DRIVE OPTION**

### For Differential CPU, SRC and DOT96 Output Signals

The following diagram shows the test load configuration for the differential CPU and SRC outputs.



**Figure 10. 0.7V Single-ended Load Configuration**



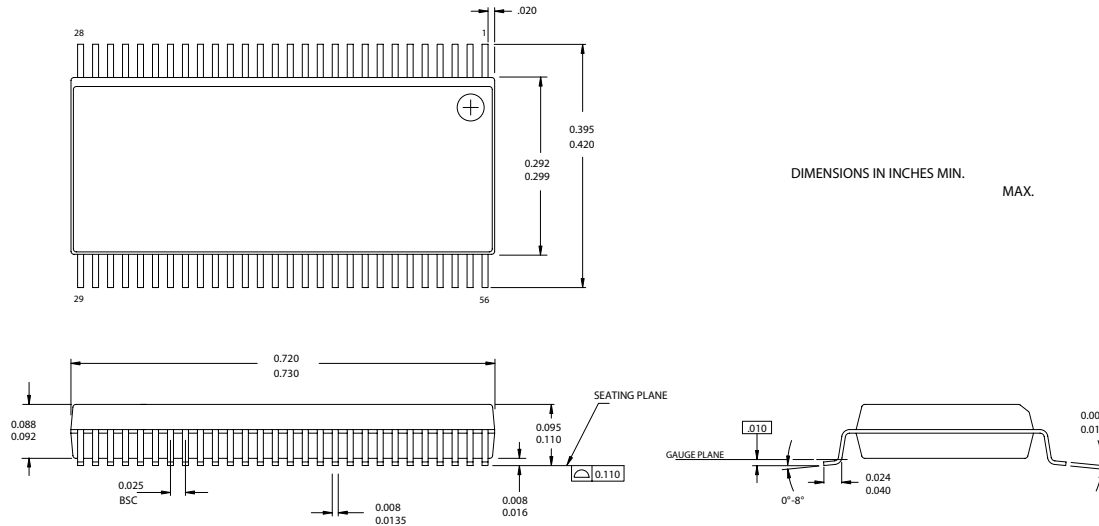
**Figure 11. Single-ended Output Signals (for AC Parameters Measurement)**

### Ordering Information

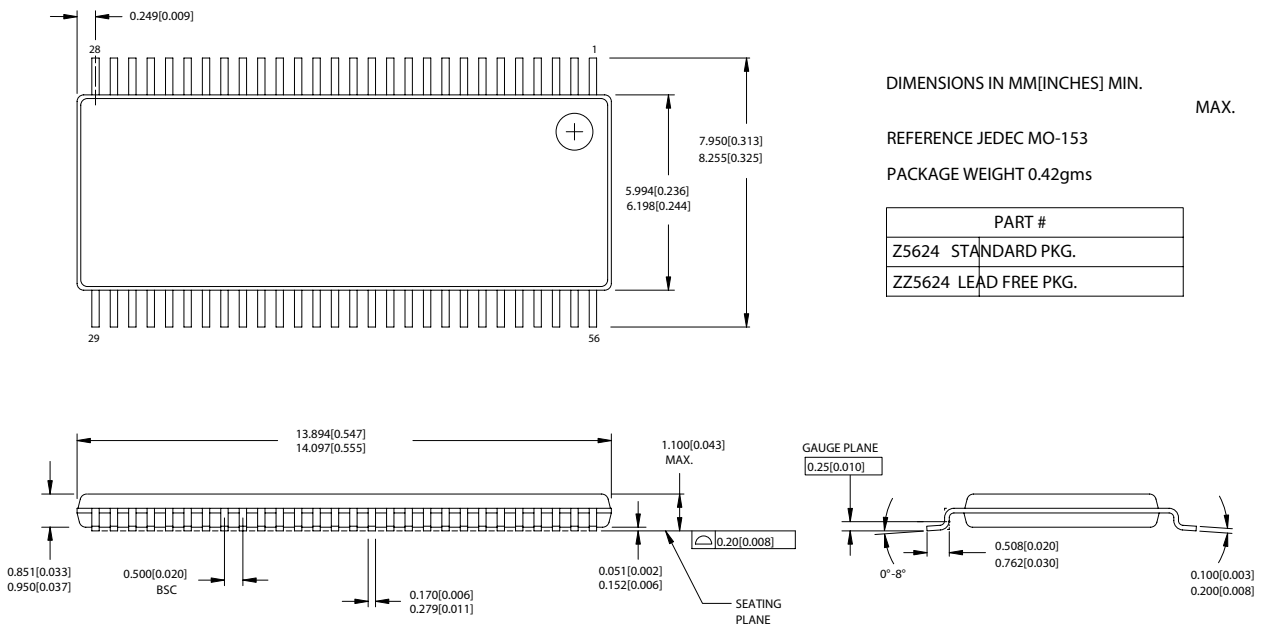
Part Number	Package Type	Product Flow
<b>Lead-free</b>		
CY28439OXC-2	56-pin SSOP	Commercial, 0° to 85°C
CY28439OXC-2T	56-pin SSOP – Tape and Reel	Commercial, 0° to 85°C
CY28439ZXC-2	56-pin TSSOP	Commercial, 0° to 85°C
CY28439ZXC-2T	56-pin TSSOP – Tape and Reel	Commercial, 0° to 85°C

### Package Drawing and Dimensions

#### 56-Lead Shrunk Small Outline Package O56



#### 56-Lead Thin Shrunk Small Outline Package, Type II (6 mm x 12 mm) Z56



While SLI has reviewed all information herein for accuracy and reliability, Spectra Linear Inc. assumes no responsibility for the use of any circuitry or for the infringement of any patents or other rights of third parties which would result from each use. This product is intended for use in normal commercial applications and is not warranted nor is it intended for use in life support, critical medical instruments, or any other application requiring extended temperature range, high reliability, or any other extraordinary environmental requirements unless pursuant to additional processing by Spectra Linear Inc., and expressed written agreement by Spectra Linear Inc. Spectra Linear Inc. reserves the right to change any circuitry or specification without notice.