

Application Note

AN2201/D
Rev. 0, 11/2001

*Low Battery Cranking Pulse in
Automotive Applications*



by Axel Bahr
Motorola Field Applications Engineering
Munich, Germany

1 Introduction

Electronic modules in automotive applications have to withstand the environmental conditions in the car. These can be separated into mechanical stresses, for example, vibrations, temperature or humidity, and electrical stresses that are applied to the module.

This application note gives some more detailed information specifically about significant voltage drops of the car's battery.

2 Cranking Pulse

Huge voltage drops can occur when certain events happen together, for example, a discharged battery, low temperatures and the driver attempting to start up the car.

This situation has been termed 'cranking pulse' by car manufacturers. Although different car manufacturers might have different voltage values defined in their cranking pulse specification, the shape of the voltage dropping down and recovering can be described by [Figure 1](#).

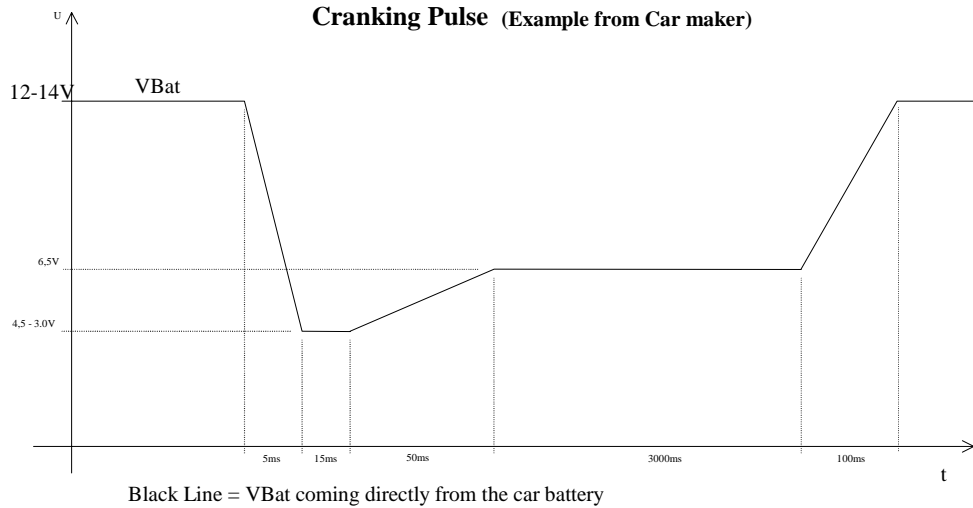

Figure 1

A simplified power supply for any application might look as shown in **Figure 2**. A reverse battery protection diode feeds the Vbat from the battery into the voltage regulator (with integrated reset circuitry), which then supplies the MCU.

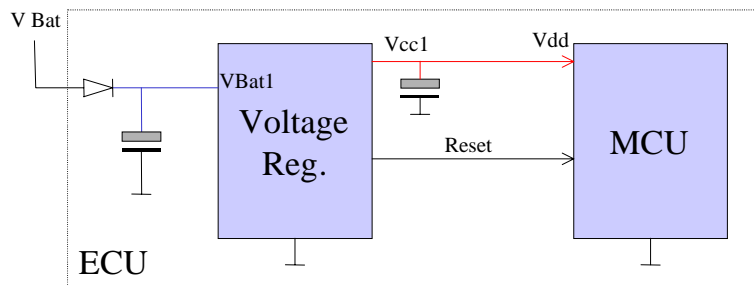

Figure 2

This schematic, applied to the cranking pulse from **Figure 1**, shows the areas where problems are likely to occur (**Figure 3**).

Note that the absolute shape of the voltages Vbat, Vbat1 and Vdd can look different from application to application due to combinations of voltage regulator specifications and the surrounding components, but the overall desired result is still the same; the module must not exhibit uncontrolled behavior.

In some non-critical systems, it is often enough to make sure that the MCU is being put into proper reset that keeps the application under control. Still, with the rising complexity and increase of networking in the car, the desire is to finish the ongoing communication with other modules before the application ceases to work. Furthermore, it is not enough to simply reboot the system – data must be stored safely while the MCU is unable to work.

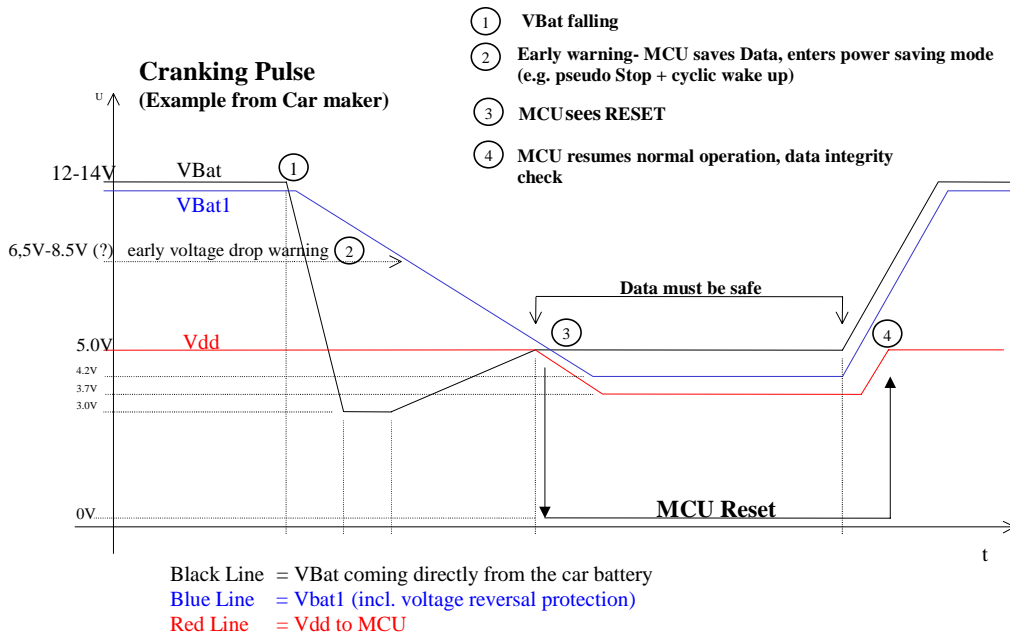

Figure 3

1. **VBat falling**

Note that there is a difference between the VBat (actual Battery Voltage) and VBat1 (reduced by a Diode and buffered by a Capacitor)

2. **Early warning**

MCU realizes that the Module supply is breaking down --> MCU saves data and enters power saving mode
(Example: Pseudo Stop + cyclic wake up, thus the MCU can monitor the voltage and can resume work when the voltage is rising again without going through reset)

3. **MCU sees RESET**

As the voltage is dropping further down, the MCU is being put in reset state

Note that this also puts all I/Os and registers in predefined states.

4. **MCU resumes normal operation, PORF check**

The MCU voltage is high enough to allow the MCU to operate properly, so reset is being removed. The MCU software may check the power on flag (PORF) which indicates whether the RAM data integrity is good or a complete initialization sequence is needed.

NOTE: *Provided an appropriate external reset signal is applied to the MCU, preventing the CPU from executing code when VDD5 is out of specification limits, the SRAM content's integrity is guaranteed, if after a reset has occurred, the PORF bit in the CRG flags register has not been set (taken from HCS12 Specification).*

Figure 4 shows a possible power supply for the module, utilizing the advantages of the Motorola system basis chip (SBC) MC33389 in combination with a member of the HCS12 family, the latest Motorola 16-Bit Microcontrollers (for example, the MC9S12DP256).

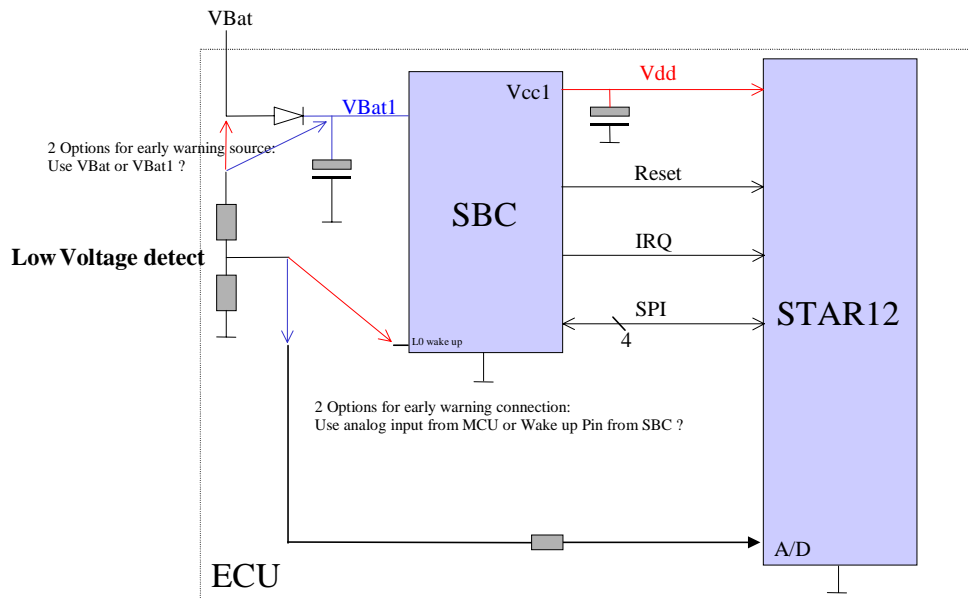

Figure 4

NOTE: The MC33389 SBC offers additional advantages, such as the integrated CAN physical interface, a second MCU power supply, an external watchdog functionality and high voltage key wake up ports. This is not shown here. Please refer to the data book of the SBC MC33389 for detailed information.

Table 1 suggests different ways to create early warning options.

Table 1 Early Warning Options

Source	Connection	Remarks
VBat1	SBC	Causes interrupt when early warning occurs, therefore usable when MCU is in STOP mode, but less accuracy for measurement
VBat1	HCS12 ATD	Higher measurement accuracy, but SW effort required to detect early warning, more effort required to detect early warning when MCU is in STOP
VBat	SBC	May give many early warning interrupts due to spikes on VBat
VBat	HCS12 ATD	May give many early warning interrupts due to spikes on VBat, also problems with protection of ATD input (reverse polarity, over voltage)

3 Conclusion

The HCS12 and the SBC are well suited to cope with automotive conditions. Using this kind of system approach for the development, the user can save on costs for external circuitry, while gaining an integrated 'toolkit' to fulfill the car manufacturer's requirements.

4 Data Sources and WEB pages

Motorola Parts search engine:

http://e-www.motorola.com/webapp/sps/library/prod_lib.jsp

MCU Literature (App Notes, Data Books, Reference Manuals):

http://e-www.motorola.com/webapp/sps/library/docu_lib.jsp

MCU 3rd Party Tools (search engine for Compiler / Emulators / etc):

http://www.motorola.com/mcu/dev_tools/3rd/index.html

Freescale Semiconductor, Inc.

HOW TO REACH US:

USA/EUROPE/LOCATIONS NOT LISTED:

Motorola Literature Distribution;
P.O. Box 5405, Denver, Colorado 80217
1-303-675-2140 or 1-800-441-2447

JAPAN:

Motorola Japan Ltd.; SPS, Technical Information Center,
3-20-1, Minami-Azabu Minato-ku, Tokyo 106-8573 Japan
81-3-3440-3569

ASIA/PACIFIC:

Motorola Semiconductors H.K. Ltd.;
Silicon Harbour Centre, 2 Dai King Street,
Tai Po Industrial Estate, Tai Po, N.T., Hong Kong
852-26668334

TECHNICAL INFORMATION CENTER:

1-800-521-6274

HOME PAGE:

<http://www.motorola.com/semiconductors>

Information in this document is provided solely to enable system and software implementers to use Motorola products. There are no express or implied copyright licenses granted hereunder to design or fabricate any integrated circuits or integrated circuits based on the information in this document.

Motorola reserves the right to make changes without further notice to any products herein. Motorola makes no warranty, representation or guarantee regarding the suitability of its products for any particular purpose, nor does Motorola assume any liability arising out of the application or use of any product or circuit, and specifically disclaims any and all liability, including without limitation consequential or incidental damages. "Typical" parameters which may be provided in Motorola data sheets and/or specifications can and do vary in different applications and actual performance may vary over time. All operating parameters, including "Typicals" must be validated for each customer application by customer's technical experts. Motorola does not convey any license under its patent rights nor the rights of others. Motorola products are not designed, intended, or authorized for use as components in systems intended for surgical implant into the body, or other applications intended to support or sustain life, or for any other application in which the failure of the Motorola product could create a situation where personal injury or death may occur. Should Buyer purchase or use Motorola products for any such unintended or unauthorized application, Buyer shall indemnify and hold Motorola and its officers, employees, subsidiaries, affiliates, and distributors harmless against all claims, costs, damages, and expenses, and reasonable attorney fees arising out of, directly or indirectly, any claim of personal injury or death associated with such unintended or unauthorized use, even if such claim alleges that Motorola was negligent regarding the design or manufacture of the part.



Motorola and the Stylized M Logo are registered in the U.S. Patent and Trademark Office. digital dna is a trademark of Motorola, Inc. All other product or service names are the property of their respective owners. Motorola, Inc. is an Equal Opportunity/Affirmative Action Employer.

© Motorola, Inc. 2001

AN2201/D

**For More Information On This Product,
Go to: www.freescale.com**