

## Dimmer

**BTS 629**  
**BTS 629 A**

The device allows continuous control of power to a lamp or LED load utilizing pulse-width-modulation.

### Features

- High-side switch
- Overtemperature protection
- Short circuit / Overload protection through pulse width reduction and overtemperature shutdown
- Load dump protection up to 93.5 V <sup>1)</sup>
- Undervoltage and overvoltage shutdown with auto-restart and hysteresis
- Reverse battery protection <sup>1)</sup>
- Timing frequency adjustable
- Controlled switching rise and fall times
- Minimized Radio Frequency Interferences (RFI)
- Maximum current internally limited
- Protection against loss of signal GND <sup>2)</sup>
- Electrostatic discharge (ESD) protection
- Package: TO-220/7 and SMD, Pin 4 is shorted to the tab

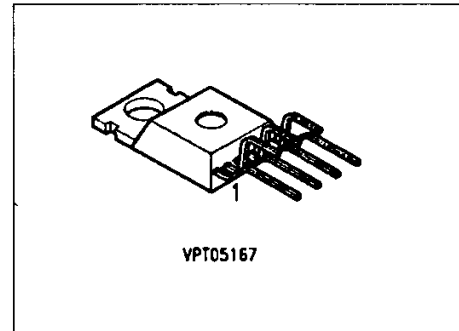

### Note:

Switching frequency is programmed with an external capacitor. To assist with accurate setting of this parameter the dimmer is factory selected into two groups (see page 8). For large quantity orders, customer will need to be prepared to accept deliveries of both groups.

Type	Ordering code	Package
BTS 629	C67078-S5501-A2	TO-220/7
BTS 629 A	C67078-S5501-A5	TO-220/7

### Maximum Ratings

Parameter	Symbol	Value	Unit
Active overvoltage protection	$V_{bb(AZ)}$	> 50	V
Short-circuit current	$I_{SC}$	self-limited	-
Operating temperature range	$T_j$	- 40 ... + 150	°C
Storage temperature range	$T_{stg}$	- 55 ... + 150	
Power dissipation, $T_c = 25\text{ °C}$	$P_{tot}$	75	W
Thermal resistance			K/W
Chip - case	$R_{thJC}$	≤ 1.67	
Chip - ambient	$R_{thJA}$	≤ 75	

<sup>1)</sup> With 150 Ω resistor in Signal GND connection

<sup>2)</sup> Potential between Signal GND and Load GND > 0.5 V

**Blockdiagram**

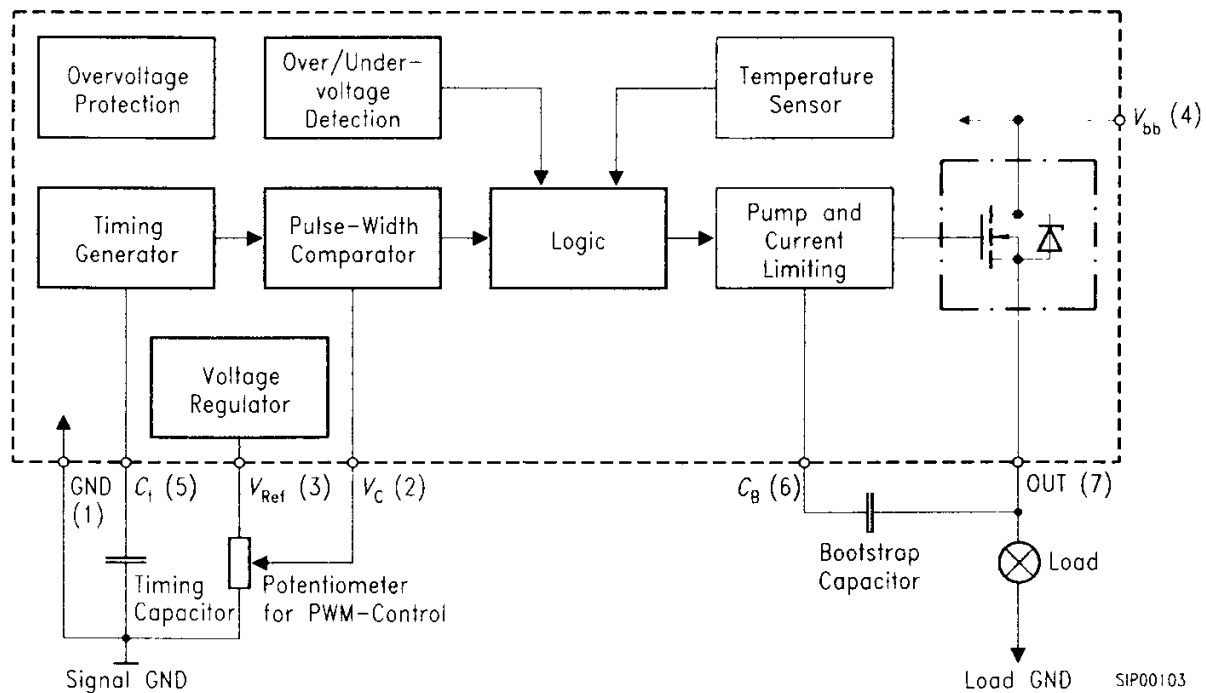

**Electrical Characteristics**

at  $T_j = 25\text{ °C}$ , unless otherwise specified.

Parameter	Symbol	Values			Unit
		min.	typ.	max.	
On-state resistance (pin 4 to 7) $I_L = 2\text{ A}$ , $V_{bb} = 12\text{ V}$	$R_{on}$	-	160	180	mΩ
Operating voltage (pin 4 to GND) $T_j = +25 \dots +150\text{ °C}$ $T_j = -40 \dots +150\text{ °C}$	$V_{bb}$	5.5 <sup>1)</sup> 5.9	-	16.9 <sup>2)</sup> 16.9	V
Nominal current, calculated value (pin 4 to 7) ISO-proposal: $V_{bb} - V_{out} \leq 0.5\text{ V}$ , $T_C = 85\text{ °C}$	$I_L\text{-ISO}$	-	-	2.0	A
Load current, theoretical value (pin 4 to 7) MOS-standard: $T_C = 25\text{ °C}$ , $T_j = 150\text{ °C}$	$I_L\text{-MOS}$	-	-	14	A
Load current limit (pin 4 to 7) $V_{bb} - V_{out} > 1\text{ V}$	$I_{LLim}$	-	12	-	A
Undervoltage threshold (Pin 4 to GND) $R_L = 6\text{ Ω}$	$V_{bb(Low)}$	3.0	4.2	5.4	V
Overvoltage threshold (Pin 4 to GND) $R_L = 6\text{ Ω}$	$V_{bb(HI)}$	17.0	17.8	18.6	V

<sup>1)</sup> Note: undervoltage shutdown

<sup>2)</sup> Note: overvoltage shutdown

**Electrical Characteristics**

at  $T_j = 25\text{ }^\circ\text{C}$ , unless otherwise specified.

Parameter	Symbol	Values			Unit
		min.	typ.	max.	
PWM reduction threshold (pin 4 to GND), $R_L = 6\ \Omega$	$V_{bb}$	12.6	13.9	14.1	V
Max. output voltage (RMS) (pin 7 to GND), $R_L = 6\ \Omega$	$V_{RMSmax}$	12.2	13.5	13.7	
Reference voltage (pin 3 to pin 1) $V_{bb} = 12\text{ V}$ , $I_{REF} = 10\text{ mA}$	$V_{REF}$	2.0	2.5	3.0	
Reference current (pin 3 to pin 1) $V_{bb} = 12\text{ V}$ , pin 3 to 1 short	$I_{REF}$	–	150	–	mA
Internal current consumption during operation (pin 4 to pin 1, measured in PWM gap) $V_{bb} = 12\text{ V}$ , R pin 3 to GND = $2.5\text{ k}\Omega$	$I_R$	–	2.0	3.5	
Bootstrap voltage (pin 6 to pin 7) $V_{bb} = 12\text{ V}$	$V_B$	–	10	–	V
PWM frequency (pin 7 to GND) $V_{bb} = 12\text{ V}$ , $T_C = -40 \dots +130\text{ }^\circ\text{C}$ BTS 629 $C_t = 47\text{ nF}$ BTS 629 A $C_t = 68\text{ nF}$	$f_{PWM}$	60	–	120	Hz
Max. pulse duty factor $V_{bb} = 12\text{ V}$ , $R_L = 6\ \Omega$ , $V_C = V_{REF}$ (50% $V_{out}$ )	$D_{fmax}$	95	98	–	%
Min. pulse duty factor $V_{bb} = 12\text{ V}$ , $R_L = 6\ \Omega$ , $V_C = 0$ (50% $V_{out}$ )	$D_{fmin}$	–	8	14	
Slew rate "on" $V_{bb} = 12\text{ V}$ , $R_L = 6\ \Omega$ , 10...30% $V_{out}$	$dv/dt_{(on)}$	–	–	0.12	V/ $\mu\text{s}$
Slew rate "off" $V_{bb} = 12\text{ V}$ , $R_L = 6\ \Omega$ , 90...10% $V_{out}$	$dv/dt_{(off)}$	–	–	0.12	
Slew rate "on" $V_{bb} = 12\text{ V}$ , $R_L = 6\ \Omega$ , 10...30% $I_{out}$	$di/dt_{(on)}$	–	–	0.02	A/ $\mu\text{s}$
Slew rate "off" $V_{bb} = 12\text{ V}$ , $R_L = 6\ \Omega$ , 90...10% $I_{out}$	$di/dt_{(off)}$	–	–	0.02	
Thermal overload trip temperature	$T_{jt}$	150	–	–	$^\circ\text{C}$

**Circuits**

**Analog Logic-Input  $V_C$  (2)**

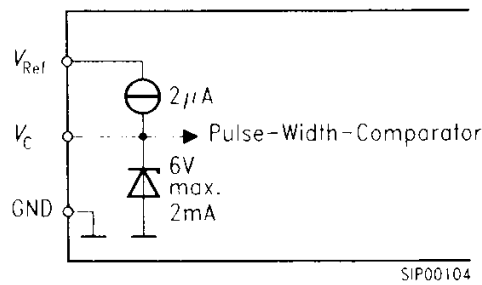

**Triangular wave form Generator Input  $C_t$  (5)**

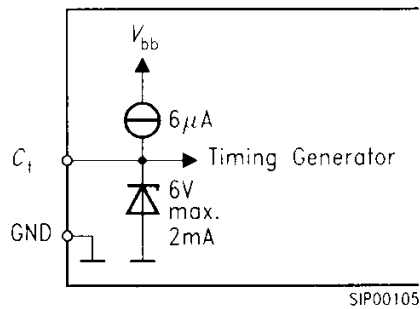

**Voltage Sensor (typ)**

Undervoltage sensor

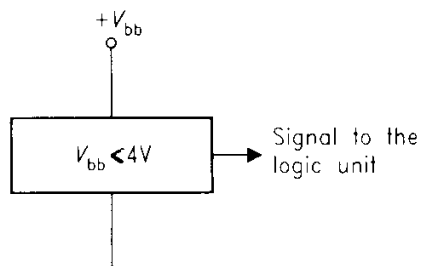

Overvoltage sensor

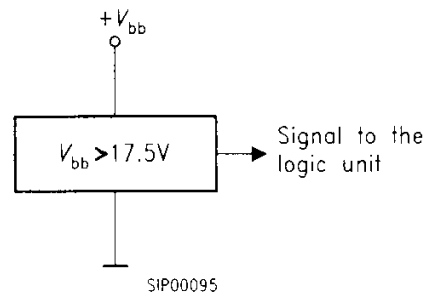

**Operating range (typ.)**

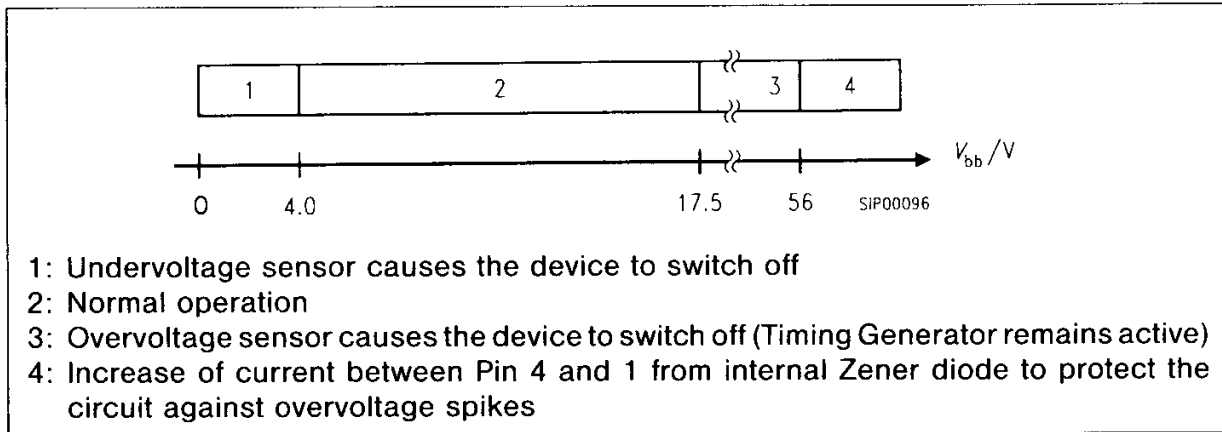

**Susceptibility to electrical interference to DIN 40 839 part 1 (12 V supply voltage)\***

Test pulse	Susceptibility levels							
					with 150 Ω in GND-line			
	I	II	III	IV	I	II	III	IV
1	X	X	X	X	X	X	X	X
2	X	X	Y	Y	X	X	X	X
3a	X	X	X	X	X	X	X	X
3b	X	X	X	X	X	X	X	X
4	X	X	X	X	X	X	X	X
5	X	X	Y	Y	X	X	X	Y

**Class X:** All functions of the device are performed as designed after exposure to disturbance

**Class Y:** One or more functions of the device are not performed as designed after exposure and cannot be returned to proper operation without replacing the device

**Test pulse 5: Load dump**

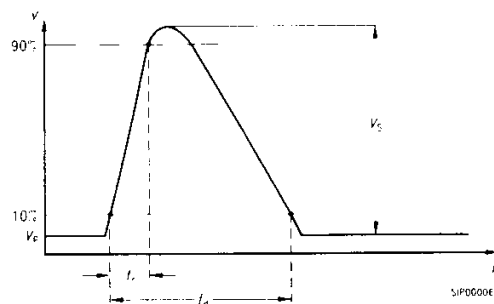

Parameters:  $V_S = 50 \text{ V}$  (level II)  
 $V_P = 13.5 \text{ V}$   
 $R_i = 0.5 \text{ to } 4 \text{ } \Omega$   
 $t_d = 40 \text{ to } 400 \text{ ms}$   
 $t_r = 0.1 \text{ to } 10 \text{ ms}$

$I_{Load}$  (Pin 7 to GND) =  $I_L$ -ISO (see page 2)  
 with 150 Ω in GND-line:  
 $V_S = 80 \text{ V}$  (Level III)

**Note:**  
 The condition are related to each other in that the high setting values of  $V_S$ ,  $R_i$  and  $t_d$  belong together as do respectively the low values

\*) DIN 40839: Electromagnetic compatibility (EMC) in motor vehicles; correlation with ISO-Technical Report 7637/0 and 7637/1.

**Susceptibility to electrical interference**  
to DIN 40 839 part 1 (12 V supply voltage)

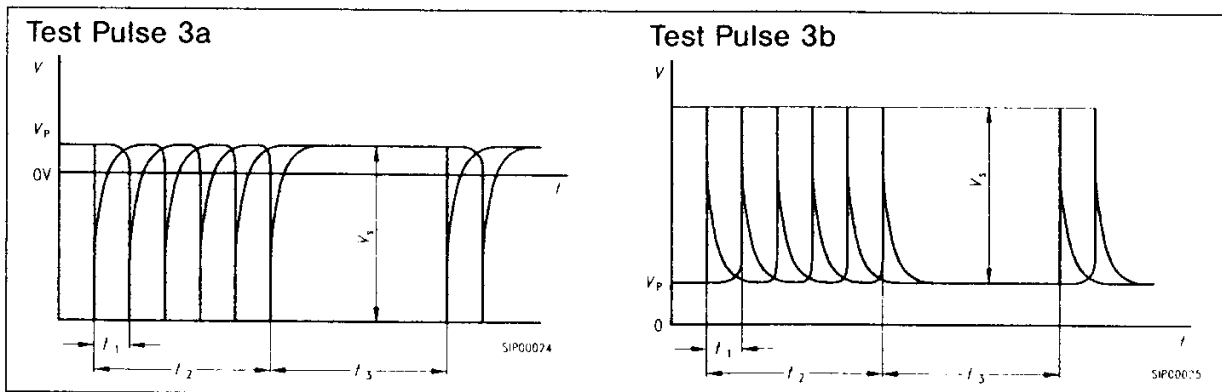

**Parameters**  
 $V_S = -150 \text{ V}$   
 $R_i = 50 \ \Omega$   
 $t_d = 0.1 \ \mu\text{s}$   
 $t_r = 5 \text{ ns}$   
 $t_1 = 100 \ \mu\text{s}$   
 $t_2 = 10 \text{ ms}$   
 $t_3 = 90 \text{ ms}$

**Parameters**  
 $V_S = 100 \text{ V}$   
 $R_i = 50 \ \Omega$   
 $t_d = 0.1 \ \mu\text{s}$   
 $t_r = 5 \text{ ns}$   
 $t_1 = 100 \ \mu\text{s}$   
 $t_2 = 10 \text{ ms}$   
 $t_3 = 90 \text{ ms}$

**Test circuit**

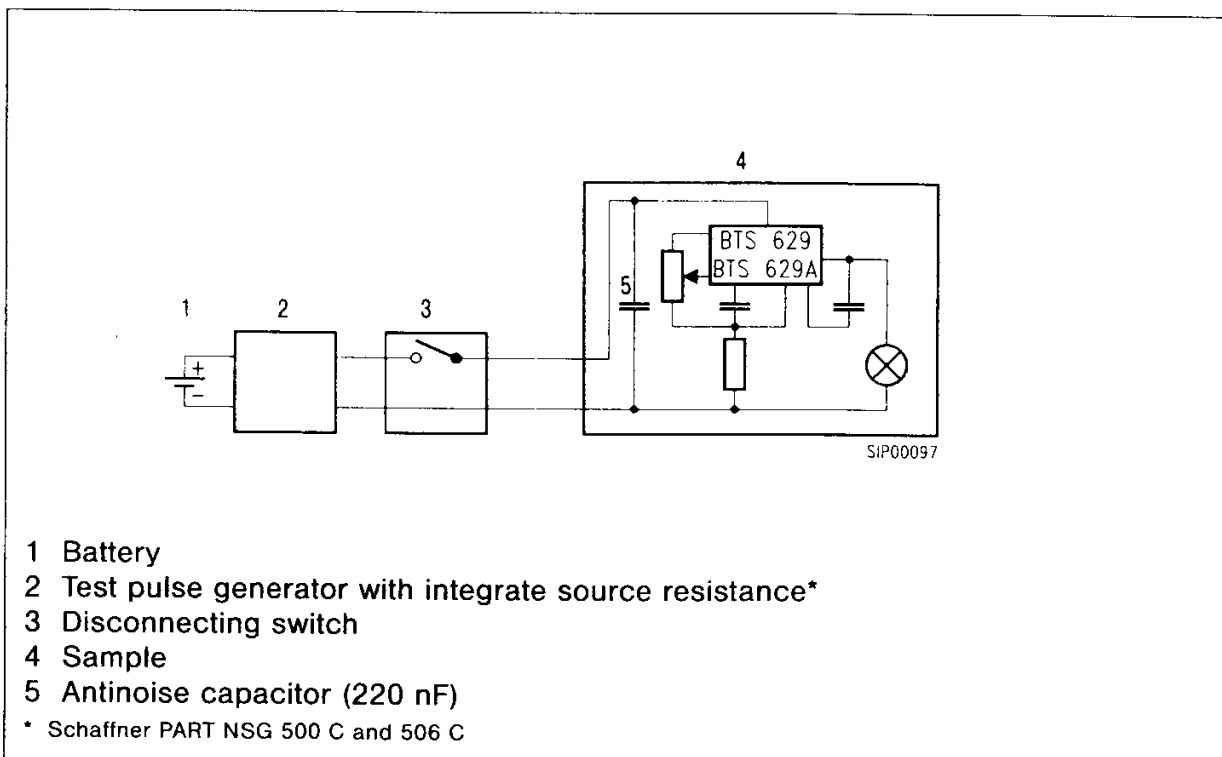

**Applications**

**Dimming of dashboard lighting**

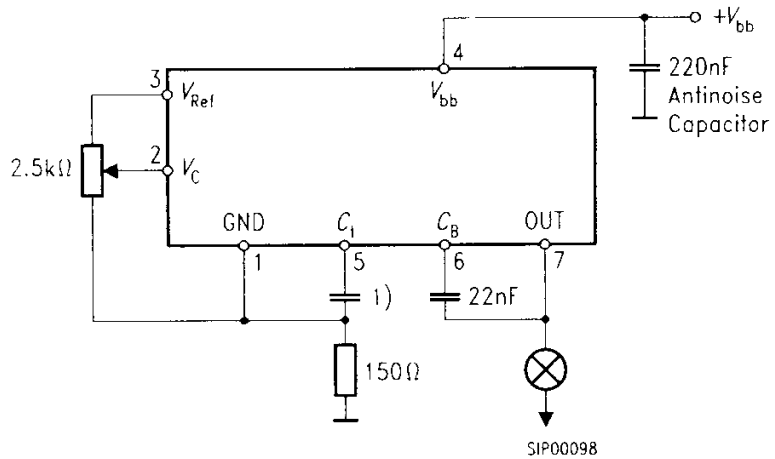

1) BTS 629  $C_1 = 47 \text{ nF}$   
BTS 629 A  $C_1 = 68 \text{ nF}$

Resistor for  
reverse battery and load dump  
protection

**Maximum Brightness**

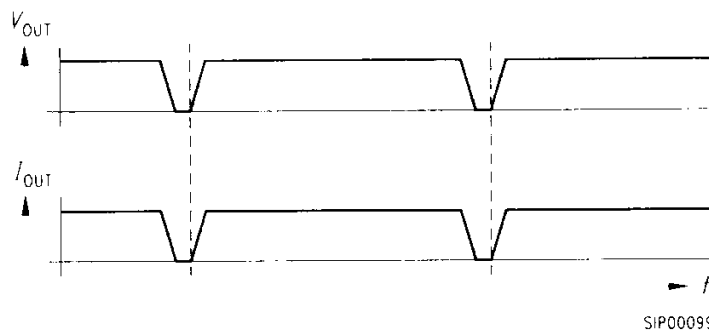

**Minimum Brightness**

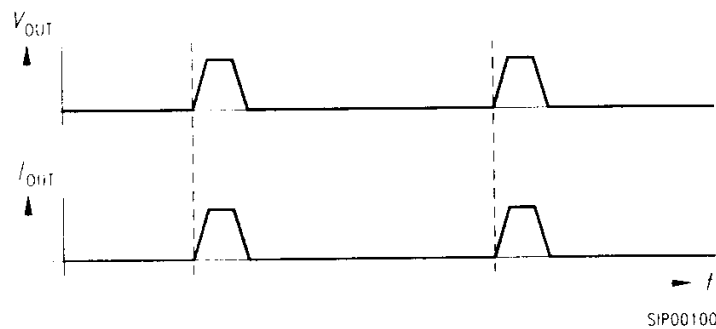

**BTS 629**  
**PWM Frequency characteristic**  
**min./max. Values**

$C_t = 47 \text{ nF}$                        $V_{bb} = 12 \text{ V}$   
 $Q_c \geq 500 / f = 10 \text{ kHz}$     $C_B = 22 \text{ nF}$

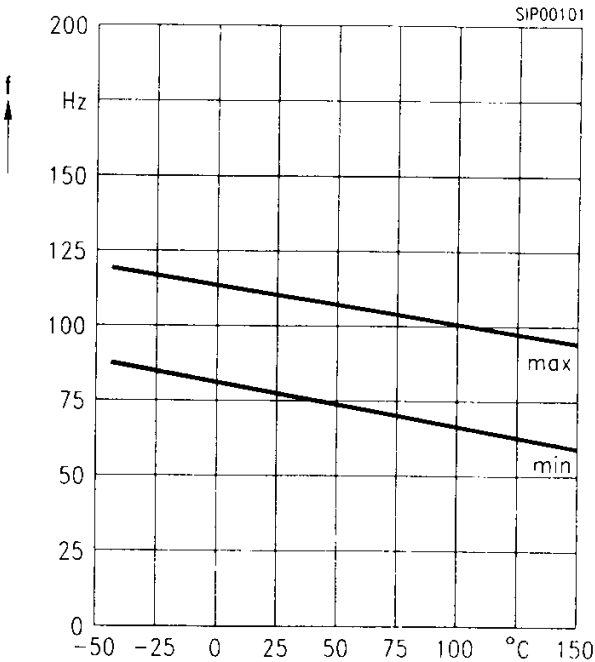

**BTS 629A**  
**PWM Frequency characteristic**  
**min./max. Values**

$C_t = 68 \text{ nF}$                        $V_{bb} = 12 \text{ V}$   
 $Q_c \geq 500 / f = 10 \text{ kHz}$     $C_B = 22 \text{ nF}$

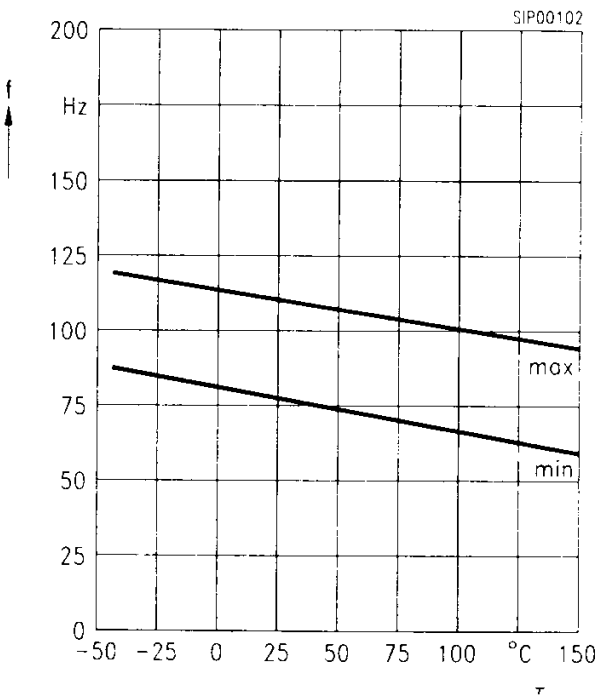



**Package**  
 TO-220/7  
 Weight: 0.5 g  
 Dimensions in mm

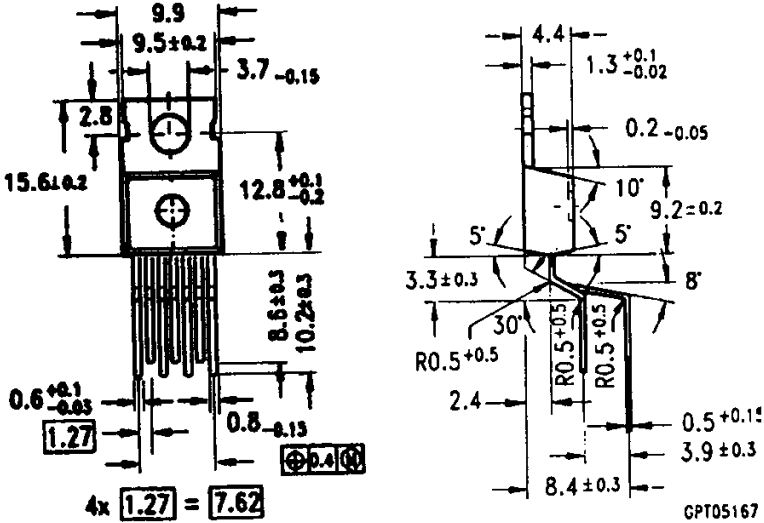

CPT05167

Pin	1	2	3	4	5	6	7
	GND	V <sub>c</sub>	V <sub>REF</sub>	V <sub>bb</sub>	C <sub>t</sub>	C <sub>B</sub>	OUT

