

Smart Two Channel Highside Power Switch

Features

- Overload protection
- Current limitation
- Short circuit protection
- Thermal shutdown
- Overvoltage protection (including load dump)
- Reverse battery protection¹⁾
- Undervoltage and overvoltage shutdown with auto-restart and hysteresis
- Open drain diagnostic output
- Open load detection in ON-state
- CMOS compatible input
- Loss of ground and loss of V_{bb} protection
- Electrostatic discharge (ESD) protection

Application

- μ C compatible power switch with diagnostic feedback for 12 V DC grounded loads
- Most suitable for resistive and lamp loads

Product Summary

Overvoltage protection	$V_{bb(AZ)}$	43	V	
Operating voltage	$V_{bb(on)}$	5.0 ... 24	V	
	channels:	each	both parallel	
On-state resistance	R_{ON}	200	100	m Ω
Load current (ISO)	$I_{L(ISO)}$	2.3	4.4	A
Current limitation	$I_{L(SCI)}$	5	5	A

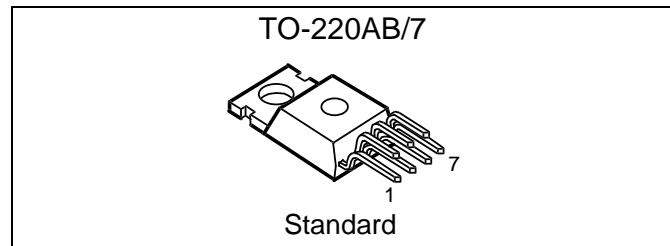

General Description

N channel vertical power FET with charge pump, ground referenced CMOS compatible input and diagnostic feedback, monolithically integrated in Smart SIPMOS® technology. Fully protected by embedded protection functions.

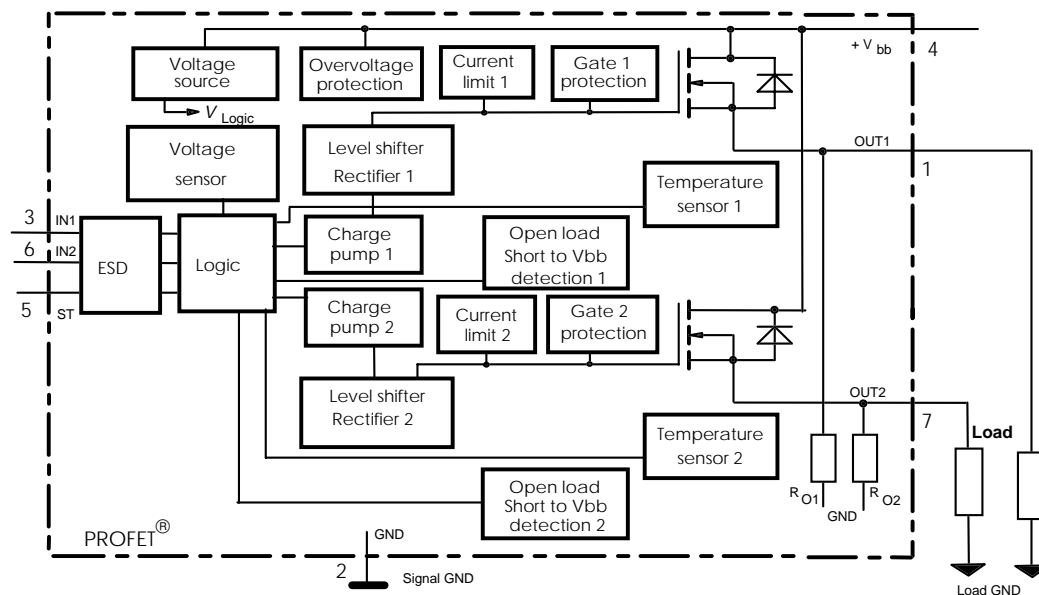

1) With external current limit (e.g. resistor $R_{GND}=150 \Omega$) in GND connection, resistor in series with ST connection, reverse load current limited by connected load.

Pin	Symbol	Function
1	OUT1 (Load, L)	Output 1, protected high-side power output of channel 1
2	GND	Logic ground
3	IN1	Input 1, activates channel 1 in case of logical high signal
4	V _{bb}	Positive power supply voltage, the tab is shorted to this pin
5	ST	Diagnostic feedback: open drain, low on failure
6	IN2	Input 2, activates channel 2 in case of logical high signal
7	OUT2 (Load, L)	Output 2, protected high-side power output of channel 2

Maximum Ratings at $T_j = 25\text{ °C}$ unless otherwise specified

Parameter	Symbol	Values	Unit
Supply voltage (overvoltage protection see page 3)	V_{bb}	43	V
Supply voltage for full short circuit protection $T_{j\text{ start}} = -40 \dots +150\text{ °C}$	V_{bb}	24	V
Load dump protection ²⁾ $V_{\text{LoadDump}} = U_A + V_S$, $U_A = 13.5\text{ V}$ $R_I^3) = 2\ \Omega$, $R_L = 5.3\ \Omega$, $t_d = 200\text{ ms}$, IN= low or high	$V_{\text{Load dump}}^4)$	60	V
Load current (Short circuit current, see page 4)	I_L	self-limited	A
Operating temperature range	T_j	-40 ... +150	°C
Storage temperature range	T_{stg}	-55 ... +150	
Power dissipation (DC), $T_C \leq 25\text{ °C}$	P_{tot}	36	W
Electrostatic discharge capability (ESD) (Human Body Model) acc. MIL-STD883D, method 3015.7 and ESD assn. std. S5.1-1993	IN: V_{ESD} all other pins:	1.0 2.0	kV
Input voltage (DC)	V_{IN}	-10 ... +16	V
Current through input pin (DC)	I_{IN}	± 2.0	mA
Current through status pin (DC)	I_{ST}	± 5.0	
see internal circuit diagrams page 6			

Thermal Characteristics

Parameter and Conditions	Symbol	Values			Unit
		min	typ	max	
Thermal resistance chip - case, both channels: each channel:	R_{thJC}	--	--	3.5	K/W
		--	--	7.0	
junction - ambient (free air):	R_{thJA}	--	--	75	

2) Supply voltages higher than $V_{bb(AZ)}$ require an external current limit for the GND and status pins, e.g. with a 150 Ω resistor in the GND connection and a 15 k Ω resistor in series with the status pin. A resistor for the protection of the input is integrated.

3) R_I = internal resistance of the load dump test pulse generator

4) $V_{\text{Load dump}}$ is setup without the DUT connected to the generator per ISO 7637-1 and DIN 40839

Electrical Characteristics

Parameter and Conditions, each channel at $T_j = 25\text{ °C}$, $V_{bb} = 12\text{ V}$ unless otherwise specified	Symbol	Values			Unit
		min	typ	max	

Load Switching Capabilities and Characteristics

On-state resistance (pin 4 to 1 or 7) $I_L = 1.8\text{ A}$ each channel	$T_j = 25\text{ °C}$: $T_j = 150\text{ °C}$:	R_{ON}	--	160 320	200 400	mΩ
Nominal load current, ISO Norm (pin 4 to 1 or 7) $V_{ON} = 0.5\text{ V}$, $T_C = 85\text{ °C}$ each channel: both channels parallel:		$I_{L(ISO)}$	1.8 3.5	2.3 4.4	-- --	A
Output current (pin 1 or 7) while GND disconnected or GND pulled up, $V_{bb} = 30\text{ V}$, $V_{IN} = 0$, see diagram page 7		$I_{L(GNDhigh)}$	--	--	10	mA
Turn-on time IN \square to 90% V_{OUT} :		t_{on}	80	200	400	μs
Turn-off time IN \sqcap to 10% V_{OUT} :		t_{off}	80	200	400	
Slew rate on 10 to 30% V_{OUT} , $R_L = 12\text{ Ω}$, $T_j = -40...+150\text{ °C}$		dV/dt_{on}	0.1	--	1	V/μs
Slew rate off 70 to 40% V_{OUT} , $R_L = 12\text{ Ω}$, $T_j = -40...+150\text{ °C}$		$-dV/dt_{off}$	0.1	--	1	V/μs

Operating Parameters

Operating voltage ⁵⁾ $T_j = -40...+150\text{ °C}$:	$V_{bb(on)}$	5.0	--	24	V
Undervoltage shutdown $T_j = -40...+150\text{ °C}$:	$V_{bb(under)}$	3.5	--	5.0	V
Undervoltage restart $T_j = -40...+150\text{ °C}$:	$V_{bb(u\text{ rst})}$	--	--	5.0	V
Undervoltage restart of charge pump see diagram page 10	$V_{bb(ucp)}$	--	5.6	7.0	V
Undervoltage hysteresis $\Delta V_{bb(under)} = V_{bb(u\text{ rst})} - V_{bb(under)}$	$\Delta V_{bb(under)}$	--	0.2	--	V
Overvoltage shutdown $T_j = -40...+150\text{ °C}$:	$V_{bb(over)}$	24	--	34	V
Overvoltage restart $T_j = -40...+150\text{ °C}$:	$V_{bb(o\text{ rst})}$	23	--	--	V
Overvoltage hysteresis $T_j = -40...+150\text{ °C}$:	$\Delta V_{bb(over)}$	--	0.5	--	V
Overvoltage protection ⁶⁾ $I_{bb} = 40\text{ mA}$ $T_j = -40...+150\text{ °C}$:	$V_{bb(AZ)}$	42	47	--	V
Standby current (pin 4) $V_{IN} = 0$ $T_j = -40...+25\text{ °C}$: $T_j = 150\text{ °C}$:	$I_{bb(off)}$	--	14 17	30 35	μA
Leakage output current (included in $I_{bb(off)}$) $V_{IN} = 0$	$I_{L(off)}$	--	--	12	μA
Operating current (Pin 2) ⁷⁾ , $V_{IN} = 5\text{ V}$ both channels on, $T_j = -40...+150\text{ °C}$	I_{GND}	--	4	6	mA

5) At supply voltage increase up to $V_{bb} = 5.6\text{ V}$ typ without charge pump, $V_{OUT} \approx V_{bb} - 2\text{ V}$

6) See also $V_{ON(CL)}$ in table of protection functions and circuit diagram page 7.

Parameter and Conditions, each channel at $T_j = 25\text{ °C}$, $V_{bb} = 12\text{ V}$ unless otherwise specified	Symbol	Values			Unit
		min	typ	max	
Operating current (Pin 2) ⁷⁾ one channel on, $T_j = -40\dots+150\text{ °C}$:	I_{GND}	--	2	3	mA

Protection Functions

Initial peak short circuit current limit (pin 4 to 1 or 7)	$I_{L(SCp)}$				
$T_j = -40\text{ °C}$:		8	11.5	15	A
$T_j = 25\text{ °C}$:		6	9	12	
$T_j = +150\text{ °C}$:		3.5	6	7.5	
Repetitive short circuit shutdown current limit $T_j = T_{jt}$ (see timing diagrams, page 9)	$I_{L(SCr)}$	--	5	--	A
Thermal overload trip temperature	T_{jt}	150	--	--	°C
Thermal hysteresis	ΔT_{jt}	--	10	--	K
Reverse battery (pin 4 to 2) ⁸⁾	$-V_{bb}$	--	--	32	V
Reverse battery voltage drop ($V_{out} > V_{bb}$) $I_L = -1.8\text{ A}$, each channel	$-V_{ON(rev)}$	--	610	--	mV

Diagnostic Characteristics

Open load detection current (on-condition,)	$I_{L(OL)}$				
$T_j = -40\text{ °C}$:		10	--	200	mA
$T_j = 25\dots150\text{ °C}$:		10	--	150	
Open load detection voltage ⁹⁾ (off-condition)	$V_{OUT(OL)}$				
$T_j = -40\dots150\text{ °C}$:		2	3	4	V
Internal output pull down (pin 1 or 7 to 2), $V_{OUT} = 5\text{ V}$, $T_j = -40\dots150\text{ °C}$	R_O	4	10	30	kΩ

7) Add I_{ST} , if $I_{ST} > 0$, add I_{IN} , if $V_{IN} > 5.5\text{ V}$

8) Requires $150\text{ }\Omega$ resistor in GND connection. The reverse load current through the intrinsic drain-source diode has to be limited by the connected load. Note that the power dissipation is higher compared to normal operating conditions due to the voltage drop across the intrinsic drain-source diode. The temperature protection is not active during reverse current operation! Input and Status currents have to be limited (see max. ratings page 2 and circuit page 7).

9) External pull up resistor required for open load detection in off state.

Parameter and Conditions, each channel at $T_j = 25\text{ °C}$, $V_{bb} = 12\text{ V}$ unless otherwise specified	Symbol	Values			Unit
		min	typ	max	
Input and Status Feedback¹⁰⁾					
Input resistance $T_j = -40..+150\text{ °C}$, see circuit page 6	R_i	2.5	3.5	6	k Ω
Input turn-on threshold voltage $\nearrow T_j = -40..+150\text{ °C}$:	$V_{IN(T+)}$	1.7	--	3.5	V
Input turn-off threshold voltage $\searrow T_j = -40..+150\text{ °C}$:	$V_{IN(T-)}$	1.5	--	--	V
Input threshold hysteresis	$\Delta V_{IN(T)}$	--	0.5	--	V
Off state input current (pin 3 or 6), $V_{IN} = 0.4\text{ V}$, $T_j = -40..+150\text{ °C}$	$I_{IN(off)}$	1	--	50	μA
On state input current (pin 3 or 6), $V_{IN} = 3.5\text{ V}$, $T_j = -40..+150\text{ °C}$	$I_{IN(on)}$	20	50	90	μA
Delay time for status with open load after switch off (other channel in off state) (see timing diagrams, page 10), $T_j = -40..+150\text{ °C}$	$t_{d(ST\ OL4)}$	100	320	800	μs
Delay time for status with open load after switch off (other channel in on state) (see timing diagrams, page 10), $T_j = -40..+150\text{ °C}$	$t_{d(ST\ OL5)}$	--	5	20	μs
Status invalid after positive input slope (open load) $T_j = -40 \dots +150\text{ °C}$:	$t_{d(ST)}$	--	200	600	μs
Status output (open drain)					
Zener limit voltage $T_j = -40\dots+150\text{ °C}$, $I_{ST} = +1.6\text{ mA}$:	$V_{ST(high)}$	5.4	6.1	--	V
ST low voltage $T_j = -40\dots+25\text{ °C}$, $I_{ST} = +1.6\text{ mA}$:	$V_{ST(low)}$	--	--	0.4	
$T_j = +150\text{ °C}$, $I_{ST} = +1.6\text{ mA}$:		--	--	0.6	

¹⁰⁾ If a ground resistor R_{GND} is used, add the voltage drop across this resistor.

Truth Table

		IN1	IN2	OUT1	OUT2	ST BTS610L1 BTS611L1	ST BTS612N1
Normal operation		L	L	L	L	H	H
		L	H	L	H	H	H
		H	L	H	L	H	H
		H	H	H	H	H	H
Open load	Channel 1	L	L	Z	L	H(L ¹¹)	L
		L	H	Z	H	H	H
		H	X	H	X	L	H
	Channel 2	L	L	L	Z	H(L ¹¹)	L
		H	L	H	Z	H	H
		X	H	X	H	L	H
Short circuit to V_{bb}	Channel 1	L	L	H	L	L ¹²	L
		L	H	H	H	H	H
		H	X	H	X	H(L ¹³)	H
	Channel 2	L	L	L	H	L ¹²	L
		H	L	H	H	H	H
		X	H	X	H	H(L ¹³)	H
Overtemperature	both channel	L	L	L	L	H	H
		X	H	L	L	L	L
		H	X	L	L	L	L
	Channel 1	L	X	L	X	H	H
		H	X	L	X	L	L
	Channel 2	X	L	X	L	H	H
X		H	X	L	L	L	
Undervoltage/ Overvoltage		X	X	L	L	H	H

L = "Low" Level X = don't care Z = high impedance, potential depends on external circuit
 H = "High" Level Status signal after the time delay shown in the diagrams (see fig 5. page 10)

Terms

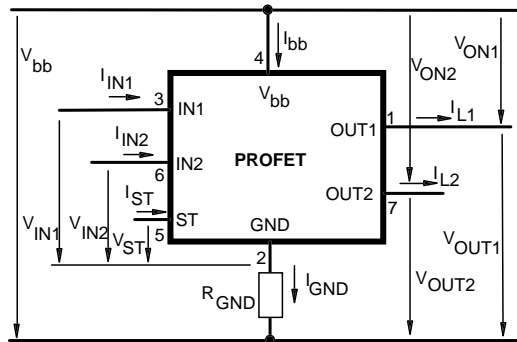

Input circuit (ESD protection)

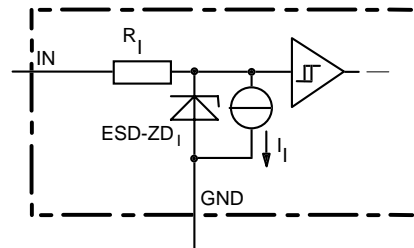

ESD zener diodes are not to be used as voltage clamp at DC conditions. Operation in this mode may result in a drift of the zener voltage (increase of up to 1 V).

- 11) With additional external pull up resistor
- 12) An external short of output to V_{bb} , in the off state, causes an internal current from output to ground. If R_{GND} is used, an offset voltage at the GND and ST pins will occur and the $V_{ST\ low}$ signal may be erroneous.
- 13) Low resistance to V_{bb} may be detected in the ON-state by the no-load-detection

Status output

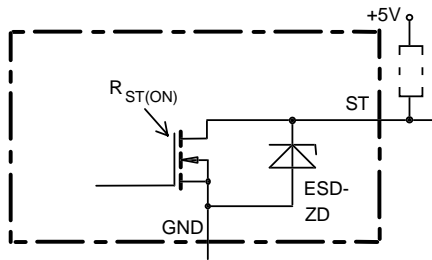

ESD-Zener diode: 6.1 V typ., max 5 mA;
 $R_{ST(ON)} < 380 \Omega$ at 1.6 mA, ESD zener diodes are not to be used as voltage clamp at DC conditions.
 Operation in this mode may result in a drift of the zener voltage (increase of up to 1 V).

overvoltage output clamp

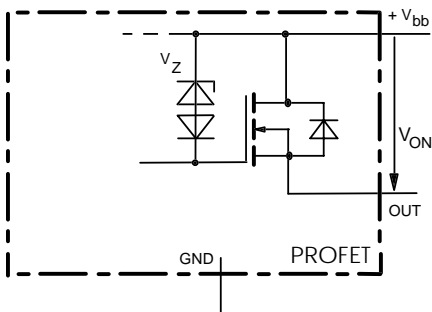

V_{ON} clamped to 47 V typ.

Overvolt. and reverse batt. protection

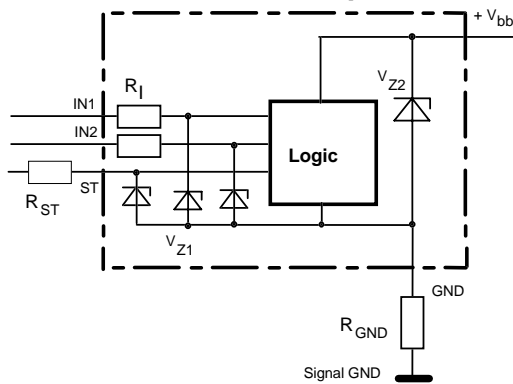

$V_{Z1} = 6.1 \text{ V typ.}$, $V_{Z2} = 47 \text{ V typ.}$, $R_I = 3.5 \text{ k}\Omega \text{ typ.}$,
 $R_{GND} = 150 \Omega$

Open-load detection

ON-state diagnostic condition: $V_{ON} < R_{ON} \cdot I_{L(OL)}$; IN high

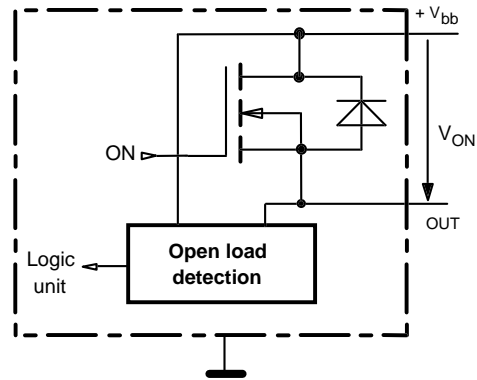

OFF-state diagnostic condition: $V_{OUT} > 3 \text{ V typ.}$; IN low

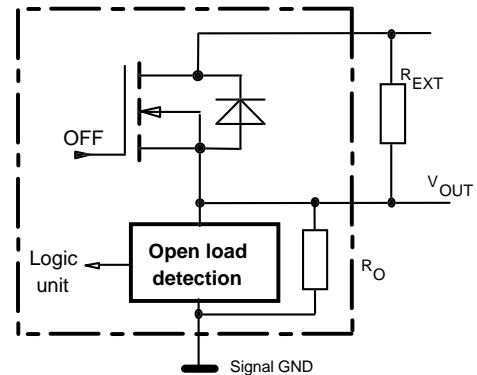

GND disconnect

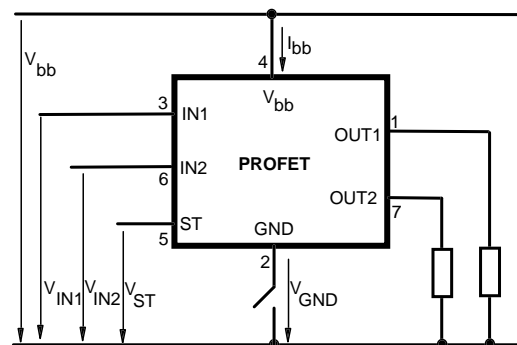

In case of Input=high is $V_{OUT} \approx V_{IN} - V_{IN(T+)}$.
 Due to $V_{GND} > 0$, no $V_{ST} = \text{low}$ signal available.

GND disconnect with GND pull up

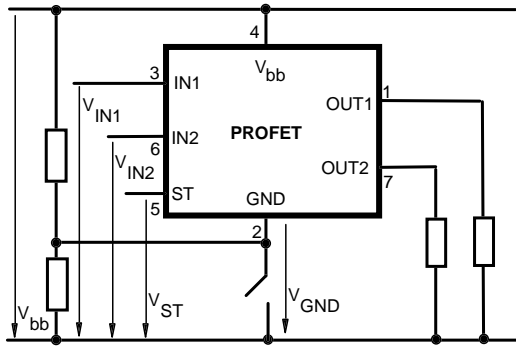

If $V_{GND} > V_{IN} - V_{IN(T+)}$ device stays off
 Due to $V_{GND} > 0$, no V_{ST} = low signal available.

Typ. transient thermal impedance chip case

$Z_{thJC} = f(t_p, D)$, $D = t_p/T$, one Channel active

Z_{thJC} [K/W]

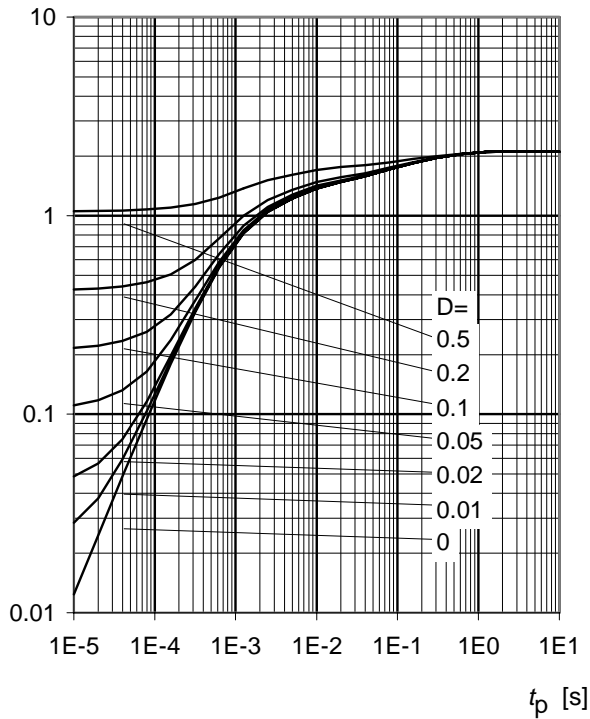

Typ. transient thermal impedance chip case

$Z_{thJC} = f(t_p, D)$, $D = t_p/T$, both Channel parallel

Z_{thJC} [K/W]

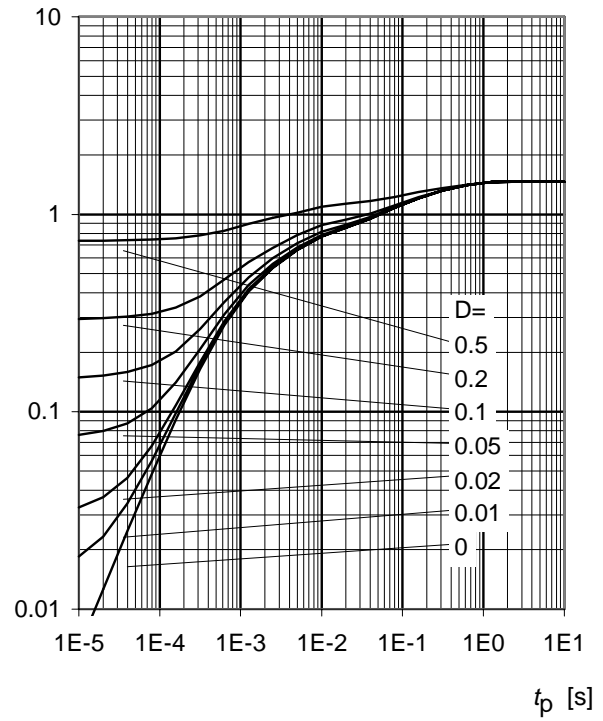

Timing diagrams

Both channels are symmetric and consequently the diagrams are valid for each channel as well as for permuted channels

Figure 1a: V_{bb} turn on:

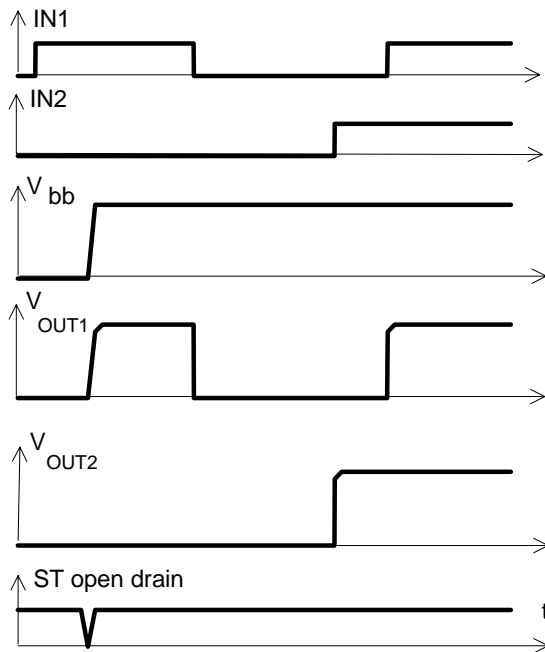

Figure 2a: Switching a lamp:

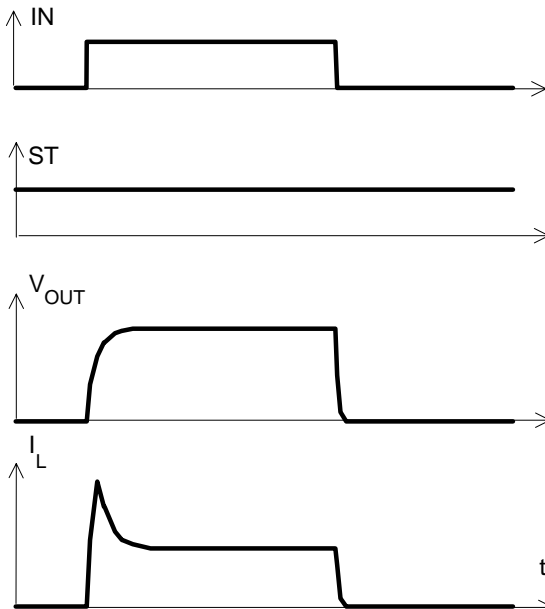
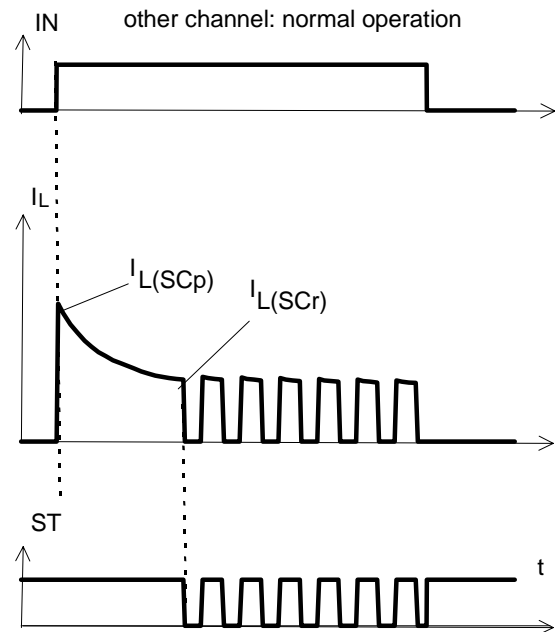

Figure 3a: Short circuit shut down by overtemperature, reset by cooling



Heating up may require several milliseconds, depending on external conditions

Figure 4a: Overtemperature: Reset if $T_j < T_{jt}$

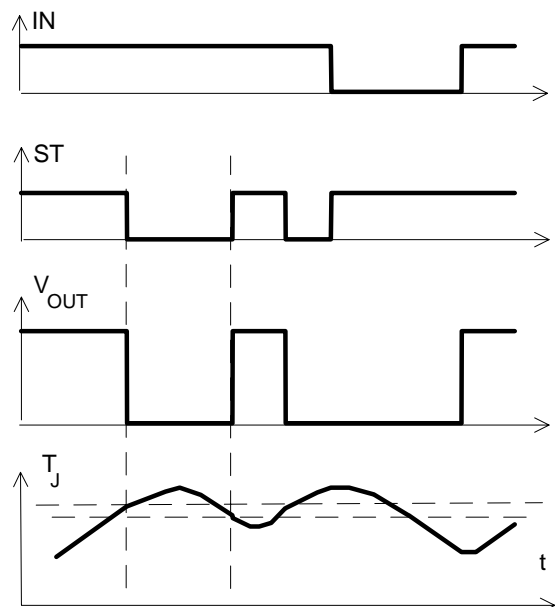

Figure 5a: Open load: detection in ON-state, open load occurs in on-state

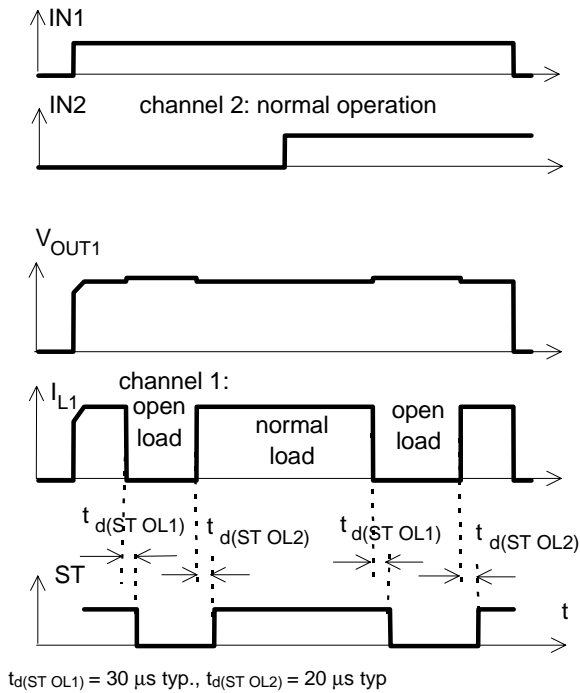

Figure 5b: Open load: detection in ON-state, turn on/off to open load

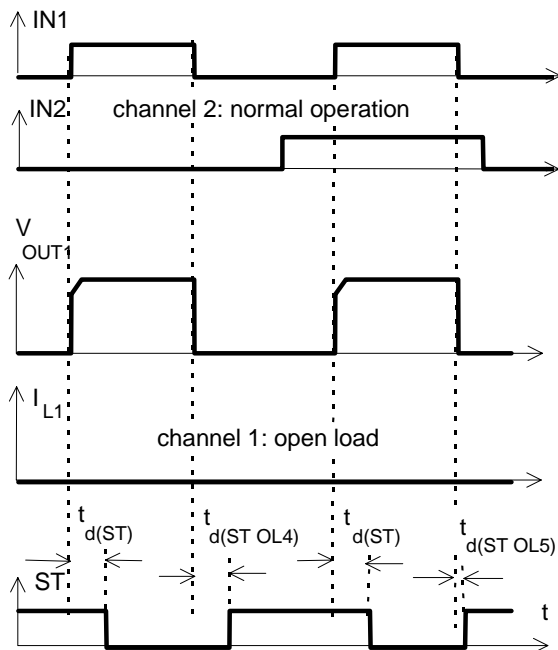

Figure 5c: Open load: detection in ON- and OFF-state (with REXT), turn on/off to open load

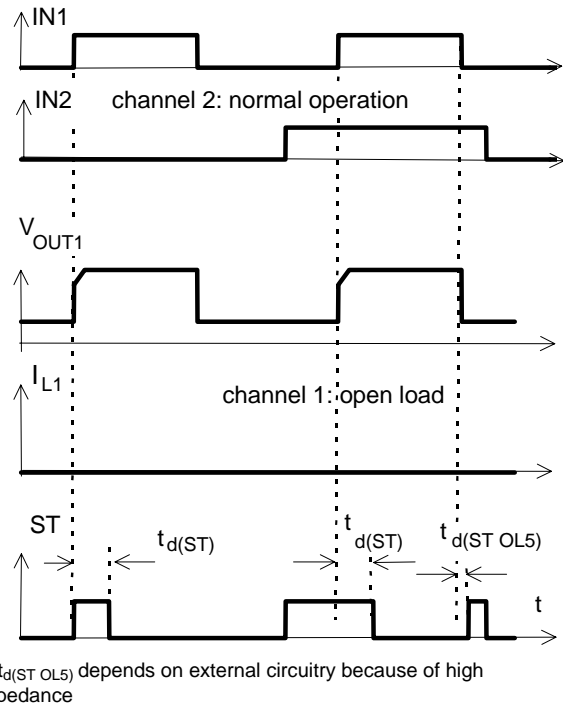

Figure 6a: Undervoltage:

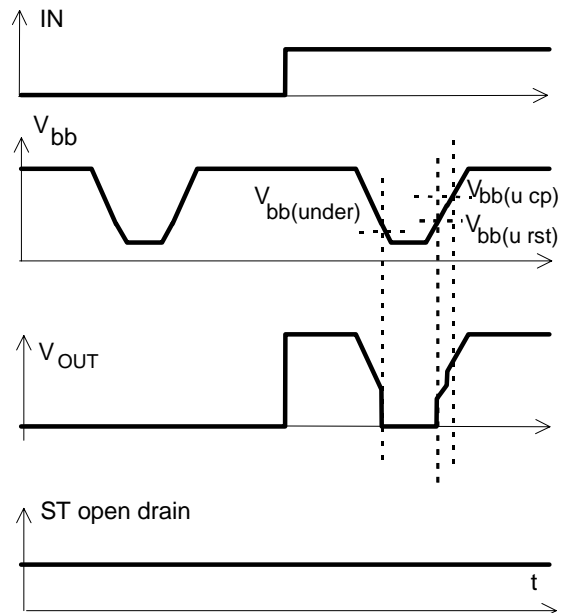

Figure 6b: Undervoltage restart of charge pump

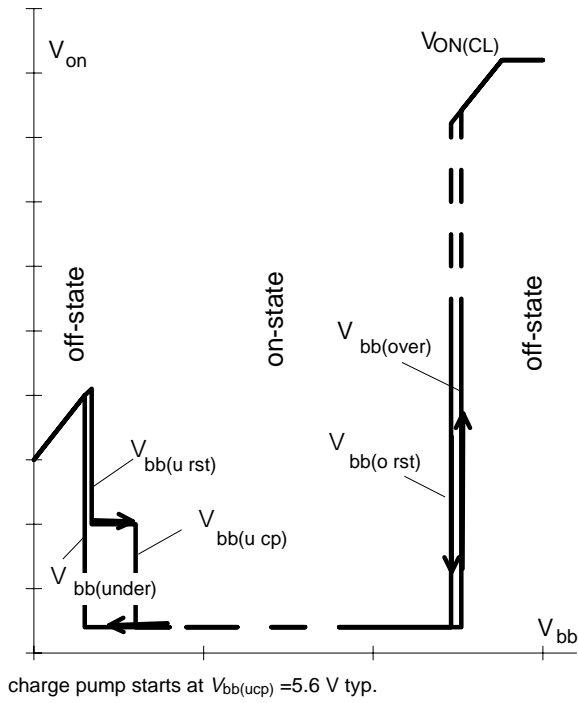
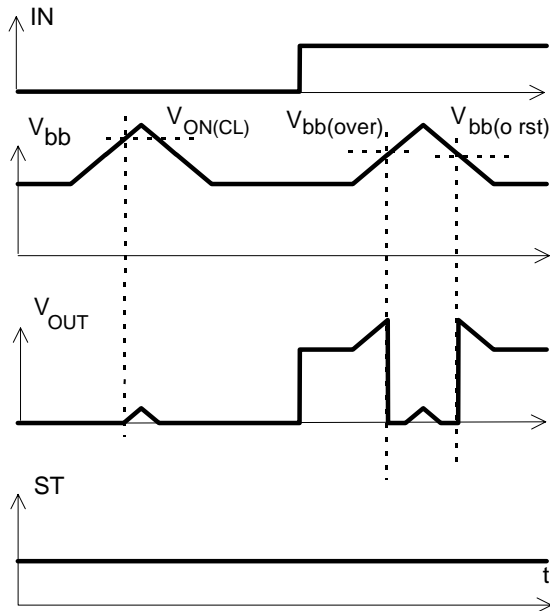

Figure 7a: Overvoltage:



Package and Ordering Code

All dimensions in mm

Standard TO-220AB/7

Ordering code

BTS610L1	Q67060-S6300-A2
----------	-----------------

