

SGM3001 SGM3002

Low ON-Resistance, Low Voltage, SPDT Analog Switch

GENERAL DESCRIPTION

The SGM3001(single) and SGM3002(dual) are bidirectional, low ON-resistance, low voltage, single-pole/double-throw (SPDT) CMOS analog switches designed to operate from a single +1.8V to +5.5V supply. Targeted applications include battery powered equipment that benefit from low R_{ON} (2.5Ω) and fast switching speeds SGM3001 ($t_{ON} = 11\text{ ns}$, $t_{OFF} = 30\text{ ns}$) and SGM3002 ($t_{ON} = 11\text{ ns}$, $t_{OFF} = 8\text{ ns}$).

The on resistance profile is very flat over the full analog signal range. This ensures excellent linearity and low distortion when switching audio signals.

The SGM3002 is a committed dual single-pole/double-throw (SPDT) that consist of two normally open (NO) and two normally close (NC) switches. This configuration can be used as a dual 2-to-1 multiplexer.

The single version SGM3001 is available in a SC70-6 package. The dual version SGM3002 is available in a MSOP-10 package.

APPLICATIONS

- Battery powered, Handheld, and Portable Equipments
 - Cellular/mobile Phones
 - Laptops, Notebooks, Palmtops
- Communication Systems
- Sample-and-Hold Circuits
- Audio Signal Routing
- Audio and Video Switching
- Portable Test and Measurement
- Medical Equipment

FEATURES

- Low Voltage Operation : 1.8 V to 5.5 V
- Low On-Resistance: 2.5Ω (TYP)
- Low On-Resistance Flatness
- -3 dB Bandwidth: 120 MHz
- Fast Switching Time
 - t_{ON} 11 ns
 - t_{OFF} 30 ns (SGM3001)
 - t_{OFF} 8 ns(SGM3002)
- Rail-to-Rail Operation
- Typical Power Consumption (<0.01 μ W)
- TTL/CMOS Compatible
- Microsize Package

PIN CONFIGURATIONS (TOP VIEW)

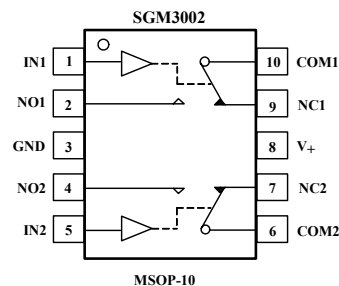
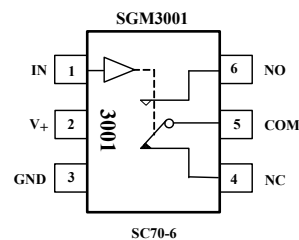

FUNCTION TABLE

LOGIC	NO, NO1, NO2	NC, NC1, NC2
0	OFF	ON
1	ON	OFF



ORDERING INFORMATION

MODEL	PIN-PACKAGE	SPECIFIED TEMPERATURE RANGE	ORDERING NUMBER	PACKAGE MARKING	PACKAGE OPTION
SGM3001	SC70-6	- 40°C to +125°C	SGM3001XC6/TR	3001	Tape and Reel, 3000
SGM3002	MSOP-10	- 40°C to +125°C	SGM3002XMS/TR	SGM3002XMS	Tape and Reel, 3000

www.DataSheet4U.com

ABSOLUTE MAXIMUM RATINGS

V₊ to GND.....- 0.3V to +6V
 Analog, Digital voltage range(1)..... - 0.3V to V₊ + 0.3V
 Continuous Current NO, NC, or COM..... ±300mA
 Peak Current NO, NC, or COM ±500mA
 Package Thermal Resistance @ T_A = 25°C
 SC70-6, θ_{JA}.....333°C/W
 MSOP-10, θ_{JA}.....205°C/W

Operating Temperature Range.....- 40°C to +125°C
 Junction Temperature.....+150°C
 Storage Temperature.....- 65°C to +150°C
 Lead Temperature (soldering, 10s).....260°C
 ESD Susceptibility
 HBM.....2000V
 MM.....400V

Stresses beyond those listed under “Absolute Maximum Ratings” may cause permanent damage to the device. These are stress ratings only, and functional operation of the device at these or any other conditions beyond those indicated in the operational sections of the specifications is not implied. Exposure to absolute maximum rating conditions for extended periods may affect device reliability.

(1) Signals on NC, NO, or COM or IN exceeding V₊ will be clamped by internal diodes. Limit forward diode current to maximum current ratings.

PIN DESCRIPTION

NAME	SC70-6 PIN	MSOP-10 PIN	FUNCTION
V ₊	2	8	Power supply
GND	3	3	Ground
IN(IN1, IN2)	1	1,5	Digital control pin to connect the COM terminal to the NO or NC terminals
COM(COM1, COM2)	5	6,10	Common terminal
NO(NO1, NO2)	6	2,4	Normally-open terminal
NC(NC1, NC2)	4	7,9	Normally-closed terminal

Note: NO, NC and COM terminal may be an input or output.

ELECTRICAL CHARACTERISTICS

(V₊ = +5 V ± 10%, GND = 0 V, All Specifications - 40°C to +125°C, unless otherwise noted. Typical values are at T_A = + 25°C.)

PARAMETER	SYMBOL	CONDITIONS	SGM3001/3002			
			+25°C	- 40°C to +125°C	UNITS	MIN/ MAX
ANALOG SWITCH						
Analog Signal Range	V _{NO} , V _{NC} , V _{COM}			0	V	MIN
				V ₊	V	MAX
On-Resistance	R _{ON}	0 ≤ V _{NO} or V _{NC} ≤ V ₊ , I _{COM} = -10 mA, Test Circuit 1	2.5		Ω	TYP
			3.7	4.5	Ω	MAX
On-Resistance Match Between Channels	ΔR _{ON}	0 ≤ V _{NO} or V _{NC} ≤ V ₊ , I _{COM} = -10 mA, Test Circuit 1	0.1		Ω	TYP
			0.8	0.9	Ω	MAX
On-Resistance Flatness	R _{FLAT(ON)}	0 ≤ V _{NO} or V _{NC} ≤ V ₊ , I _{COM} = -10 mA, Test Circuit 1	0.75		Ω	TYP
			0.85	0.9	Ω	MAX
LEAKAGE CURRENTS						
Source OFF Leakage current	I _{NC(OFF)} , I _{NO(OFF)}	V _{NO} or V _{NC} = 4.5V/1V, V _{COM} = 1V/4.5V, V ₊ = +5.5V, Test Circuit 2	±5		nA	TYP
			±11	±1000	nA	MAX
Channel ON Leakage current	I _{NC(ON)} , I _{NO(ON)} , I _{COM(ON)}	V _{NO} or V _{NC} = V _{COM} = 1V or 4.5V, V ₊ = +5.5V, Test Circuit 3	±5		nA	TYP
			±11	±1000	nA	MAX
DIGITAL INPUTS						
Input High Voltage	V _{INH}			2.4	V	MIN
Input Low Voltage	V _{INL}			0.8	V	MAX
Input Current	I _{INL} or I _{INH}	V _{IN} = V _{INH} or V _{INL}	±0.01		μA	TYP
			±0.1	±1	μA	MAX
DYNAMIC CHARACTERISTICS						
Turn-On Time	t _{ON}	V _{NO} or V _{NC} = 3V, R _L = 300Ω, C _L = 35pF, Test Circuit 4	11		ns	TYP
Turn-Off Time	SGM3001	V _{NO} or V _{NC} = 3V, R _L = 300Ω, C _L = 35pF, Test Circuit 4	30		ns	TYP
	SGM3002		8		ns	TYP
Charge Injection,	Q	C _L = 1.0nF, V _G = 0V, R _G = 0, Test Circuit 5	3		pC	TYP
Break-Before-Make Time Delay	t _d	V _{NO1} or V _{NC1} = V _{NO2} or V _{NC2} = 3V, R _L = 300Ω, C _L = 35pF, Test Circuit 6	10		ns	TYP
Off Isolation	O _{ISO}	R _L = 50Ω, C _L = 5pF, Test Circuit 7	f = 10MHz	-45	dB	TYP
			f = 1MHz	-65	dB	TYP
Channel-to-Channel Crosstalk (SGM3002 Only)	X _{TALK}	R _L = 50Ω, C _L = 5pF, Test Circuit 8	f = 10MHz	-35	dB	TYP
			f = 1MHz	-55	dB	TYP
Total Harmonic Distortion	THD	f = 20Hz to 20KHz, V _{COM} = 3.5V _{P-P} , R _L = 600Ω, C _L = 50pF	0.006		%	TYP
Bandwidth -3 dB	BW	R _L = 50Ω, C _L = 5pF, Test Circuit 9	120		MHz	TYP
Source OFF Capacitance	C _{NC(OFF)} , C _{NO(OFF)}		14		pF	TYP
Channel ON Capacitance	C _{NC(ON)} , C _{NO(ON)} , C _{COM(ON)}		53		pF	TYP
POWER REQUIREMENTS						
Power Supply Current	I ₊	V ₊ = +5.5V, V _{IN} = 0V or 5V	0.001		μA	TYP
				1	μA	MAX

Specifications subject to change without notice.

ELECTRICAL CHARACTERISTICS

(V₊ = +3 V ± 10%, GND = 0 V, All Specifications - 40°C to +125°C, unless otherwise noted. Typical values are at T_A = + 25°C.)

PARAMETER	SYMBOL	CONDITIONS	SGM3001/3002			
			+25°C	- 40°C to +125°C	UNITS	MIN/ MAX
ANALOG SWITCH						
Analog Signal Range	V _{NO} , V _{NC} , V _{COM}			0	V	MIN
				V ₊	V	MAX
On-Resistance	R _{ON}	0 ≤ V _{NO} or V _{NC} ≤ V ₊ , I _{COM} = -10 mA, Test Circuit 1	2.9	3	Ω	TYP
			4.4	6	Ω	MAX
On-Resistance Match Between Channels	ΔR _{ON}	0 ≤ V _{NO} or V _{NC} ≤ V ₊ , I _{COM} = -10 mA, Test Circuit 1	0.1		Ω	TYP
			0.8	0.9	Ω	MAX
On-Resistance Flatness	R _{FLAT(ON)}	0 ≤ V _{NO} or V _{NC} ≤ V ₊ , I _{COM} = -10 mA, Test Circuit 1	0.9		Ω	TYP
			1	1.2	Ω	MAX
LEAKAGE CURRENTS						
Source OFF Leakage current	I _{NC(OFF)} , I _{NO(OFF)}	V _{NO} or V _{NC} = 3V/1V, V _{COM} = 1V/3V, V ₊ = +3.3V, Test Circuit 2	±7		nA	TYP
			±13	±1000	nA	MAX
Channel ON Leakage current	I _{NC(ON)} , I _{NO(ON)} , I _{COM(ON)}	V _{NO} or V _{NC} = V _{COM} = 1V or 3V, V ₊ = +3.3V, Test Circuit 3	±7		nA	TYP
			±13	1000	nA	MAX
DIGITAL INPUTS						
Input High Voltage	V _{INH}			2.0	V	MIN
Input Low Voltage	V _{INL}			0.4	V	MAX
Input Current	I _{INL} or I _{INH}	V _{IN} = V _{INH} or V _{INL}	±0.01		μA	TYP
			±0.1	±1	μA	MAX
DYNAMIC CHARACTERISTICS						
Turn-On Time	t _{ON}	V _{NO} or V _{NC} = 2V, R _L = 300Ω, C _L = 35pF, Test Circuit 4	12		ns	TYP
Turn-Off Time	SGM3001	V _{NO} or V _{NC} = 2V, R _L = 300Ω, C _L = 35pF, Test Circuit 4	31		ns	TYP
	SGM3002		9		ns	TYP
Charge Injection	Q	C _L = 1.0nF, V _G = 0V, R _G = 0, Test Circuit 5	3		pC	TYP
Break-Before-Make Time Delay	t _d	V _{NO1} or V _{NC1} = V _{NO2} or V _{NC2} = 2V, R _L = 300Ω, C _L = 35pF, Test Circuit 6	11		ns	TYP
Off Isolation	O _{ISO}	R _L = 50Ω, C _L = 5pF, Test Circuit 7	f = 10MHz	-45	dB	TYP
			f = 1MHz	-65	dB	TYP
Channel-to-Channel Crosstalk (SGM3002 Only)	X _{TALK}	R _L = 50Ω, C _L = 5pF, Test Circuit 8	f = 10MHz	-35	dB	TYP
			f = 1MHz	-55	dB	TYP
Total Harmonic Distortion	THD	f = 20Hz to 20KHz, V _{COM} = 2V _{P-P} , R _L = 600Ω, C _L = 50pF	0.005		%	TYP
Bandwidth -3 dB	BW	R _L = 50Ω, C _L = 5pF, Test Circuit 9	120		MHz	TYP
Source OFF Capacitance	C _{NC(OFF)} , C _{NO(OFF)}		14		pF	TYP
Channel ON Capacitance	C _{NC(ON)} , C _{NO(ON)} , C _{COM(ON)}		53		pF	TYP
POWER REQUIREMENTS						
Power Supply Current	I ₊	V ₊ = +3.3V, V _{IN} = 0V or 3V	0.001		μA	TYP
				1	μA	MAX

Specifications subject to change without notice.

TYPICAL PERFORMANCE CHARACTERISTICS

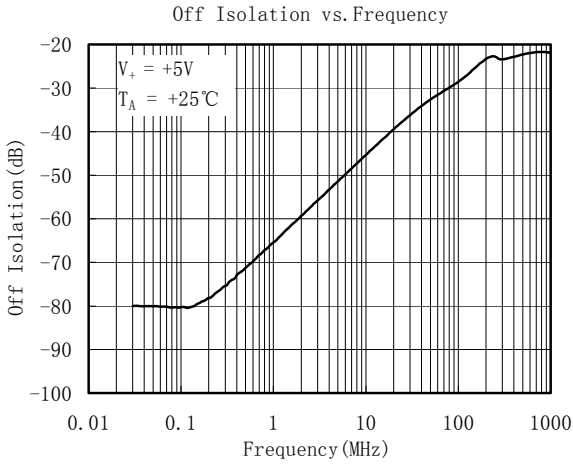
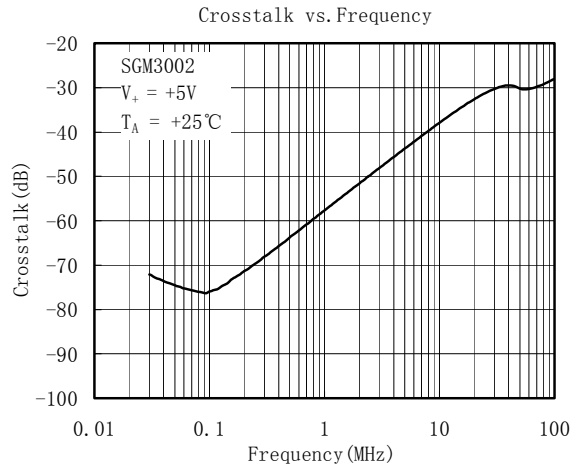
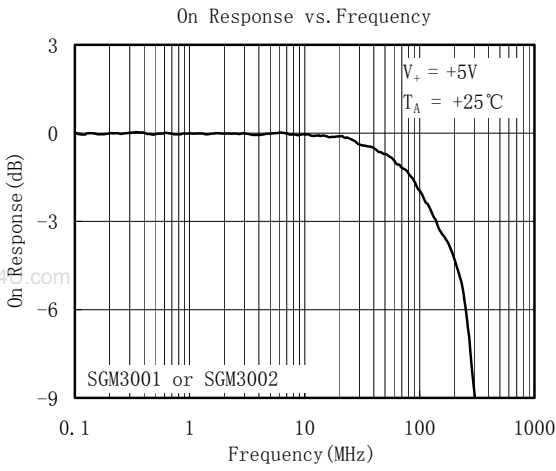

TEST CIRCUITS

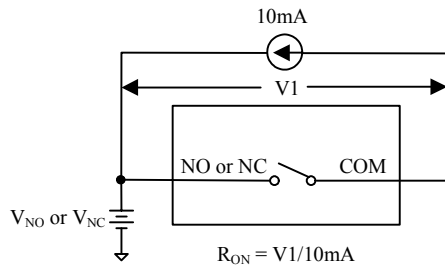

Test Circuit 1. On Resistance

www.DataSheet4U.com

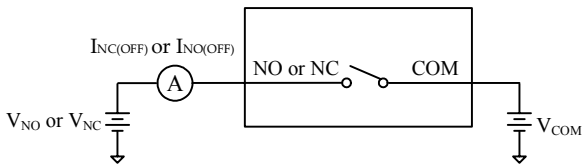

Test Circuit 2: Off Leakage

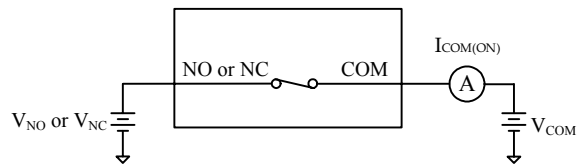

Test Circuit 3: On Leakage

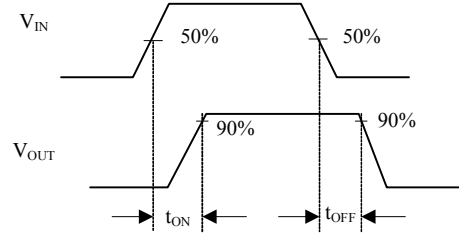
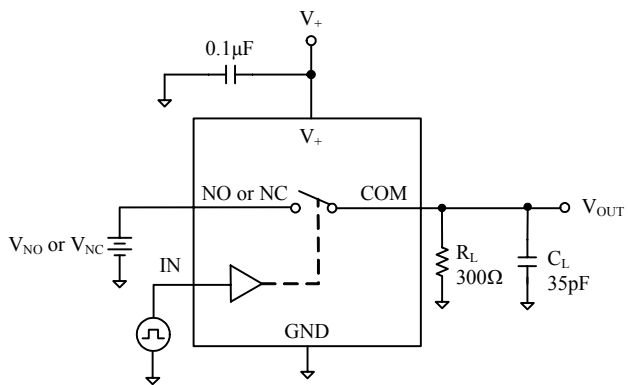

Test Circuit 4: Switching Times

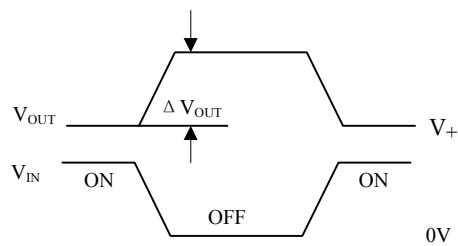
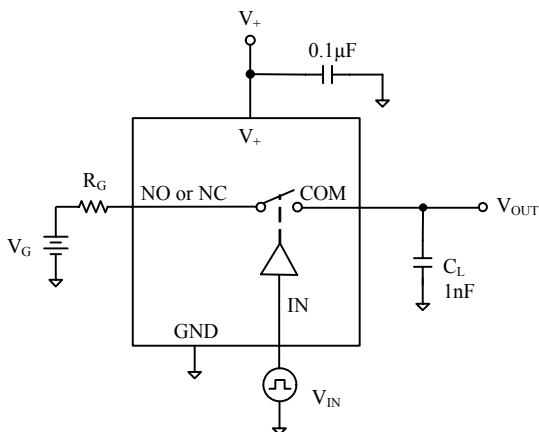

Test Circuit 5: Charge Injection

TEST CIRCUITS(Cont.)

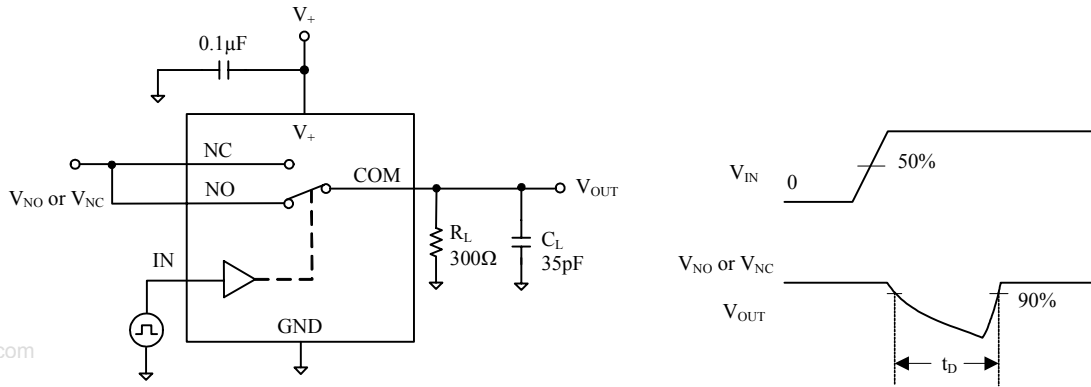

Test Circuit 6. Break-Before-Make Time Delay, t_d

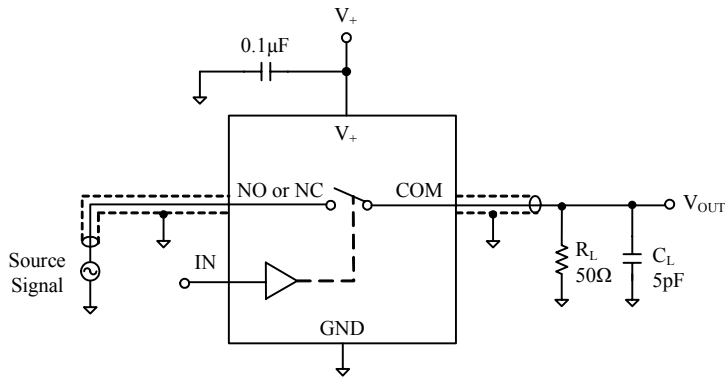

Test Circuit 7. Off Isolation

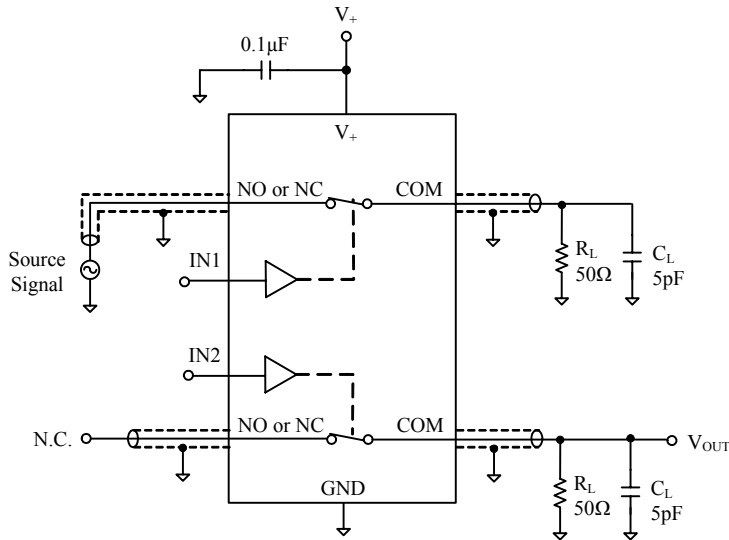

$$\text{Channel To Channel Crosstalk} = -20 \times \log \frac{V_{NO \text{ or } V_{NC}}}{V_{OUT}}$$

Test Circuit 8. Channel-to-Channel Crosstalk

TEST CIRCUITS (Cont.)

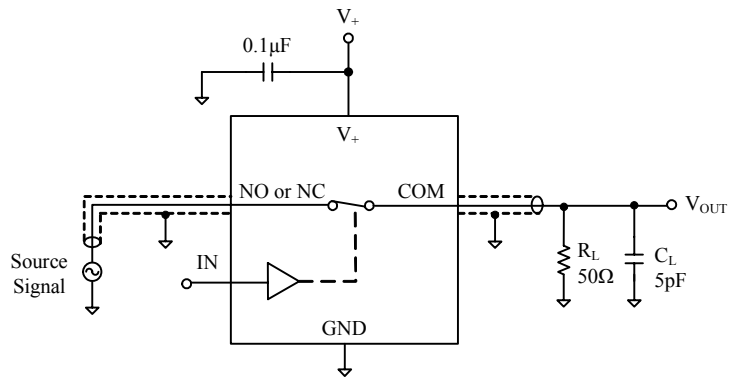

Test Circuit 9. Bandwidth

PACKAGE OUTLINE DIMENSIONS

SC70-6

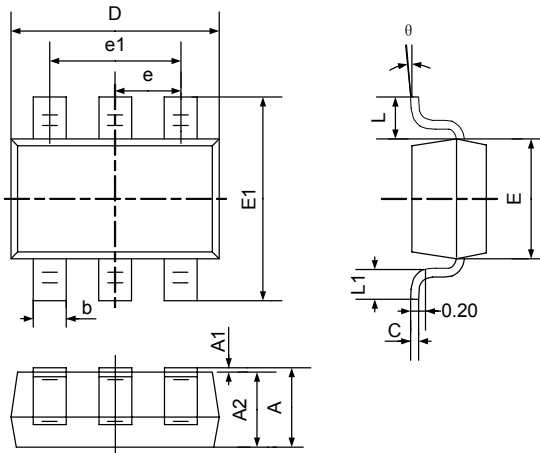

Symbol	Dimensions In Millimeters		Dimensions In Inches	
	Min	Max	Min	Max
A	0.900	1.100	0.035	0.043
A1	0.000	0.100	0.000	0.004
A2	0.900	1.000	0.035	0.039
b	0.150	0.350	0.006	0.014
c	0.080	0.150	0.003	0.006
D	2.000	2.200	0.079	0.087
E	1.150	1.350	0.045	0.053
E1	2.150	2.450	0.085	0.096
e	0.650TYP		0.026TYP	
e1	1.200	1.400	0.047	0.055
L	0.525REF		0.021REF	
L1	0.260	0.460	0.010	0.018
θ	0°	8°	0°	8°

PACKAGE OUTLINE DIMENSIONS

MSOP-10

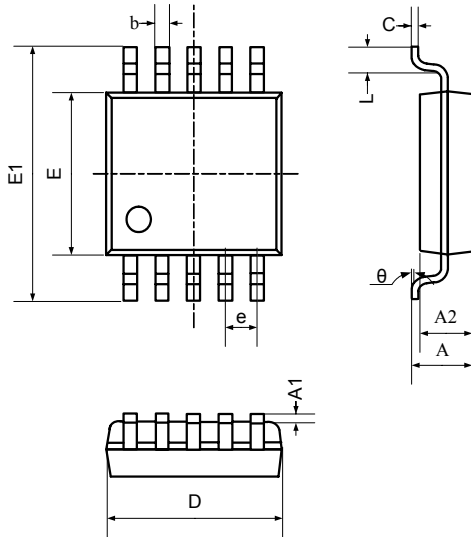

Symbol	Dimensions In Millimeters		Dimensions In Inches	
	Min	Max	Min	Max
A	0.800	1.200	0.031	0.047
A1	0.000	0.200	0.000	0.008
A2	0.760	0.970	0.030	0.038
b	0.30 TYP		0.012 TYP	
c	0.152 TYP		0.006 TYP	
D	2.900	3.100	0.114	0.122
e	0.50 TYP		0.020 TYP	
E	2.900	3.100	0.114	0.122
E1	4.700	5.100	0.185	0.201
L	0.410	0.650	0.016	0.026
θ	0°	6°	0°	6°

REVISION HISTORY

Location	Page
11/06— Data Sheet changed from REV.A to REV.B	
Changes to ABSOLUTE MAXIMUM RATINGS	2
10/07— Data Sheet changed from REV.B to REV.C	
Deletes to TYPICAL PERFORMANCE CHARACTERISTICS	5

www.DataSheet4U.com

Shengbang Microelectronics Co, Ltd

Unit 3, ChuangYe Plaza
No.5, TaiHu Northern Street, YingBin Road Centralized Industrial Park
Harbin Development Zone
Harbin, HeiLongJiang 150078
P.R. China
Tel.: 86-451-84348461
Fax: 86-451-84308461
www.sg-micro.com