

**INTELLIGENT POWER LOW SIDE SWITCH**

**Features**

- Over temperature shutdown
- Over current shutdown
- Active clamp
- Low current & logic level input
- ESD protection
- Optimized Turn On/Off for EMI
- Diagnostic on the input current

**Description**

The IPS1011(S)(R) is a three terminal Intelligent Power Switch (IPS) that features a low side MOSFET with over-current, over-temperature, ESD protection and drain to source active clamp. This device offers protections and the high reliability required in harsh environments. The switch provides efficient protection by turning OFF the power MOSFET when the temperature exceeds 165°C or when the drain current reaches 85A. The device restarts once the input is cycled. A serial resistance connected to the input provides the diagnostic. The avalanche capability is significantly enhanced by the active clamp and covers most inductive load demagnetizations.

**Product Summary**

Rds(on)	13mΩ (max.)
Vclamp	36V
Ishutdown	85A (typ.)

**Packages**

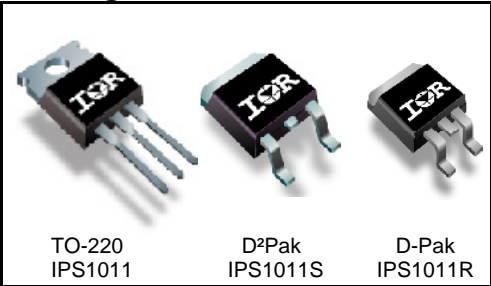

**Typical Connection**

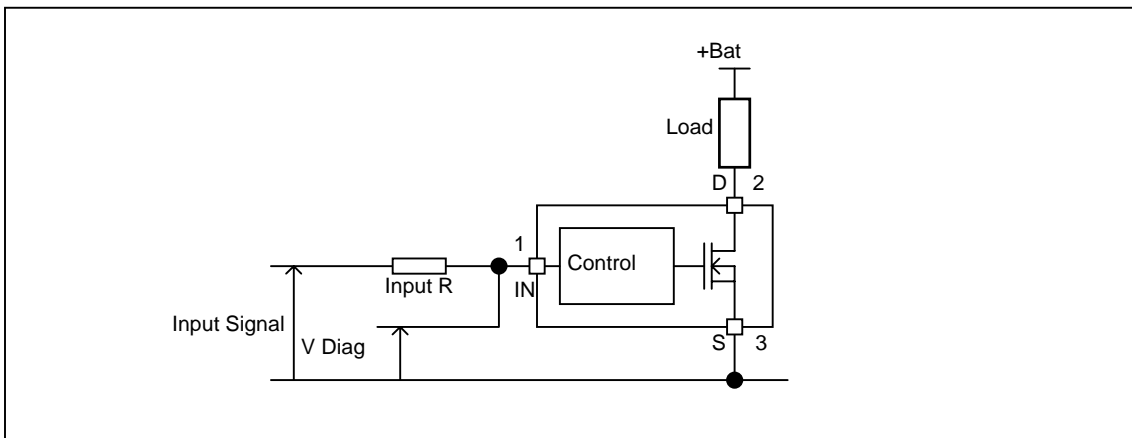

## Absolute Maximum Ratings

Absolute maximum ratings indicate sustained limits beyond which damage to the device may occur. All voltage parameters are referenced to Ground lead. (Tambient=25°C unless otherwise specified).

Symbol	Parameter	Min.	Max.	Units
Vds	Maximum drain to source voltage	-0.3	36	V
Vds cont.	Maximum continuous drain to source voltage	-	28	V
Vin	Maximum input voltage	-0.3	6	V
Isd cont.	Max diode continuous current (limited by thermal dissipation)	—	5	A
Pd	Maximum power dissipation (internally limited by thermal protection)			
	Rth=5°C/W IPS1011	—	25	W
	Rth=40°C/W IPS1011S 1" sqr. footprint	—	3.1	
Rth=50°C/W IPS1011R 1" sqr. footprint	—	2.5		
ESD	Electrostatic discharge voltage (Human body) C=100pF, R=1500Ω			kV
	Between drain and source	—	4	
	Other combinations	—	3	
	Electrostatic discharge voltage (Machine Model) C=200pF, R=0Ω			
	Between drain and source	—	0.5	
	Other combinations	—	0.3	
Tj max.	Max. storage & operating temperature junction temperature	-40	150	°C
Tsoldering	Lead soldering temperature (10 seconds)	—	300	°C

## Thermal Characteristics

Symbol	Parameter	Typ.	Max.	Units
Rth1	Thermal resistance junction to ambient IPS1011 TO-220 free air	50	—	°C/W
Rth2	Thermal resistance junction to case IPS1011 TO-220	1.2	—	
Rth1	Thermal resistance junction to ambient IPS1011S D <sup>2</sup> Pak std. footprint	60	—	
Rth2	Thermal resistance junction to ambient IPS1011S D <sup>2</sup> Pak 1" sqr. footprint	40	—	
Rth3	Thermal resistance junction to case IPS1011S D <sup>2</sup> Pak	1.2	—	
Rth1	Thermal resistance junction to ambient IPS1011R D-Pak std. footprint	70	—	
Rth2	Thermal resistance junction to ambient IPS1011R D-Pak 1" sqr. footprint	50	—	
Rth3	Thermal resistance junction to case IPS1011R D-Pak	1.2	—	

## Recommended Operating Conditions

These values are given for a quick design. For operation outside these conditions, please consult the application notes.

Symbol	Parameter	Min.	Max.	Units
VIH	High level input voltage	4.5	5.5	
VIL	Low level input voltage	0	0.5	
Ids	Continuous drain current, Tambient=85°C, Tj=125°C, Vin=5V			A
	Rth=5°C/W IPS1011	—	18	
	Rth=40°C/W IPS1011S 1" sqr. Footprint	—	6.5	
	Rth=50°C/W IPS1011R 1" sqr. Footprint	—	6	
Rin	Recommended resistor in series with IN pin to generate a diagnostic	0.5	10	kΩ
Max L	Max recommended load inductance (including line inductance) (1)	—	5	μH
Max F	Max frequency (switching losses = conduction losses)	—	200	Hz
Max t rise	Max Input rising time	—	1	μs

(1) Higher inductance is possible if maximum load current is limited - see figure 11

## Static Electrical Characteristics

T<sub>j</sub>=25°C, V<sub>cc</sub>=14V (unless otherwise specified)

Symbol	Parameter	Min.	Typ.	Max.	Units	Test Conditions
R <sub>ds(on)</sub>	ON state resistance T <sub>j</sub> =25°C	—	10	13	mΩ	V <sub>in</sub> =5V, I <sub>ds</sub> =30A
	ON state resistance T <sub>j</sub> =150°C (2)	—	19	25		
I <sub>dss1</sub>	Drain to source leakage current	—	0.1	10	μA	V <sub>cc</sub> =14V, T <sub>j</sub> =25°C
I <sub>dss2</sub>	Drain to source leakage current	—	0.2	20		V <sub>cc</sub> =28V, T <sub>j</sub> =25°C
V <sub>clamp1</sub>	Drain to source clamp voltage 1	36	39	—	V	I <sub>d</sub> =20mA
V <sub>clamp2</sub>	Drain to source clamp voltage 2	—	40	42		I <sub>d</sub> =5A
V <sub>in clamp</sub>	IN to source pin clamp voltage	5.5	6.5	7.5		I <sub>in</sub> =1mA
V <sub>th</sub>	Input threshold voltage	—	1.7	—		I <sub>d</sub> =10mA

## Switching Electrical Characteristics

V<sub>cc</sub>=14V, Resistive load=0.5Ω, R<sub>input</sub>=50Ω, V<sub>in</sub>=5V, T<sub>j</sub>=25°C

Symbol	Parameter	Min.	Typ.	Max.	Units	Test Conditions
T <sub>don</sub>	Turn-on delay time to 20%	15	50	150	μs	See figure 2
T <sub>r</sub>	Rise time 20% to 80%	20	50	100		
T <sub>doff</sub>	Turn-off delay time to 80%	100	330	1000		
T <sub>f</sub>	Fall time 80% to 20%	30	70	150		
E <sub>on</sub> + E <sub>off</sub>	Turn on and off energy	—	5	—	mJ	

## Protection Characteristics

Symbol	Parameter	Min.	Typ.	Max.	Units	Test Conditions
T <sub>sd</sub>	Over temperature threshold	150(2)	165	—	°C	See figure 1
I <sub>sd</sub>	Over current threshold	60	85	110	A	See figure 1
OV	Over voltage protection (not active when the device is ON )	34	37	—	V	
V <sub>reset</sub>	IN protection reset threshold	—	1.7	—	V	
T <sub>reset</sub>	Time to reset protection	15(2)	50	200	μs	V <sub>in</sub> =0V

## Diagnostic

Symbol	Parameter	Min.	Typ.	Max.	Units	Test Conditions
I <sub>in, on</sub>	ON state IN positive current	15	32	70	μA	V <sub>in</sub> =5V
I <sub>in, off</sub>	OFF state IN positive current (after protection latched )	150	230	350		V <sub>in</sub> =5V

(2) Guaranteed by design

## Lead Assignments

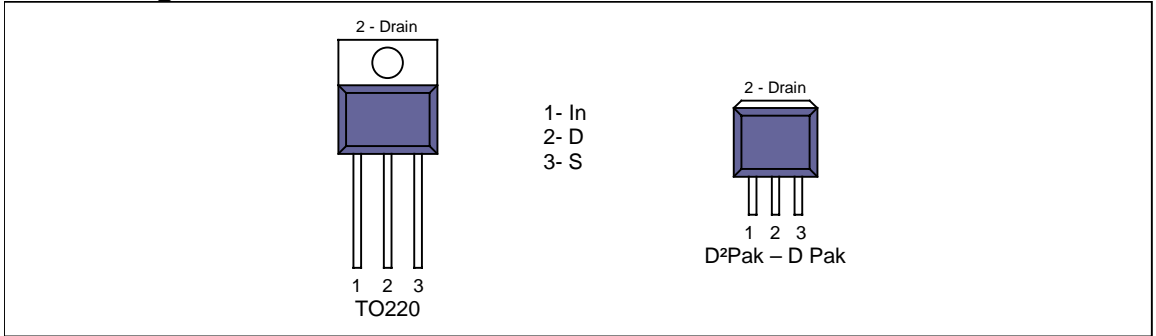

## Functional Block Diagram

All values are typical

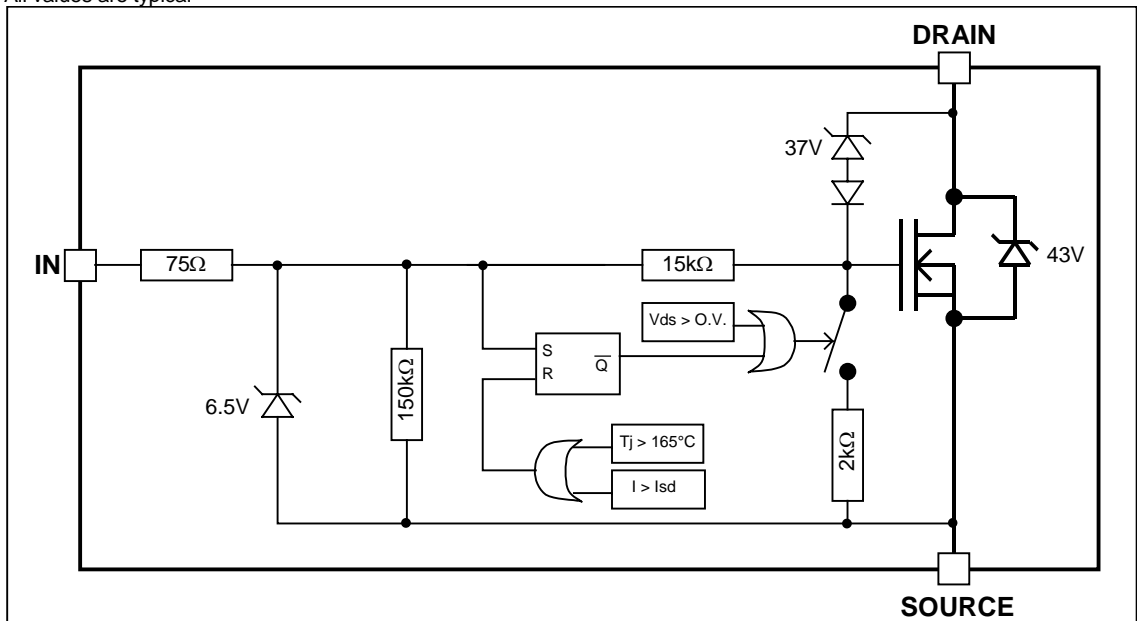

All curves are typical values. Operating in the shaded area is not recommended.

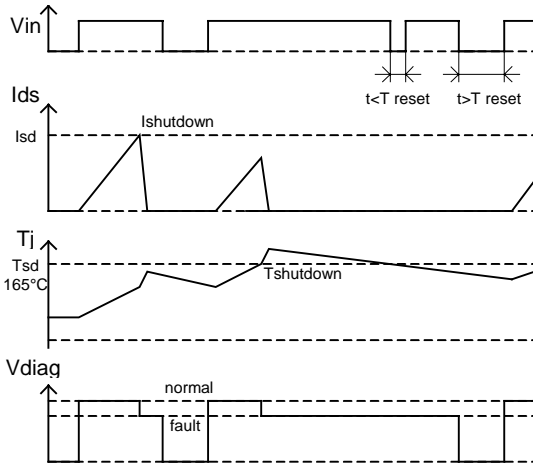

Figure 1 – Timing diagram

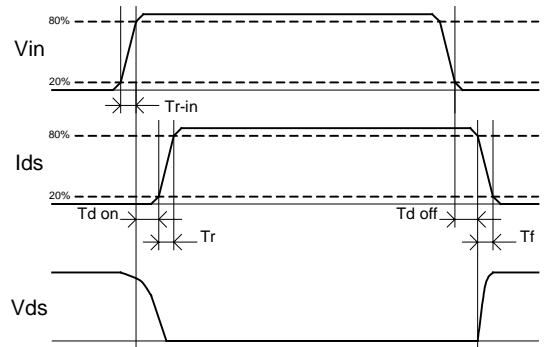

Figure 2 – IN rise time & switching definitions

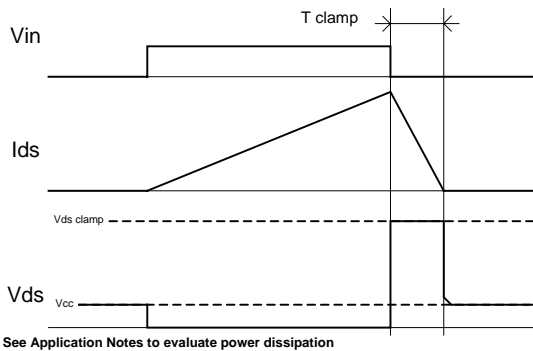

Figure 3 – Active clamp waveforms

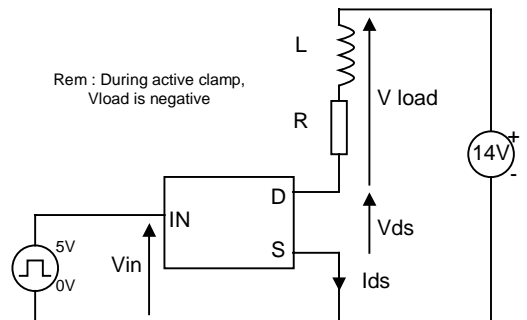
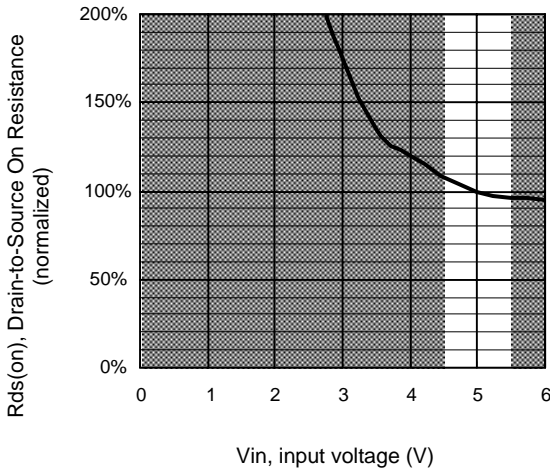
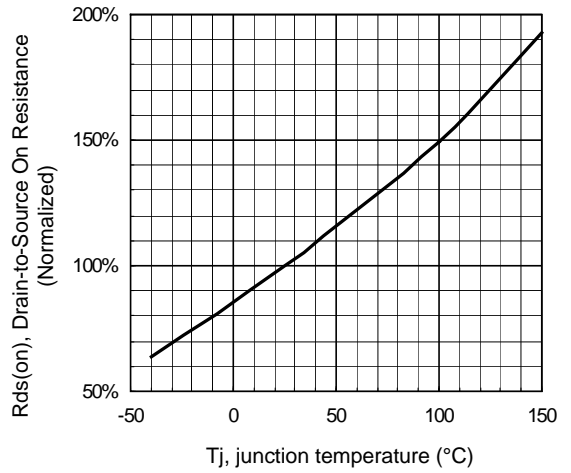

Figure 4 – Active clamp test circuit



**Figure 5 – Normalized R<sub>ds(on)</sub> (%) Vs Input voltage (V)**



**Figure 6 - Normalized R<sub>ds(on)</sub> (%) Vs T<sub>j</sub> (°C)**

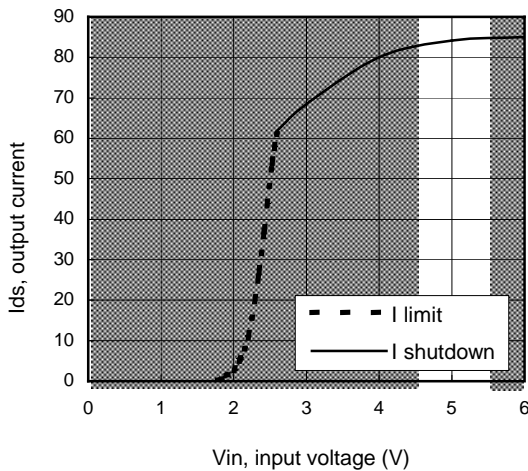

**Figure 7 – Current limitation and current shutdown Vs Input voltage (V)**

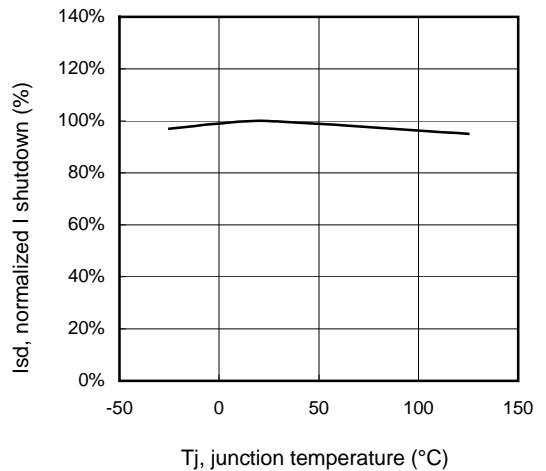

**Figure 8 – Normalized I shutdown (%) Vs junction temperature (°C)**

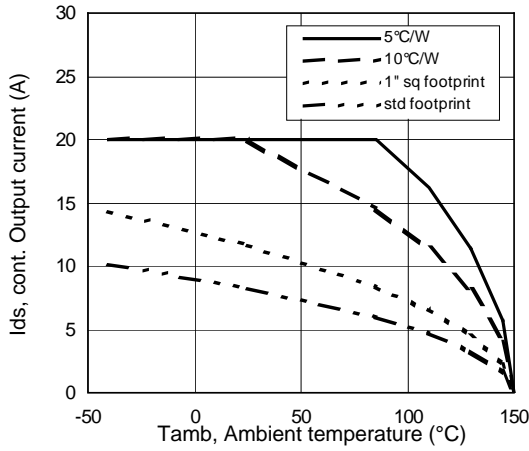

**Figure 9 – Max. continuous output current (A) Vs Ambient temperature (°C)**

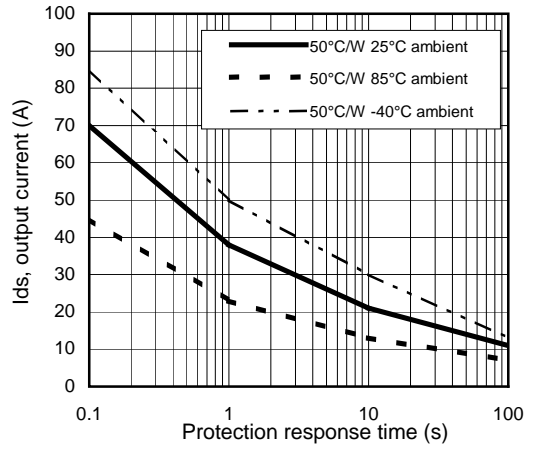

**Figure 10 – Ids (A) Vs over temperature protection response time (s)**

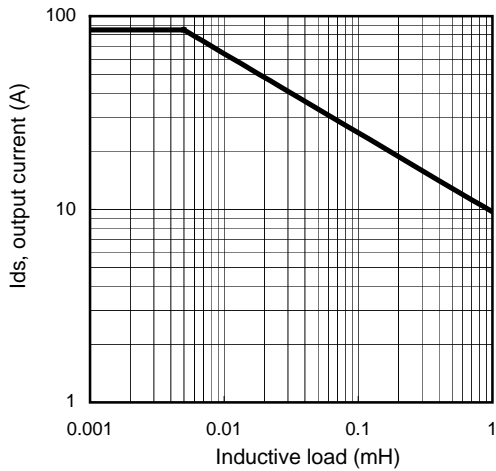

**Figure 11 – Max. output current (A) Vs Inductive load (mH)**

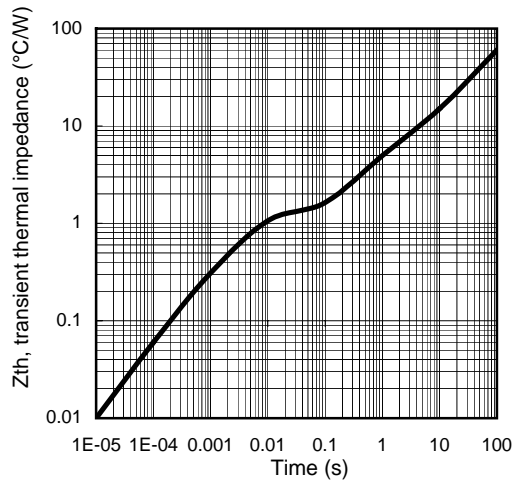

**Figure 12 – Transient thermal impedance (°C/W) Vs time (s)**

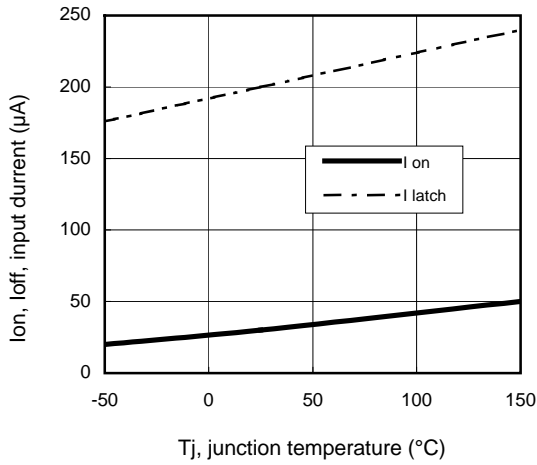

**Figure 13 – Input current (µA) On and Off Vs junction temperature (°C)**

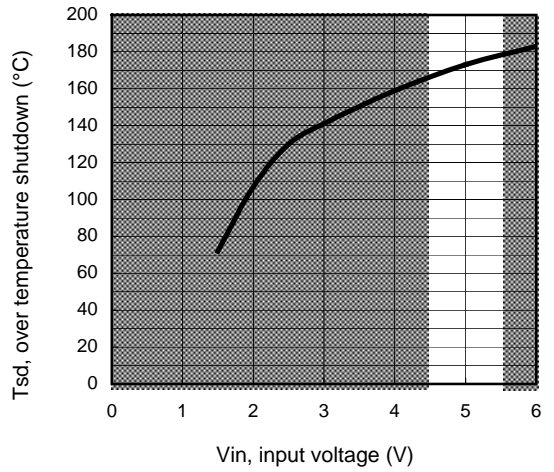

**Figure 14 – Over temperature shutdown (°C) Vs input voltage (V)**



## Case Outline – TO-220 AB

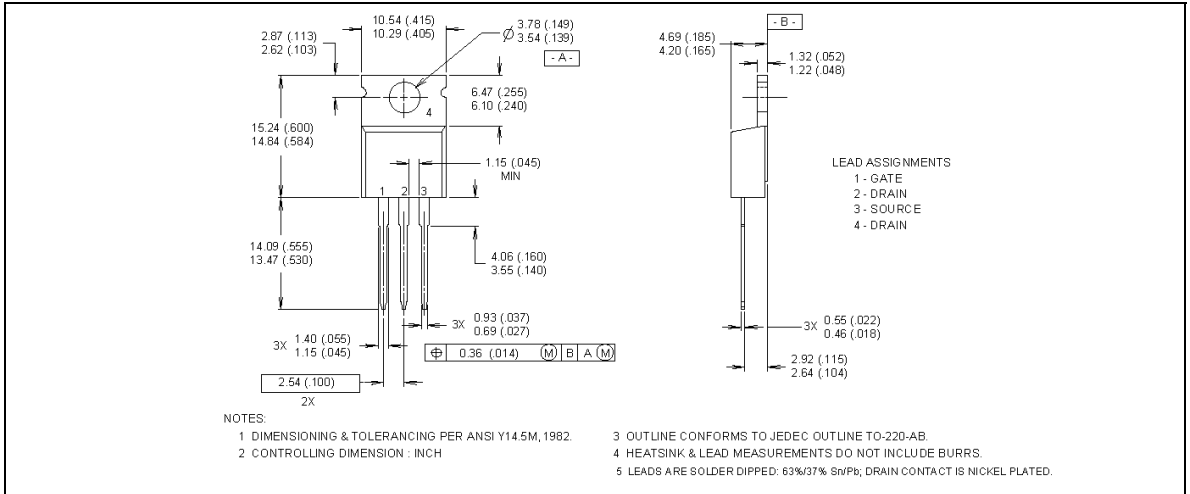

## Case Outline - D<sup>2</sup>Pak (SMD-220)

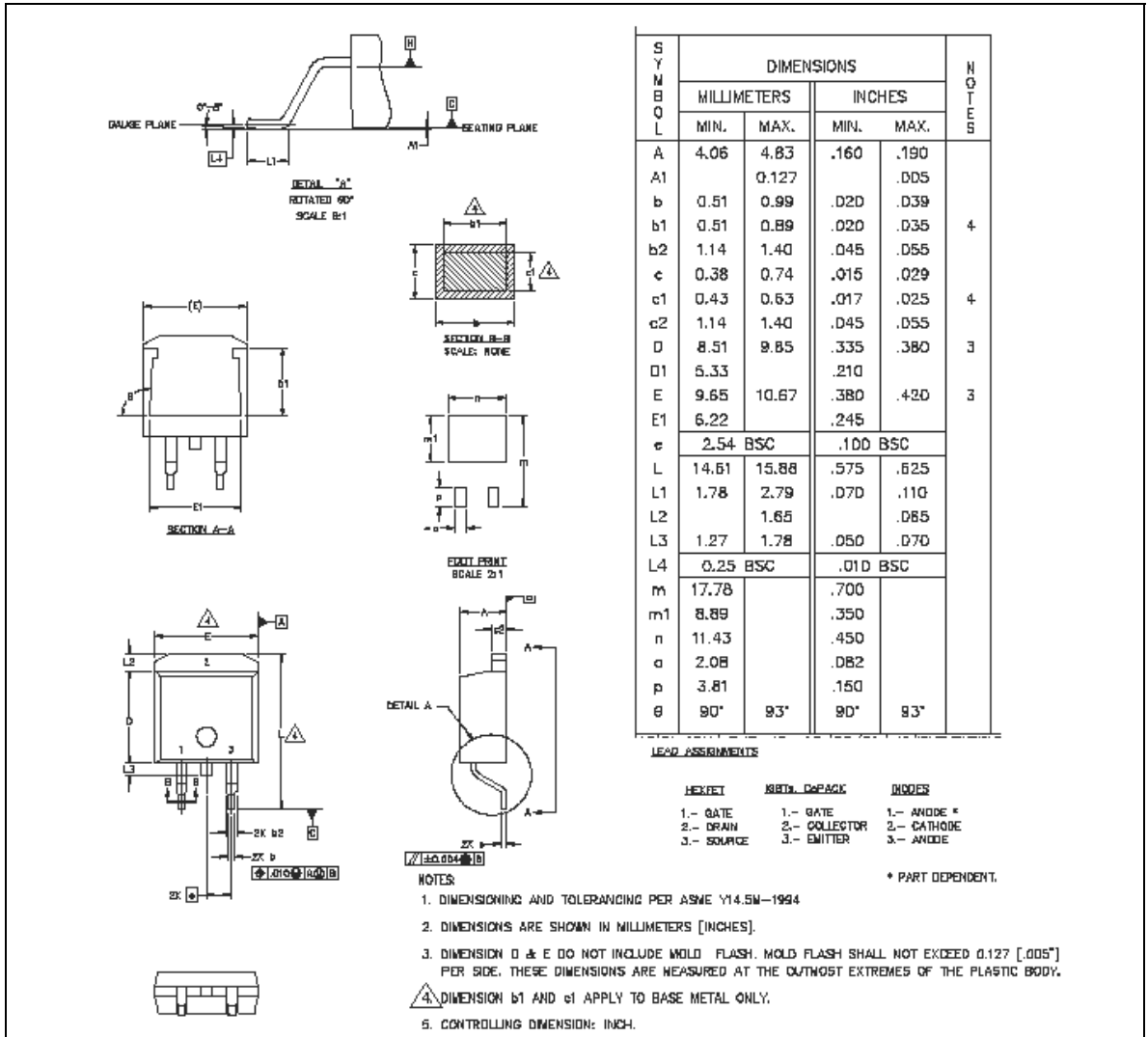

**Case Outline – D-Pak**

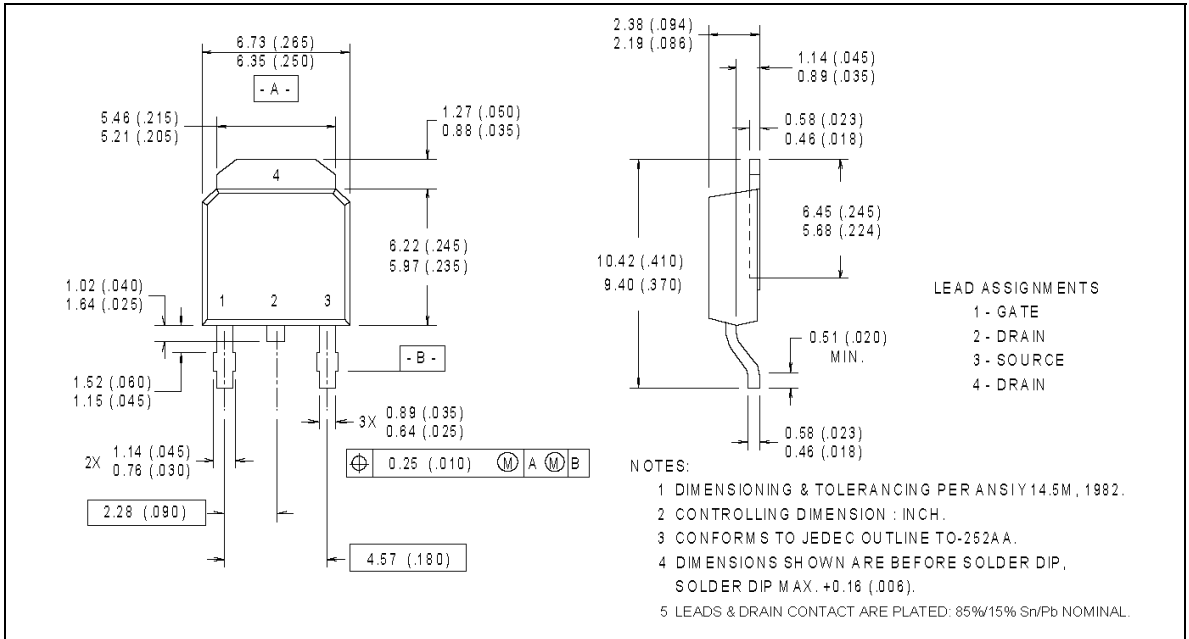

## Tape & Reel - D<sup>2</sup>Pak (SMD220)

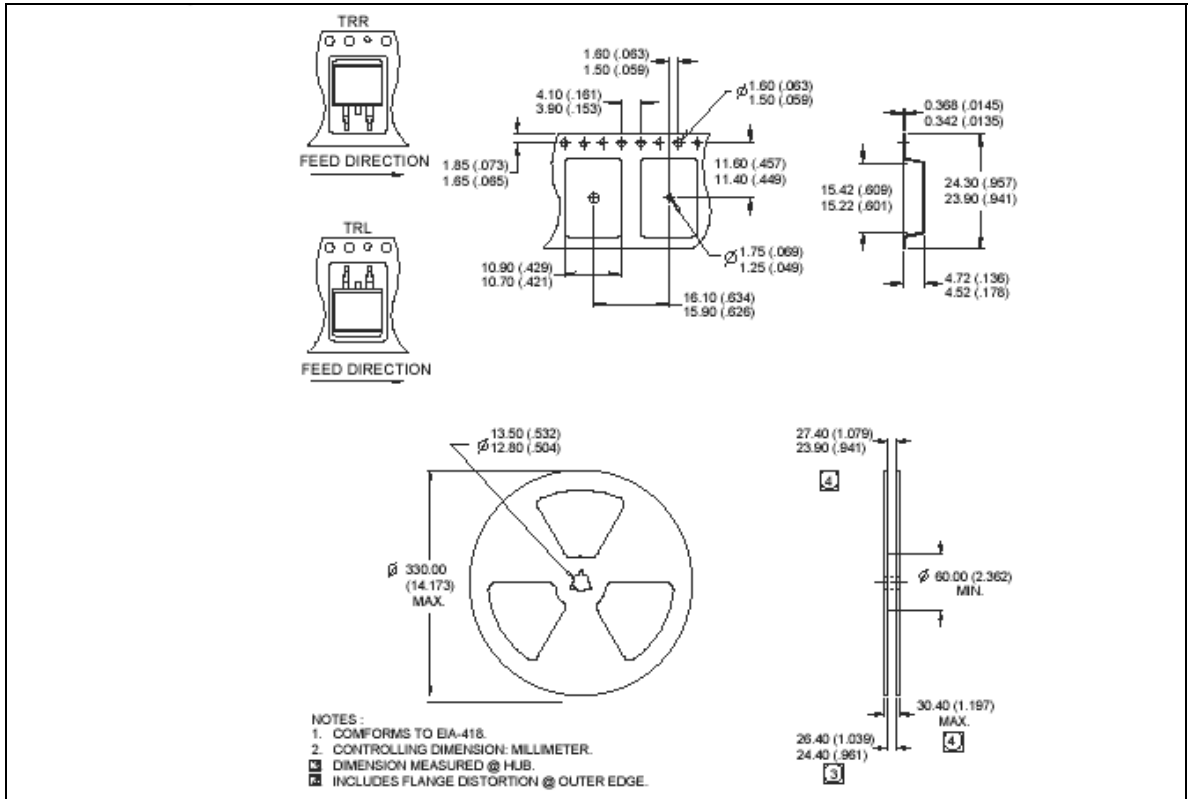

## Tape & Reel - D-Pak

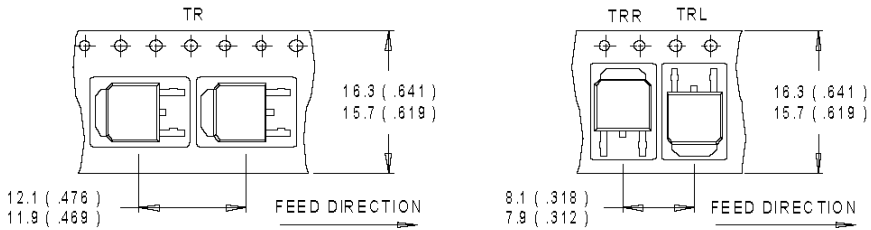

NOTES :

1. CONTROLLING DIMENSION : MILLIMETER.
2. ALL DIMENSIONS ARE SHOWN IN MILLIMETERS ( INCHES ).
3. OUTLINE CONFORMS TO EIA-481 & EIA-541.

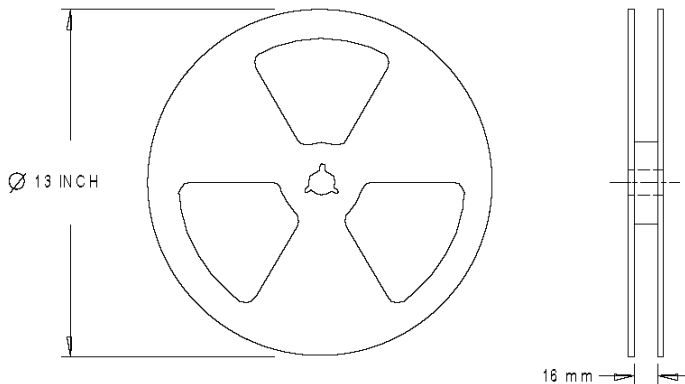

NOTES :

1. OUTLINE CONFORMS TO EIA-481.

Dimensions are shown in millimeters (inches)