

5V FR-4 Based Surface Mount Voltage Controlled Crystal Oscillators

- FR-4 Based SMT
- 70 to 170MHz Frequency Range
- -10°C to 70°C Operating Temperature
- Sine Wave Output
- Uses Champion's Proprietary I-Mesa Crystal Technology



P
R
E
L
I
M
I
N
A
R
Y

ELECTRICAL SPECIFICATIONS

Model	F1400AA	
Frequency Range (MHz)	70 - 170	
Input Current (mA)	< 40	
Frequency Control Function	(For Custom Deviation Range, Vc Range, etc. - Consult Factory)	
Deviation (ppm)		
Minimum	±60	
Maximum	±120	
Linearity (%)	< 10	
Modulation Bandwidth (±3dB)	> 10KHz	
Nominal Control Voltage (V)	2.5	
Control Voltage Range (V)	0.5 to 4.5	
Transfer Function	Positive	
Input Impedance	> 50KΩ @ 10KHz	
Frequency Stability (ppm)		
Overall	Inclusive of Calibration, Temperature, Voltage, Load and Aging	
(1Year)	±35	
(15 years @ 55°C)	±45	
Temperature Range (°C)		
Operating	-10°C to +70°C	
Storage	-40°C to +85°C	
Supply Voltage (V)	+5.0V ±5%	
Leakage Current (mA)	200nA (Pin1, Vc = 4.5V)	
Start Up Time (ms)	<10	
Output Signal	Sinewave	
Load	50Ω	
Output Power(dBm)	+3 ±3	
Harmonics (dBc)	< -20	
Sub-Harmonics & Spurious Modes (dBc)	< -70	
Typical SSB Phase Noise (dBc/Hz)	100Hz	-60
Offset from Carrier	1KHz	-90
	10KHz	-120
	100KHz	-145

PART NUMBERING GUIDE

F1400AA - Specify Frequency

5V FR-4 Based Surface Mount Voltage Controlled Crystal Oscillators

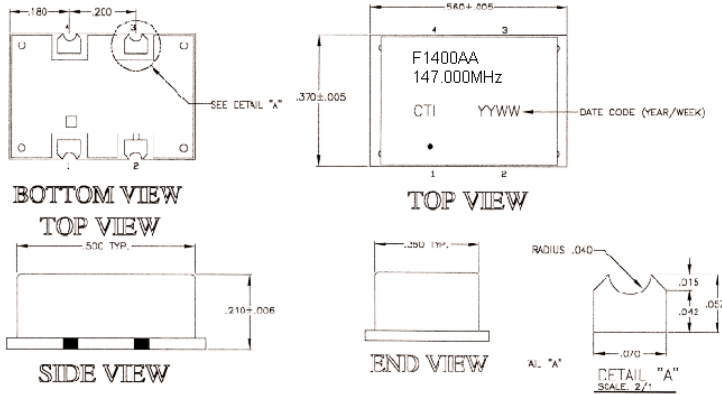

PIN	FUNCTION
1	Voltage Control
2	Gnd/ & Case Gnd
3	Output
4	+ V _{CC}

P
R
E
L
I
M
I
N
A
R
Y

MECHANICAL AND ENVIRONMENTAL SPECIFICATIONS

TEST METHODS	REFERENCE PROCEDURES	DESCRIPTION
Temperature Cycle	MIL-STD-833, Mtd 1010, Cond. B	-55°C to +125°C; Air-to-Air; 100 cycles; 10 min. dwell
Mechanical Shock	MIL-STD-883, Mtd 2002, Cond. B	1500 g's
Vibration	MIL-STD 883, Mtd 2007, Cond. B	20-2000 Hz; 0.06 inch; 15g's; 3 planes
Humidity Steady State	MIL-STD-202, Mtd 103	40°C; 90%-95% R.H.; 56 days
Thermal Shock	MIL-STD-883, Mtd 1011.7 Cond. B	100°C to 0°C; Water-to-Water; 15 cycles
Electrostatic Discharge	MIL-STD-883, Mtd 3015 Class II	2 KV to 4 KV Threshold
Solderability	MIL-STD-883, Mtd 2022.2	Solder dip; Meniscograph Criteria
Hermeticity	MIL-STD-883, Mtd 1014.8, Cond. A1	Mass spectro. 2 x 10-8 atmos. CC/sec He
Resistance to Soldering	MIL-STD-202, Mtd 210D, Cond. C	260°C; 10 seconds: 1 inch/sec.
Lead Integrity	MIL-STD-883, Mtd 2004.5, Cond. A, B1	Lead tension & bend stress
Marking Permanence	MIL-STD-883, Mtd 2015.8	Resistance to solvents
Life Test	MIL-STD-883, Mtd 1005.6	125°C, powered, 1000 hours minimum

2553 N. Edgington Street, Franklin Park, IL 60131 • Phone: 847.451.1000 • Fax: 847.451.7585