

MD1822 + TC7920: Three Level High Speed $\pm 100V$ 2.0A Pulser Demoboard

Demoboard Features

- ▶ Ultrasound high voltage & high current RTZ pulser
- ▶ MD1822 driving TC7920 with two pairs of MOSFETs
- ▶ 3-level voltage pulse waveform outputs
- ▶ $\pm 2.0A$ source and sink current capability
- ▶ 40 MHz frequency clock on board
- ▶ Programmable logic waveform generation
- ▶ JTAG connection for CPLD programming
- ▶ Connectors for external clock and signals
- ▶ 3.3V CMOS logic interface

Applications

- ▶ Medical ultrasound imaging
- ▶ Piezoelectric transducer drivers
- ▶ Material flaw detection
- ▶ ATE and waveform generator
- ▶ Transducer power driver
- ▶ Capacitive and MEMS sensor driver
- ▶ Ultrasonic NDT detection and sonar ranger

General Description

The MD1822DB1 is a demoboard for the three level $\pm 100V$ 2.5A pulser chip-set of the MD1822 MOSFET driver and the TC7920 MOSFET. The demoboard consists of one MD1822 in the 3x3mm 16-lead QFN package driving the TC7920 which has two pairs of high speed and high voltage complementary P- and N-MOSFETs in in one 4x4mm, 8-lead DFN package. This circuit is an ideal, cost-optimized, high voltage and high current RTZ ultrasound transmit pulser.

The CPLD-programmable logic circuit (40 MHz crystal oscillator) generates accurately timed high-speed waveforms on a separate CPL board. Multiple frequency and waveform combinations can be selected as bipolar pulse waveforms. An external clock input can be used if the on-board oscillator is disabled. The external trigger input can be used to synchronize the output waveforms. There are five push buttons for selecting demonstration waveform, frequency, phase, and mode functions. Color LEDs indicate the demo selection states. Jumpers on the board can select either the 330pF/2.5k on-board load, or user test loads.

Block Diagram

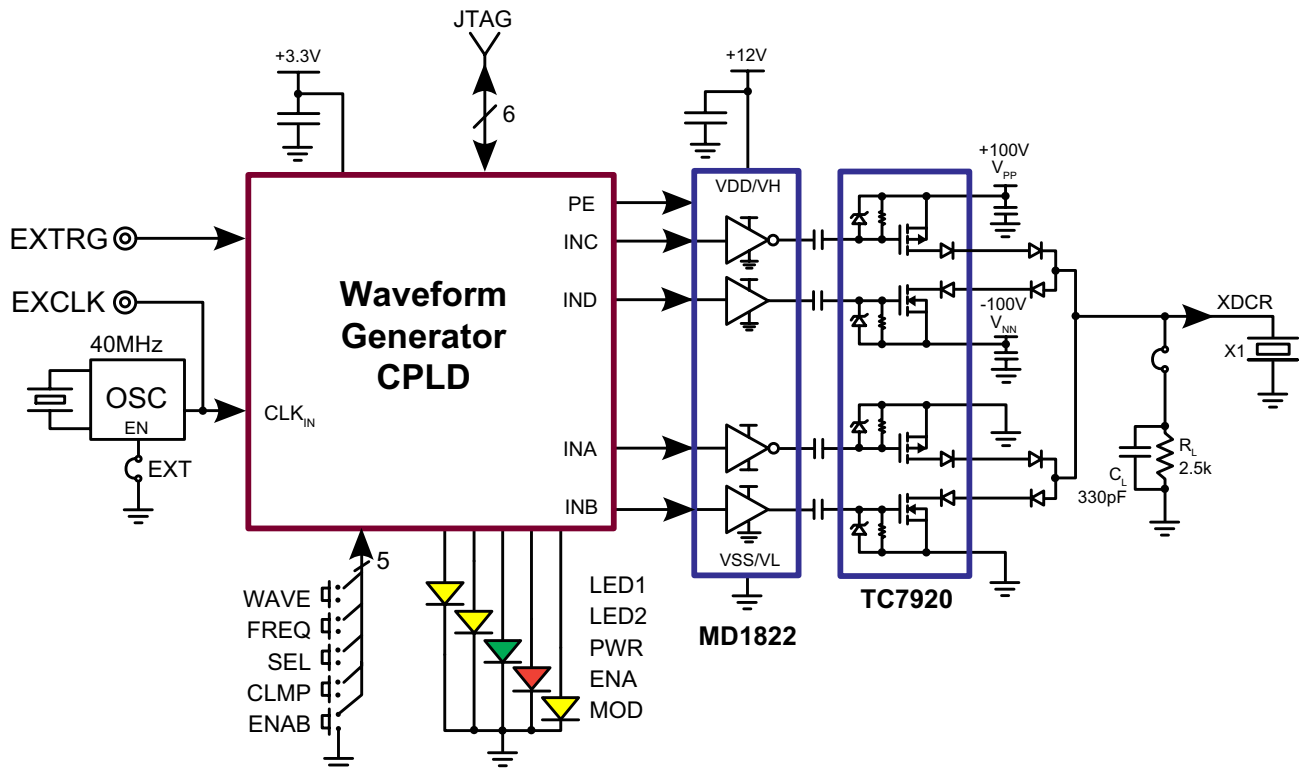

MD1822DB1 Board and PCB Layout

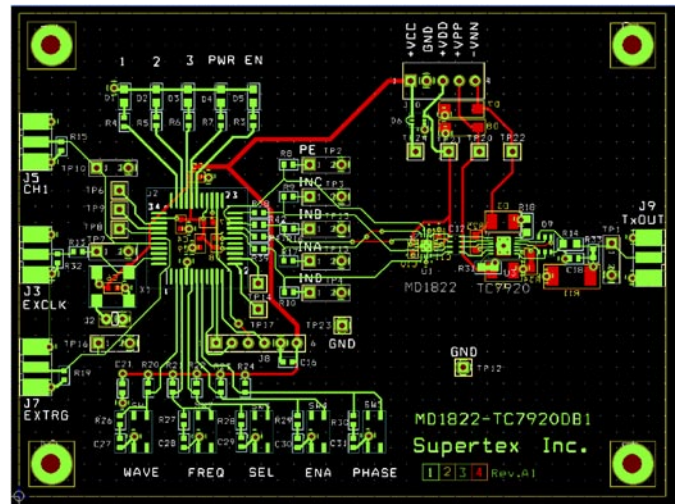
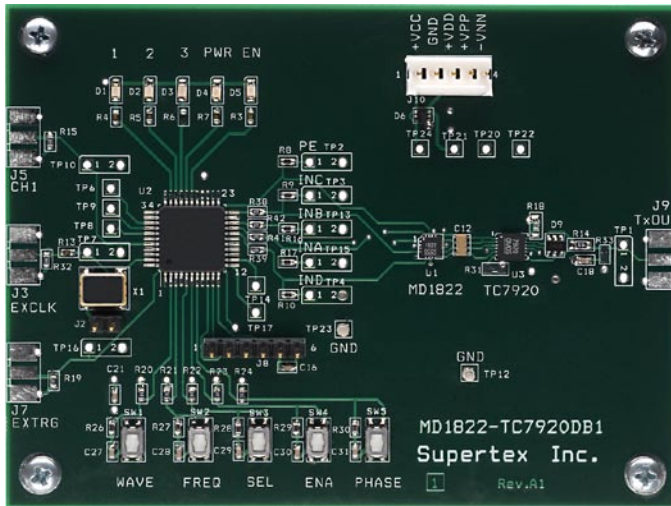

Actual size = 100mm x 70mm

Operating Supply Voltages and Current (on J10)

Symbol	Parameter	Min	Typ	Max	Units	Suggested Current Limit *
VCC	Logic supply	1.8	3.3	3.3	V	150mA
GND	Circuit Ground or 0V	-	0	-	V	---
VDD	MD1822 Positive Supply	5.0	10	11.5	V	10mA
VPP	TC7920 HV positive supply	0	-	100	V	5.0mA
V _{NN}	TC7920 HV negative supply	-100	-	0	V	5.0mA

Note:

* Current limits should be changed according the testing waveform, frequency and duty cycles.

Push Button Operation Functions

Button Symbol	Description
WAVE	Demo waveforms selection
FREQ	Demo waveform frequency selection
SEL	Not Used
ENA	MD1822 PE pin control
PHASE	Not Used

Schematic Diagram

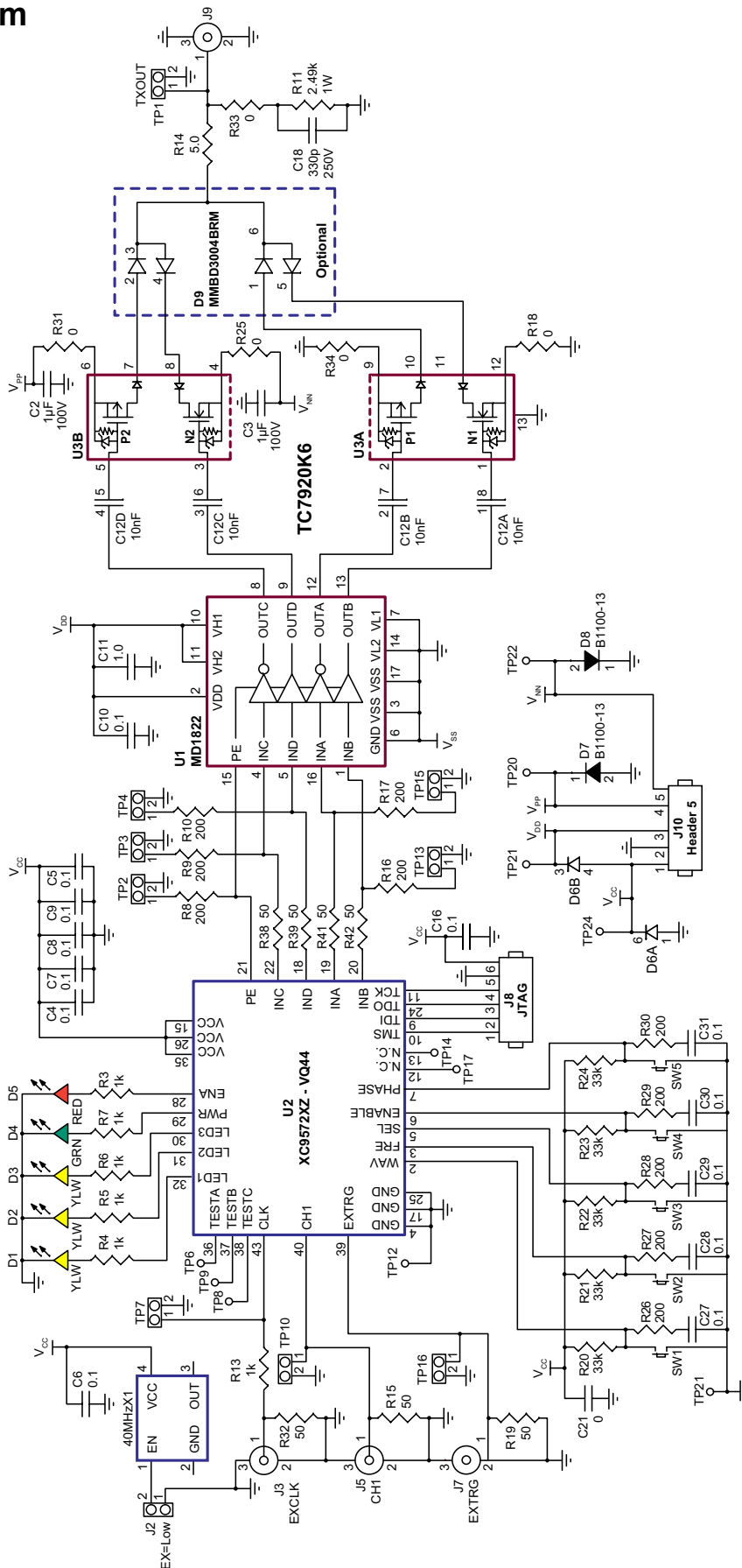

Demo Waveforms

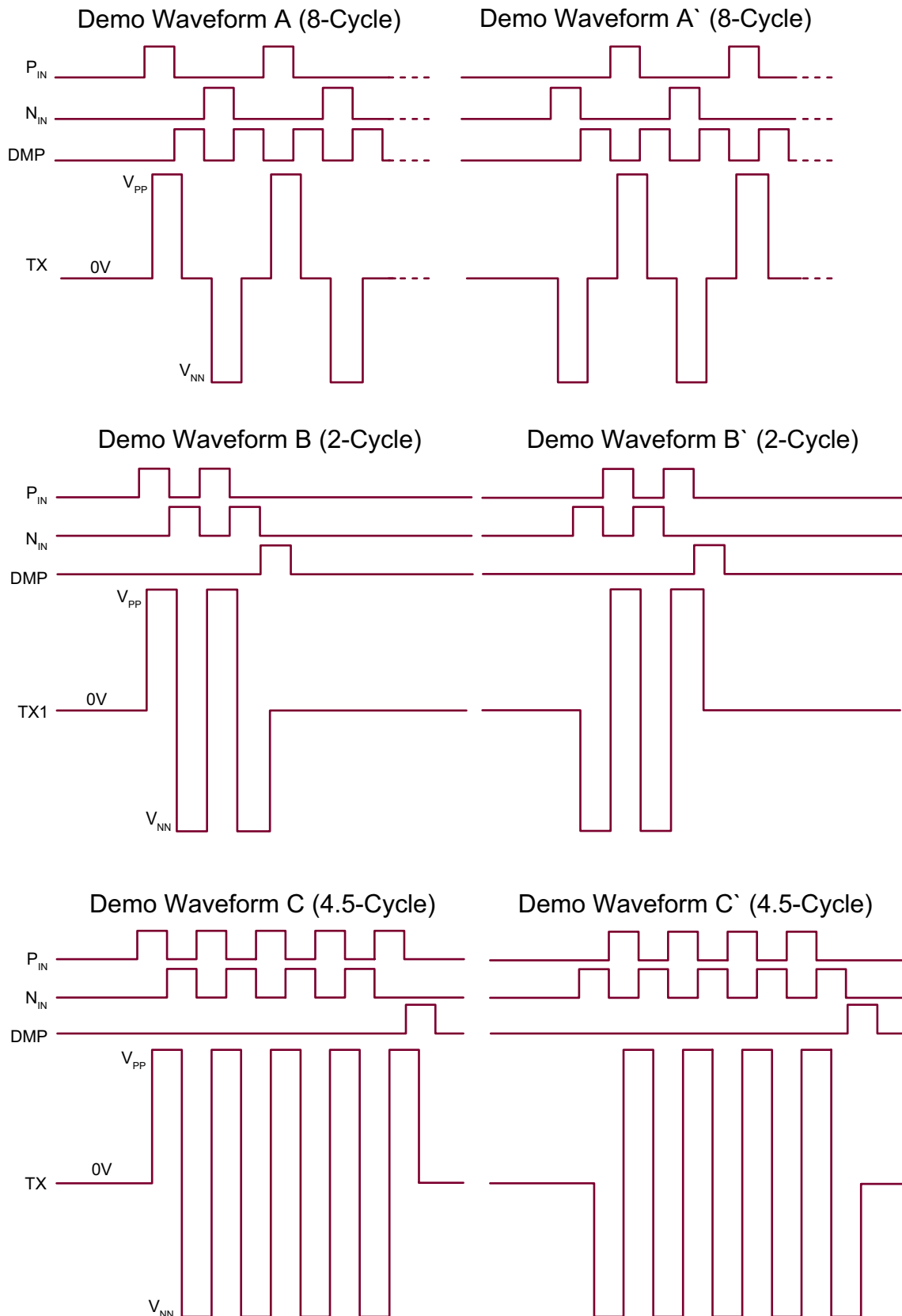

Demo Waveforms (cont.)

Demo Waveform D (8-Cycle w/o Damping)

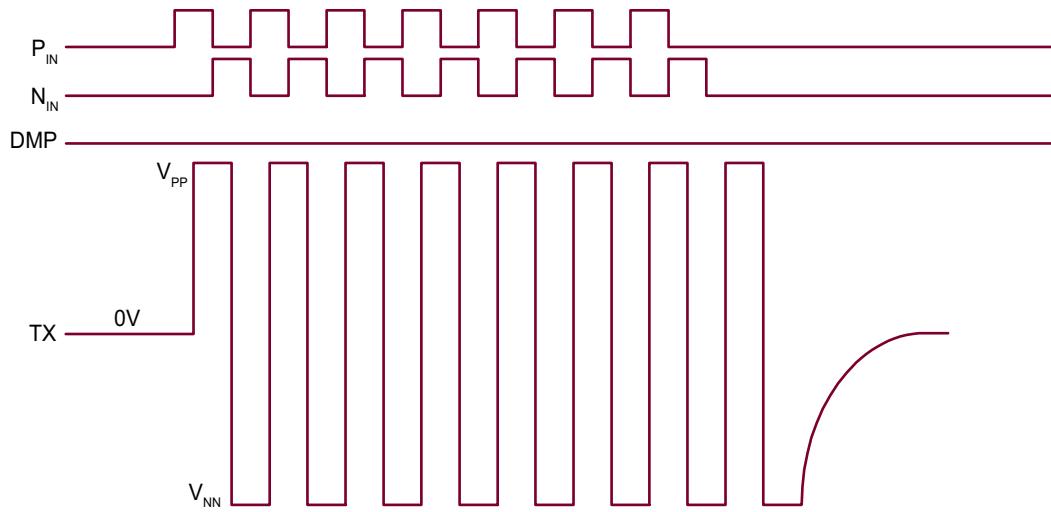

Demo Waveform E (16-Cycle w/o Damping)

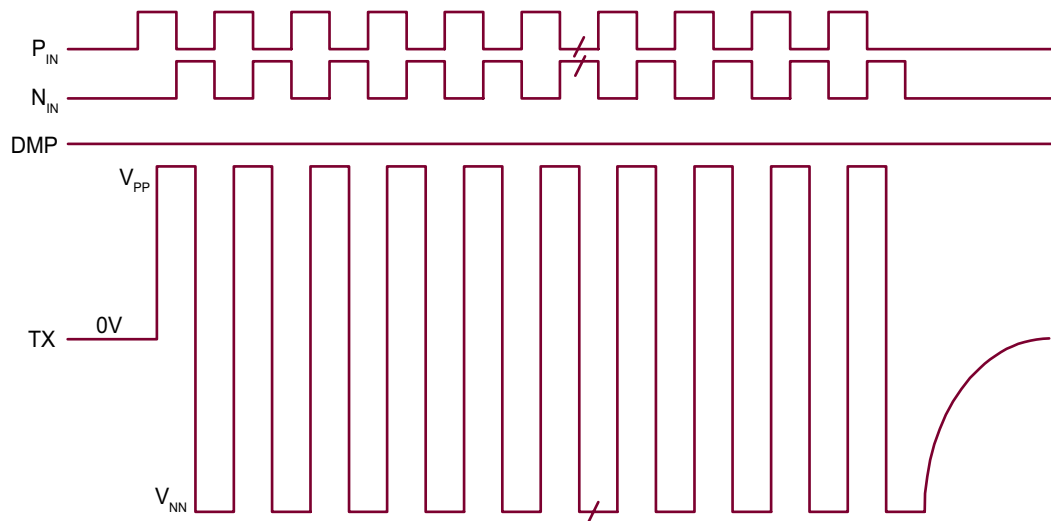

Test Waveforms

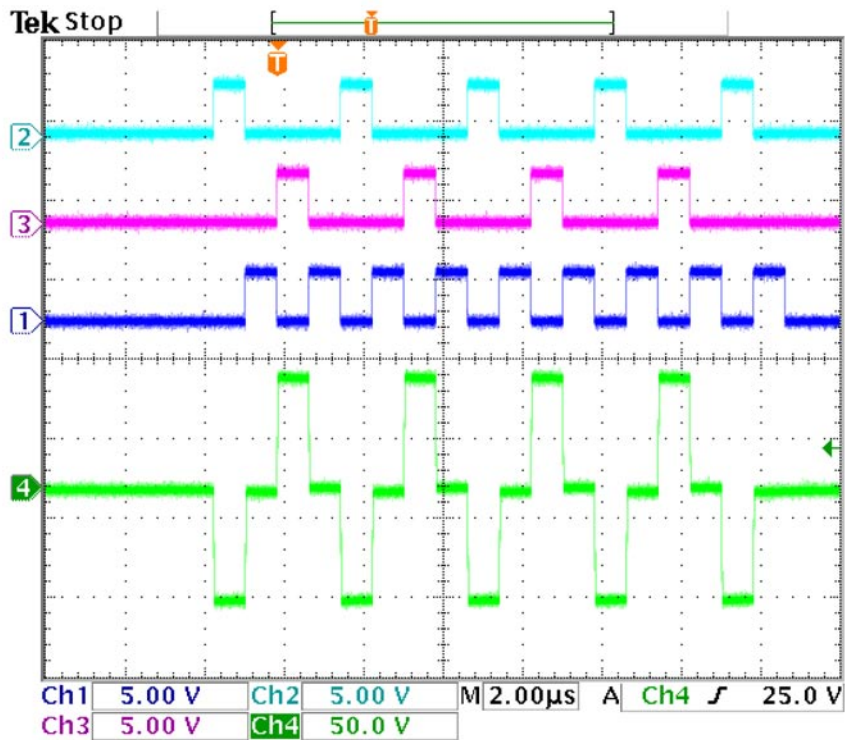

Fig 1: Input and output waveforms at $V_{DD} = 10V$, $V_{PP}/V_{NN} = \pm 70V$, Load = 330pF//2.5k.

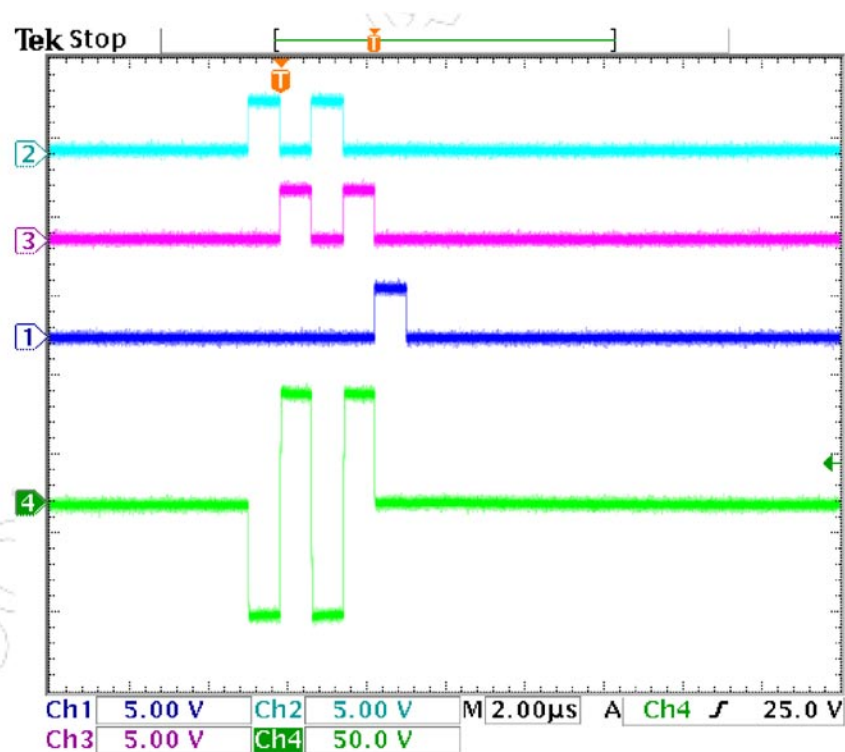

Fig 2: Input and output waveforms at $V_{DD} = 10V$, $V_{PP}/V_{NN} = \pm 70V$, Load = 330pF//2.5k.

Test Waveforms (cont.)

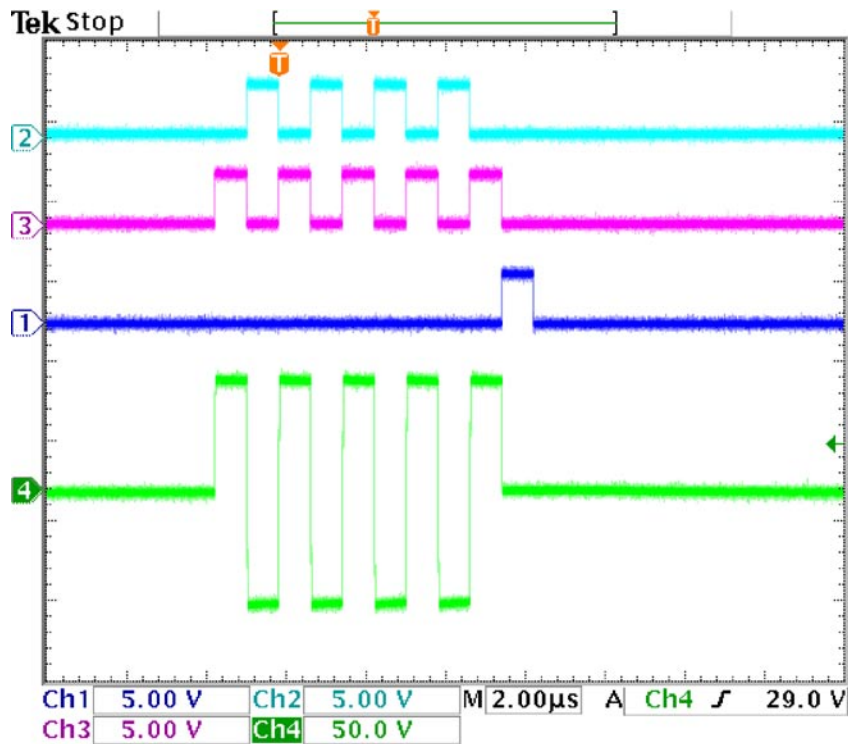

Fig 3: Input and output waveforms at $V_{DD}=10V$, $V_{PP}/V_{NN} = \pm 70V$, Load = 330pF//2.5k.

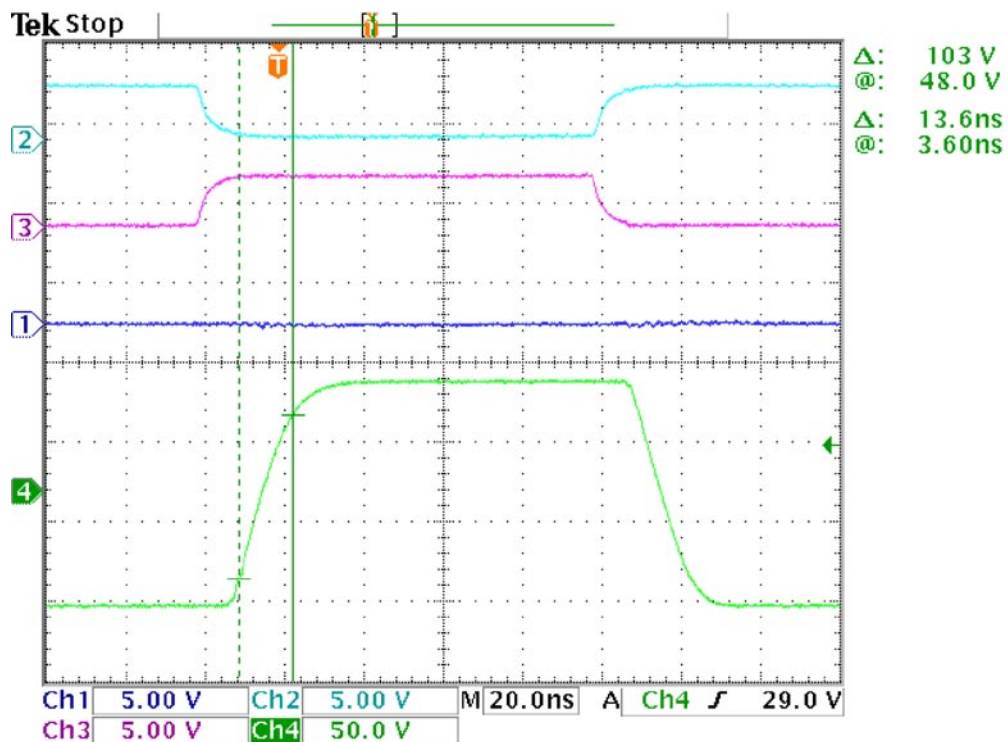

Fig 4: Input to output delay and rise time of output at $V_{DD} = 10V$, $V_{PP}/V_{NN} = \pm 70V$, Load = 330pF//2.5k,
 $I_{OUT} = 330pF(103V/13.6ns) = 2.5A$.

Test Waveforms (cont.)

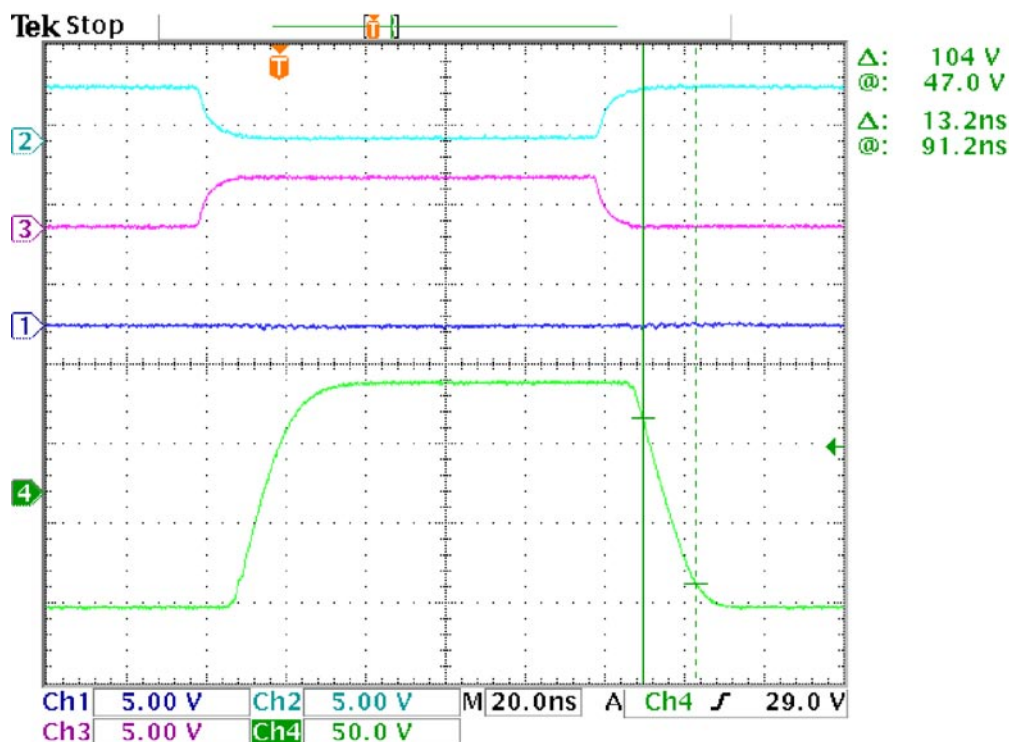

Fig 5: Input to output delay and fall time of output at $V_{DD} = 10V$, $V_{pp}/V_{NN} = \pm 70V$, Load = 330pF//2.5k, $I_{OUT} = 330pF(104V/13.2ns) = 2.5A$.

JTAG or Boundary Scan Mode

JTAG or Boundary Scan mode is an industry standard (IEEE 1149.1, or 1532) serial programming mode. External logic from a cable, microprocessor, or other device is used to drive the JTAG specific pins, Test Data Out (TDO), Test Data

In (TDI), Test Mode Select (TMS), and Test Clock (TCK). This mode has gained popularity due to its standardization and ability to program CPLD through the same four JTAG pins. The data in this mode is loaded at one bit per TCK.

JTAG Connector	Pin Number	Description
J8-1	TMS	Test Mode Select of CPLD.
J8-2	TDI	Test Data In of CPLD.
J8-3	TDO	Test Data Out of CPLD.
J8-4	TCK	Test Clock of CPLD.
J8-5	GND	Logic Power Supply Ground 0V for programming and testing only.
J8-6	VCC	Logic Power Supply +3.3V for CPLD programming or testing only.

Supertex inc. does not recommend the use of its products in life support applications, and will not knowingly sell them for use in such applications unless it receives an adequate "product liability indemnification insurance agreement." **Supertex inc.** does not assume responsibility for use of devices described, and limits its liability to the replacement of the devices determined defective due to workmanship. No responsibility is assumed for possible omissions and inaccuracies. Circuitry and specifications are subject to change without notice. For the latest product specifications refer to the **Supertex inc.** (website: <http://www.supertex.com>)