

Spec. No.	413-212-091
Version :	1
Total pages :	26
Date :	2001.May.29

UNIPAC 1.8" COLOR TFT-LCD MODULE

MODEL NAME: UP018D02-1

The content of this technical information is subject to change without notice. Please contact Unipac or its agent for further information.

Approved by	Checked by	Prepared by

Contents:

A. Physical specification.....	P3
B. Electrical specifications.....	P4
1. Pin assignment.....	P4
a. TFT-LCD panel driving section.....	P5
b. Backlight driving section.....	P6
2. Absolute maximum ratings.....	P6
3. Electrical characteristics.....	P6
a. Typical operating conditions.....	P6
b. Current consumption.....	P7
c. Backlight driving conditions.....	P7
4. AC Timing.....	P8
a. Timing conditions.....	P8
b. Timing diagram.....	P8
C. Optical specifications.....	P9
D. Reliability test items.....	P12
E. Packing form.....	P14



Appendix:

Fig.1 Outline dimension of TFT-LCD module.....	P 15
Fig.2 Sampling clock timing.....	P 16
Fig.3 Horizontal display timing range (Normal scanning mode).....	P 17
Fig.4 - (a) Horizontal timing.	P 18
Fig.4-(b) Detail horizontal timing.....	P 19
Fig.5 Vertical shift clock timing.....	P 20
Fig.6-(a) Vertical timing (Normal scanning mode).....	P 21
Fig.6-(b) Vertical timing (Reverse scanning mode).....	P 22
Incoming inspection standard	P 23

A. Physical specifications

NO.	Item	Specification	Remark
1	Display resolution(dot)	280(W) × 220(H)	
2	Active area(mm)	35.6(W) × 26.6(H)	
3	Screen size(inch)	1.75(Diagonal)	
4	Dot pitch(mm)	0.127(W) × 0.121(H)	
5	Color configuration	R. G. B. delta	
6	Overall dimension(mm)	48.6(W) × 39.6(H) × 6.1(D)	Note 1
7	Weight(g)	20 ± 5	
8	Panel Surface treatment	Hard coating (3H)	

Note 1: Refer to Fig. 1

B. Electrical specifications

1.Pin assignment

a. TFT-LCD panel driving section

Pin no	Symbol	I/O	Description	Remark
1	GND	-	Ground for logic circuit	
2	V _{CC1}	I	Supply voltage of logic control circuit for scan driver	Note 3
3	V _{GL}	I	Negative power for scan driver	Note 3
4	V _{GH}	I	Positive power for scan driver	Note 3
5	STVR	I/O	Vertical start pulse	Note 1,3,4
6	STVL	I/O	Vertical start pulse	Note 1,3,4
7	CKV	I	Shift clock input for scan driver	Note 3
8	U/D	I	Up/Down scan control input	Note 1,2,3
9	OEV	I	Output enable input for scan driver	Note 3
10	VCOM	I	Common electrode driving signal	Note 7
11	VCOM	I	Common electrode driving signal	Note 7
12	L/R	I	Left/Right scan control input	Note 1,2,5
13	Q1H	I	Analog signal rotate input	Note 5
14	OEH	I	Output enable input for data driver	Note 5
15	STHL	I/O	Start pulse for horizontal scan line	Note 1,5,6
16	STHR	I/O	Start pulse for horizontal scan line	Note 1,5,6
17	CPH3	I	Sampling and shifting clock pulse for data driver	Note 5
18	CPH2	I	Sampling and shifting clock pulse for data driver	Note 5
19	CPH1	I	Sampling and shifting clock pulse for data driver	Note 5
20	V _{CC2}	I	Supply voltage of logic control circuit for data driver	Note 5
21	GND	-	Ground for logic circuit	
22	VR	I	Alternated video signal input(Red)	Note 5
23	VG	I	Alternated video signal input(Green)	Note 5
24	VB	I	Alternated video signal input(Blue)	Note 5
25	AV _{DD}	I	Supply voltage for analog circuit	Note 5
26	AV _{SS}	-	Ground for analog circuit	

Note 1: Selection of scanning mode

Mode	Setting of scan control input		IN/OUT state For start pulse				Scanning direction
	U/D	L/R	STVR	STVL	STHR	STHL	
Normal mode	L	H	OUT	IN	OUT	IN	From up to down, and from left to right.
Reverse mode	H	L	IN	OUT	IN	OUT	From down to up, and from right to left.

IN: Input; OUT: Output.

Note 2 : Definition of scanning direction.

Refer to figure as below:

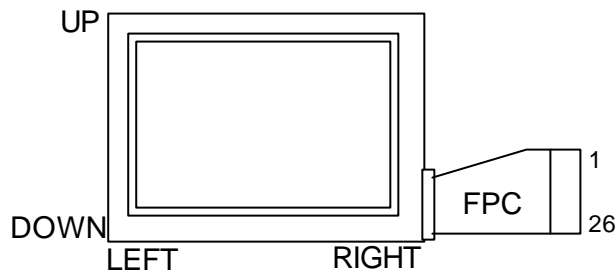

Note 3 : Input equivalent circuit

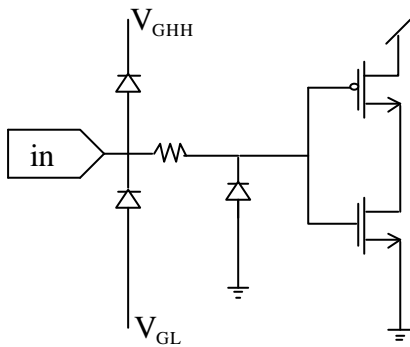

Note 4 : Output equivalent circuit

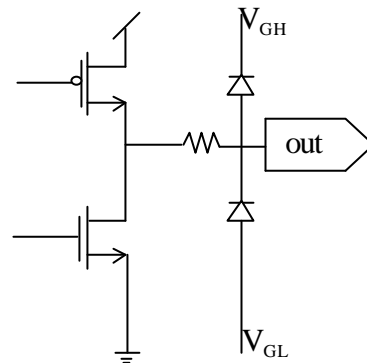

Note 5 : Input equivalent circuit

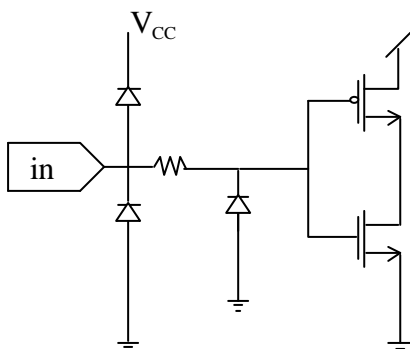

Note 6 : Output equivalent circuit

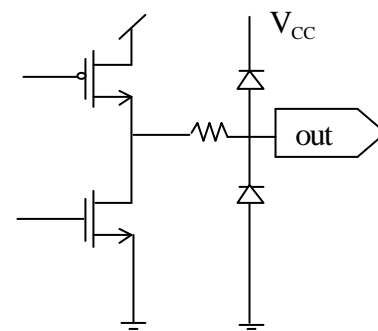

Note 7 : Input equivalent circuit

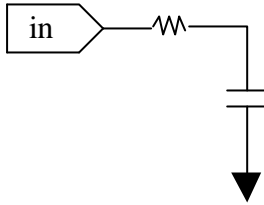

b. Backlight driving section (Refer to Fig.1)

No.	Symbol	I/O	Description	Remark
1	HI		Power supply for backlight unit (High voltage)	
2	GND	-	Ground	

2. Absolute maximum ratings

Item	Symbol	Condition	Min.	Max.	Unit	Remark
Power voltage	V_{CC}	GND=0	-0.3	7	V	V_{CC1}, V_{CC2}
	AV_{DD}	$AV_{SS}=0$	-0.3	7	V	
	V_{GH}	GND=0	-0.3	21	V	
	V_{GL}		-17	0.3	V	
	$V_{GH} - V_{GL}$		-	33	V	
Input signal voltage	V_i		-0.2	$V_{CC}+0.2$	V	Note 1
	V_i		-0.3	$V_{CC}+0.3$	V	Note 2
	VCOM		-2.9	5.2	V	
Operating temperature	Topa		0	60		Ambient temperature
Storage temperature	Tstg		-25	80		Ambient temperature

Note 1: VR, VG, VB.

Note 2: STHL, STHR, Q1H, OEH, L/R, CPH1~CPH3, STVR, STVL, OEV, CKV, U/D.

3. Electrical characteristics

a. Typical operating conditions (GND= $AV_{SS}=0V$)

Item	Symbol	Min.	Typ.	Max.	Unit	Remark
Power supply	V_{CC}	4.8	5	5.2	V	$V_{CC1} ; V_{CC2}$
	AV_{DD}	4.8	5	5.2	V	
	V_{GH}	14.3	15	15.7	V	
	$V_{GL AC}$	-	5.6	-	Vp-p	AC component of V_{GL} . Note 1
	V_{GL-H}	-10.5	-10	-9.5	V	High level of V_{GL} .
Video signal Amplitude (VR, VG, VB)	V_{Ia}	$AV_{SS} + 0.4$	-	$AV_{DD} - 0.4$	V	Note 2
	V_{IAC}	-	3	3.8	V	AC component
	V_{IDC}	-	$AV_{DD} / 2$	-	V	DC component

VCOM		V_{CAC}	-	5.6	-	Vp-p	AC component, Note 3
		V_{CDC}	1.05	1.35	1.65	V	DC component, Note 4
Input Signal voltage	H Level	V_{IH}	$0.8V_{CC}$	-	V_{CC}	V	Note 5
	L Level	V_{IL}	0	-	$0.2V_{CC}$	V	

Note 1: The same phase and amplitude with common electrode driving signal (VCOM).

Note 2: Refer to Fig.4 - (a).

Note 3: The brightness of LCD panel could be adjusted by the adjustment of the AC component of VCOM.

Note 4: V_{CDC} could be adjusted so as to minimize vertical straight line, flicker and maximum contrast on each module.

Note 5: STHL, STHR, Q1H, OEH, L/R, CPH1~CPH3, STVR, STVL, OEV, CKV, U/D.

Note 6: When V_{GH} , V_{GL} is on, V_{CC} could be off for 8 hours.

b. Current consumption (GND=AVss=0V)

Parameter	Symbol	Condition	Min.	Typ.	Max.	Unit	Remark
Current for driver	I_{GH}	$V_{GH}=15V$	-	0.3	0.8	mA	
	I_{GL}	$V_{GL-H}=-10V$	-	-0.6	-1	mA	
	I_{CC}	$V_{CC}=5V$	-	0.8	2	mA	V_{CC1} ; V_{CC2}
	I_{DD}	$AV_{DD}=5V$	-	2.5	8	mA	

c. Backlight driving conditions

Parameter	Symbol	Min.	Typ.	Max.	Unit	Remark
Lamp voltage	V_L	170	190	210	Vrms	
Lamp current	I_L	1.5	2.8	4.0	mArms	
Frequency	F_L	55	60	65	KHz	Note 3
Lamp starting voltage	V_S	-	-	375	Vrms	Note 1,4
		-	-	560	Vrms	Note 2,4
				630	Vrms	Note 6
				700	Vrms	Note 7
Lamp Life Time	L_L	10000			Hr	Note 1,5

Note 1 : $T_a = 25$.

Note 2 : $T_a = 0$.

Note 3 : The lamp frequency should be selected as different as possible from display horizontal synchronous signal (f_H) to avoid interference.(Even the frequency " $\frac{n}{2}f_H$ " should be avoided)

Note 4 : For starting the backlight unit, the output voltage of DC/AC' s transformer should be larger than the maximum lamp starting voltage.

Note 5 : Brightness to be decreased to the 50% of the initial value

Note 6 : $T_a = -10$.The lamp will be lighted on within 0.5 sec

Note 7 : $T_a = 25$.The backlight unit is placed in the dark room(0.1 lux) for 24 hour and then start to test.The lamp will be lighted on within **1 sec**.

4. AC Timing

a. Timing conditions

Parameter	Symbol	Min.	Typ.	Max.	Unit.	Remark
Rising time	t_r	-	-	10	ns	Note 1
Falling time	t_f	-	-	10	ns	Note 1
High and low level pulse width	t_{CPH}	450	500	550	ns	CPH1~CPH3
CPH pulse duty	t_{CWH}	40	50	60	%	CPH1~CPH3
CPH pulse delay	t_{C12} t_{C23} t_{C31}	70	$t_{CPH}/3$	$t_{CPH}/2$	ns	CPH1~CPH3
STH setup time	t_{SUH}	70	-	-	ns	STHR,STHL
STH hold time	t_{HDH}	350	-	-	ns	STHR,STHL
STH pulse width	t_{STH}	-	1	-	t_{CPH}	STHR,STHL
STH period	t_H	61.5	63.5	65.5	μs	STHR,STHL
OEH pulse width	t_{OEH}	-	3	-	t_{CPH}	OEH
Sample and hold disable time	t_{DIS1}	-	20	-	t_{CPH}	
OEV pulse width	t_{OEV}	-	5	-	t_{CPH}	OEV
CKV pulse width	t_{CKV}	2	6	10	t_{CPH}	CKV
Clean enable time	t_{DIS2}	-	4	-	t_{CPH}	
Horizontal display start	t_{SH}	-	4	-	$t_{CPH}/3$	
Horizontal display timing range	t_{DH}	-	280	-	$t_{CPH}/3$	
STV setup time	t_{SUV}	400	-	-	ns	STVL,STVR
STV hold time	t_{HDV}	400	-	-	ns	STVL,STVR
STV pulse width	t_{STV}	-	-	1	t_H	STVL,STVR
Horizontal lines per field	t_V	256	262	268	t_H	
Vertical display start	t_{SV}	-	10	-	t_H	
Vertical display timing range	t_{DV}	-	220	-	t_H	
VCOM rising time	t_{rCOM}	-	-	6	μs	
VCOM falling time	t_{fCOM}	-	-	6	μs	
VCOM delay time	t_{DCOM}	-	-	6	μs	
RGB delay time	t_{DRGB}	-	-	6	μs	

Note 1: For all of the logic signals.

b. Timing diagram

Please refer to the attached drawing, from Fig.2 to Fig.6.

C. Optical specification (Note 1,Note 2, Note 3)

Item	Symbol	Condition	Min.	Typ.	Max.	Unit	Remark
Response time	Rise	=0 °	-	25	50	ms	Note 4
	Fall		Tf	-	30	60	
Contrast ratio	CR	At optimized viewing angle	60	150	-		Note 5,6
Viewing angle	Top	CR 10	10	-	-	deg.	Note 7
	Bottom		30	-	-		
	Left		45	-	-		
	Right		45	-	-		
Brightness	Y_L	=0 °	220	250	-	cd/m ²	Note 1,8
Color chromaticity (CIE)	W_x	=0 °	0.25	0.3	0.35		
	W_y		0.3	0.35	0.40		
	R_x		0.52	0.55	0.58		
	R_y		0.31	0.34	0.37		
	G_x		0.27	0.30	0.33		
	G_y		0.55	0.58	0.61		
	B_x		0.13	0.16	0.19		
	B_y		0.13	0.16	0.19		
White Uniformity	w		60%				Note 9
Flicker	F			-35	-30	dB	Note 10,11

Voltage vs Transmittance

Voltage (Unit:Volt)	Normalized Transmittance Value (Unit:%)		Remark
	Typ.	Tolerance	
0	100	-	Note 12
1	97.05	± 5%	
1.55	79.38	± 10%	
1.93	61.07	± 10%	
2.2	41.51	± 10%	
2.6	19.58	± 20%	
4.0	0.98	± 100%	

Note 1. Ambient temperature =25 . And lamp current $I_L=2.8\text{mA rms}$.

Note 2. To be measured in the dark room.

Note 3.To be measured on the center area of panel with a field angle of 1 ° by Topcon luminance meter BM-7, after 10 minutes operation.

Note 4. Definition of response time:

The output signals of photo detector are measured when the input signals are changed from “black” to “white” (falling time) and from “white” to “black” (rising time), respectively. The response time is defined as the time interval between the 10% and 90% of amplitudes. Refer to figure as below.

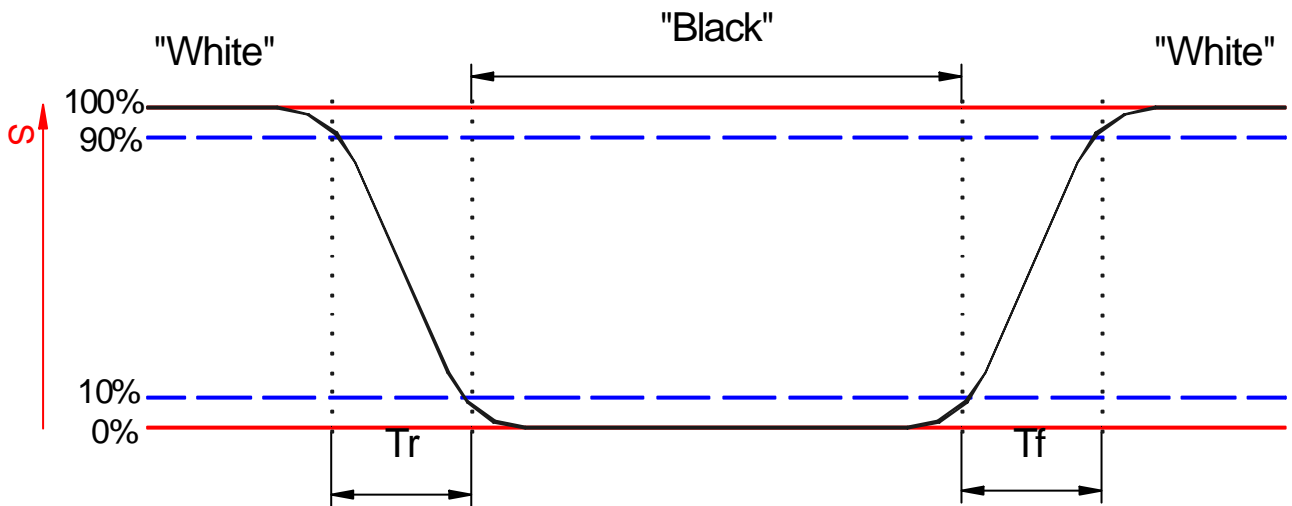

Note 5. Definition of contrast ratio:

Contrast ratio is calculated with the following formula.

$$\text{Contrast ratio (CR)} = \frac{\text{Photo detector output when LCD is at "White" state}}{\text{Photo detector output when LCD is at "Black" state}}$$

Note 6. White $V_i = V_{i50} \mp 1.5V$

Black $V_i = V_{i50} \pm 2.0V$

“ \pm ” Means that the analog input signal swings in phase with COM signal.

“ \mp ” Means that the analog input signal swings out of phase with COM signal.

V_{i50} : The analog input voltage when transmission is 50%

The 100% transmission is defined as the transmission of LCD panel when all the input terminals of module are electrically opened.

Note 7. Definition of viewing angle:

Refer to figure as below.

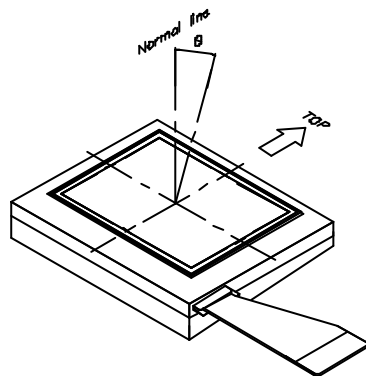

Note 8. Measured at the center area of the panel when all the input terminals of LCD panel are electrically opened.

Note 9. Definition of white uniformity:

White uniformity is defined as the following with nine measurements(A~I).

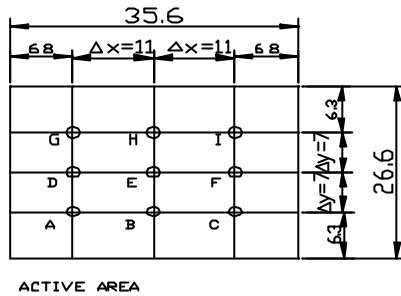

$$w = \frac{\text{Maximum Luminance of nine points(brightness)}}{\text{Minimum Luminance of nine points(brightness)}}$$

Note 10. Measured at the center area of the panel by using the test pattern with grey raster (Transmission rate = 50%) by BM-5A.

$$F = 20 \log \frac{V_{ACnn}(\text{rms})}{V_{\text{mean}}(\text{rms})} \quad (\text{dB})$$

Note 11. The criteria of flicker level will be judged by the limit sample with the mutual agreement of Fujifilm and Unipac.

Note 12. Set the brightness of 0 volt as 100%.

D. Reliability test items(Note 1):

No.	Test items	Conditions	Judgement	Remark
1	High temperature storage	Ta= 80 240Hrs	Display quality	Note 2
2	Low temperature storage	Ta= -25 240Hrs	Display quality	Note 2
3	High temperature operation	Ta= 60 240Hrs	Display quality	Note 2
4	Low temperature operation	Ta= 0 240Hrs	Display quality	Note 2
5	High temperature and high humidity	Ta= 60 . 95% RH 240Hrs	Display quality	Operation (Note 2)
6	Heat shock	-25 ~80 /50 cycle 2Hrs/cycle	Display quality	Non-operation (Note 2)
7	Electrostatic discharge	± 200V,200pF(0), once for each terminal	Display function	Non-operation
		C=150pF,R=330 ± 5 KV,5 times for panel surface	Display function	Non-operation (Note 3)
8	Vibration	Frequency range : 10~55Hz Stoke : 1.5mm Sweep : 10~55Hz~10Hz 2 hours for each direction of X.Y.Z (6 hours for total)	Display quality	Non-operation JIS C7021, A-10 condition A (Note 2)
9	Mechanical shock	100G . 6ms, ± X, ± Y, ± Z 3 times for each direction	Display quality	Non-operation JIS C7021, A-7 condition C (Note 2)
10	Vibration (with carton)	Frequency range:10~55Hz(log) 1G(9.8 m/s ²) 20 minutes for each direction of X,Y,Z(1 hour for total)	Display quality	(Note 2)
11	Drop (with carton)	Height: 60cm 1 corner, 3 edges, 6 surfaces	Display quality	Note 2
12	FPC Flexibility strength	Bending degree: ± 90 ° Total 10 times	Display function	Non-operation
13	FPC Pulling strength	FPC outlet direction Pulling force: 5N	Display function	Non-operation (Note 2)
14	Backlight harness Flexibility strength	Bending degree: ± 90 ° Total 10 times	Display function	Non-operation (Note 2)
15	Backlight harness pulling strength	Backlight harness outlet direction Pulling force: 5N	Display function	Non-operation (Note 2)



Spec. No. : 413-212-091
Version : 1
Page : 13 /28

Ta : Ambient Temperature

Note 1:Evaluation should be tested after storage at room temperature for one hour

Note 2:There should be no change which might affect the practical display function when the display quality test is conducted under normal operating condition

Note 3:Before perform the ESD test, the case shield of LCD module should connect to the ground first.

E. Packing form

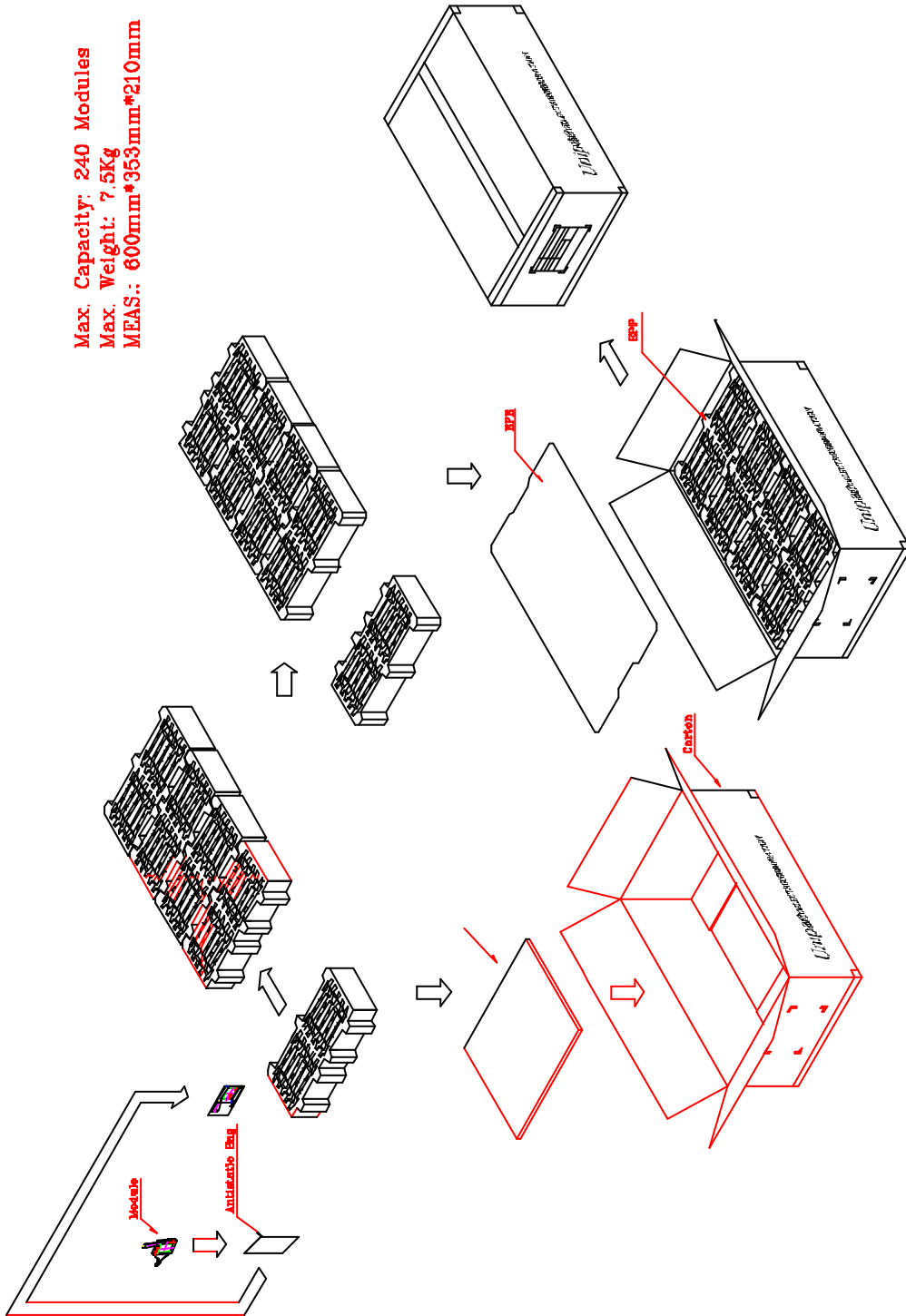

U N I P 2001, C
 A L L P I N G
 C O P Y I N G

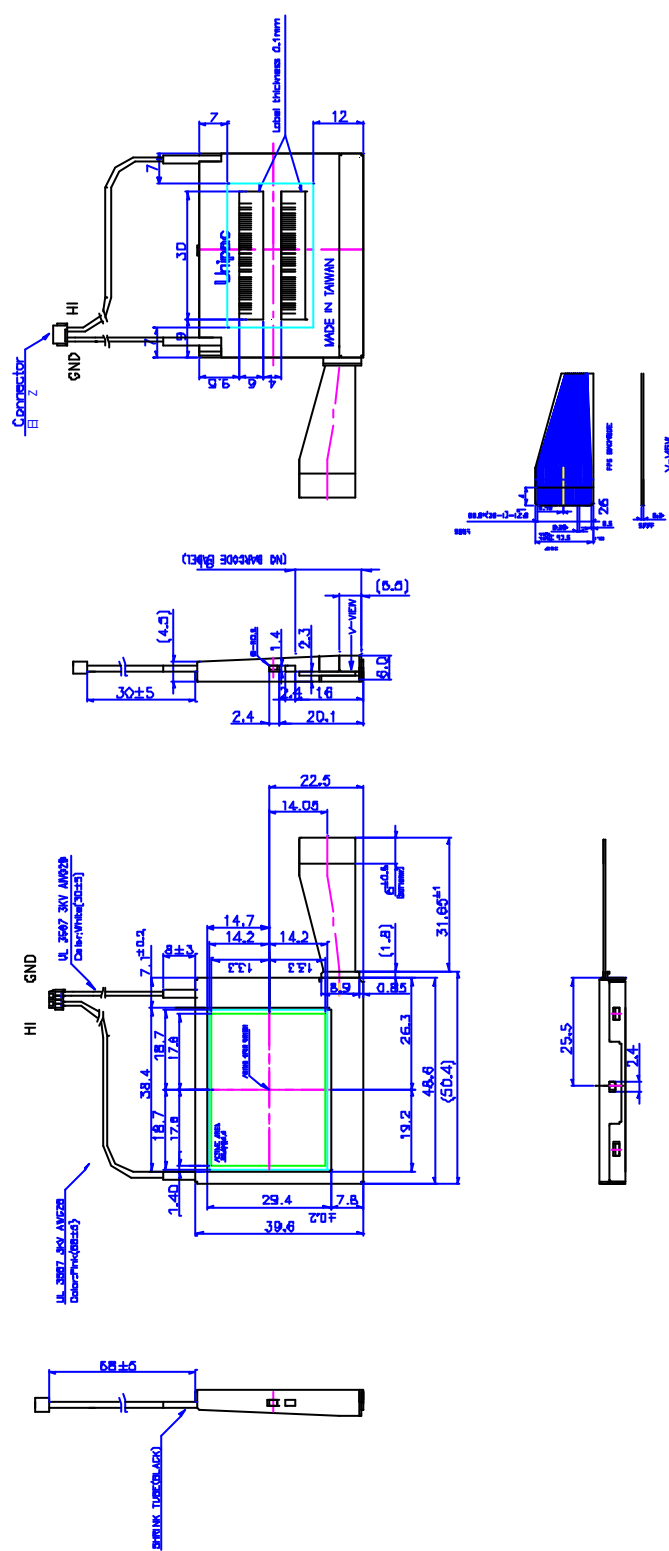

- NOTES:
- 1.General tolerance is ±0.3.
 - 2.The bending radius of FPC should be larger than 0.6.
 - 3.Unit : mm
 - 4.Label : 1) 7mm 2) Label is 30X6 mm

UNIPAC CORP. STRICTLY RESERVE ALL RIGHTS RESERVED. COPIING PROHIBITED.

Fig.1 Outline dimension of TFT-LCD module

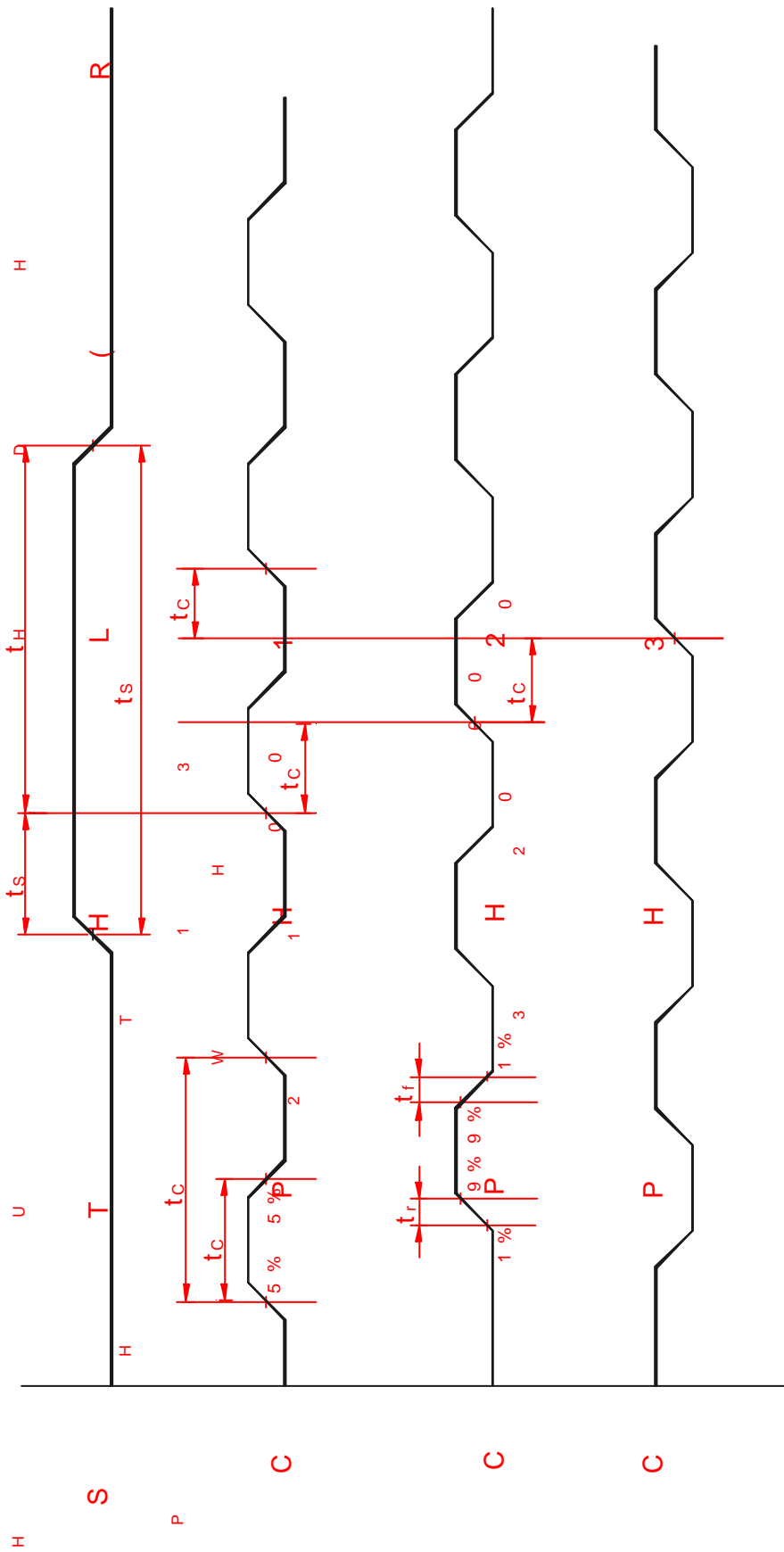

Fig. 2 Sampling clock timing

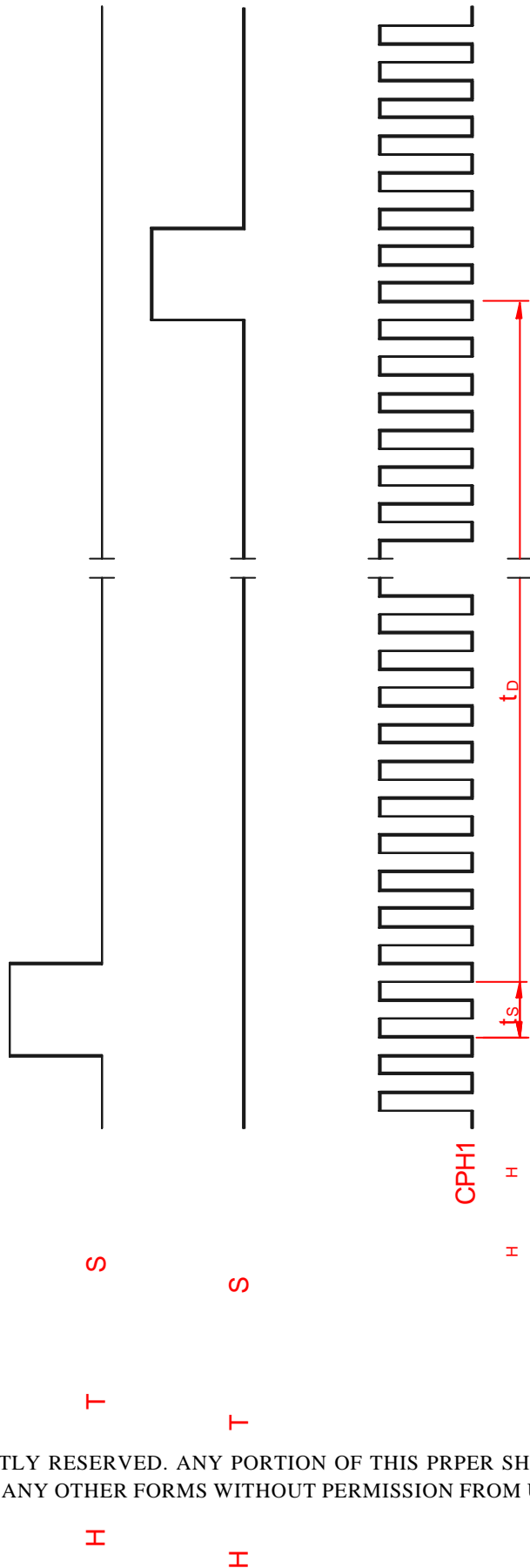

Fig. 3 Horizontal display timing range(Normal scanning mode)

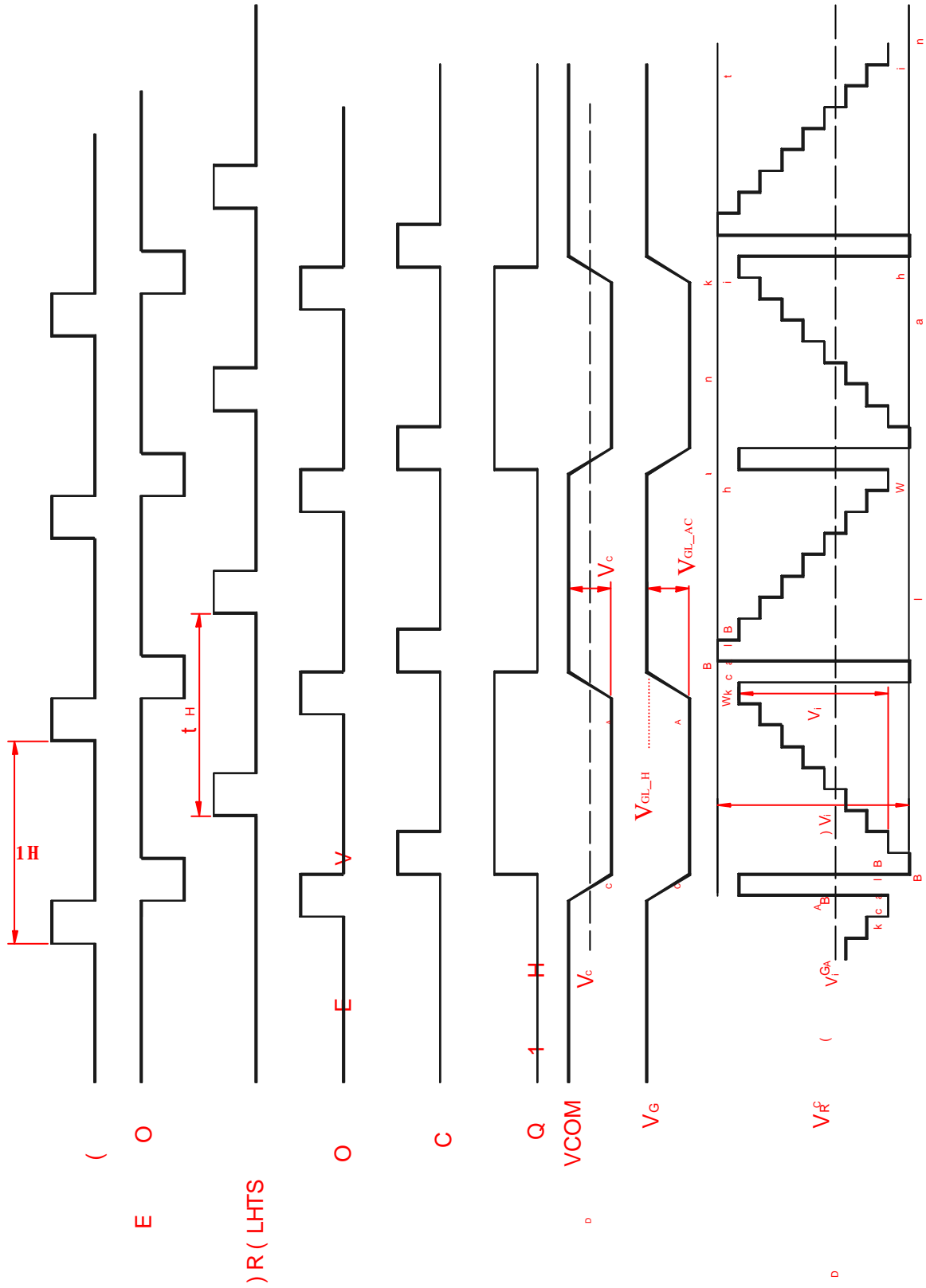

Fig.4-(a) Horizontal timing



Spec. No. : 413-212-091
Version : 1
Page : 19 /28



Spec. No. : 413-212-091
Version : 1
Page : 20 /28

Fig. 4-(b) Detail horizontal timing

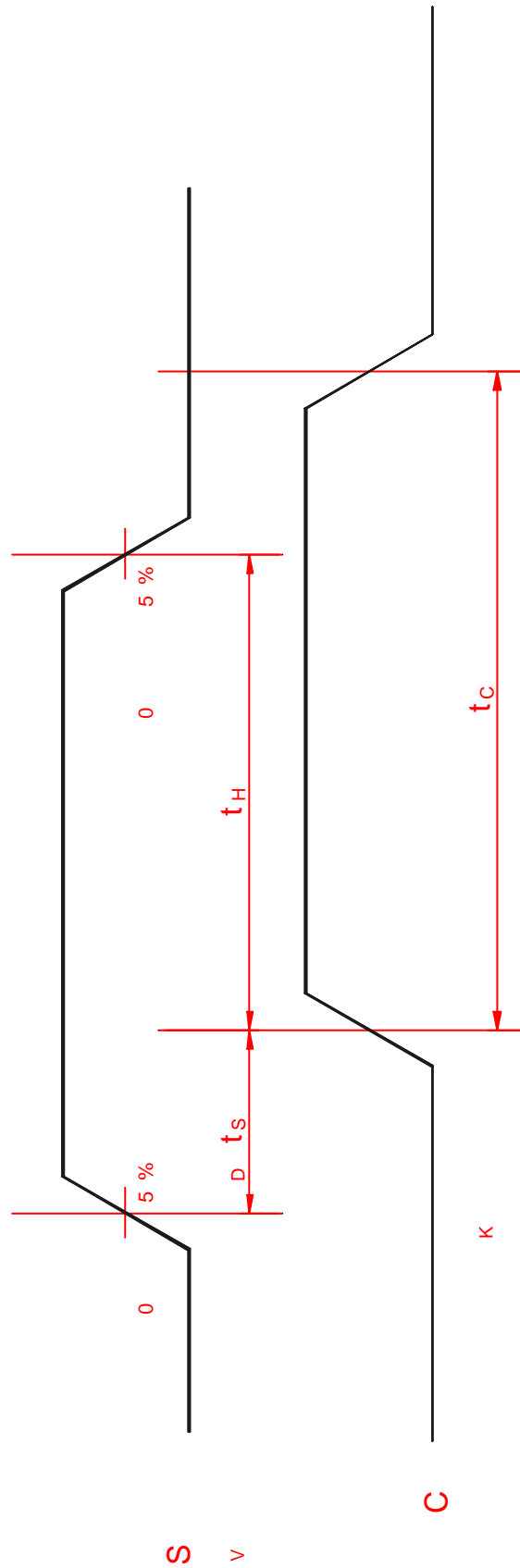

Fig.5 Vertical shift clock timing

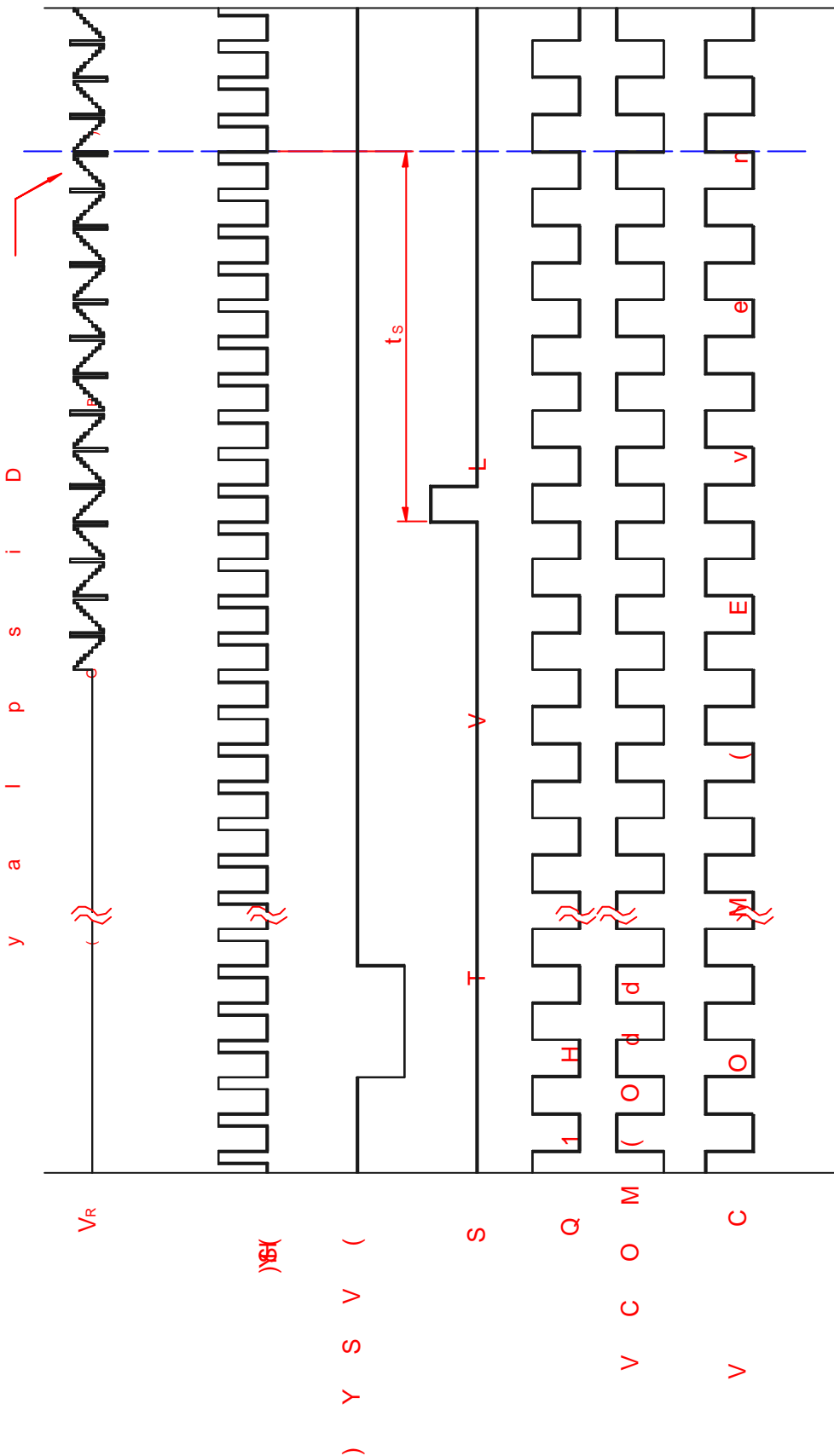

Fig.6-(a) Vertical timing (From up to down)

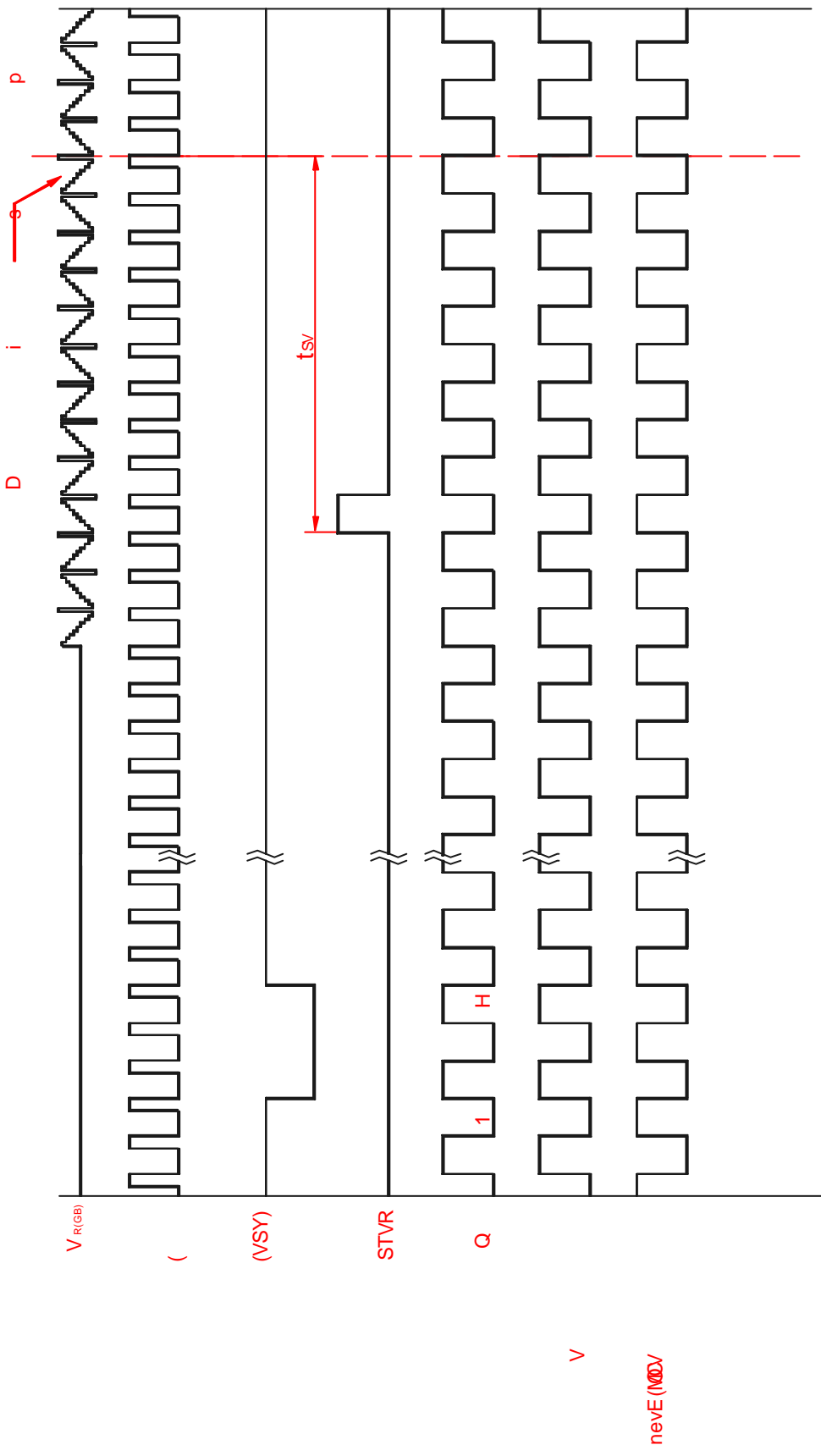

Fig.6-(b) Vertical timing (From down to up)

Incoming Inspection Standard

1.Scope

The incoming inspection standards shall be applied to TFT-LCD Modules (hereinafter called "Modules") that supplied by Unipac Optoelectronics Corporation (hereinafter called "seller").

2.Incoming inspection:

The buyer(customer) shall inspect the modules within twenty calendar days of the delivery date (the "inspection period") at its own cost. The results of the inspection (acceptance or rejection) shall be recorded in writing, and a copy of this writing will be promptly sent to the seller.

The buyer may, under commercially reasonable reject procedures, reject an entire lot in the delivery involved if, within the inspection period,such samples of modules within such lot show an unacceptable number of defects in accordance with this incoming inspection standards, provided however that the buyer must notify the seller in writing of any such rejection promptly, and not later than within three business days of the end of the inspection period.

Should the buyer fail to notify the seller within the inspection period, the buyer's right to reject the modules shall be lapsed and the modules shall be deemed to have been accepted by the buyer.

3.Inspection sampling method:

Unless otherwise agree in writing, the method of incoming inspection shall be based on MIL-STD-105E.

3-1. Lot size: Quantity per shipment lot per model.

3-2. Sampling type: Normal inspection, single sampling.

3-3. Sampling level: Level II.

3-4. Acceptable quality level (AQL):

3-4-1. Major defect: AQL=0.4%.

3-4-2. Minor defect: AQL=1.5%.

4.Inspection instruments:

4-1. A single 20W fluorescent lamp.

4-2. Pattern generator: Philips PM5518 or equivalent model.

4-3. Video board:Unipac video board or equivalent. The output of the signal should comply with the specification provided by Unipac.

4-4. Luminance colorimeter: Topcon BM-7 or equivalent model.

5. Inspection environment conditions:

- 5-1. Room temperature: 25 ± 5 .
- 5-2. Lighting : Fluorescent light (Day-Light Type) display surface illumination to be 500 ~ 1000 Lux.
- 5-3. The viewing line should be perpendicular to the surface of the module.
- 5-4. Inspection distance : 35 ± 5 cm

6. Classification of defects:

Defects are classified as the major defects and minor defects according to the degree of defectiveness defined herein.

6-1. Major defects:

A major defect is a defect that is likely to result in failure, or to reduce the usability of the product for its intended purpose.

6-1-1. Abnormal operation: modules cannot display normally.

6-1-2. Line defect.

6-1-3. There is serious distortion or sharp burr on mechanical housing.

6-1-4. Glass breakage.

6-2. Minor defects:

A minor defect is a defect that is not likely to reduce the usability of the product for its intended purpose.

6-2-1. Dot defect:

A. Inspection pattern: Full white, full black, red, green and blue screens

B. The definition of display area:

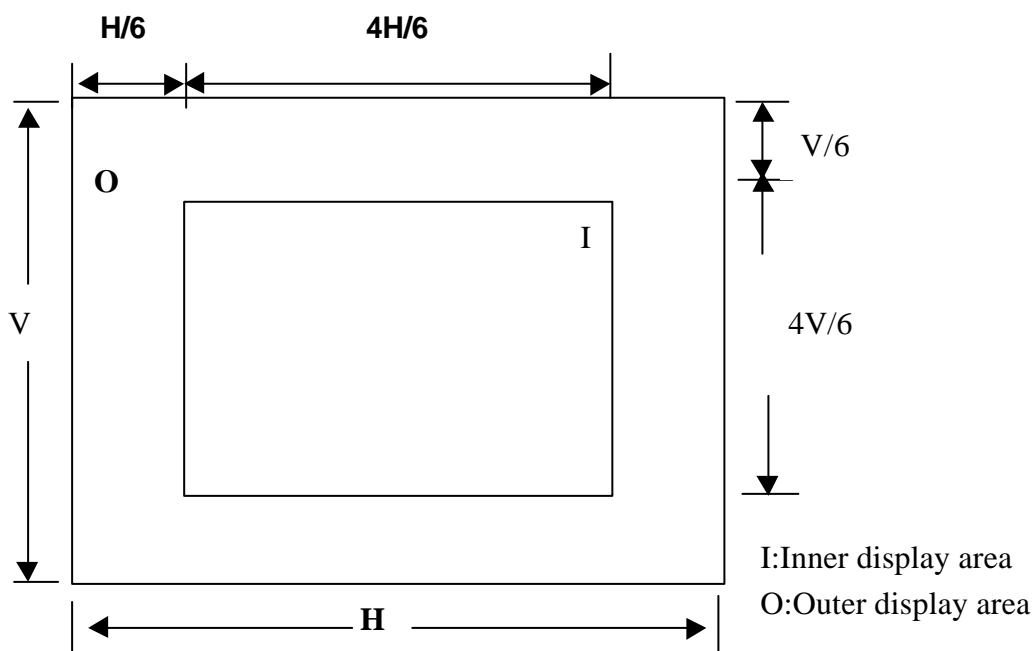

C.Criteria:(acceptable)

Item	Zone		Total
	I	O	
Black dot defect	1	3	4
Bright dot defect (red,green,blue,white)	0	2	2
Total	1	4	4

Note 1.Dot defect is defined as the defective area of the dot is larger than 50% of the dot area by 5% ND filter observation.

2.The distance between the dot defects should be more than 5mm apart.

3.The spec above is OK for now. If there is any problem raised, both sides have to negotiate for solution before to modify the spec.

6-2-2.Scratches,dent and extraneous substances:

A.Inspection conditions:

- a.Luminance : Use a single 20W fluorescent lamp for illumination.
- b.Distance : 35± 5cm

B.Criteria:

Item		Acceptable criteria
Scratch on the polarizer L : Length(mm) W : Width(mm)	L ≤ 0.5	Ignore
	0.5 < L ≤ 5 0.1 ≤ w ≤ 0.5	N 1
	5 < L	None
	0.1 ≤ w ≤ 0.5	None
	W > 0.5	None
Dent on the polarizer D : Average diameter(mm)	D ≤ 0.25	Ignore
	0.25 < D ≤ 0.5	N 1
	0.5 < D	None

Note:1.The extraneous substance is defined as it is appears when the module is power on.

2.The spec of “ scratch on the polarizer” is OK for now. If there is any problem raised, both sides have to negotiate for solution before to modify the spec.

6-2-3.After image:

After displaying the checkerboard pattern for **2 hours at room temperature** then switch to the white pattern, the previous pattern should disappear within 10 seconds.

Note:The spec above is acceptable for now. If there is any problem raised, both sides have to negotiate for solution before to modify the spec.

6-2-4.Following defect to be judged by limit samples when it is necessary.

A.Rubbing mark

B.Mottling (uniformity)

7.Inspection judgement:

7-1.The judgement of the shipped lot(acceptance or rejection) shall follow the sampling plan of MIL-STD-105E,single sampling,normal inspection, level .

7-2. If the number of defects is equal to or less than the applicable acceptance level,the lot shall be accepted.

7-3. If the number of defects is more than the applicable acceptance level,the lot shall be rejected and the buyer should inform the seller of the result of incoming inspection in writing.