

SILICON P-N-P HIGH-VOLTAGE TRANSISTORS

Planar epitaxial transistors in TO-39 metal envelopes, intended as general purpose amplifiers and switching devices in industrial and telephone applications.

QUICK REFERENCE DATA

		BFT44	BFT45	
Collector-base voltage (open emitter)	$-V_{CBO}$	max. 300	250	V
Collector-emitter voltage (open base)	$-V_{CEO}$	max. 300	250	V
Collector current (d.c.)	$-I_C$	max. 0,5		A
Total power dissipation up to $T_{case} = 50\text{ }^\circ\text{C}$	P_{tot}	max. 5,0		W
Junction temperature	T_j	max. 200		$^\circ\text{C}$
D.C. current gain	h_{FE}	50 to 150		
Transition frequency at $f = 35\text{ MHz}$	f_T	typ. 70		MHz
$-I_C = 10\text{ mA}; -V_{CE} = 10\text{ V}$				
$-I_C = 15\text{ mA}; -V_{CE} = 10\text{ V}$				

MECHANICAL DATA

Dimensions in mm

Fig. 1 TO-39.

Collector connected to case.

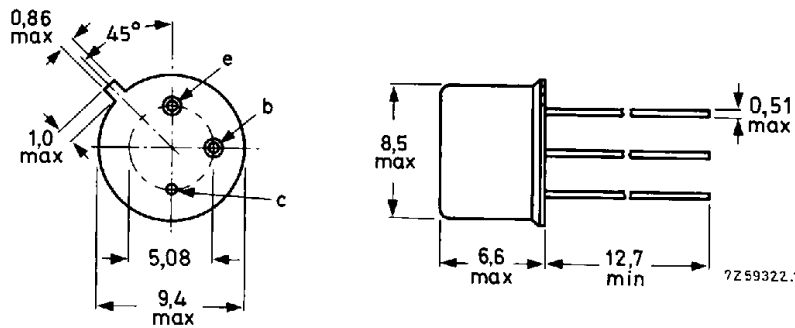

Maximum lead diameter is guaranteed only for 12,7 mm.

BFT44
BFT45

RATINGS

Limiting values in accordance with the Absolute Maximum System (IEC 134)

			BFT44	BFT45	
Collector-base voltage (open emitter)	$-V_{CBO}$	max.	300	250	V
Collector-emitter voltage (open base)	$-V_{CEO}$	max.	300	250	V
Emitter-base voltage (open collector)	$-V_{EBO}$	max.	5	5	V
Collector current (d.c.)	$-I_C$	max.		0,5	A
Total power dissipation up to $T_{case} = 50\text{ }^\circ\text{C}$	P_{tot}	max.		5,0	W

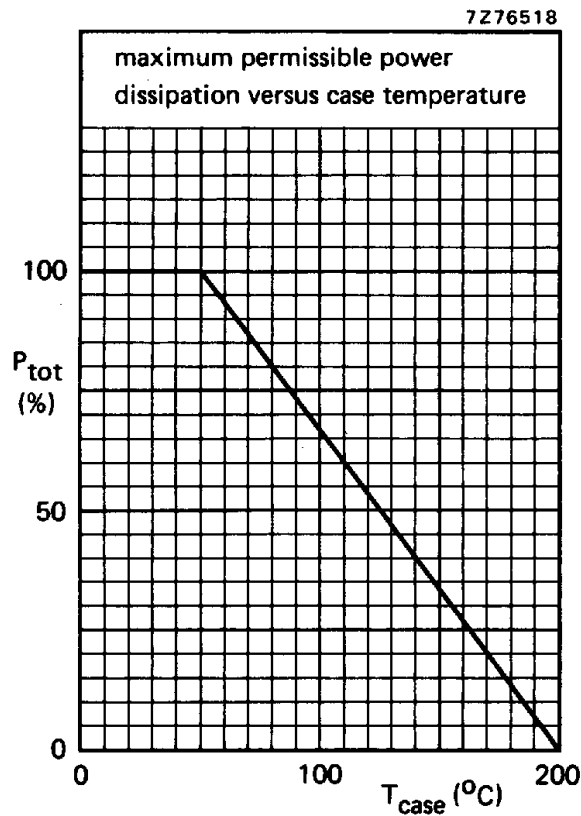

Fig. 2.

Storage temperature range	T_{stg}	=	-65 to + 150	$^\circ\text{C}$
Junction temperature	T_j	max.	200	$^\circ\text{C}$

THERMAL RESISTANCE

From junction to ambient in free air	R_{thj-a}	=	200	K/W
From junction to case	R_{thj-c}	=	30	K/W

CHARACTERISTICS

$T_j = 25\text{ }^\circ\text{C}$ unless otherwise specified

Collector cut-off current
 $I_E = 0; -V_{CB} = 200\text{ V}$

Emitter cut-off current
 $I_C = 0; -V_{EB} = 3\text{ V}$

Collector-emitter sustaining voltage
 $-I_C = 10\text{ mA}; I_B = 0; L = 25\text{ mH}$

$$-I_{CBO} < 5\text{ }\mu\text{A}$$

$$-I_{EBO} < 5\text{ }\mu\text{A}$$

	BFT44	BFT45
$-V_{CEO\text{sust}}$	> 300	250 V^*

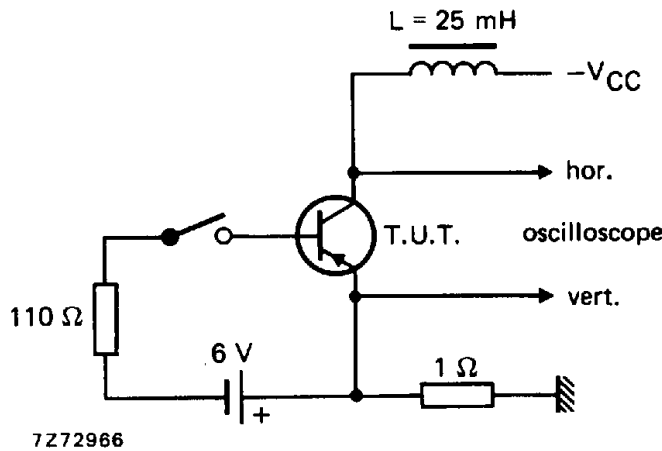

Fig. 3 Test circuit for $V_{CEO\text{sust}}$.

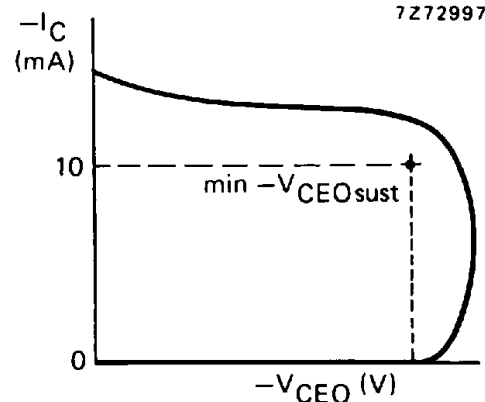

Fig. 4 Oscilloscope display for $V_{CEO\text{sust}}$.

Saturation voltages

$-I_C = 10\text{ mA}; -I_B = 1\text{ mA}$

$-I_C = 100\text{ mA}; -I_B = 10\text{ mA}$

$-I_C = 500\text{ mA}; -I_B = 100\text{ mA}$

BFT44
BFT45

$$-V_{CE\text{sat}} < 0,5\text{ V}$$

$$-V_{BE\text{sat}} < 0,8\text{ V}$$

$$-V_{CE\text{sat}} < 1,4\text{ V}$$

$$-V_{BE\text{sat}} < 0,9\text{ V}$$

$$-V_{CE\text{sat}} < 5,0\text{ V}^{**}$$

$$-V_{CE\text{sat}} < 3,0\text{ V}^{**}$$

$$-V_{BE\text{sat}} < 1,2\text{ V}^{**}$$

D.C. current gain

$-I_C = 1\text{ mA}; -V_{CE} = 10\text{ V}$

$-I_C = 10\text{ mA}; -V_{CE} = 10\text{ V}$

$-I_C = 100\text{ mA}; -V_{CE} = 10\text{ V}$

$$h_{FE} > 30$$

$$h_{FE} \quad 50\text{ to }150$$

$$h_{FE} > 50 \quad **$$

Collector capacitance at $f = 1\text{ MHz}$

$I_E = I_e = 0; -V_{CB} = 20\text{ V}$

$$C_c < 15\text{ pF}$$

* $-V_{CC} = 0\text{ to }50\text{ V}; f = 400\text{ Hz}; \delta = 0,5$ (see also test circuit).

** Measured under pulse conditions: $t_p = 300\text{ }\mu\text{s}; \delta \leq 0,02$.

BFT44
BFT45

CHARACTERISTICS (continued)

$T_j = 25\text{ }^\circ\text{C}$

Transition frequency at $f = 35\text{ MHz}$

$-I_C = 15\text{ mA}; -V_{CE} = 10\text{ V}$

f_T typ. 70 MHz

Switching times

$-I_{Con} = 50\text{ mA}; -I_{Bon} = I_{Boff} = 5\text{ mA}$ (test circuit 1)

t_{on} typ. 125 ns

t_{off} typ. 850 ns

$-I_{Con} = 500\text{ mA}; -I_{Bon} = I_{Boff} = 100\text{ mA}$ (test circuit 2)

t_{on} typ. 125 ns

t_{off} typ. 125 ns

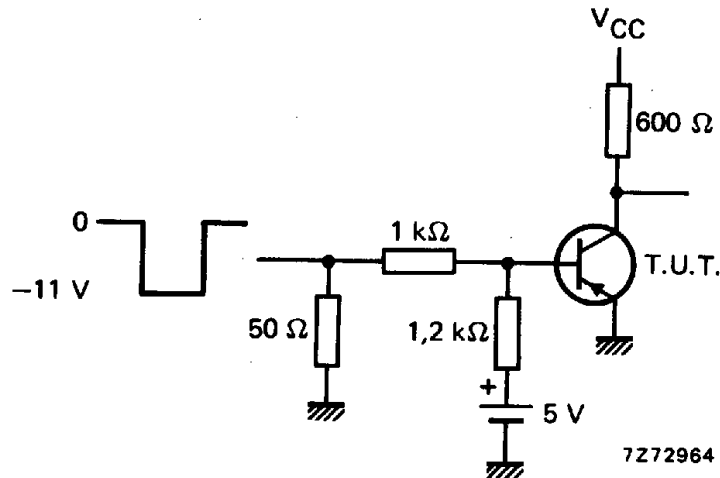

Fig. 5 Test circuit 1.

$V_{CC} = -31\text{ V}$

$t_p = 10\text{ }\mu\text{s}$

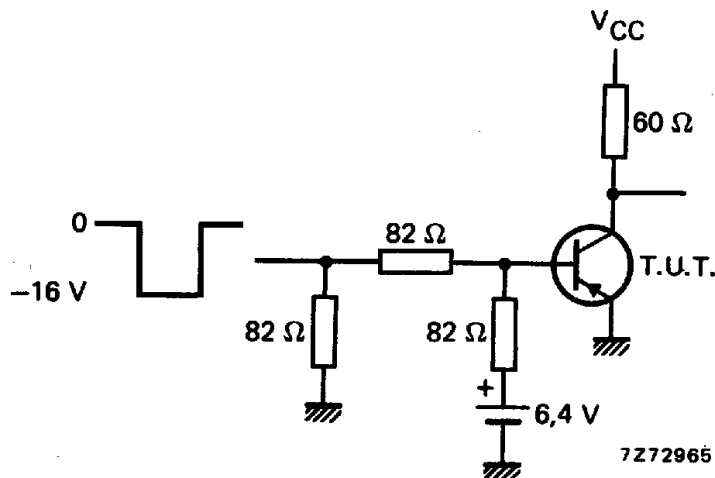

Fig. 6 Test circuit 2.

$V_{CC} = -31\text{ V}$

$t_p = 10\text{ }\mu\text{s}$

Silicon p-n-p high-voltage transistors

BFT44
BFT45

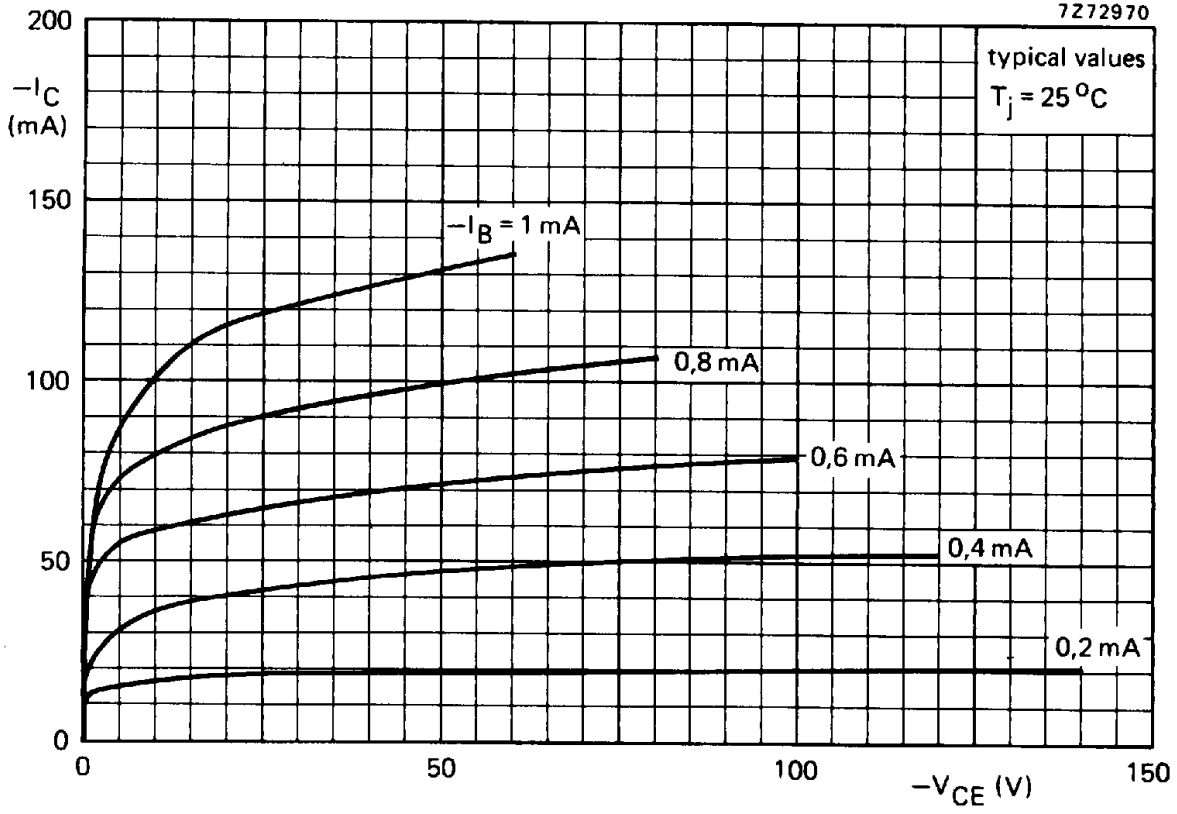

Fig. 7.

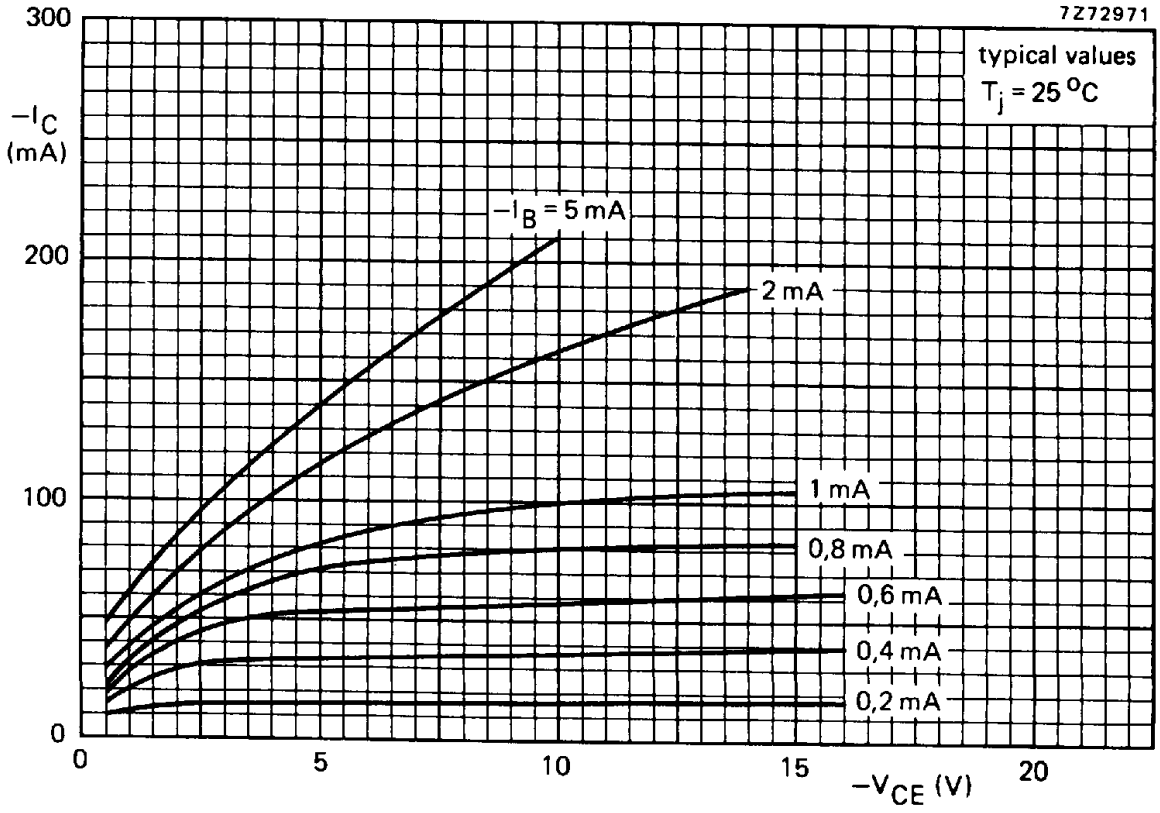

Fig. 8.

BFT44
BFT45

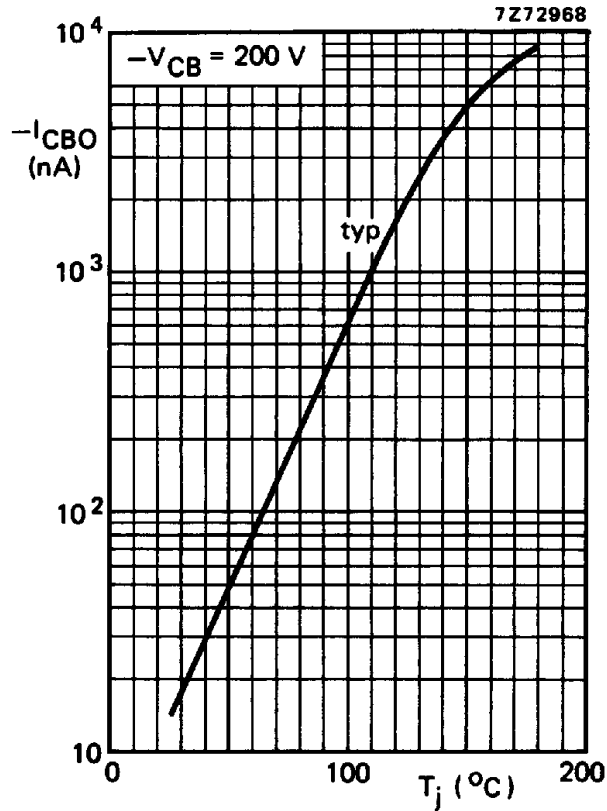

Fig. 9.

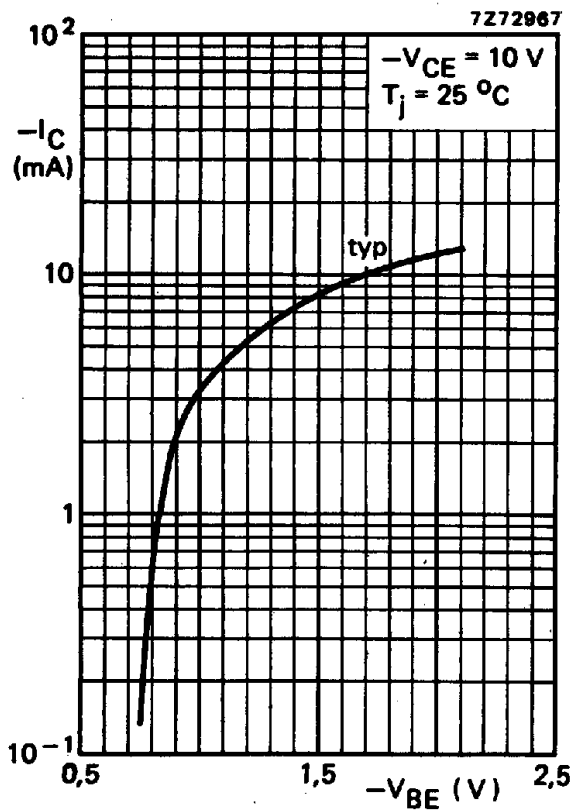

Fig. 10.

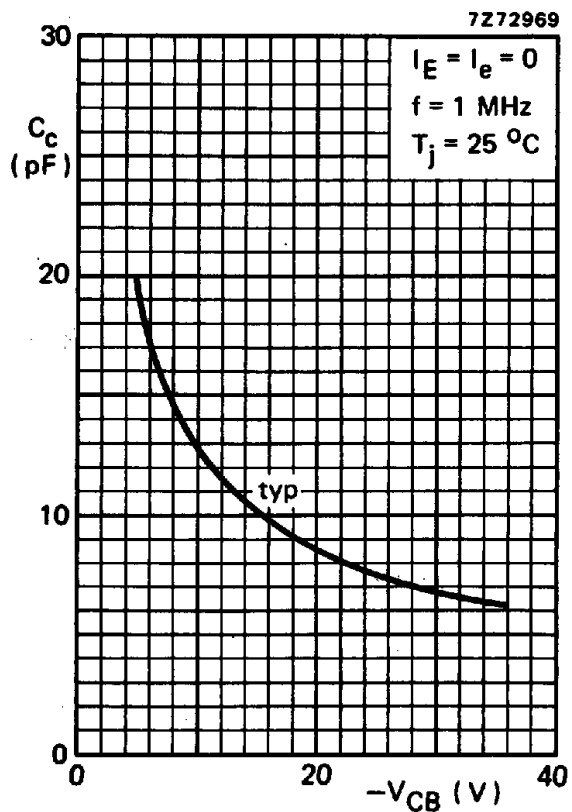

Fig. 11.

Silicon p-n-p high-voltage transistors

BFT44
BFT45

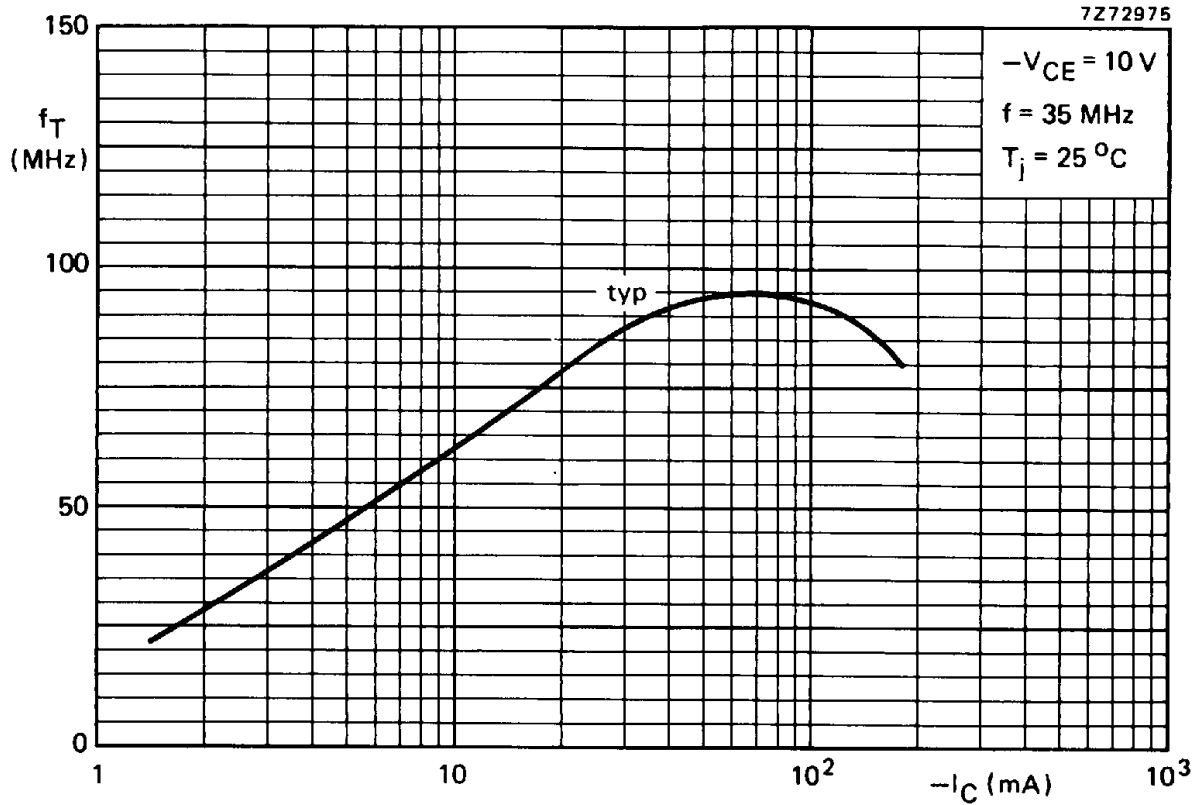

Fig. 12.

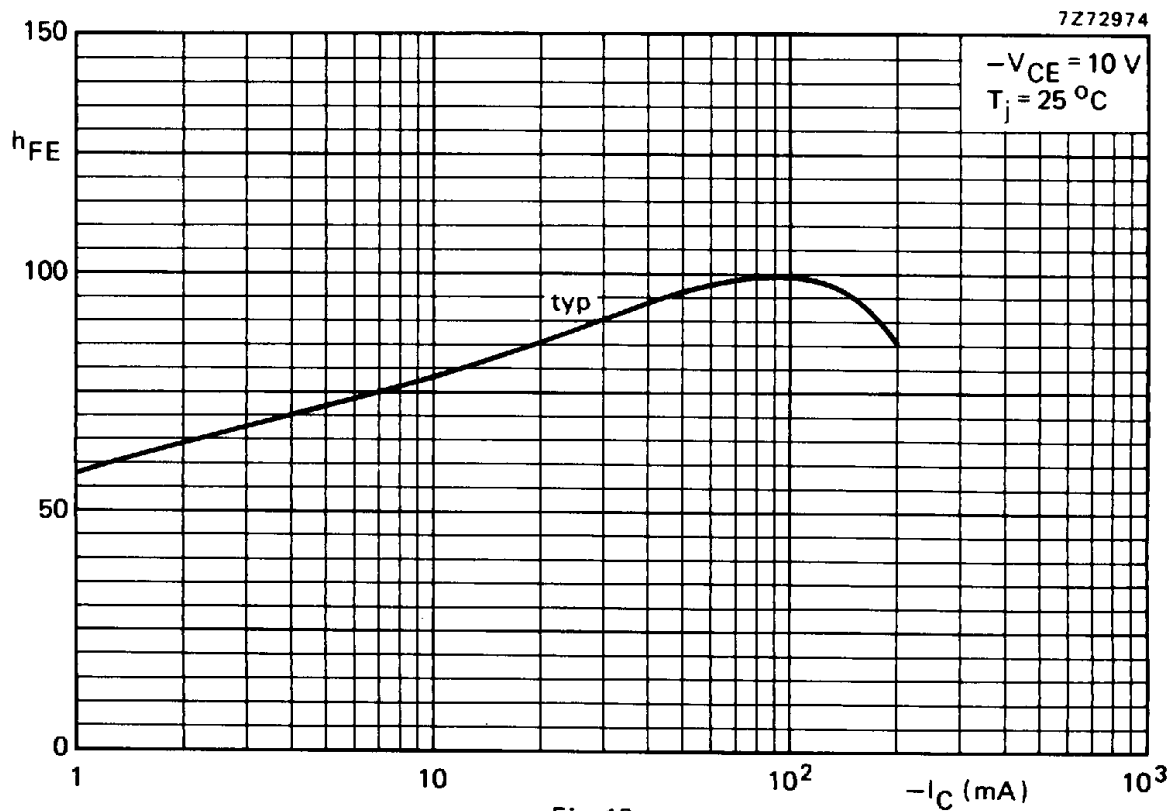

Fig. 13.

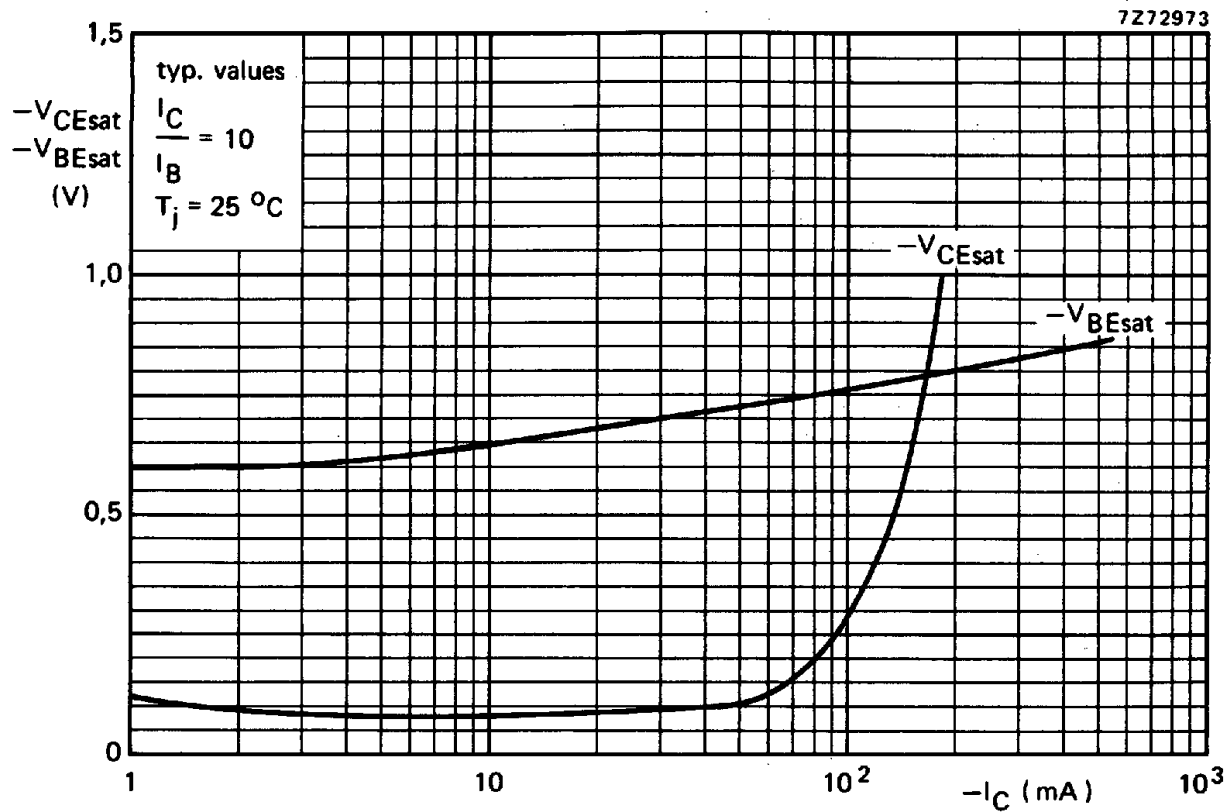

Fig. 14.

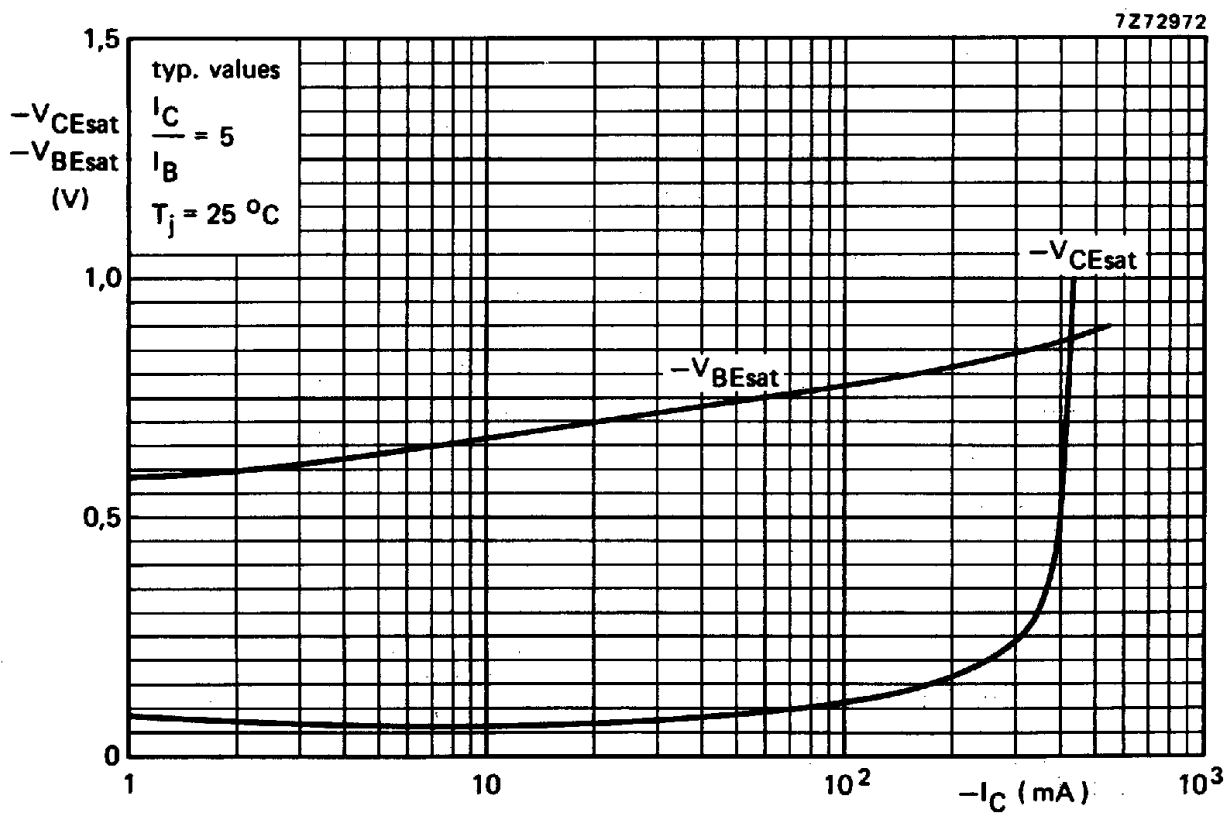

Fig. 15.