

2595

8-CHANNEL SATURATED SINK DRIVER

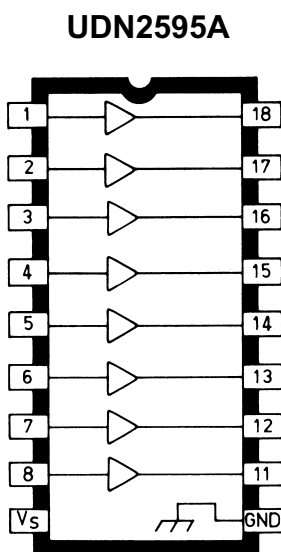

Dwg. No. A-11,407

ABSOLUTE MAXIMUM RATINGS at 25°C Free-Air Temperature for any one driver (unless otherwise noted)

Output Voltage, V_{CE}	20 V
Supply Voltage, V_S	20 V
Input Voltage, V_{IN}	20 V
Output Current, I_C	200 mA
Ground Terminal Current, I_{GND} ...	1.6 A
Package Power Dissipation, P_D	See Graph
Operating Temperature Range, T_A	-20°C to +85°C
Storage Temperature Range, T_S	-55°C to +150°C

Developed for use with low-voltage LED and incandescent displays requiring low output saturation voltage, the UDN2595A and A2595SLW meet many interface needs, including those exceeding the capabilities of standard logic buffers. The eight non-Darlington outputs of each driver can continuously and simultaneously sink load currents of 100 mA at ambient temperatures of up to +75°C.

The eight-channel driver's active-low inputs can be driven directly from TTL, Schottky TTL, DTL, 5 to 16 V CMOS, and NMOS logic. All input connections are on one side of the package, output connections on the other, for simplified printed wiring board layouts.

These drivers are packaged in plastic DIPs (suffix A) or surface-mountable wide-body SOICs (suffix LW), and are rated for operation over the temperature range of -20°C to +85°C. The A2595SLW is also available for operation to -40°C. To order, change the suffix from 'SLW' to 'ELW'.

FEATURES

- Non-Inverting Function
(Input Low = Output ON)
- 200 mA Current Rating
- 100 mA Continuous and Simultaneous
(All outputs) to +85°C
- Low Saturation Voltage
- TTL, CMOS, NMOS Compatible
- Efficient Input/Output Pin Format
- DIP or SOIC Packaging

Always order by complete part number:

Part Number	Package
UDN2595A	18-Pin DIP
A2595SLW	20-Lead Wide-Body SOIC



2595 8-CHANNEL SATURATED SINK DRIVER

FUNCTIONAL BLOCK DIAGRAM

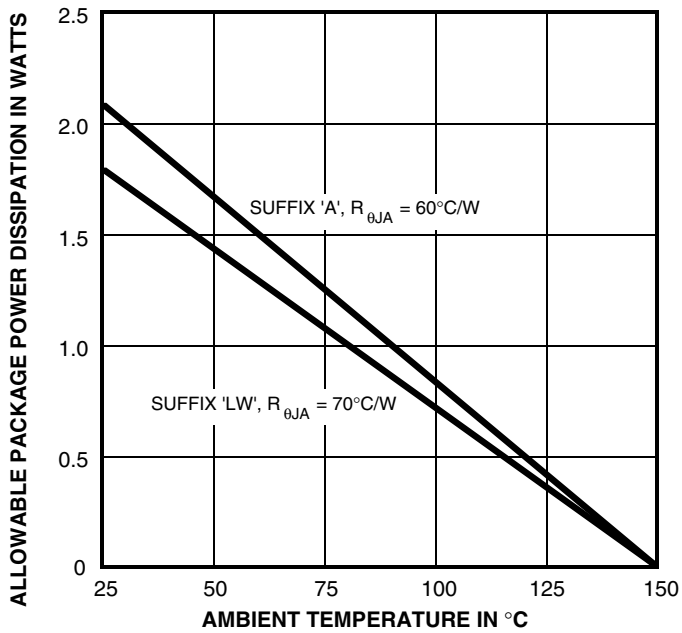
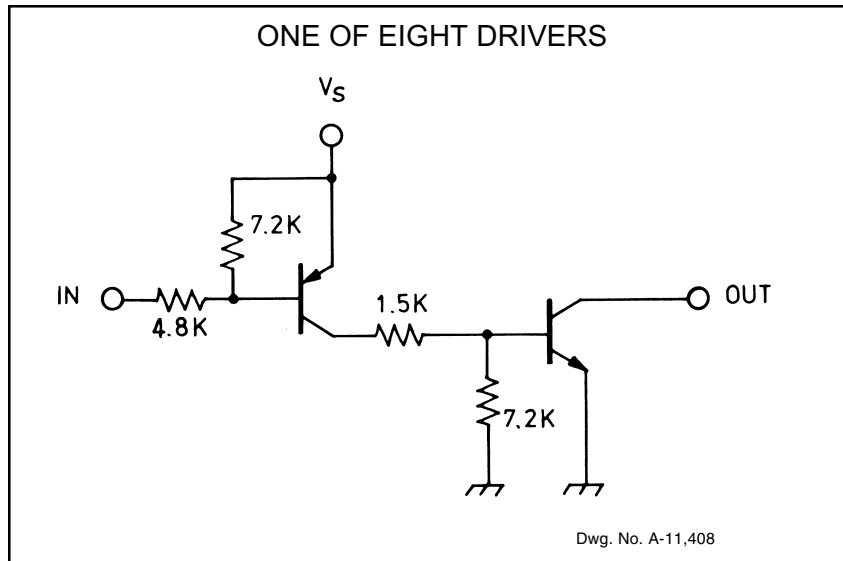

Dwg. GS-009-1

A2595SLW

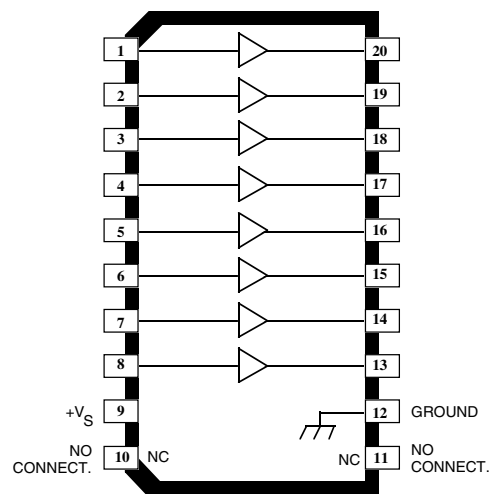

Dwg. PP-064-1



115 Northeast Cutoff, Box 15036
Worcester, Massachusetts 01615-0036 (508) 853-5000
Copyright © 1981, 2000 Allegro MicroSystems, Inc.

2595
8-CHANNEL
SATURATED SINK DRIVER

ELECTRICAL CHARACTERISTICS at $T_A = +25^\circ\text{C}$, $V_S = 5.0\text{ V}$ (unless otherwise noted).

Characteristic	Symbol	Test Conditions	Limits		
			Min.	Max.	Units
Output Leakage Current	I_{CEX}	$V_{IN} \geq 4.5\text{ V}$, $V_{OUT} = 20\text{ V}$, $T_A = 25^\circ\text{C}$	—	50	μA
		$V_{IN} \geq 4.6\text{ V}$, $V_{OUT} = 20\text{ V}$, $T_A = 70^\circ\text{C}$	—	100	μA
Output Saturation Voltage	$V_{CE(SAT)}$	$V_{IN} = 0.4\text{ V}$, $I_{OUT} = 50\text{ mA}$	—	0.5	V
		$V_{IN} = 0.4\text{ V}$, $I_{OUT} = 100\text{ mA}$	—	0.6	V
Input Current	$I_{IN(ON)}$	$V_{IN} = 0.4\text{ V}$, $I_{OUT} = 100\text{ mA}$	—	-1.6	mA
		$V_{IN} = 0.4\text{ V}$, $I_{OUT} = 100\text{ mA}$, $V_S = 15\text{ V}$	—	-5.0	mA
Input Voltage	$V_{IN(ON)}$	$I_{OUT} = 100\text{ mA}$, $V_{OUT} \leq 0.6\text{ V}$	—	0.4	V
	$V_{IN(OFF)}$	$I_{OUT} = 100\text{ }\mu\text{A}$, $T_A = 70^\circ\text{C}$	4.6	—	V
Input Capacitance	C_{IN}		—	25	pF
Supply Current	I_S	$V_{IN} = 0.4\text{ V}$, $I_{OUT} = 100\text{ mA}$	—	6.0	mA
		$V_{IN} = 0.4\text{ V}$, $I_{OUT} = 100\text{ mA}$, $V_S = 15\text{ V}$	—	20	mA

- NOTES: 1. Negative current is defined as coming out of the specified device pin.
 2. The $V_{IN(ON)}$ voltage limit guarantees a minimum output sink current per the specified conditions.
 3. I_S is measured with any one of eight drivers turned ON.

2595 8-CHANNEL SATURATED SINK DRIVER

UDN2595A

Dimensions in Inches
(controlling dimensions)

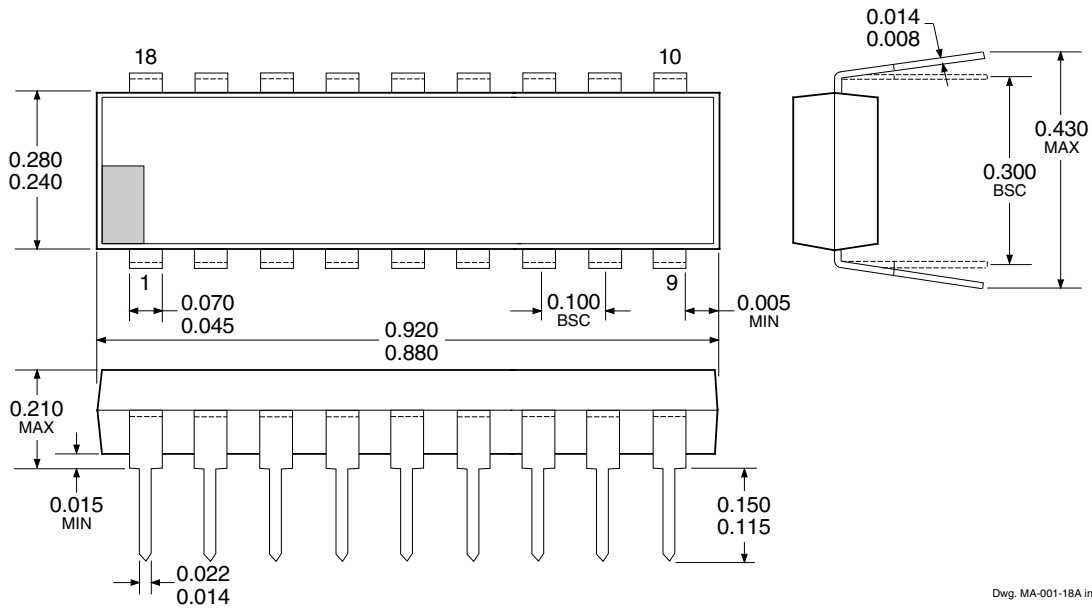

Dwg. MA-001-18A in

Dimensions in Millimeters
(for reference only)

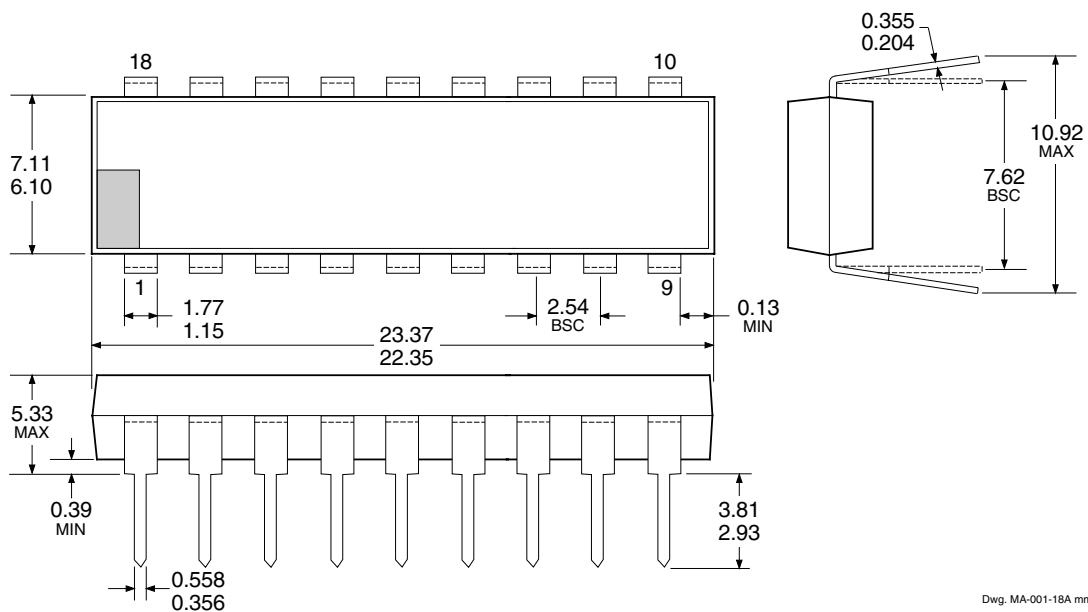

Dwg. MA-001-18A mm

- NOTES:
1. Exact body and lead configuration at vendor's option within limits shown.
 2. Lead spacing tolerance is non-cumulative.
 3. Lead thickness is measured at seating plane or below.



115 Northeast Cutoff, Box 15036
Worcester, Massachusetts 01615-0036 (508) 853-5000

2595 8-CHANNEL SATURATED SINK DRIVER

A2595SLW

Dimensions in Inches
(for reference only)

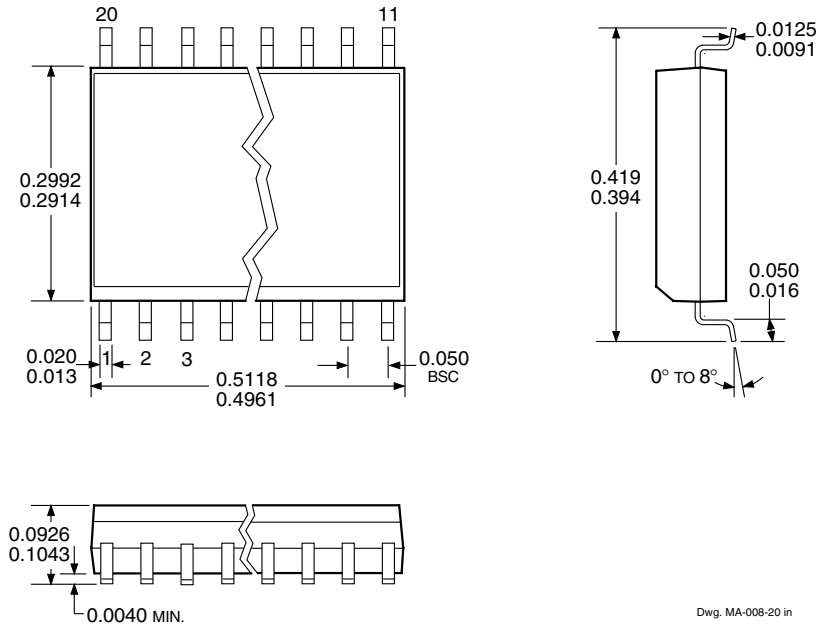

Dimensions in Millimeters
(controlling dimensions)

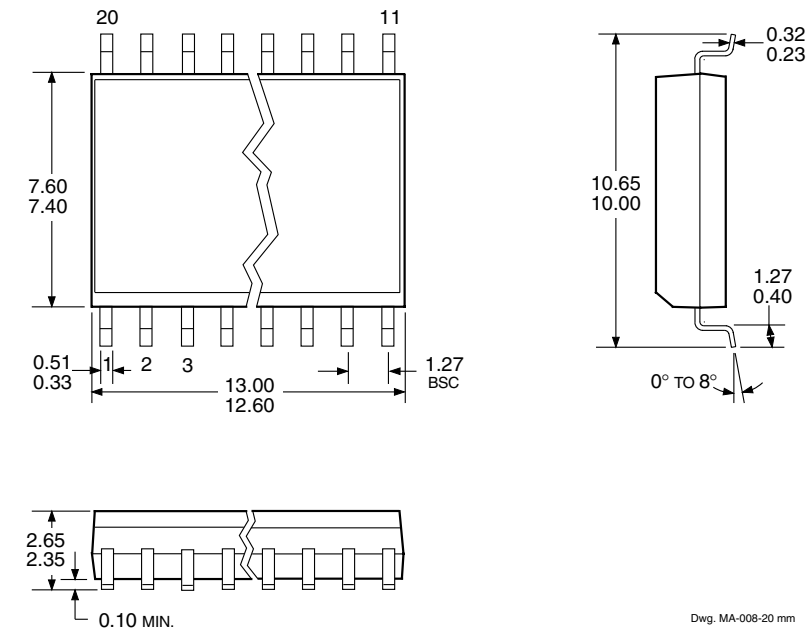

- NOTES: 1. Exact body and lead configuration at vendor's option within limits shown.
2. Lead spacing tolerance is non-cumulative.

2595
8-CHANNEL
SATURATED SINK DRIVER

The products described here are manufactured under one or more U.S. patents or U.S. patents pending.

Allegro MicroSystems, Inc. reserves the right to make, from time to time, such departures from the detail specifications as may be required to permit improvements in the performance, reliability, or manufacturability of its products. Before placing an order, the user is cautioned to verify that the information being relied upon is current.

Allegro products are not authorized for use as critical components in life-support devices or systems without express written approval.

The information included herein is believed to be accurate and reliable. However, Allegro MicroSystems, Inc. assumes no responsibility for its use; nor for any infringement of patents or other rights of third parties which may result from its use.



115 Northeast Cutoff, Box 15036
Worcester, Massachusetts 01615-0036 (508) 853-5000

2595
8-CHANNEL
SATURATED SINK DRIVER

This page is intentionally left blank

2595
8-CHANNEL
SATURATED SINK DRIVER

POWER SINK DRIVERS

IN ORDER OF 1) OUTPUT CURRENT, 2) OUTPUT VOLTAGE, 3) NUMBER OF DRIVERS

Output Ratings *			Features					Part Number [†]
mA	V	#	Serial Input	Latched Drivers	Diode Clamp	Outputs	Internal Protection	
75	17	8	X	X	–	constant current	–	6275
	17	16	X	X	–	constant current	–	6276
100	20	8	–	–	–	saturated	–	2595
	30	32	X	X	–	–	–	5833
	40	32	X	X	–	saturated	–	5832
	50	8	addressable decoder/driver		–	DMOS	–	6B259
	50	8	–	X	–	DMOS	–	6B273
	50	8	X	X	–	DMOS	–	6B595
250	50	8	addressable decoder/driver		–	DMOS	–	6259
	50	8	–	X	–	DMOS	–	6273
	50	8	X	X	–	DMOS	–	6595
	135	7	–	–	X	–	–	7003
300	45	1	–	Hall sensor/driver	X	–	X	5140
	50	7	–	–	X	–	–	2003
	50	8	–	–	X	–	–	2803
	50	8	–	–	X	saturated	–	2596
	60	4	–	–	X	saturated	X	2557
	95	7	–	–	X	–	–	2023
	95	8	–	–	X	–	–	2823
350	50	4	–	X	X	–	–	5800
	50	7	–	–	X	–	–	2004
	50	8	–	–	X	–	–	2804
	50	8	–	X	X	–	–	5801
	50	8	X	X	–	–	–	5821
	50	8	X	X	X	–	–	5841
	50	8	addressable decoder/driver		–	DMOS	–	6A259
	50	8	X	X	–	DMOS	–	6A595
	80	8	X	X	–	–	–	5822
	80	8	X	X	X	–	–	5842
	95	7	–	–	X	–	–	2024
	95	8	–	–	X	–	–	2824
	450	30	28	dual 4- to 14-line decoder/driver		–	–	–
600	60	4	–	–	–	saturated	X	2547
	60	4	–	–	X	saturated	X	2549
700	60	4	–	–	X	saturated	X	2543 and 2559
750	50	8	–	–	X	saturated	–	2597
900	14	2	–	Hall sensor/driver	X	saturated	X	3625
	26	2	–	Hall sensor/driver	X	saturated	X	3626
1000	46	4	stepper motor controller/driver		–	MOS	–	7024 and 7029
1200	46	4	microstepping controller/driver		–	MOS	–	7042
1250	50	4	stepper motor translator/driver		–	–	X	5804
	50	4	–	–	X	–	–	2064 and 2068
1500	80	4	–	–	X	–	–	2065 and 2069
1800	50	4	–	–	X	–	–	2544
	50	4	–	–	X	–	–	2540
3000	46	4	stepper motor controller/driver		–	MOS	–	7026
	46	4	microstepping controller/driver		–	MOS	–	7044
4000	50	4	–	–	X	–	–	2878
	80	4	–	–	X	–	–	2879

* Current is maximum specified test condition, voltage is maximum rating. See specification for sustaining voltage limits or over-current protection voltage limits.

† Complete part number includes additional characters to indicate operating temperature range and package style.



115 Northeast Cutoff, Box 15036
Worcester, Massachusetts 01615-0036 (508) 853-5000