

L200-TPP-180D

Pink

5mm, Flanged Cylindrical, 8.6mm Height
180° viewing angle

DWG BY:
LL / GP
02-14-07

CHK BY:
PL
02-14-07

QA:
—
—-—-—

MFG:
—
—-—-—

REVISION LTR: -
02-14-07

| | | | | | |
|----------|---------------|---------|----------|------|--------|
| Part No. | L200-TPP-180D | DWG NO. | DSDC0537 | Page | 1 of 4 |
|----------|---------------|---------|----------|------|--------|

Features:

- ? High intensity
- ? 5mm diameter package
- ? Tinned leads
- ? Pb-free

Package Dimensions:

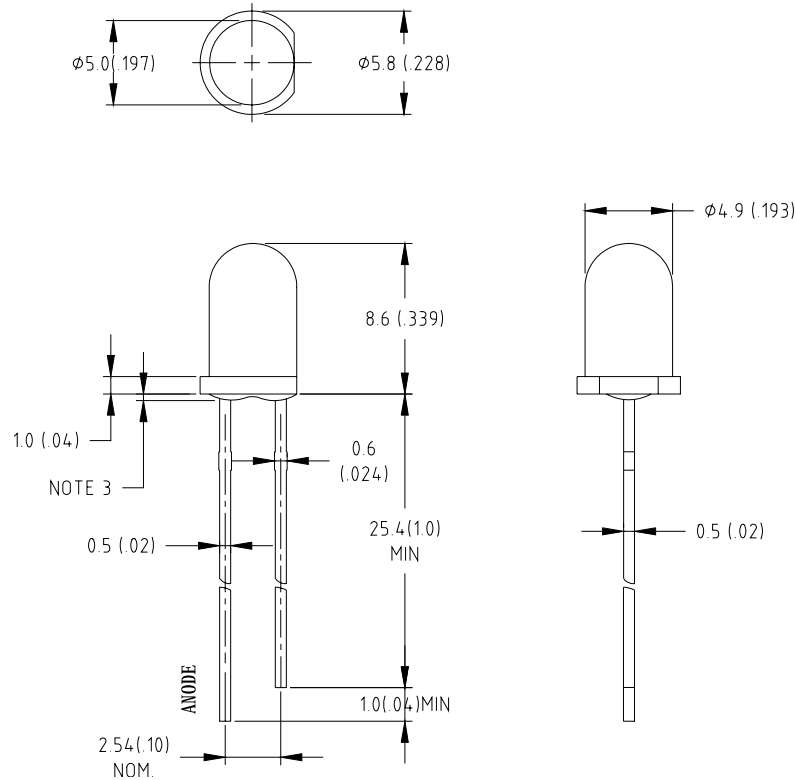

| Part No. | Chip Material | Lens Color | Emission Color |
|---------------|---------------|---------------|----------------|
| L200-TPP-180D | InGaN | Pink Diffused | Pink |

Notes:

1. All dimensions are in millimeters (inches).
2. Tolerance is ± 0.25 mm (.010") unless otherwise noted.
3. Protruded resin under flange is 1.0mm (.04") max.
4. Lead spacing is measured where the leads emerge from the package.
5. Specifications are subject to change without notice.
6. Precautions for ESD:
 Static electricity and surge can damages the LED. It is recommended to use a wrist band or anti-electrostatic glove when handling the LED. All devices, equipment and machinery must be properly grounded.

Absolute Maximum Ratings at Ta=25°C

| Parameter | MAX. | Unit |
|---|---------------------|-------|
| Power Dissipation | 80 | mW |
| Peak Forward Current (1/10 Duty Cycle, 0.1ms Pulse Width) | 100 | mA |
| Continuous Forward Current | 20 | mA |
| Derating Linear From 50°C | 0.4 | mA/°C |
| Reverse Voltage | 5 | V |
| Electrostatic Discharge (ESD) | 150 | V |
| Operating Temperature Range | -30°C to +80°C | |
| Storage Temperature Range | -40°C to +100°C | |
| Lead Soldering Temperature [4mm(.157") From Body] | 260°C for 5 Seconds | |

Electrical Optical Characteristics at Ta=25°C

| Parameter | Symbol | Min. | Typ. | Max. | Unit | Test Condition |
|----------------------------------|-------------------|------|------|------|------|-------------------------------|
| Luminous Intensity | I _v | 40 | 80 | --- | mcd | I _F =20mA (Note 1) |
| Viewing Angle | 2θ _{1/2} | 170 | 180 | --- | Deg | (Note 2) |
| x,y coordinates (CIE 1931 2) | x | --- | 0.53 | --- | --- | I _F =20mA (Note 3) |
| | y | --- | 0.24 | --- | --- | I _F =20mA (Note 3) |
| Forward Voltage | V _F | --- | 3.3 | 4.0 | V | I _F =20mA |
| Reverse Current | I _R | --- | --- | 50 | μA | V _R =5V |

Notes:

- Luminous intensity is measured with a light sensor and filter combination that approximates the CIE eye-response curve.
- θ_{1/2} is the off-axis angle at which the luminous intensity is half the axial luminous intensity.
- The x and y parameters correspond to the CIE 1931 Chromaticity Diagram. X, Y, and Z are the tristimulus values calculated using the spectral distribution data.
- Forward voltage measurement allowance is ±0.1V
- Luminous Intensity Measurement Allowance is ±10%

**Typical Electrical / Optical Characteristics Curves
 (25°C Ambient Temperature Unless Otherwise Noted)**

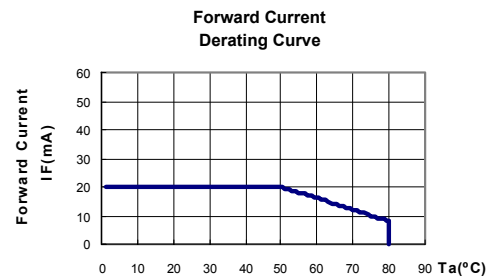
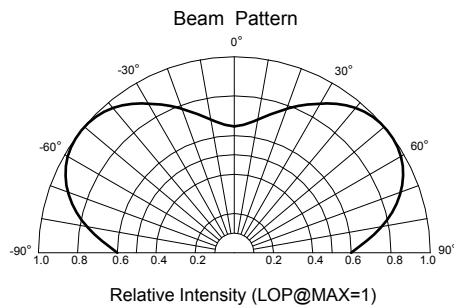
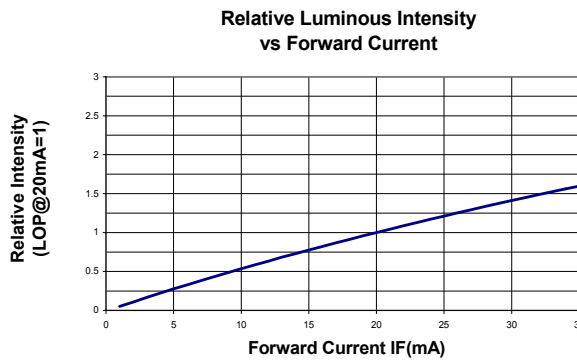
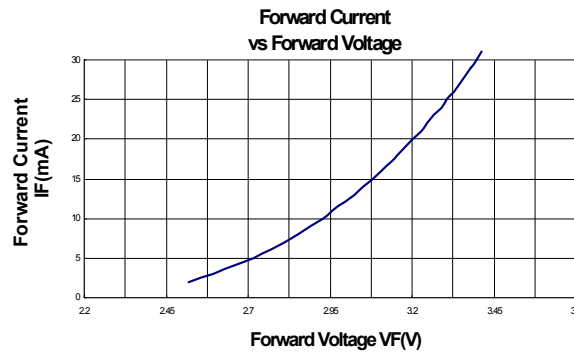
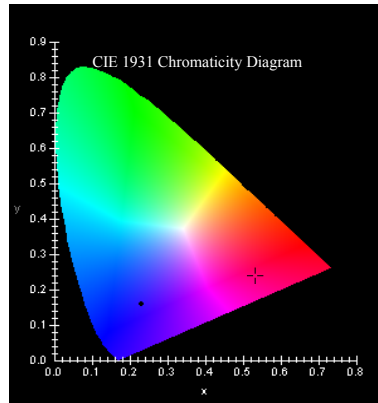

Downloaded from Elcodis.com electronic components distributor