

FEATURES

- Performs framing and monitoring functions
Supports Superframe and Extended Superframe formats
- Four onboard error counters
 - 16-bit bipolar violation
 - 8-bit CRC
 - 8-bit OOF
 - 8-bit frame bit error
- Indication of the following
 - yellow and blue alarms
 - incoming B8ZS code words
 - 8 and 16 zero strings
 - change of frame alignment
 - loss of sync
 - carrier loss
- Simple serial interface used for configuration, control and status monitoring
- Burst mode allows quick access to counters for status updates
- Automatic counter reset feature
- Single 5V supply; low-power CMOS technology
- Available in 28-pin DIP and 28-pin PLCC
- The DS2182A is upward-compatible from the original DS2182

The updated DS2182A includes the following changes from the original DS2182:

- Ability to count excessive zeros
- Severely Errored Framing Event indication
- Updated AIS detection
- Updated RCL detection
- AIS and RCL alarm clear indications

PIN ASSIGNMENT

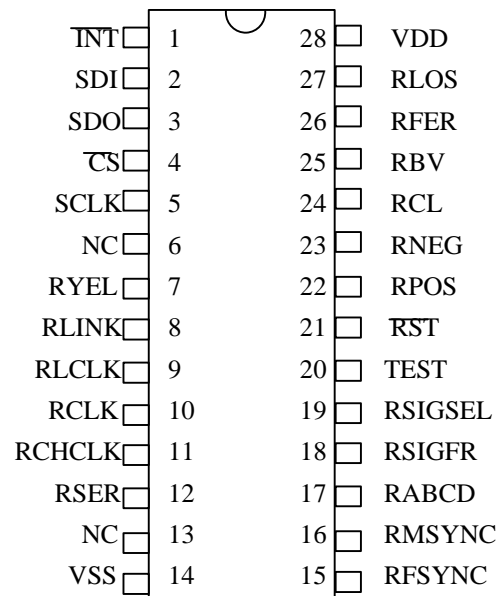

28-Pin DIP (600-mil)

DESCRIPTION

The DS2182A T1 Line Monitor Chip is a monolithic CMOS device designed to monitor real-time performance on T1 lines. The DS2182A frames to the data on the line, counts errors, and supplies detailed information about the status and condition of the line. Large on-board counters allow the accumulation of errors for extended periods, which permits a single CPU to monitor a number of T1 lines. Output clocks that are synchronized to the incoming data stream are provided for easy extraction of S-Bits, FDL bits, signaling bits, and channel data. The DS2182A meets the requirements of ANSI T1.231.

DS2182A BLOCK DIAGRAM Figure 1

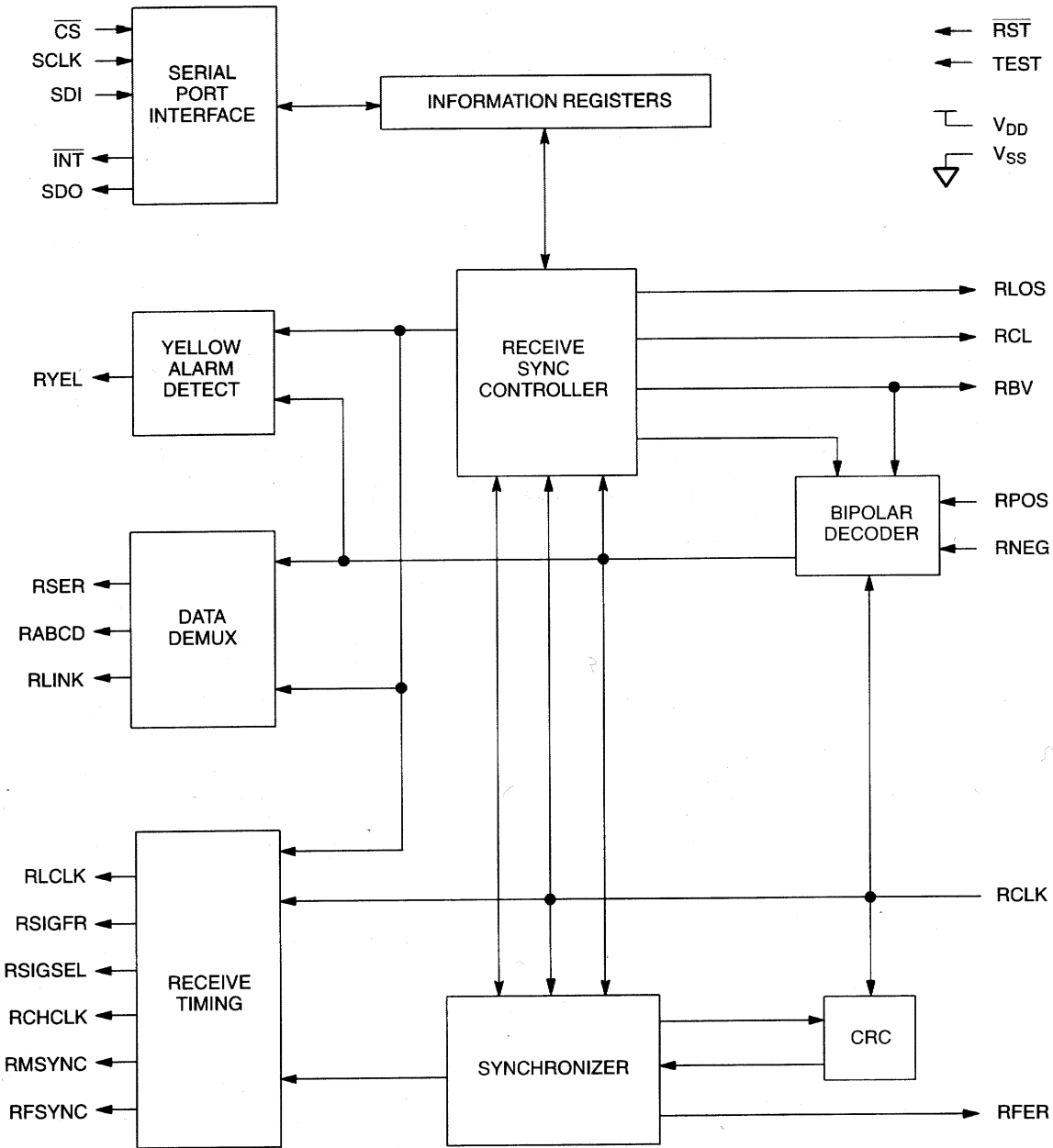

PIN DESCRIPTION Table 1

PIN	SYMBOL	TYPE	DESCRIPTION
6	NC	-	No Connect. No internal connection. This pin can be tied to either V _{SS} or V _{DD} , or it can be floated.
7	RYEL	O	Receive Yellow Alarm. Transitions high when yellow alarm detected; goes low when alarm clears.
8	RLINK	O	Receive Link Data. Updated with extracted FDL data one RCLK before start of odd frames (193E) and held until next update. Updated with extracted S-bit data one RCLK before start of even frames (193S) and held until next update.
9	RLCLK	O	Receive Link Clock. 4 kHz demand clock for RLINK.
10	RCLK	I	Receive Clock. 1.544 MHz primary clock.
11	RCHCLK	O	Receive Channel Clock. 192 kHz clock; identifies time slot (channel) boundaries.
12	RSER	O	Receive Serial Data. Received NRZ serial data; updated on rising edges of RCLK.
13	NC	-	No Connect. No internal connection. This pin can be tied to either V _{SS} or V _{DD} , or it can be floated.
15	RFSYNC	O	Receive Frame Sync. Extracted 8 kHz clock, one RCLK wide; F-bit position in each frame.
16	RMSYNC	O	Receive Multiframe Sync. Extracted multiframe sync; positive-going edge indicates start of multiframe; 50% duty cycle.
17	RABCD	O	Receive ABCD Signaling. Extracted signaling data output; valid for each channel in signaling frames. In non-signaling frames, RABCD outputs the LSB of each channel word.
18	ESIGFR	O	Receive Signaling Frame. High during signaling frames; low during non-signaling frames (and during resync).
19	RSIGSEL	O	Receive Signaling Select. In 193E framing, a .667 kHz clock that identifies signaling frames A and C; a 1.33 kHz clock in 193S.
21	$\overline{\text{RST}}$	I	Reset. A high-low transition clears all internal registers and resets counters. A high-low-high transition initiates a resync.
22 23	RPOS RNEG	I	Receive Bipolar Data Inputs. Sampled on falling of RCLK. Tie together to receive NRZ data and disable bipolar violation monitoring circuitry.
24	RCL	O	Receive Carrier Loss. High if 192 consecutive 0s appear at RPOS and RNEG; goes low upon seeing 12.5% one's density.
25	RBV	O	Receive Bipolar Violation. High during accused bit time at RSER. If bipolar violation detected, low otherwise.
26	RFER	O	Receive Frame Error. High during F-bit time when FT or FS errors occur (193S), or when FPS or CRC errors occur (193E). Low during resync.
27	RLOS	O	Receive Loss of Sync. Indicates sync status; high when internal resync is in progress, low otherwise.

PIN DESCRIPTION Table 2

PIN	SYMBOL	TYPE	DESCRIPTION
1	$\overline{\text{INT}}$	O	Receive Alarm Interrupt. Flags host controller during alarm conditions. Active low; open drain output.
2	SDI	I	Serial Data In. Data for onboard registers. Sampled on rising edge of SCLK.
3	SDO	O	Serial Data Out. Control and status information from onboard registers. Updated on falling edge of SCLK; tri-stated during serial port write or when CS is high.
4	$\overline{\text{CS}}$	I	Chip Select. Must be low to read or write the serial port.
5	SCLK	I	Serial Data Clock. Used to read or write the serial port registers.

POWER AND TEST PIN DESCRIPTION Table 3

PIN	SYMBOL	TYPE	DESCRIPTION
14	V_{SS}	-	Signal Ground. 0.0 volts.
20	TEST	I	Test Mode. Tie to V_{SS} for normal operation.
28	V_{DD}	-	Positive Supply. 5.0 volts.

REGISTER SUMMARY Table 4

REGISTER	ADDRESS	DESCRIPTION/FUNCTION
BVCR2	0000	Bipolar Violation Count Register 2. LSW of a 16-bit presetable counter that records individual bipolar violations.
BVCR1	0001	Bipolar Violation Count Register 1. MSW of a 16-bit presetable counter that records individual bipolar violations.
CRCCR	0010	CRC Error Count Register. 8-bit presetable counter that records CRC6 errored words in the 193E frame mode.
OOF CR	0011	OOF Count Register. 8-bit presetable counter that records OOF events. OOF events are defined by RCR1.5 and RCR1.6.
FE CR	0100	Frame Error Count Register. 8-bit presetable counter that records individual bit errors in the framing pattern.
RSR1	0101	Receive Status Register 1. Reports alarm conditions.
RIMR1	0110	Receive Interrupt Mask Register 1. Allows masking of individual alarm-generated interrupts from RSR1.
RSR2	0111	Receive Status Register 2. Reports alarm conditions.
RIMR2	1000	Receive Interrupt Mask Register 2. Allows masking of individual alarm-generated interrupts from RSR2.
RCR1	1001	Receive Control Register 1. Programs device operating characteristics.
RCR2	1010	Receive Control Register 2. Programs device operating characteristics.

SERIAL PORT INTERFACE

The port pins of the DS2182A serve as a microprocessor/ microcontroller-compatible serial port. Eleven on-board registers allow the user to update operational characteristics and monitor device status via a host controller, minimizing hardware interfaces. The port on the DS2182A can be read from or written to at any time. Serial port reads and writes are independent of T1 line timing signals RCLK, RPOS, and RNEG. However, RCLK is needed in order to clear RSR1 and RSR2 after reads.

ADDRESS/COMMAND

Reading or writing the control, configuration or status registers requires writing one address/command byte prior to transferring register data. The first bit written (LSB) of the address/command word specifies

register read or write. The following 4 bits identify the register address. The next 2 bits are reserved and must be set to 0 for proper operation. The last bit of the address/ command word enables burst mode when set; the burst mode causes all registers to be consecutively read or written to. Data is read and written to the DS2182A LSB first.

CHIP SELECT AND CLOCK CONTROL

All data transfers are initiated by driving the \overline{CS} input low. Input data is latched on the rising edge of SCLK and must be valid during the previous low period of SCLK to prevent momentary corruption of register data during writes. Data is output on the falling edge of SCLK and held to the next falling edge. All data transfers are terminated if the \overline{CS} input transitions high. Port control logic is disabled and SDO is tri-stated when \overline{CS} is high.

DATA I/O

Following the eight SCLK cycles that input an address/command byte to write, a data byte is strobed into the addressed register on the rising edge of the next eight SCLK cycles. Following an address/command word to read, contents of the selected register are output on the falling edges of the next eight SCLK cycles. The SDO pin is tri-stated during device write and can be tied to SDI in applications where the host processor has a bi-directional I/O pin.

BURST MODE

The burst mode allows all onboard registers to be consecutively written to or read by the host processor. A burst read is used to poll all registers; RSR1 and RSR2 contents will be unaffected. This feature minimizes device initialization time on system power-up or reset. Burst mode is initiated when ACB.7 is set and the address is 0000. A burst is terminated by a low-high transition on \overline{CS} .

ACB: ADDRESS COMMAND BYTE Figure 2

MSB							LSB
BM	-	-	ADD3	ADD2	ADD1	ADD0	R/ \overline{W}

SYMBOL	POSITION	NAME AND DESCRIPTION
BM	ACB.7	Burst Mode. If set (and register address is 0000) burst read or write is enabled.
-	ACB.6	Reserved, must be 0 for operation.
-	ACB.5	Reserved, must be 0 for operation.
ADD3	ACB.4	MSB of register address.
ADD0	ACB.1	LSB of register address.
R/W	ACB.0	Read/Write Select. 0 = write addressed register 1 = read addressed register

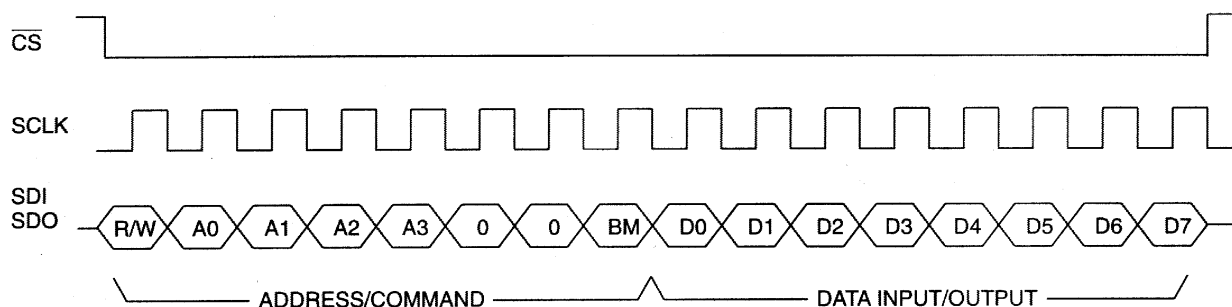
SERIAL PORT READ/WRITE Figure 3**NOTES:**

1. SDI is sampled on rising edge of SCLK.
2. SDO is updated on falling edge of SCLK.

OPERATION OF THE COUNTERS

All four of the counters in the DS2182A can be preset by the user to establish an event count interrupt threshold. The counters count up from the preset value until they reach saturation. At saturation, each additional event occurrence sets the appropriate bit in RSR2 and generates an interrupt if enabled by RIMR2.

The DS2182A contains an auto counter reset feature in the burst read mode. If RCR1.4 is set, then the user can burst read the four counters (five registers), and all four counters will be automatically reset to 0 after the read takes place. Since the burst mode can be terminated at any time by taking $\overline{\text{CS}}$ high, the user has the option of reading all of the registers or only the counters. If RCR1.4 is set, then any read of the registers, burst mode or not, will clear the count in all four counters. If the user wishes to read the port and not clear the counters, then RCR1.4 must be cleared first.

The counter registers can be read or written to at any time with the serial port, which operates totally asynchronously with the monitoring of the T1 line. Reading a register will not affect the count as long as RCR1.4 is cleared. The dual buffer architecture of the DS2182A insures that no error events will be missed while the serial port is being accessed for reads.

**BVCR1: BIPOLAR VIOLATION COUNT REGISTER 1;
 BVCR2: BIPOLAR VIOLATION COUNTER REGISTER 2 Figure 4**
MSB**LSB**

BV7	BV6	BV5	BV4	BV3	BV2	BV1	BV0
-----	-----	-----	-----	-----	-----	-----	-----

SYMBOL	POSITION	NAME AND DESCRIPTION
BV7	BVCR.7	MSB of bipolar violation count
BV0	BVCR.0	LSB of bipolar violation count

Bipolar Violation Count Register 1 (BVCR1) is the most significant word and BVCR2 is the least significant word of a presetable 16-bit counter that records individual bipolar violations. If the B8ZS mode is enabled (RCR2.2 = 1), then B8ZS code words are not counted. The BVCR can also be programmed to count excessive zeros by setting the RCR2.5 bit. In this mode, the BVCR will count

occurrences of 8 consecutive zeros when B8ZS is enabled or 16 consecutive zeros when B8Z5 is disabled. This counter increments at all times and is not disabled by a loss of sync condition (RLOS = 1). The counter saturates at 65,535 and generates an interrupt for each occurrence after saturation if RIMR2.0 is set.

NOTE:

1. In order to properly preset the Bipolar Violation Count Register, BVCR2 must be written to before BVCR1 is written to.

CRCCR: CRC COUNT REGISTER 2 Figure 5

MSB							LSB
CRC7	CRC6	CRC5	CRC4	CRC3	CRC2	CRC1	CRC0

SYMBOL	POSITION	NAME AND DESCRIPTION
CRC7	CRCCR.7	MSB of CRC6 word error count
CRC0	CRCCR.0	LSB of CRC6 word error count

The CRC Count Register (CRCCR) is an 8-bit presettable counter that records word errors in the Cyclic Redundancy Check (CRC). This 8-bit binary counter saturates at 255 and generates an interrupt for each occurrence after saturation if RIMR2.1 is set. The count in this register is only valid in the 193E framing mode (RCR2.4 = 1) and is reset and disabled in the 193S framing mode (RCR2.4 = 0). The count is disabled during a loss of sync condition (RLOS = 1).

OOF CR: OOF COUNT REGISTER Figure 6

MSB							LSB
OOF7	OOF6	OOF5	OOF4	OOF3	OOF2	OOF1	OOF0

SYMBOL	POSITION	NAME AND DESCRIPTION
OOF7	OOF CR.7	MSB of OOF event count
OOF0	OOF CR.0	LSB of OOF of event count

The OOF Count Register (OOF CR) is an 8-bit presettable counter that records Out Of Frame (OOF) events. OOF events are defined by RCR1.5 and RCR1.6. This 8-bit counter saturates at 255 and generates an interrupt for each occurrence after saturation if RIMR2.2 is set. The count is disabled during a loss of sync condition (RLOS = 1).

FECR: FRAME ERROR COUNT REGISTER Figure 7

MSB							LSB
FE7	FE6	FE5	FE4	FE3	FE2	FE1	FE0

SYMBOL	POSITION	NAME AND DESCRIPTION
FE7	FECR.7	MSB of frame error count
FE0	FECR.0	LSB of frame error count

The Frame Error Count Register (FECR) is an 8-bit pre-settable counter that records individual frame bit errors. In the 193E mode (RCR2.4 = 1), the FECR records bit errors in the FPS framing pattern (001011). In the 193S mode (RCR2.4 = 0), the FECR records bit errors in both the FT (101010) and FS (001110) framing patterns if RCR1.3 is set. If RCR1.3 is cleared, then the FECR only records bit errors in the FT pattern. This 8-bit counter saturates at 255 and generates an interrupt for each occurrence after saturation if RIMR2.3 is set. The count is disabled during a loss of sync condition (RLOS = 1).

RSR1: RECEIVE STATUS REGISTER 1 Figure 8

MSB							LSB
8ZD	16ZD	RCL	RYEL	RLOS	B8ZSD	RBL	COFA

SYMBOL	POSITION	NAME AND DESCRIPTION
8ZD	RSR1.7	8 Zero Detect. Set when a string of eight consecutive 0s has been received at RPOS and RNEG.
16ZD	RSR1.6	16 Zero Detect. Set when a string of 16 consecutive 0s has been received at RPOS and RNEG.
RCL	RSR1.5	Receive Carrier Loss. Set when a string of 192 consecutive 0s has been received at RPOS and RNEG. Cleared when 14 or more ones out of 112 possible bit positions are received.
RYEL	RSR1.4	Receive Yellow Alarm. Set when yellow alarm is detected. The format of yellow alarm is determined by RCR2.3 and RCR2.4.
RLOS	RSR1.3	Receive Loss of Sync. Set when resync is in progress.
B8ZSD	RSR1.2	B8ZS Code Word Detect. Set when a B8ZS code word is received at RPOS and RNEG independent of whether the B8ZS mode is enabled or not (RCR2.2).
RBL	RSR1.1	Receive Blue Alarm. Set when over a 3 ms window, 5 or less zeros are received. Cleared when over a 3 ms window, 6 or more zeros are received.
COFA	RSR1.0	Change of Frame Alignment. Set when the last resync resulted in a change of frame or multiframe alignment.

NOTE:

- Alarm 8ZD and 16ZD are cleared on the next occurrence of a 1 at RPOS and RNEG.

RECEIVE STATUS REGISTERS

The receive status registers (RSR1 and RSR2) can be used in either a polled or an interrupt configuration. In a polled configuration, the user reads the RSR at regular intervals to check for alarms. In an interrupt configuration, the user monitors the $\overline{\text{INT}}$ pin. When the $\overline{\text{INT}}$ pin goes low, an alarm condition has occurred and has been reported in one of the RSRs. The processor can then read the RSRs to find which bits have been set. All of the bits in the RSRs operate in a latched fashion. That is, once set, they remain set until read. The bits in the RSR are cleared when read unless the read was performed in the burst mode or the alarm condition still exists.

YELLOW ALARM

193S BIT 2. If $\text{RCR2.4} = 0$ and $\text{RCR2.3} = 0$, then the DS2182A examines bit 2 of all incoming channels for the presence of a yellow alarm. If bit 2 is set to 0 in 256 consecutive channels, then the reception of a yellow alarm is declared. The alarm is considered cleared when the first channel with bit 2 set to a 1 is received.

193S S-BIT. If $\text{RCR2.4} = 0$ and $\text{RCR2.3} = 1$, then the DS2182A examines the S-bit position of frame 12 for the presence of a yellow alarm. The DS2182A declares the presence of a yellow alarm on the first occurrence of the S-bit in frame 12 being set to 1. The alarm is considered cleared when this S-bit returns to 0.

193E FDL. If $\text{RCR2.4} = 1$, then the DS2182A examines the FDL for a repeating 00FF pattern. If this pattern is received in the FDL 16 consecutive times without error, then a yellow alarm is declared. The alarm is considered cleared as soon as any pattern other than 00FF is received.

RIMR1: RECEIVE INTERRUPT MASK REGISTER 1 Figure 9

MSB						LSB	
8ZD	16ZD	RCL	RYEL	RLOS	B8ZSD	RBL	COFA

SYMBOL	POSITION	NAME AND DESCRIPTION
8ZD	RIMR1.7	8 Zero Detect Mask. 1 = interrupt enabled. 0 = interrupt masked.
16ZD	RIMR1.6	16 Zero Detect Mask. 1 = interrupt enabled. 0 = interrupt masked.
RCL	RIMR1.5	Receive Carrier Loss Mask. 1 = interrupt enabled. 0 = interrupt masked.
RYEL	RIMR1.4	Receive Yellow Alarm Mask. 1 = interrupt enabled. 0 = interrupt masked.
RLOS	RIMR1.3	Receive Loss of Sync Mask. 1 = interrupt enabled. 0 = interrupt masked.
B8ZSD	RIMR1.2	B8ZS Code Word Detect Mask. 1 = interrupt enabled. 0 = interrupt masked.
RBL	RIMR1.1	Receive Blue Alarm Mask. 1 = interrupt enabled. 0 = interrupt masked.
COFA	RIMR1.0	Change of Frame Alignment Mask. 1 = interrupt enabled. 0 = interrupt masked.

RSR2: RECEIVE STATUS REGISTER 2 Figure 10

MSB				LSB			
SEFE	RCLC	RBLC	FERR	FECS	OOFS	CRCCS	BPVCS
SYMBOL	POSITION	NAME AND DESCRIPTION					
SEFE	RSR2.7	Severely Errored Framing Event. Set when 2 out of 6 framing bits (Ft or FPS) are received in error.					
RCLC	RSR2.6	Receive Carrier Loss Clear. Set when the carrier signal is restored; will remain set until read.					
RBLC	RSR2.5	Receive Blue Alarm Clear. Set when the Blue Alarm (AIS) is no longer detected; will remain set until read.					
FERR	RSR2.4	Frame Bit Error. Set when FT (193S) or FPS (193E) bit errors occur.					
FECS	RSR2.3	Frame Error Count Saturation. Set on the next frame error event after the 8-bit Frame Error Count Register (FECR) saturates at 255.					
OOFC	RSR2.2	Out Of Frame Count Saturation. Set on the next OOF event after the 8-bit OOF Count Register (OOFCR) saturates at 255.					
CRCCS	RSR2.1	CRC Count Saturation. Set on the next CRC error event after the 8-bit CRC Count Register (CRCCR) saturates at 255.					
BPVCS	RSR2.0	Bipolar Violation Count Saturation. Set on the next BPV error event after the 16-bit Bipolar Violation Count Register (BVCR) saturates at 65,535.					

RIMR2: RECEIVE INTERRUPT MASK REGISTER 2 Figure 11

MSB				LSB			
SEFE	RCLC	RBLC	FERR	FECS	OOFS	CRCCS	BPVCS
SYMBOL	POSITION	NAME AND DESCRIPTION					
SEFE	RIMR2.7	Severely Errored Framing Event Mask. 0 = interrupt masked 1 = interrupt enabled					
RCLC	RIMR2.6	Receive Carrier Loss Clear Mask. 0 = interrupt masked 1 = interrupt enabled					
RBLC	RIMR2.5	Receive Blue Alarm Clear Mask. 0 = interrupt masked 1 = interrupt enabled					

SYMBOL	POSITION	NAME AND DESCRIPTION
FERR	RIMR2.4	Frame Bit Error Mask. 1 = interrupt enabled 0 = interrupt masked
FECS	RIMR2.3	Frame Error Count Saturation Mask. 1 = interrupt enabled 0 = interrupt masked
OOFCS	RIMR2.2	Out Of Frame Count Saturation Mask. 1 = interrupt enabled 0 = interrupt masked
CRCCS	RIMR2.1	CRC Count Saturation Mask. 1 = interrupt enabled 0 = interrupt masked
BPVCS	RIMR2.0	Bipolar Violation Count Saturation Mask. 1 = interrupt enabled 0 = interrupt masked

RCR1: RECEIVE CONTROL REGISTER 1 Figure 12

MSB

LSB

ARC	OOF1	OOF2	ACR	SYNCC	SYNCT	SYNCE	RESYNC
-----	------	------	-----	-------	-------	-------	--------

SYMBOL	POSITION	NAME AND DESCRIPTION
ARC	RCR1.7	Auto Resync Criteria. 1 = resync on OOF event only 0 = resync on OOF event or Receive Carrier Loss (RCL)
OOF1	RCR1.6	Out Of Frame 1. OOF event description. Valid when RCR1.5 is cleared 1 = 2 out of 5 frame bits (FT or FPS) in error 0 = 2 out of 4 frame bits (FT or FPS) in error
OOF2	RCR1.5	Out Of Frame 2. OOF event description. 1 = 2 out of 6 frame bits (FT or FPS) in error 0 = follow OOF event described in RCR1.6
ACR	RCR1.4	Auto Counter Reset. When set, all four of the counters will be reset to 0 when read.

SYMBOL	POSITION	NAME AND DESCRIPTION
SYNCC	RCR1.3	<p>Sync Criteria. Determines the type of algorithm utilized by the receive synchronizer; differs for each frame mode.</p> <p>193S Framing (RCR2.4 = 0) 0 = synchronize to frame boundaries using FT pattern, then search for multiframe by using FS. 1 = cross couple FT and FS patterns in sync algorithm.</p> <p>193E Framing (RCR2.4 = 1) 0 = normal sync (utilizes FPS only). 1 = validate new alignment with CRC before declaring sync.</p>
SYNCT	RCR1.2	<p>Sync Time. 1 = validate 24 consecutive F-bits before declaring sync. 0 = validate 10 consecutive F-bits before declaring sync.</p>
SYNCE	RCR1.1	<p>Sync Enable. If clear, the DS2182A automatically begins a resync if the conditions described in RCR1.7 are met. If set, no auto resync occurs.</p>
RESYNC	RCR1.0	<p>Resync. When toggled low to high, the DS2182A initiates a resync immediately. The bit must be cleared and set again for subsequent resyncs.</p>

SYNCHRONIZER

The heart of the monitor is the receive synchronizer. This circuit serves two purposes: 1) monitors the incoming data stream for loss of frame or multiframe alignment, and 2) searches for new frame alignment pattern when sync loss is detected. When sync loss is detected, the synchronizer begins an off-line search for the new alignment; all output timing signals remain at the old alignment with the exception of RSIGFR, which is forced low during resync. When one and only one candidate is qualified, the output timing moves to the new alignment at the beginning of the next multiframe. One frame later, RLOS will transition low, indicating valid sync and the resumption of the normal sync monitoring mode. Several bits in the RCR1 allow tailoring of the resync algorithm by the user. These bits are described below.

SYNC CRITERIA (RCR1.3)

193E. Bit RCR1.3 determines which sync algorithm is utilized when resync is in progress (RLOS = 1). In 193E framing, when RCR1.3 = 0, the synchronizer will lock only to the FPS pattern and will move to the new frame and multiframe alignment after the framing candidate is qualified. RLOS will go low one frame after the move to the new alignment. When RCR1.3 = 1, the new alignment is further tested by a CRC6 code match. RLOS will transition low after a CRC6 match occurs. If no CRC6 match occurs in three attempts (three multiframe), the algorithm resets and a new search for the FPS pattern begins. It takes 9 ms for the synchronizer to check the first CRC6 code after the new FPS alignment has been loaded. Each additional CRC6 test takes 3 ms. Regardless of the state of RCR1.3, if more than one candidate exists after 24 ms, the synchronizer begins eliminating emulators by testing their CRC6 codes in order to find the true framing candidate.

193S. In 193S framing, when RCR1.3 = 1, the synchronizer cross-checks the FT pattern with the FS pattern to help eliminate false framing candidates such as digital milliwatts. The FS patterns are compared to the repeating pattern ...00111000111000...(00111x0 if RCR2.3 = 1). In this mode, FT and FS must be correctly identified by the synchronizer before sync is declared. Clearing RCR1.3 causes the synchronizer to search for the FT pattern (101010...) without cross-coupling the FS pattern. Frame sync

is established using the FT information, while multiframe sync is established only if valid FS information is present. If no valid FS pattern is identified, the synchronizer moves to the FT alignment, RLOS goes low, and a false multiframe position may be indicated by RMSYNC. RFER indicates when the received S-bit pattern does not match the assumed internal multiframe alignment. This mode will be used in applications where non-standard S-bit patterns exist. In such applications, multiframe alignment information can be decoded externally by using the S-bits present at RLINK.

SYNC TIME (RCR1.2)

Bit RCR1.2 determines the number of consecutive framing pattern bits to be qualified before SYNC is declared. If RCR1.2 = 1, the algorithm validates 24 bits; if RCR1.2 = 0, 10 bits are validated. Validating 24 bits results in superior false framing protection while 10-bit testing minimizes reframe time. In either case, the synchronizer only establishes resync when one and only one candidate is found (see Table 5).

AVERAGE REFRAME TIME Table 5

FRAME MODE	RCR1.2=0			RCR1.2=1		
	MIN	AVG.	MAX.	MIN.	AVG.	MAX
193S	3.0ms	3.75ms	4.5ms	6.5ms	7.25ms	8.0ms
193E	6.0ms	7.5ms	9.0ms	13.0ms	14.5ms	16.0ms

NOTE:

1. Average reframe time is defined here as the average time it takes from the start of resync (rising edge of RLOS) to the actual loading of the new alignment (on a multiframe edge) into the output receive timing.

SYNC ENABLE (RCR1.1)

When RCR1.1 is cleared, the receiver initiates automatic resync if an OOF event occurs or if carrier loss (192 consecutive 0s) occurs (depends on RCR1.7). When RCR1.1 is set, the automatic resync circuitry is disabled. In this case, resync can only be initiated by setting RCR1.0 to 1 or externally transitioning RST from low to high. Note that using RST to initiate a resync resets the output timing while RST is low; use of RCR1.1 will not affect the output timing until the new alignment is located.

RESYNC (RCR1.0)

A 0-to-1 transition of RCR1.0 causes the synchronizer to search for the framing pattern sequence immediately, regardless of the internal sync status. In order to initiate another resync command, this bit must be cleared and then set again.

RCR2: RECEIVE CONTROL REGISTER 2 Figure 13

MSB						LSB	
-	-	BVCRF	FM	SFYEL	B8ZS	-	-

SYMBOL	POSITION	NAME AND DESCRIPTION
-	RCR2.7	Reserved; must be 0 for proper operation.
-	RCR2.6	Reserved; must be 0 for proper operation.
BVCRF	RCR2.5	Bipolar Violation Count Register Function Select. 0 = do not count excessive 0s 1 = count excessive 0s
FM	RCR2.4	Frame Mode. 1 = Extended Superframe (193E, 24 frames per Superframe). 0 = Superframe (193S or D4, 12 frames per Superframe).
SFYEL	RCR2.3	SF Yellow Mode Select. 1 = 1 in the S-bit position of frame 12. 0 = 0 in bit 2 of all channels.
B8ZS	RCR2.2	Bipolar Eight Zero Substitution. 1 = B8ZS enabled. 0 = B8ZS disabled.
-	RCR2.1	Reserved; must be 0 for proper operation.
-	RCR2.10	Reserved; must be 0 for proper operation.

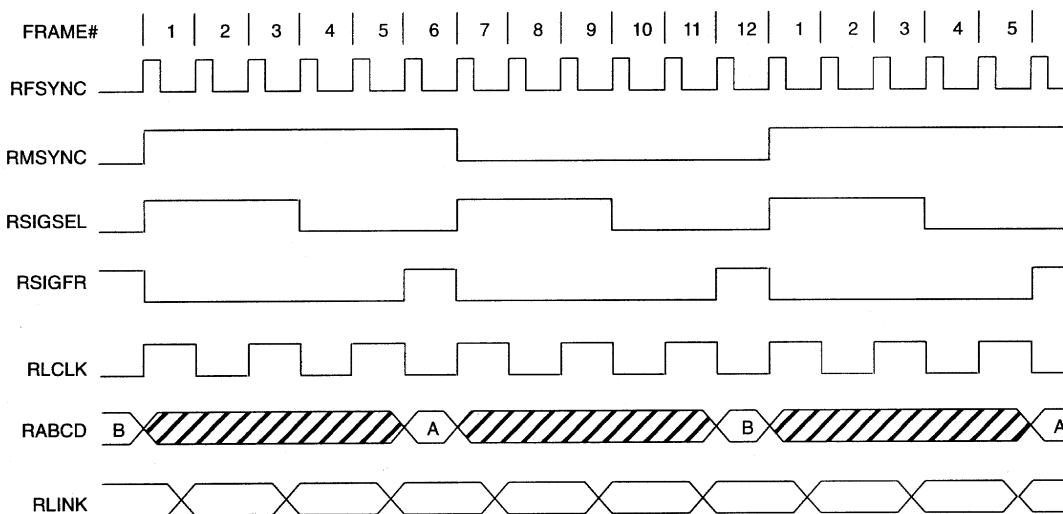
193S RECEIVE MULTIFRAME TIMING Figure 14**NOTES:**

1. Signaling data is updated during signaling frames on channel boundaries. Pin RABCD is the LSB of each channel word in non-signaling frames.
2. RLINK data (S-bit) is updated one bit-time prior to S-bit frames and held for two frames.

193E RECEIVE MULTIFRAME TIMING Figure 15

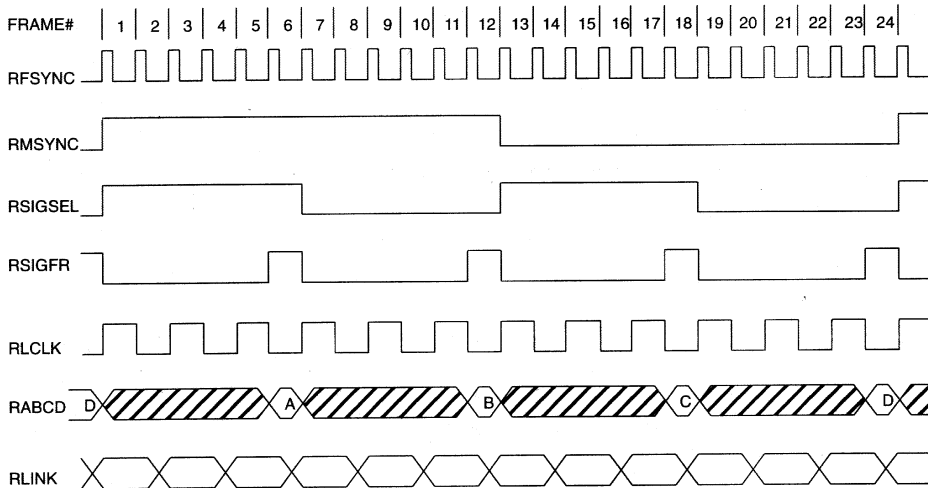

NOTES:

1. Signaling data is updated during signaling frames on channel boundaries. Pin RABCD is the LSB of each channel word in non-signaling frames.
2. RLINK data (FDL data) is updated one bit-time prior to odd frames and held for two frames.

RECEIVE MULTIFRAME BOUNDARY TIMING Figure 16

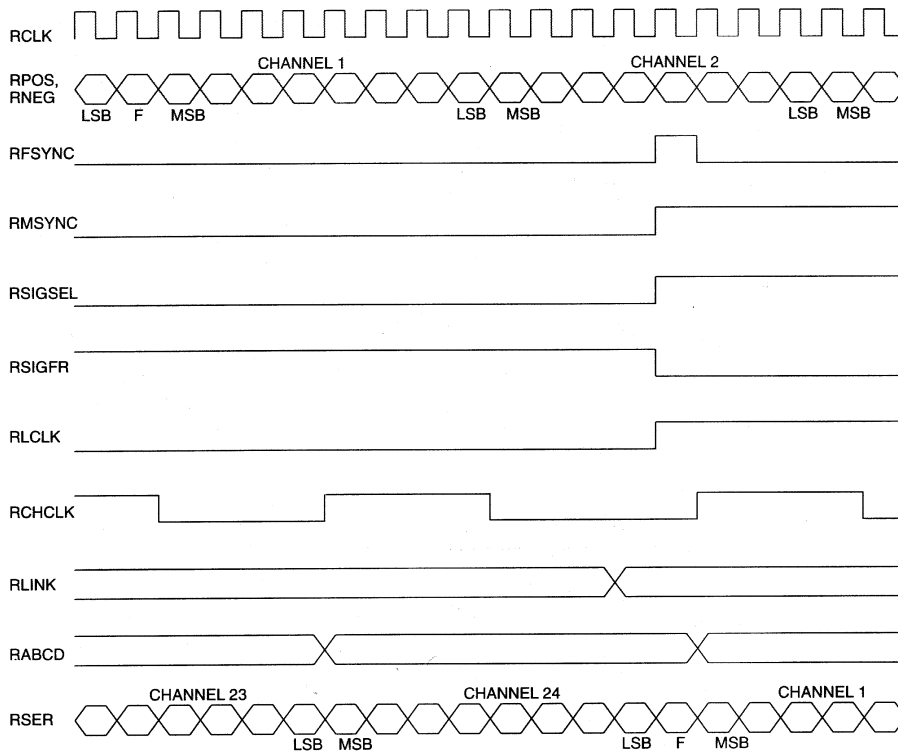

NOTES:

1. RLINK timing is shown for 193E; in 193S, RLINK is updated on even frame boundaries and is held across multiframe edges.
2. Total delay from RPOS and RNEG to RSER output is 13 RCLK periods.

ALARM OUTPUTS

The transceiver also provides direct alarm outputs for applications when additional decoding and demuxing are required to supplement the onboard alarm logic.

RLOS OUTPUT

The receive loss of sync output indicates the status of the receiver synchronizer circuitry; when high, an off-line resynchronization is in progress and a high-low transition indicates that resync is complete. The RLOS bit (RSR1.3) is a latched version of the RLOS output. If the auto-resync mode is selected (RCR1.1 = 0), RLOS is a real-time indication of a carrier loss or OOF event occurrence.

RYEL OUTPUT

The yellow alarm output transitions high when a yellow alarm is detected. A high-low transition indicates the alarm condition has been cleared. The RYEL bit (RSR1.4) is a latched version of the RYEL output.

RBV OUTPUT

The bipolar violation output transitions high when the accused bit emerges at RSER. RBV goes low at the next bit time if no additional violations are detected.

RFER OUTPUT

The receive frame error output transitions high at the F-bit time and is held high for 2 bit periods when a frame bit error occurs. In 193S, framing FT and FS patterns are tested. The FPS pattern is tested in 193E framing. Additionally, in 193E framing, RFER reports CRC6 code word errors by a low-high-low transition (1 bit period-wide) one-half RCLK period before a low-high transition on RMSYNC (see Figure 17).

RESET

A high-low transition on $\overline{\text{RST}}$ clears all registers and forces an immediate resync when $\overline{\text{RST}}$ returns high. $\overline{\text{RST}}$ must be held low on system power-up to insure proper initialization of the counters and registers. Following reset, the host processor should restore all control modes by writing appropriate registers with control data.

ALARM OUTPUT TIMING Figure 17

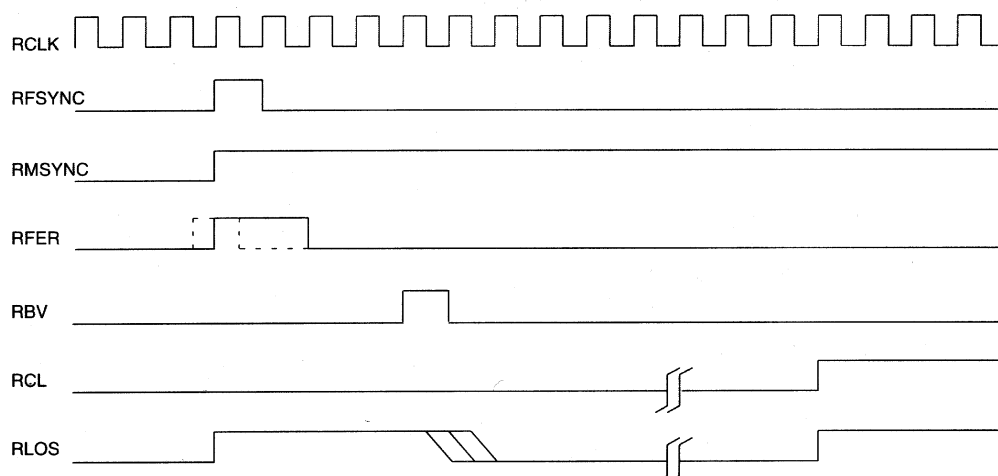

NOTES:

1. RFER transitions high during F-bit time if received framing pattern bit is in error. (Frame 12 F-bits in 193S are ignored if RCR2.3 = 1.) Also, in 193E, RFER transitions high 1/2 bit-time before rising edge of RMSYNC to indicate a CRC6 error for the previous multiframe.
2. RBV indicates received bipolar violation and transitions high when accused bit emerges from RSER. If B8ZS is enabled, RBV will not report the 0 replacement code.
3. RCL transitions high when 192 consecutive bits are 0; RCL transitions low upon reception of 12.5% ones density.
4. RLOS transitions high during F-bit time that caused an OOF event if auto-resync is enabled (RCR1.1 = 0). Resync also occurs when loss of carrier is detected (RCL = 1) if RCR1.7 = 0. When RCR1.1 = 1, RLOS remains low until resync occurs, regardless of OOF or carrier loss flags. In this situation, resync is initiated only when RCR1.0 transitions low-to-high or the $\overline{\text{RST}}$ pin transitions high-low-high.

ABSOLUTE MAXIMUM RATINGS*

Voltage on Any Pin Relative to Ground	-0.1V to +7.0V
Operating Temperature	0° to 70°C
Storage Temperature	-55°C to +125°C
Soldering Temperature	260°C for 10 seconds

* This is a stress rating only and functional operation of the device at these or any other conditions above those indicated in the operation sections of this specification is not implied. Exposure to absolute maximum rating conditions for extended periods of time may affect reliability.

RECOMMENDED DC OPERATING CONDITIONS (0°C to 70°C)

PARAMETER	SYMBOL	MIN	TYP	MAX	UNITS	NOTES
Input Logic 1	V _{IH}	2.0		V _{CC} +0.3	V	
Input Logic 0	V _{IL}	-0.3		+0.8	V	
Supply	V _{DD}	4.50		5.50	V	

DC ELECTRICAL CHARACTERISTICS (0°C to 70°C; V_{DD} = 5V ± 10%)

PARAMETER	SYMBOL	MIN	TYP	MAX	UNITS	NOTES
Supply Current	I _{DD}		3		mA	1,2
Input Leakage	I _L	-1.0		+1.0	μA	3
Output Current (2.4V)	I _{OH}	-1.0			mA	4
Output Current (0.4V)	I _{OL}	+4.0			mA	5
Output Leakage	I _{LO}	-1.0		+1.0	μA	6

CAPACITANCE (t_A=25°C)

PARAMETER	SYMBOL	MIN	TYP	MAX	UNITS	NOTES
Input Capacitance	C _{IN}			5	pF	
Output Capacitance	C _{OUT}			7	pF	

NOTES:

1. RCLK = 1.544 MHz.
2. Outputs open.
3. 0V < V_{IN} < V_{DD}.
4. All outputs except $\overline{\text{INT}}$ which is open collector.
5. All outputs.
6. Applies to SDO when tri-stated.

CHARACTERISTICS^{1,2} SERIAL PORT (0°C to 70°C; $V_{DD} = 5V \pm 10\%$)

PARAMETER	SYMBOL	MIN	TYP	MAX	UNITS	NOTES
SDI to SCLK Setup	t_{DC}	50			ns	
SCLK to SDI Hold	t_{CHD}	50			ns	
SDI to SCLK Falling Edge	t_{CD}	50			ns	
SCLK Low Time	t_{CL}	250			ns	
SCLK High Time	t_{CH}	250			ns	
SCLK Rise and Fall Times	t_R, t_F			100	ns	
\overline{CS} to SCLK Setup	t_{CC}	50			ns	
SCLK to \overline{CS} Hold	t_{CCH}	50			ns	
\overline{CS} Inactive Time	t_{CWH}	2.5			μs	
SCLK to SDO Valid	t_{CDV}			200	ns	
\overline{CS} to SDO High Z	t_{CDZ}			75	ns	

NOTES:

1. Measured at $V_{IH} = 2.0$ or $V_{IL} = .8$ and 10ns maximum rise and fall time.
2. Output load capacitance = 100 pF.

AC ELECTRICAL CHARACTERISTICS^{1,2} RECEIVE(0°C to 70°C; $V_{DD} = 5.0V \pm 10\%$)

PARAMETER	SYMBOL	MIN	TYP	MAX	UNITS	NOTES
Propagation delay RCLK to RMSYNC, RFSYNC, RSISEL, RSIGFR, RLCLK, RCHCLK	t_{PRS}			75	ns	
Propagation delay RCLK to RSER, RABCD, RLINK	t_{PRD}			75	ns	
Transition Time All Outputs	t_{TTR}			20	ns	
RCLK Period	t_p		648		ns	
RCLK Pulse Width	t_R, t_F		324		ns	
RCLK Rise and Fall Times	t_{CCH}		20		ns	
RPOS, RNEG Setup to RCLK Falling	t_{SRD}	50			ns	
RPOS, RNEG Hold to RCLK Falling	t_{HRD}	50			ns	
Propagation delay RCLK to RLOS, RYEL, RBV, RCL, RFER	t_{PRA}			75	ns	
Minimum \overline{RST} Pulse Width	t_{RST}	1			μs	

NOTES:

1. Measured at $V_{IH} = 2.0$ or $V_{IL} = .8$ and 10ns maximum rise and fall time.
2. Output load capacitance = 100 pF.

SERIAL PORT WRITE AC TIMING DIAGRAM Figure 18

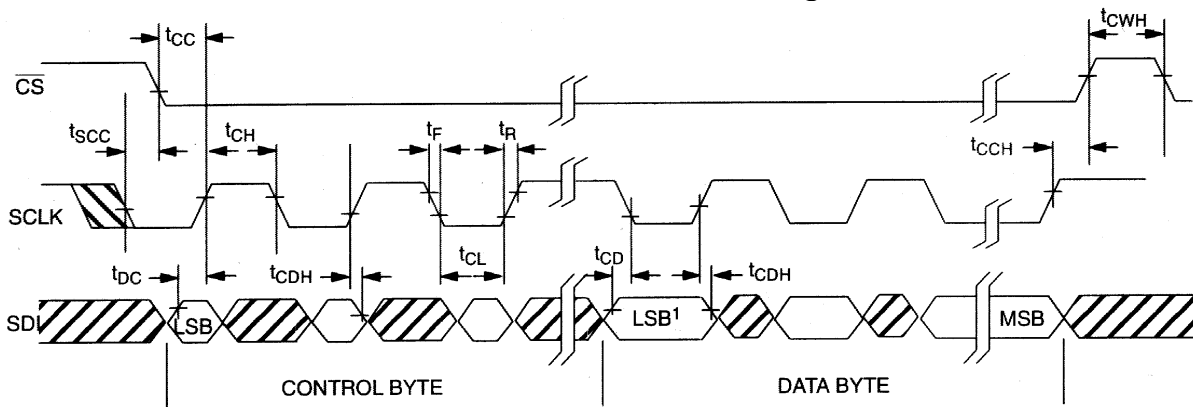

NOTES:

1. Data byte bits must be valid across low clock periods to prevent transients in operating modes.
2. Shaded regions indicate "don't care" states of input.

SERIAL PORT READ¹ AC TIMING DIAGRAM Figure 19

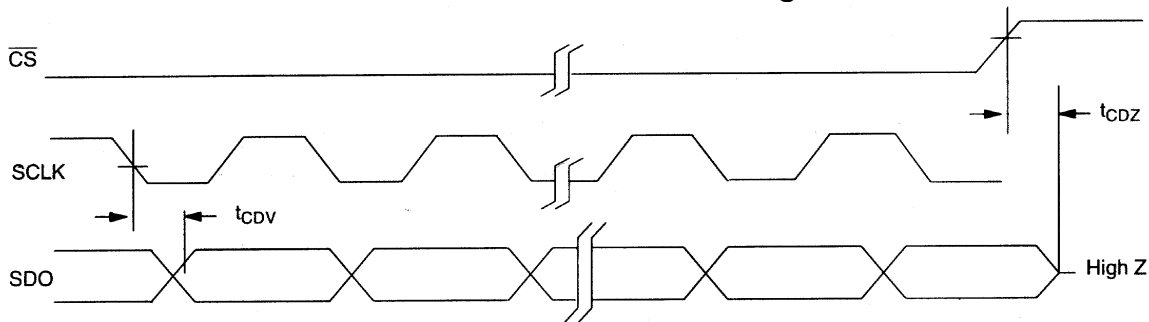

NOTES:

1. Serial port write must precede a port read to provide address information.

RECEIVE AC TIMING DIAGRAM Figure 20

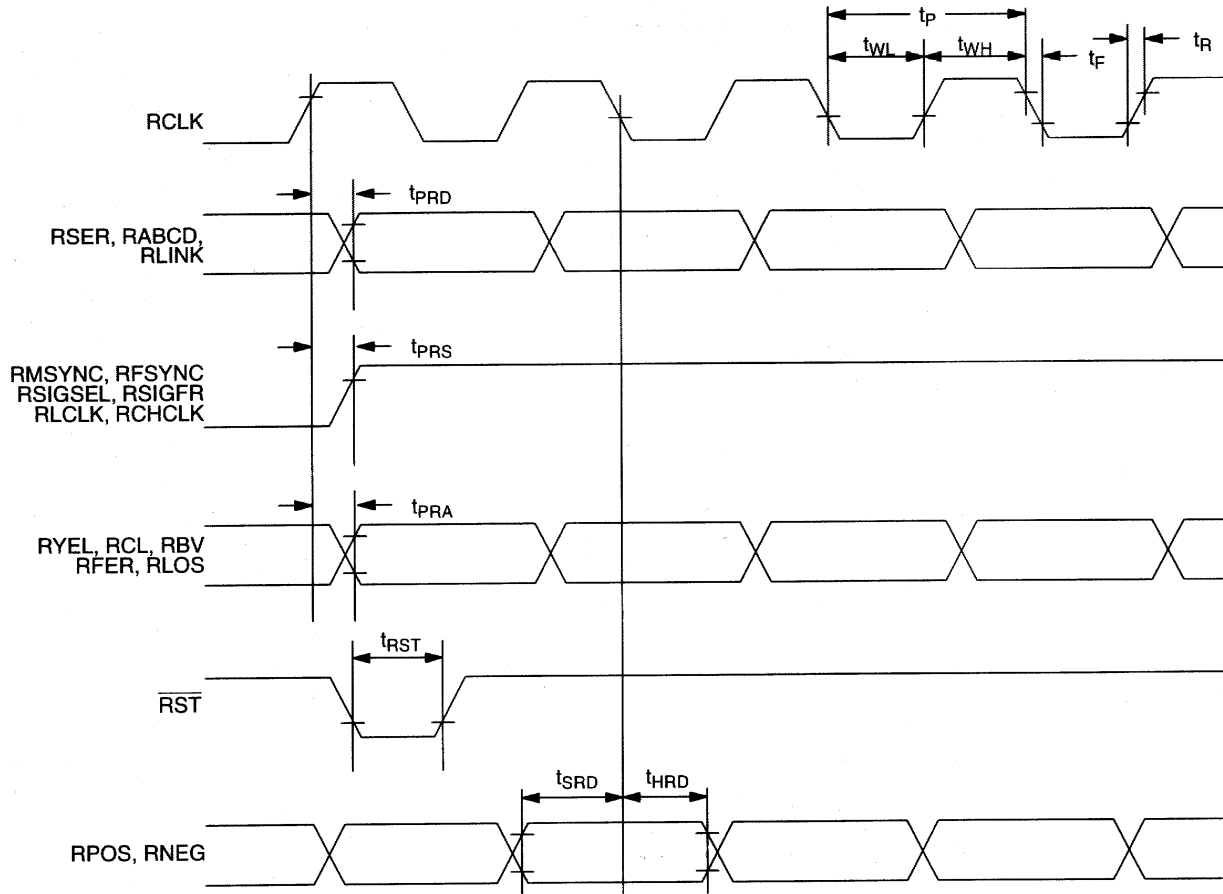

DS2182A T1 LINE MONITOR 28-PIN DIP

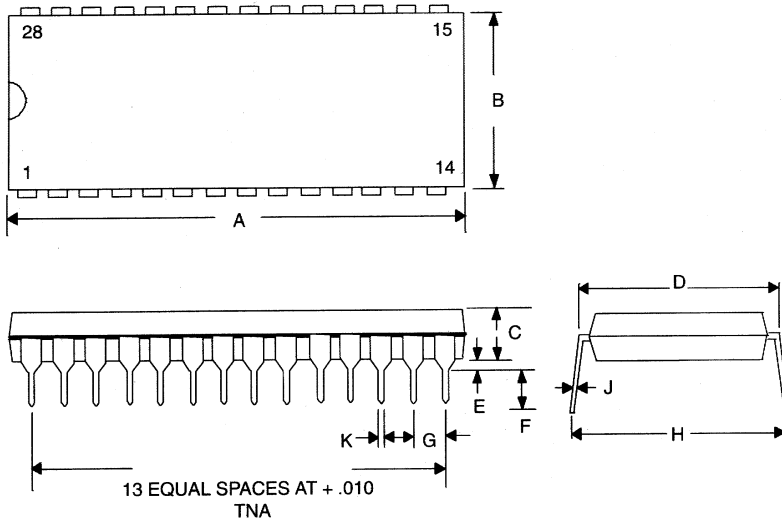

DIM	INCHES	
	MIN.	MAX.
A	1.445	1.470
B	0.530	0.550
C	0.140	0.160
D	0.600	0.625
E	0.015	0.040
F	0.120	0.145
G	0.090	0.110
H	0.600	0.680
J	0.008	0.012
K	0.015	0.022

DS2182AQ T1 LINE MONITOR 28-PIN PLCC

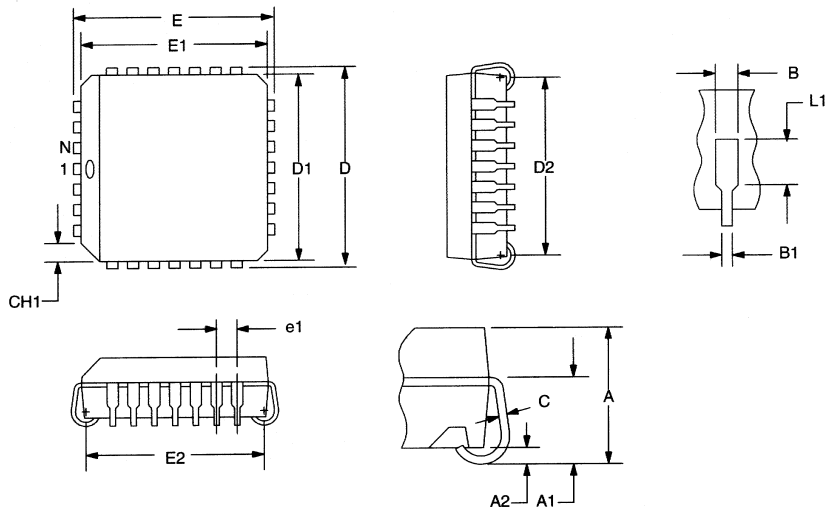

DIM	INCHES	
	MIN.	MAX.
A	0.165	0.180
A1	0.090	0.120
A2	0.020	-
B	0.026	0.033
B1	0.013	0.021
C	0.009	0.012
D	0.485	0.495
D1	0.450	0.456
D2	0.390	0.430
E	0.485	0.495
E1	0.450	0.456
E2	0.390	0.430
L1	0.060	-
N	28	-
e1	0.050 BSC	
CH1	0.042	0.048