



# RF5300

3V, 5GHz LINEAR POWER AMPLIFIER

## RoHS Compliant & Pb-Free Product

### Typical Applications

- IEEE802.11a/n WLAN Applications
- HyperLAN
- Wireless LAN Systems
- Commercial and Consumer Systems
- Portable Battery-Powered Equipment
- Spread-Spectrum and MMDS Systems

### Product Description

The RF5300 is a linear, medium-power, high-efficiency amplifier IC designed specifically for battery-powered WLAN applications such as PC cards, mini PCI, and compact flash applications. The device is manufactured on an advanced Gallium Arsenide Heterojunction Bipolar Transistor (HBT) process, and has been designed for use as the final RF amplifier in 5GHz WLAN and other spread-spectrum transmitters. The device is provided in a 16-pin leadless chip carrier with a backside ground. The RF5300 is designed to maintain linearity over a wide range of supply voltage and power output. The RF5300 is designed to reduce end-product BOM count by integrating all matching circuitry onto the chip.

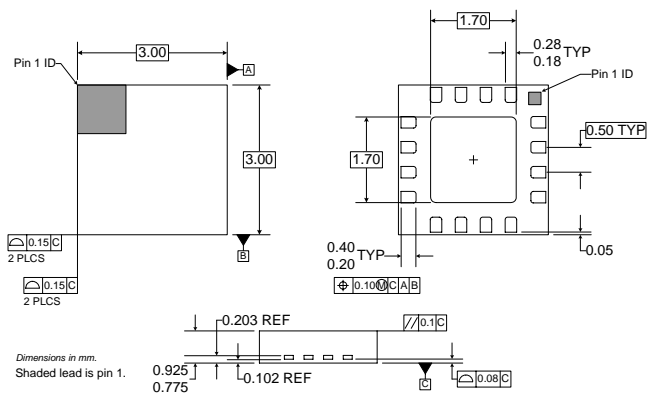

### Optimum Technology Matching® Applied

- |                                     |  |                                       |
|-------------------------------------|--|---------------------------------------|
| <input type="checkbox"/> Si BJT     | <input checked="" type="checkbox"/> GaAs HBT | <input type="checkbox"/> GaAs MESFET  |
| <input type="checkbox"/> Si Bi-CMOS | <input type="checkbox"/> SiGe HBT            | <input type="checkbox"/> Si CMOS      |
| <input type="checkbox"/> InGaP/HBT  | <input type="checkbox"/> GaN HEMT            | <input type="checkbox"/> SiGe Bi-CMOS |

Package Style: QFN, 16-Pin, 3x3

### Features

- Single Power Supply 3.0V to 5.0V
- 50Ω Input/Output Impedance
- 30dB Gain (typ. UNII-1 and 2)
- High Linearity
- 4900MHz to 5850MHz Frequency Range

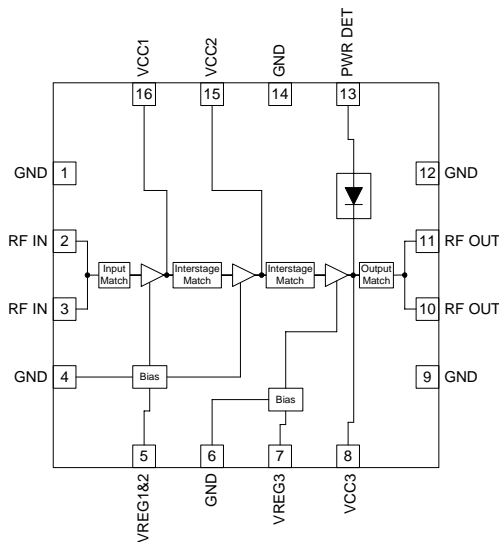

Functional Block Diagram

### Ordering Information

RF5300 3V, 5GHz Linear Power Amplifier  
 RF5300PCBA-41X Fully Assembled Evaluation Board

RF Micro Devices, Inc.  
 7628 Thorndike Road  
 Greensboro, NC 27409, USA

Tel (336) 664 1233  
 Fax (336) 664 0454  
<http://www.rfmd.com>

# RF5300

## Absolute Maximum Ratings

Parameter	Rating	Unit
Supply Voltage	-0.5 to +6.0	V <sub>DC</sub>
Power Control Voltage (V <sub>REG</sub> )	-0.5 to 3.5	V
DC Supply Current	600	mA
Input RF Power	+10	dBm
Operating Ambient Temperature	-40 to +85	°C
Storage Temperature	-40 to +150	°C
Moisture sensitivity	JEDEC Level 3	

Refer to "Handling of PSOP and PSSOP Products" on page 16-15 for special handling information.



**Caution!** ESD sensitive device.

RF Micro Devices believes the furnished information is correct and accurate at the time of this printing. RoHS marking based on EUDirective2002/95/EC (at time of this printing). However, RF Micro Devices reserves the right to make changes to its products without notice. RF Micro Devices does not assume responsibility for the use of the described product(s).

Parameter	Specification			Unit	Condition
	Min.	Typ.	Max.		
<b>Overall</b>					T=25°C, V <sub>CC</sub> =3.3V, V <sub>REG</sub> =2.8V, Freq=4900MHz to 5850MHz
Frequency Range		4900 to 5850		MHz	
Output Power					With 802.11a modulation (54Mbit/s) meeting spectral mask and EVM requirements
V <sub>CC</sub> =3.3V	16			dBm	F=4900MHz to 5000MHz,
	18			dBm	F=5700MHz to 5850MHz
EVM		2.7		%	F=5150MHz to 5350MHz
V <sub>CC</sub> =3.3V	18			dBm	F=4900MHz to 5850MHz
EVM			4	%	
V <sub>CC</sub> =5.0V	19	20		dBm	F=4900MHz to 5850MHz
EVM			4	%	
Gain (RF P <sub>OUT</sub> =+15dBm)	26	28		dB	F=4900MHz to 5000MHz
	29	30		dB	F=5150MHz to 5350MHz
	24	26		dB	F=5700MHz to 5850MHz
Power Detect (P <sub>detect</sub> ) Voltage	0.50	0.65	0.70	V <sub>DC</sub>	RF P <sub>OUT</sub> =+11dBm (4900MHz to 5850MHz)
	1.1	1.3	1.5	V <sub>DC</sub>	RF P <sub>OUT</sub> =+18dBm (4900MHz to 5850MHz)
	1.3	1.5	1.7	V <sub>DC</sub>	RF P <sub>OUT</sub> =+19dBm (4900MHz to 5850MHz)
<b>Power Supply</b>					
Operating Voltage		3.0 to 5.0		V	
Current Consumption		265		mA	P <sub>OUT</sub> =18dBm, V <sub>CC</sub> =3.3V, V <sub>REG</sub> =+2.8V
		195		mA	Idle current, V <sub>CC</sub> =3.3V, V <sub>REG</sub> =2.8V
V <sub>REG</sub> Current (Total)		5	10	mA	V <sub>CC</sub> =3.3V
		10	15	mA	V <sub>CC</sub> =5.0V

Pin	Function	Description	Interface Schematic
1	<b>GND</b>	Ground.	
2	<b>RF IN</b>	RF input. Input is matched to 50Ω and DC block is provided internally.	
3	<b>RFIN</b>	Same as pin 2.	See pin 2.
4	<b>GND</b>	Ground.	
5	<b>VREG1&amp;2</b>	First and second stage input bias. This pin requires a regulated supply to maintain nominal bias current.	
6	<b>VREG3/ GND</b>	Ground for third stage bias circuit. Attach to RF ground approximately 100mils to ground from package.	See pin 5.
7	<b>VREG3</b>	Third stage input bias. This pin requires a regulated supply to maintain a nominal bias current.	
8	<b>VCC3</b>	Third stage supply bias. This pin is sensitive to bypass capacitors which should be placed approximately 100mils from package and resonate 5GHz to ground.	
9	<b>GND</b>	Ground.	
10	<b>RF OUT</b>	RF output. Output is matched to 50Ω and DC block is provided.	
11	<b>RF OUT</b>	Same as pin 10.	See pin 10.
12	<b>GND</b>	Ground.	
13	<b>PWR DET</b>	Provides an output voltage proportional to the RF level.	
14	<b>GND</b>	Ground.	
15	<b>VCC2</b>	Supply voltage for the second stage. Bypass capacitor is needed to provide isolation from VCC1 and VCC3.	
16	<b>VCC1</b>	Supply voltage for the first stage.	
<b>Pkg Base</b>	<b>GND</b>	Ground connection. The backside of the package should be connected to the ground plane through a short path (i.e., vias under the device will be required).	

## Theory of Operation

The RF5300 is a three-stage device with a nominal gain of 28dB to 30dB in the 4.9GHz to 5.850GHz ISM band. The RF5300 is designed primarily for IEEE802.11a/n WLAN applications where the available supply voltage and current are limited. This amplifier will operate to (and below) the lowest expected voltage made available by a typical PCMCIA slot in a laptop PC, and will maintain required linearity at decreased supply voltages.

The RF5300 requires only a single positive supply of 3.0V nominal (or greater) to operate to full specifications. Power control is provided through two bias control input pins (VREG1, VREG2, and VREG3), but in most applications these are tied together and used as a single control input.

There is no external matching required on the input and output of the part, thus allowing minimal bill of material (BOM) parts count in end applications. Both the input and the output of the device are DC-blocked.

For best results, the PA circuit layout from the evaluation board should be copied as closely as possible, particularly the ground layout and ground vias. Other configurations may also work, but the design process is much easier and quicker if the layout is copied from the RF5300 evaluation board. Gerber files of our designs are available on request.

The RF5300 is not a difficult part to implement, but care in circuit layout and component selection is always advisable when designing circuits to operate at 5GHz.

It is important to isolate VCC1 from other RF and low-frequency bypass capacitors on this supply line. This can be accomplished using a suitably-long transmission line which is RF shorted on the other end as described above. Ideally the length of this line will be a quarter wavelength, but it only needs to be long enough so that the effects of other supply bypass capacitors on the VCC1 line are minimized. If board space is a concern, this isolation can also be accomplished with an RF choke inductor or ferrite bead.

The RF5300 has primarily been characterized with a voltage on VREG1, VREG2, and VREG3 of  $2.8V_{DC}$ . However, the RF5300 will operate from a wide range of control voltages. If you prefer to use a control voltage that is significantly different than  $2.8V_{DC}$ , contact RFMD Sales or Applications Engineering for additional data and guidance.

## Evaluation Board Schematic

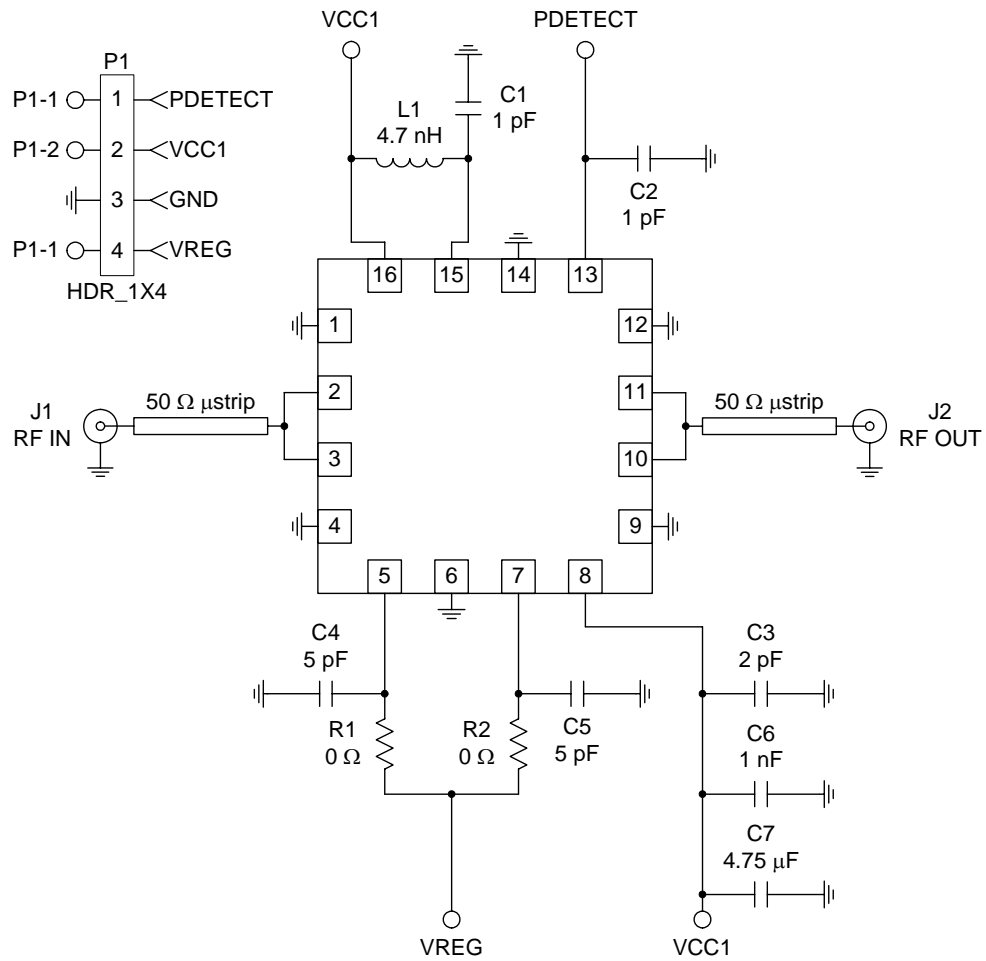

# RF5300

## Evaluation Board Layout Board Size 1.2" x 1.2"

Board Thickness 0.032", Board Material FR-4, Multi-Layer

