

VFT5 Series Surface Mount UHF VCXO

COOL...TO THE TOUCH

Product Data Sheet

Features

- Small, Low Profile SMD Package
- Very Low Phase Jitter and Phase Noise
- Excellent Frequency Stability
- Low Aging, Vacuum sealed Crystal
- Complementary Output Standard
- Enable/Disable Standard
- Very High Frequency
- Available as a CLOCK, add "C" to part #



Applications

- Optical Networking, SONET/SDH
- 10 Gbit Ethernet
- Frequency Translation

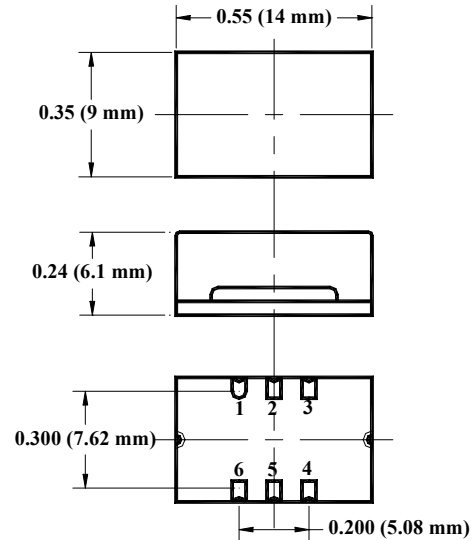
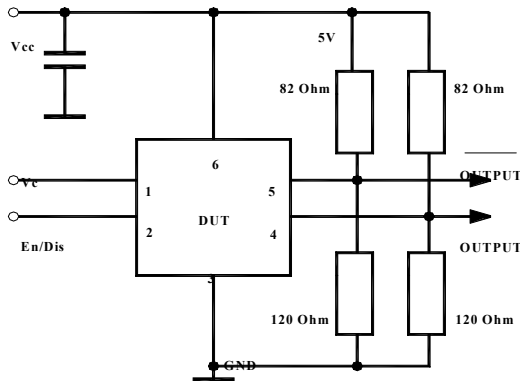

Creating a Part Number



C for clock

Supply Voltage

Code	Specification
S	5V ±5%
L	3.3V ±5%

Temperature Range

Code	Specification
A	-10°C to 60°C
B	0°C to 70°C
C	-40°C to 85°C

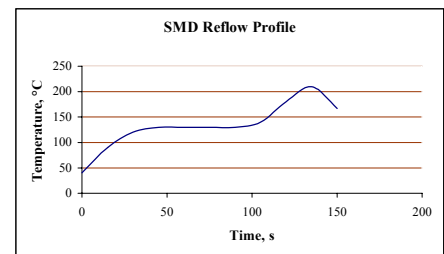

VFT5 Series Surface Mount UHF VCXO

Specifications

Parameter	Symb	Condition	Min	Typ	Max	Unit	Note
-----------	------	-----------	-----	-----	-----	------	------

Absolute Maximum Ratings

Input Break Down Voltage	Vcc		-0.5		7.0	V	
Storage temp.	Ts		-55		85	°C	
Contr. Voltage	Vc		-1		9	V	

Electrical

Frequency range	F		600		960	MHz		
Input Voltage	Vcc		4.75 3.15	5.00 3.30	5.25 3.45	V	Std LV	
Input Current	Icc	50 Ohm Load			75	mA		
Frequency Stability	$\Delta F/F$	vs. Temperature vs. Vcc aging		± 20 ± 5 ± 5		ppm ppm/V ppm/year	First Year	
Load		50 Ohm to Vcc-2V or Thevenin Equiv. Bias Required						
Duty cycle		@50%	45	50	55	%		
Rise/Fall time	Tr/Tf	20 to 80 %			0.6	ns		
Logic "1" level	Voh		Vcc-0.96		Vcc-0.81	V		
Logic "0" level	Vol		Vcc-1.85		Vcc-1.65	V		
Start up time	Ts			2	10	ms		
Phase jitter		1 σ			1	ps	fj>1KHz, also valid for 50 KHz to 80 Mhz	
SSB Phase Noise		@100 Hz @1 KHz @10 KHz @100 KHz		-85 -115 -125 -135		dBc/Hz		
Modulation BW	fm	@Vc=2.5V		>10KHz			@-3db	
Input Impedance		fm < 10KHz		> 50Kohm				
Control voltage	Vc		0 0		5 3.3	V	Std LV	
Deviation		Vc=0V to 5V,25°C Vc=0V to 3.3V,25°C	± 100			ppm		
Absolute usable pull range		Over all	± 50			ppm	1	
Deviation slope		Monotonic, positive		50		ppm/V		
Linearity			-10		+10	%		
Setability (Vc for center freq.)	Vc0	@25°C, Fnom.	2.0 1.25	2.5 1.65	3.0 2.05	V	Std LV	
Enable/disable Function		Input HIGH (>2.5V): Input LOW (<0.5V) or floating:	DISABLED ACTIVE					
Enable/disable Time	Te/Td				100	ns		

Environmental and Mechanical

Operating temp. range	0°C to 70°C (-40°C to 85°C available)
Mechanical Shock	Per MIL-STD-202, Method 213, Cond. E
Thermal Shock	Per MIL-STD-883, Method 1011, Cond. A
Vibration	Per MIL-STD-883, Method 2007, Cond. A
Soldering Conditions	230°C for 90s Max
Hermetic Seal	Leak rate less than 5×10^{-8} atm.cc/s of helium (crystal only)

Electrical Connections

Pin Out	Pin #1 - Voltage Control Pin #3 - Case, Gnd Pin #5 - Complementary Output	Pin #2 - Negative Enable (internal pulldown) Pin #4 - Output Pin #6 - Vcc
---------	---	---

Notes: 1. Up to 100 ppm available at Vcc = 5V