

Typical Applications

- Two-Way Pagers
- 915MHz ISM Band Equipment
- Spread-Spectrum Systems
- 3V AMPS/ETACS Cellular Handsets
- CDPD Portable Data Cards
- Personal Digital Cellular

Product Description

The RF2119 is a high-power, high-efficiency amplifier IC targeting 2V to 4V handheld systems. The device is manufactured on an advanced Gallium Arsenide Heterojunction Bipolar Transistor (HBT) process, and has been designed for use as the final RF amplifier in hand-held digital cellular equipment, spread spectrum systems, and other applications in the 800MHz to 960MHz band. The device is well suited for either CW or pulsed applications. At 3V, the RF2119 can deliver 29.5dBm of linear output power. The device is self-contained with 50Ω input and the output can be easily matched to obtain optimum power, efficiency, and linearity characteristics. The package is a PSSOP-16 with backside ground.

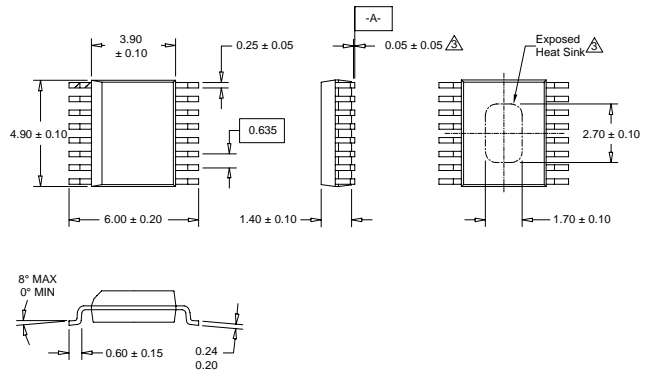

Optimum Technology Matching® Applied

- Si BJT GaAs HBT GaAs MESFET
 Si Bi-CMOS SiGe HBT Si CMOS

Package Style: PSSOP-16

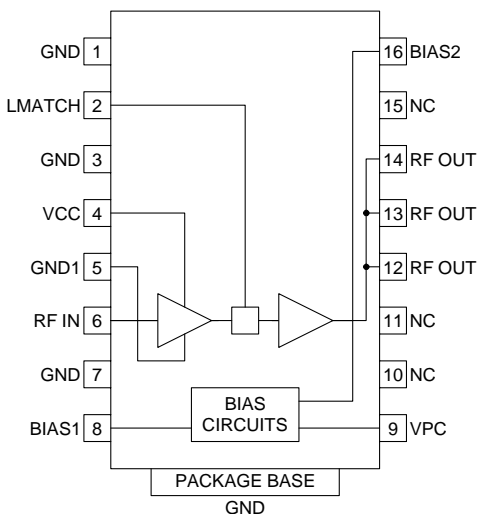

Functional Block Diagram

Features

- Single 2V to 5V Supply
- 30dBm Output Power at 2.5V
- 30dB Small Signal Gain
- 53% Efficiency
- On-board Power Down Mode
- 800MHz to 960MHz Operation

Ordering Information

- RF2119 High Efficiency 2V Power Amplifier
 RF2119 PCBA Fully Assembled Evaluation Board

RF Micro Devices, Inc.
 7628 Thorndike Road
 Greensboro, NC 27409, USA

Tel (336) 664 1233
 Fax (336) 664 0454
<http://www.rfmd.com>

Absolute Maximum Ratings

Parameter	Rating	Unit
Supply Voltage (RF off)	+8.0	V _{DC}
Supply Voltage	+5.2	V _{DC}
Control Voltage (V _{PC})	+3.0	V _{DC}
Input RF Power	+12	dBm
CW Dissipated Power	1.8	W
Peak Dissipated Power	2.5	W
Operating Case Temperature	-30 to +110	°C
Storage Temperature	-30 to +150	°C

Refer to "Handling of PSOP and PSSOP Products" on page 16-15 for special handling information.



Caution! ESD sensitive device.

RF Micro Devices believes the furnished information is correct and accurate at the time of this printing. However, RF Micro Devices reserves the right to make changes to its products without notice. RF Micro Devices does not assume responsibility for the use of the described product(s).

Parameter	Specification			Unit	Condition
	Min.	Typ.	Max.		
Overall					T=25°C, V _{CC} =2.5V, V _{PC} =2.2V, Freq=902MHz, P _{IN} =2dBm
Usable Frequency Range	800	902	960	MHz	
Small Signal Gain		30		dB	
Maximum CW Output Power	29.5	30.5	31.5	dBm	Supply Voltage=2.5V
	31	32	34	dBm	Supply Voltage=3.0V
	32.5	33.5	35	dBm	Supply Voltage=3.5V
		29.3		dBm	Supply Voltage=2.0V
Maximum Pulsed Output Power	30	31	32		Supply Voltage=2.5V, 12.5% duty cycle
	31.5	33	34.5		Supply Voltage=3.0V, 12.5% duty cycle
	33	34	35.5		Supply Voltage=3.5V, 12.5% duty cycle
Total CW Efficiency	45	51		%	
Pulsed Efficiency	47	53		%	12.5% duty cycle
Input Power	0	+2	+6	dBm	
OFF Isolation		-25		dBm	V _{PC} =0V, Input Power=+6dBm
Second Harmonic Suppression		45		dBc	
Third Harmonic Suppression		>60		dBc	
Input VSWR			<2:1		With a 50Ω source impedance
Output Load VSWR	10:1				No damage.
AMPS Application #1					T=25°C, V _{CC} =3.4V, V _{PC} =1.8V, Freq=836MHz, P _{IN} =+3dBm
Frequency		824 to 849		MHz	
Maximum Output Power	30.5			dBm	
Efficiency @ Maximum Output Power		50		%	
Idle Current		195	250	mA	
Second Harmonic Suppression		-45		dBc	
Current Total		760		mA	
AMPS Application #2					T=25°C, V _{CC} =3.5V, V _{PC} =1.6V, Freq=836MHz, P _{IN} =+8dBm (see AMPS application schematic)
Frequency		824 to 849		MHz	
Maximum Output Power	29.5	30.5		dBm	V _{CC} =2.7V
	30.8	31.5		dBm	V _{CC} =3.0V
	32	33		dBm	V _{CC} =3.5V
Efficiency @ Maximum Output Power	50	55		%	
Idle Current		120		mA	
I _{PC} @ Maximum Output Power		20		mA	

Parameter	Specification			Unit	Condition
	Min.	Typ.	Max.		
Power Down Control					
Turn On/Off Time			100	ns	
V _{PC} "OFF" Voltage	0.2	0.5		V	
V _{PC} "ON" Voltage	2.0	2.2	2.8	V	
I _{PC} "ON" Current		30		mA	V _{PC} =2.2V
I _{PC} "OFF" Current			10	μA	Standby, V _{PC} =0.5V
Power Supply					
Voltage		2.5		V	Specifications
Voltage	2.0		5.0	V	Operating Limits
Current Total	700	900	1200	mA	V _{CC} =2.5V, V _{PC} =2.2V, P _{IN} =+3dBm, T=25°C

Pin	Function	Description	Interface Schematic
1	GND	Ground externally.	
2	LMATCH	Interstage tuning. This pin is internally DC blocked and will connect to a shunt inductor or microstrip line used for interstage tuning. Length from pin to via should be approximately 60mils for 915MHz and 75mils for 902MHz and 120mils for 836MHz. The lumped element equivalent is 1.2nH to 2.0nH to ground, depending on frequency band of interest.	
3	GND	Ground externally.	
4	VCC1	Power supply for stage 1. V_{CC} should be fed through a 3.9nH inductor with a decoupling capacitor on the V_{CC} side.	
5	GND1	Ground for stage 1. Keep traces physically short and connect immediately to ground plane for best performance.	
6	RF IN	RF input. An external DC blocking capacitor is required if this port is connected to a DC path to ground or a DC voltage.	
7	GND	Ground externally.	
8	BIAS1	Ground return for the first stage bias. This pin should be connected to a 33nH inductor to ground.	
9	VPC	Power control voltage. For maximum power, this voltage should be at least 2.2V. To turn off, this voltage should be less than 0.6V. This pin should be bypassed as close to the pin as practical.	
10	NC	No connection.	
11	NC	No connection.	
12	RF OUT	RF output and power supply for the output stage. The bias for the output stage is provided through this pin and pin 13. An external matching network is required to provide the optimum load impedance; see the application schematics for details.	
13	RF OUT	Same as pin 12.	
14	RF OUT	Same as pin 12.	
15	NC	No connection.	
16	BIAS2	Ground return for the second stage bias. This pin should be connected to a 33nH inductor to ground.	
Pkg Base	GND	Ground connection. The backside of the package should be soldered to a top side ground pad which is connected to the ground plane with multiple vias. The pad should have a short thermal path to the ground plane.	

Application Schematic
902MHz to 928MHz ($V_{CC}=2.5V$)

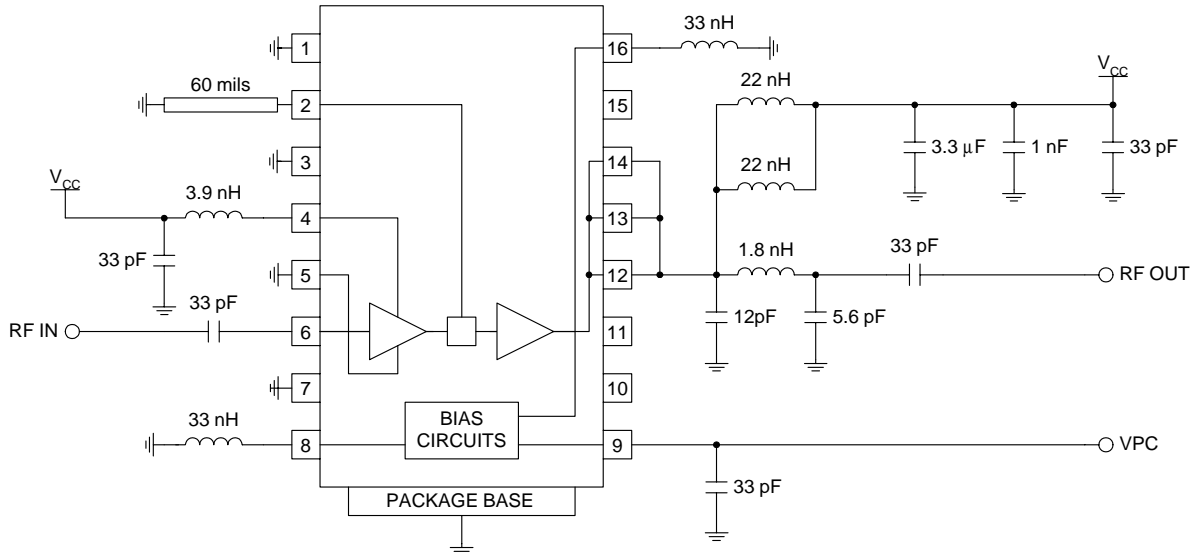

AMPS Application Schematic
824MHz to 849MHz ($V_{CC}=3.5V$)

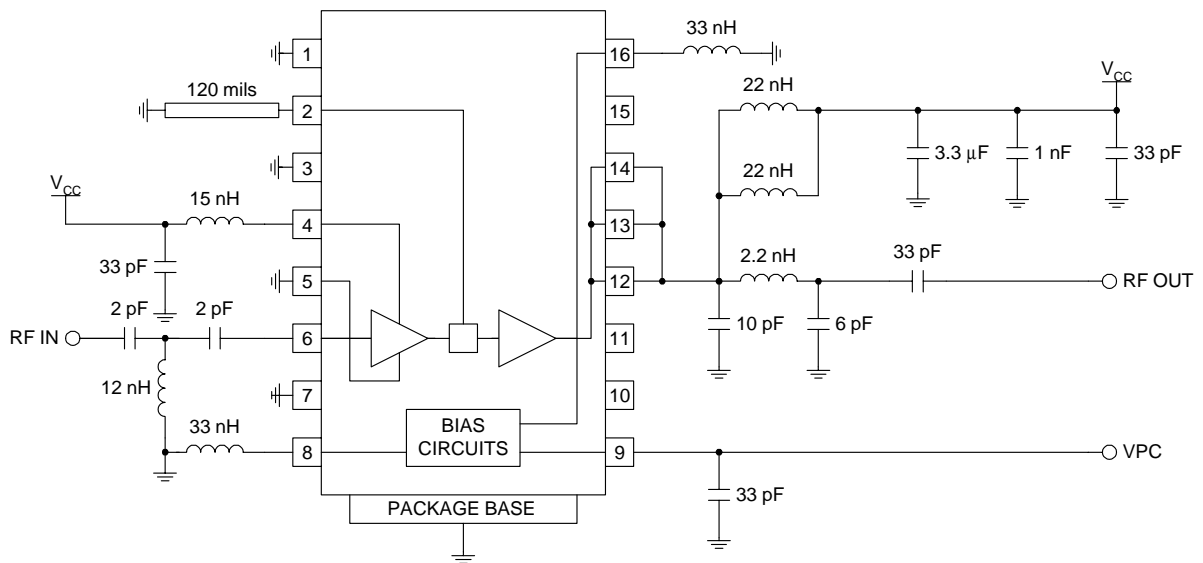

Evaluation Board Schematic 824MHz to 928MHz ($V_{CC} = 3.5V$) (Download [Bill of Materials](http://www.rfmd.com) from www.rfmd.com.)

2

POWER AMPLIFIERS

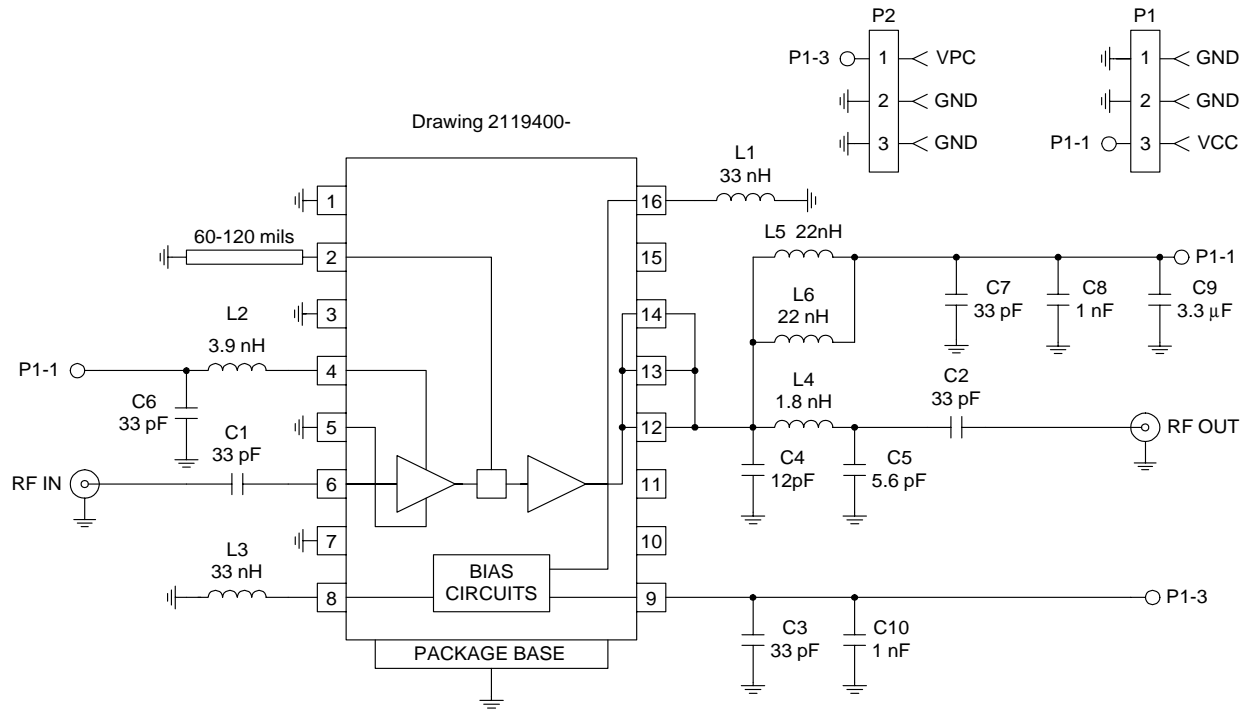

PCB mat'l: FR-4;
Two Layer: (31 mils; w/plating)

Off of Pin 2: 60 mil microstrip line for 902 MHz to 928 MHz and 75 mil microstrip line for 890 MHz to 915 MHz and 120 mil for 824 MHz to 849 MHz. Lumped element off of Pin 2 would be 1.2 nH to 2.0 nH to ground depending on frequency band of interest.

Evaluation Board Layout
1.020" x 1.020"

