

Dual EL Lamp Driver

The IMP522 is a dual-output, high-voltage electroluminescent (EL) lamp driver. Either or both EL lamp driver outputs can be turned ON with the LMPSEL select pin. One EL lamp is connected between V_A and V_{AB} and the other is connected between V_B and V_{AB} . V_{AB} is a common pin for both lamps. With an input supply voltage between 2.0V and 6.5V, the typical regulated lamp drive voltage is 220V peak-to-peak.

The device uses a single inductor and a minimum number of passive components: a storage capacitor, a fast recovery diode and two resistors to set the PWM and EL drive frequencies. These can be independently set to optimize brightness and minimize power consumption. R_{SW} is connected between the R_{SW-OSC} pin and the supply pin V_{DD} to set the frequency for the internal 4.0Ω switching MOSFET. The switch duty cycle is 88%. The EL lamp driver frequency is set by R_{EL} connected between the R_{EL-OSC} pin and the V_{DD} pin.

Designed to minimize battery current drain, the IMP522 draws 2mA maximum. A power-saving shutdown mode reduces current to 2μA maximum.

The IMP522 is available in a compact 10-pin MicroSO package and in die form.

Key Features

- ◆ Drive two EL lamps independently
- ◆ Digital LMPSEL pin
 - Activate either or both EL output drivers
- ◆ 220V_{p-p} typical AC output voltage drives 30nF EL lamps
- ◆ Wide operating voltage range: 2V to 6.5V
- ◆ Low current consumption: 2mA maximum
- ◆ Disable mode extends battery life
 - Disable current 2μA maximum
- ◆ Compact 10-pin MicroSO package
- ◆ High-voltage, low-cost CMOS process

Applications

- ◆ Cellular phones
- ◆ PDAs/Handheld computers
- ◆ Toys/Consumer electronics
- ◆ Safety Illumination
- ◆ LCD modules
- ◆ Remote controls

Block Diagram

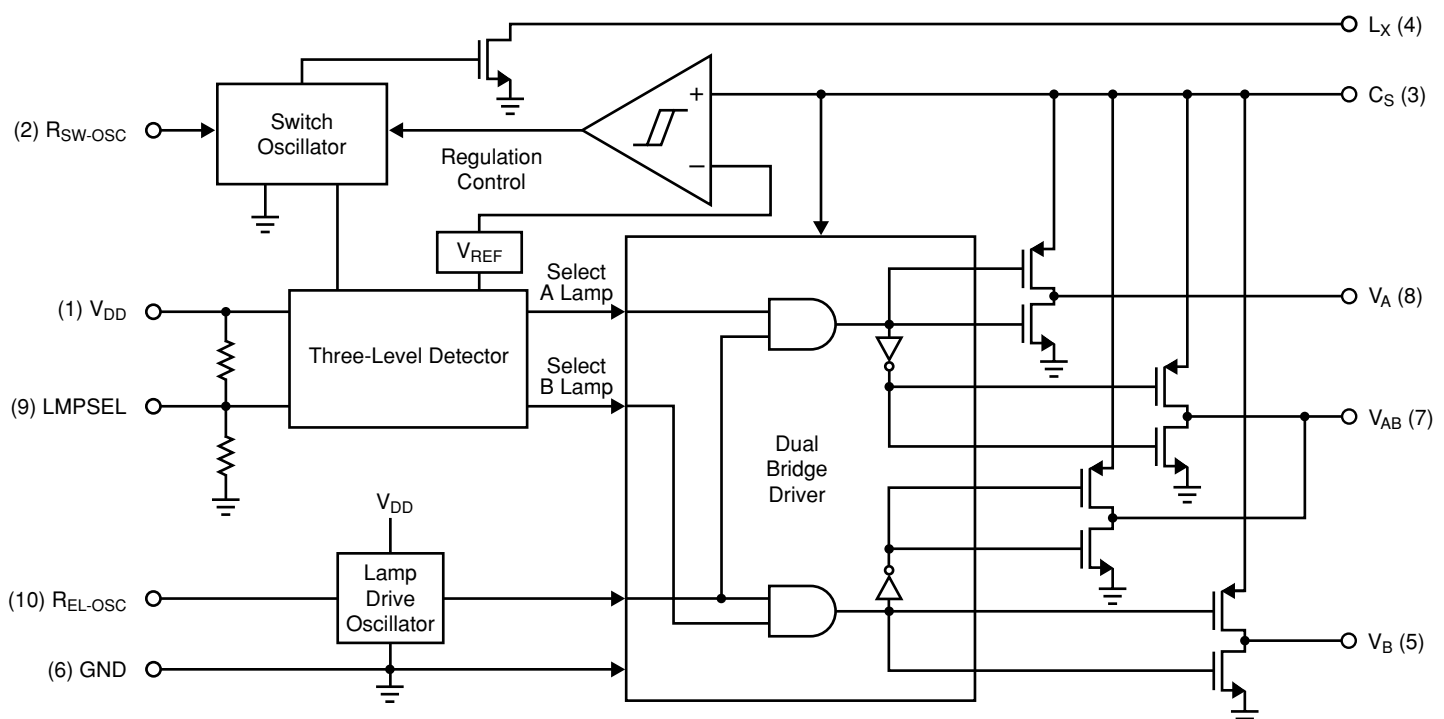

522_01.eps

Pin Configuration

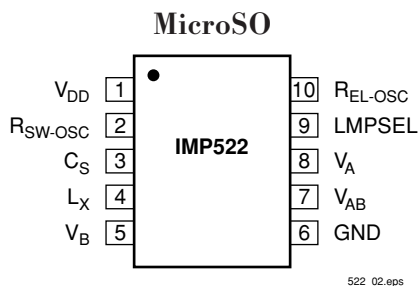

Ordering Information

Part Number	Input Voltage	Temperature Range	Pins-Package
IMP522EMB	2.0V to 6.5V	-40°C to +85°C	10-MicroSO

Add /T to ordering part number for Tape and Reel.

Absolute Maximum Ratings

V_{DD} , R_{SW-OSC} and R_{EL-OSC}	-0.5V to +7.0V
C_S , L_X	-0.5V to +120V
Operating Temperature Range	-40°C to +85°C
Storage Temperature Range	-65°C to +150°C
Power Dissipation (MicroSO)	500mW
V_A , V_B , V_{AB}	-0.5V to V_{CS} (pin 3)

Note: All voltages are referenced to GND.

These are stress ratings only and functional operation is not implied. Exposure to absolute maximum ratings for prolonged time periods may affect device reliability.

Electrical Characteristics

Unless otherwise noted, $V_{DD} = 3.0V$, $R_{SW} = 910k\Omega$, $R_{EL} = 2.7M\Omega$, $L = 220\mu H$ and $T_A = 25^\circ C$.

Parameter	Symbol	Conditions	Min	Typ	Max	Units
ON-resistance of MOS Switch	$R_{DS(ON)}$	$I = 100mA$		4.0	8.0	Ω
Output Voltage Regulation	V_{CS}	$V_{DD} = 2.0$ to $6.5V$, $T = -40^\circ C$ to $85^\circ C$		110	120	V
Output Voltage Peak-to-Peak (in regulation)	$V_A - V_{AB}$, $V_B - V_{AB}$	In Regulation		220		V
Input Current at V_{DD} Pin	I_{DD}	LMPSEL = GND		650		μA
Powerdown Input Current	I_{DDQ}	$V_{RSW-OSC} < 100mA$ $V_{DD} = 2.0$ to 6.5 $T = -40^\circ C$ to $85^\circ C$			2	μA
Input Current Plus Inductor Current	I_{IN}	See Figure 1 LMPSEL = GND or V_{DD} LMPSEL = floating		30 43		mA mA
Output Drive Frequency	f_{EL}	See Figure 1		250		Hz
Switching Frequency	f_{SW}	See Figure 1		61		kHz
Switching Duty Cycle	D_{SW}	See Figure 1		88		%
LMPSEL Low-Level Threshold	V_{IL}			$0.3 V_{DD}$		V
LMPSEL High-Level Threshold	V_{IH}			$0.7 V_{DD}$		V
LMPSEL Input Resistance	R_{LMPSEL}			50		$k\Omega$
LMPSEL Sink/Source Resistance	I_{LMPSEL}	Floating/High Impedance State	± 5			μA
LMPSEL Hysteresis	V_{hys}			50		mV

Pin Descriptions

Pin Number	Name	Function
1	V_{DD}	Positive voltage supply. Inductor L may be connected here or to a separate unregulated supply.
2	R_{SW-OSC}	Switch-mode resistor pin. The external resistor R_{SW} determines switching frequency.
3	C_S	Boost converter storage capacitor. The voltage across the EL lamp is approximately equal to twice the voltage at C_S .
4	L_X	Connection to flyback inductor L.
5	V_B	Output for EL Lamp B.
6	GND	Ground.
7	V_{AB}	Common terminal for both EL lamps.
8	V_A	Output for EL Lamp A.
9	LMPSEL	Digital three-state input pin. Select either lamp A or lamp B or both lamps.
10	R_{EL-OSC}	The EL lamp oscillator frequency setting pin. External resistor R_{EL} connected to V_{DD} sets the EL Lamp drive frequency for both lamps.

522_I01.eps

Application Information

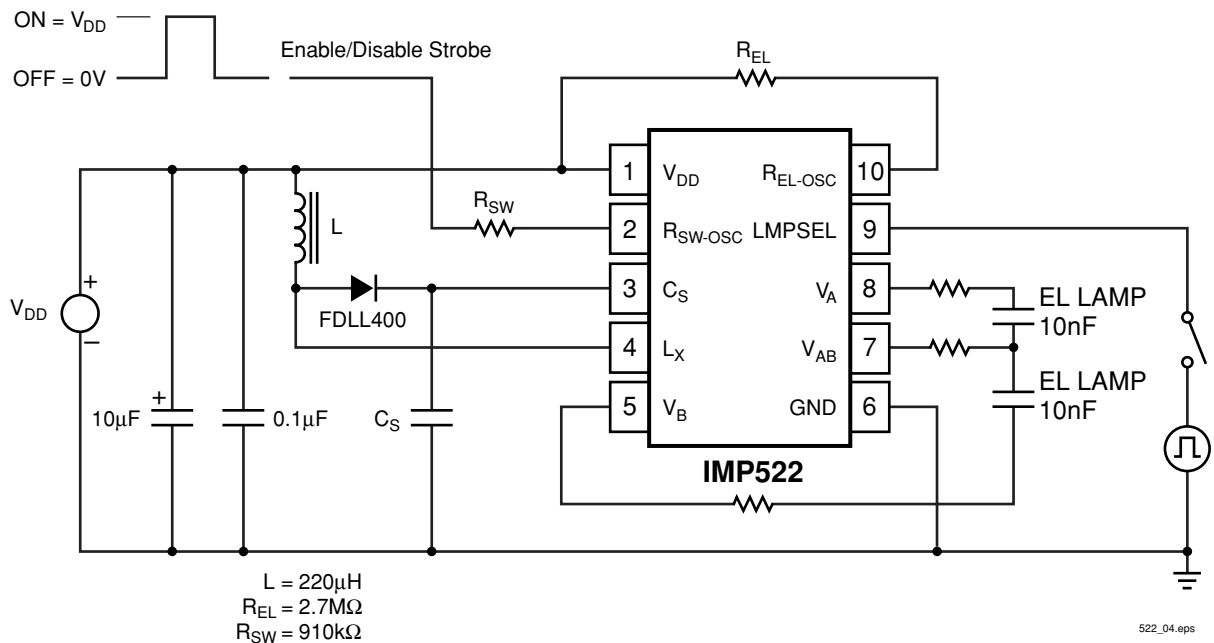

Figure 1. Test Circuit

Application Information

EL Lamp Drive

The outputs $V_A - V_{AB}$ and $V_B - V_{AB}$ are configured as H-bridges, driven by the EL oscillator. Each output is switched between C_S and ground on alternate phases, creating peak-to-peak signals across the EL lamps of twice the regulated voltage.

EL Lamp Selection: LMPSEL

The digital input pin LMPSEL allows either or both EL lamps to be active. Lamp A is active when LMPSEL is LOW and lamp B is active when LMPSEL is HIGH. When LMPSEL is left floating or driven by a three-state driver in the high impedance state, both lamp driver outputs are active.

LMPSEL Signal	Lamp A Drive V_A and V_{AB}	Lamp B Drive V_B and V_{AB}
HIGH	OFF	ON
LOW	ON	OFF
Floating/ High Impedance	ON	ON

522_102.eps

The logic HIGH signal level is defined as greater than $0.7V_{DD}$ and logic LOW is defined as less than $0.3V_{DD}$. A floating level is recognized with the signal level between $0.3V_{DD}$ and $0.7V_{DD}$, or when the output impedance of the driving voltage signal source is infinite (driver in OFF state).

Both drivers are OFF if the IMP522 is disabled.

EL Driver Output Overvoltage Regulator

The IMP522 maximum V_{C_S} output voltage is between 110V and 120V. The internal overvoltage regulator skips the inductor switching whenever the voltage on the C_S pin exceeds the regulation threshold. The internal overvoltage detection trip point has a hysteresis of 1V and a range of 110V to 120V at room temperature.

PWM Circuit Switching

The switching MOSFET is driven by the PWM signal (nominally 61kHz). During the first 88% of the period, the switch is ON, providing a low impedance path ($<8\Omega$) from L_X to ground. This causes the external inductor to charge. In the last 12% of the period, the MOSFET is turned OFF. This causes the voltage on the output of L_X to rise up to a high value. At some point, this will forward-bias the external diode, thus pumping charge into the storage capacitor C_S . The voltage on C_S increases each cycle to between 110V and 120V. When the internal regulation trip-point is reached, the overvoltage regulator turns the MOSFET switch OFF to conserve power.

Application Information

Power Sequencing

To power up the chip, the R_{SW-OSC} pin is connected to V_{DD} through the external R_{SW} resistor. The voltage on the pin will charge up to $V_{DD}/2$. An internal threshold detector circuit monitors the pin voltage and when it exceeds the threshold range (0.2V to 0.9V) it powers up the oscillator and internal bias modules. This starts a delay counter which is one half of the EL oscillator period, after which power to the high voltage internal modules is applied. The IMP522 is then operating fully.

To power down the chip, R_{SW} is driven to ground via a switch or logic gate. When the voltage on the driver side of the resistor falls below $V_{DD}/2$, there will be no input bias current into the R_{SW-OSC} pin. This immediately powers down the internal high-voltage circuits, which effectively shuts the lamp off. At this point the oscillator and bias modules still draw quiescent current, but oscillations have ceased. As the R_{SW-OSC} pin voltage falls below 0.1, the oscillator and bias modules are also fully powered down.

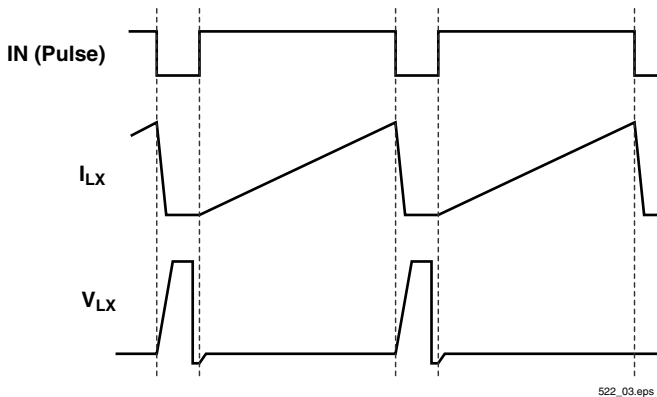

Figure 1. Driver Waveforms

Power Saving Disable Mode

The IMP522 can be powered up and down with R_{SW-OSC} . In normal operation, this resistor on the R_{SW-OSC} pin is connected to V_{DD} or another voltage source. To power down (disable) the IMP522, R_{SW} is connected to ground.

When disabled, the IMP522 quiescent current drops to typically 20nA.

In die form, an extra pin \overline{ENABLE} is available (contact factory). Connecting this pad to V_{DD} disables the chip. The \overline{ENABLE} signal can be driven by a microcontroller.

Oscillator Frequency Adjustment

The EL lamp drive and PWM boost converter oscillation frequencies can be programmed independently.

The R_{SW} resistor, connected between the R_{SW-OSC} pin and V_{DD} , determines the Inductor Switching (or PWM-) frequency. For the recommended nominal resistor value of 910k Ω , the frequency is 61kHz. For other resistor values, the frequency is inversely proportional to the resistor value. Increasing the resistance will lower the frequency.

The R_{EL} resistor, connected between the R_{EL-OSC} pin and V_{DD} , determines the EL lamp drive frequency. For the recommended nominal resistor value of 2.7M Ω , the frequency is 250Hz. For other resistor values, the frequency is inversely proportional to the resistor value: increasing the resistance will lower the frequency.

Oscillator	Nominal Resistor	Nominal Frequency
EL Lamp Drive	$R_{EL} = 2.7M\Omega$	250Hz
Inductor Switch (PWM)	$R_{SW} = 910k\Omega$	61kHz

522_103.eps

Package Dimensions

MicroSO (10-Pin)

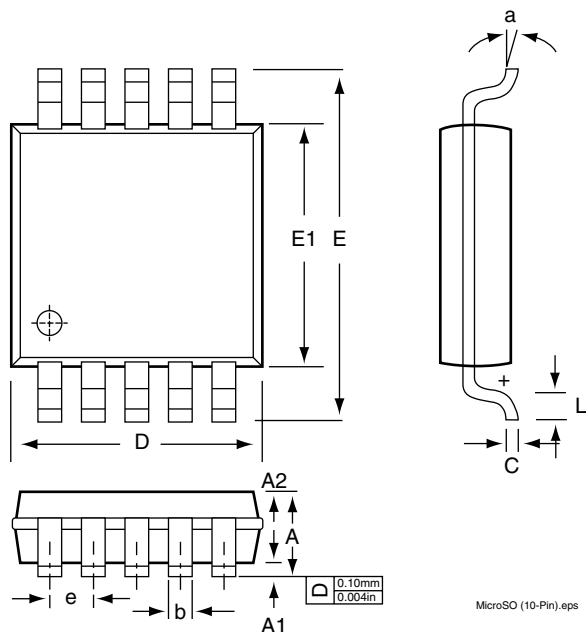

	Inches		Millimeters	
	Min	Max	Min	Max
MicroSO (10-Pin)				
A	—	0.0433	—	1.10
A1	0.0020	0.0059	0.050	0.15
A2	0.0307	0.0370	0.78	0.94
b	0.0059	0.0098	0.15	0.25
C	0.0051	0.0091	0.13	0.23
D	0.1142	0.1220	2.90	3.10
e	0.0197 BSC		0.50 BSC	
E	0.1990	0.1871	5.05	5.05
E1	0.1142	0.1220	2.90	3.10
L	0.0157	0.0276	0.40	0.70
a	0°	6°	0°	6°

522_104.at3

Thermal Resistance

θ_{JC}	41°C/W
θ_{JA}	113°C/W

522_105.at3



ISO 9001 Registered

IMP, Inc.
 Corporate Headquarters
 2830 N. First Street
 San Jose, CA 95134-2071
 Tel: 408-432-9100
 Fax: 408-434-0335
 e-mail: info@impinc.com
<http://www.impweb.com>

The IMP logo is a registered trademark of IMP, Inc.
 All other company and product names are trademarks of their respective owners.

© 2001 IMP, Inc.
 Printed in USA
 Publication #: 2007
 Revision: E
 Issue Date: 03/16/01
 Type: Advance Info