

POWER MANAGEMENT

Low Power, 5V/3.0V μ P Reset

- Active LOW, Open-Drain Output
- 350ms Reset Period

The IMP1233M supply voltage monitor is an improved, low-power replacement for the Dallas Semiconductor DS1233M. Maximum supply current over temperature is a low 20 μ A, representing 60 percent lower power as compared to the DS1233M.

The IMP1233M issues an active LOW reset signal whenever the monitored supply is out-of-tolerance. A precision reference and comparator circuit monitor power supply (V_{CC}) level. Tolerance level options are 5- and 10-percent for a 5V power supply. The tolerance is 15-percent for the 3.3V, IMP1233M. When an out-of-tolerance condition is detected, an internal power-fail signal is generated which forces an active LOW reset signal. After V_{CC} returns to an in-tolerance condition, the reset signal remains active for 350ms to allow the power supply and system microprocessor to stabilize.

The IMP1233M is designed with an open-drain output stage and operates over the extended industrial temperature range. Devices are available in the compact surface mount SO-8 package.

Other low power products in this family include the IMP1810/11/12/15/16/17 and IMP1233D.

Key Features

- ◆ Improved Dallas DS1233M replacement
 - 60% lower maximum supply current
- ◆ Low Supply Current
 - 20 μ A maximum (5.5V)
 - 15 μ A maximum (3.6V)
- ◆ Automatically restarts a microprocessor after power failure
- ◆ 350ms reset delay after V_{CC} returns to an in-tolerance condition
- ◆ Active LOW power-up reset, 5k Ω internal pull-up
- ◆ Precision temperature-compensated voltage reference and comparator
- ◆ Eliminates external components
- ◆ Pin function compatible with the Motorola MC33064, MC34064, MC33164 and MC34164
- ◆ Motorola 68xxx and HC16 compatible
- ◆ Compact surface mount SO-8 package
- ◆ Operating temperature –40°C to +85°C

Family Selection Guide

Part	RESET Voltage (V)	RESET Time (ms)	Output Stage	RESET Polarity
IMP1810	4.620, 4.370, 4.120	150	Push-Pull	LOW
IMP1811	4.620, 4.350, 4.130	150	Open-Drain	LOW
IMP1812	4.620, 4.350, 4.130	150	Push-Pull	HIGH
IMP1815	3.060, 2.880, 2.550	150	Push-Pull	LOW
IMP1816	3.060, 2.880, 2.550	150	Open-Drain	LOW
IMP1817	3.060, 2.880, 2.550	150	Push-Pull	HIGH
IMP1233D	4.625, 4.375, 4.125	350	Open-Drain	LOW
IMP1233M	4.625, 4.375, 2.720	350	Open-Drain	LOW

Applications

- ◆ Set-top boxes
- ◆ Cellular phones
- ◆ PDAs
- ◆ Energy management systems
- ◆ Embedded control systems
- ◆ Printers
- ◆ Single board computers

Block Diagram

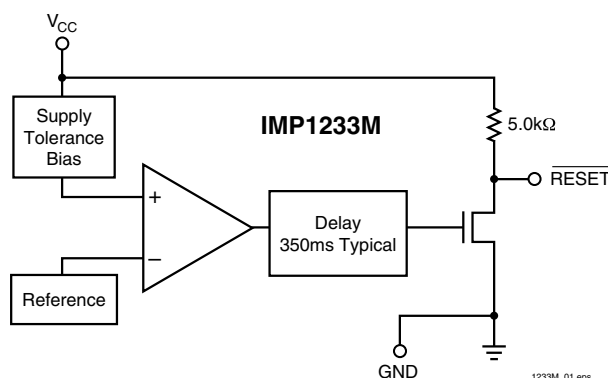

Typical Application

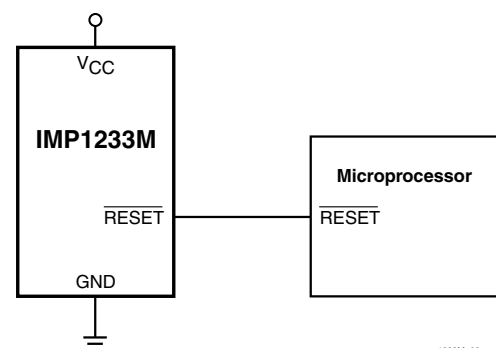

Pin Configuration

SO-8

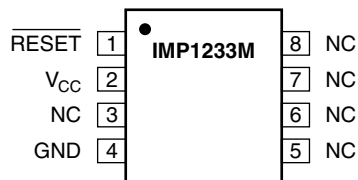

1233M_03.eps

Pin Descriptions

Pin Numbers		Name	Function
SO-8	TO-92		
1	1	RESET	Active LOW reset output
2	2	V _{CC}	Power supply input
3, 5, 6, 7 and 8	—	NC	No connection
4	3	GND	Ground

Ordering Information

Device Summary							
Part** Number	RESET Output Voltage (V)	RESET Tolerance (%)	RESET Time (ms)	Output Stage		SO-8 Package	RESET Polarity
				Open-Drain*	Push-Pull		
IMP1233MS-55/T	4.625	5	350	●		●	LOW
IMP1233MS-5/T	4.375	10	350	●		●	LOW
IMP1233MS-3/T	2.720	15	350	●		●	LOW

* Internal 5kΩ resistor pull up.

** /T indicates Tape and Reel.

1233M_103.eps

Absolute Maximum Ratings

Voltage on V_{CC} -0.5V to 6.5V
 Voltage on \overline{RESET} -0.5V to $V_{CC} + 0.5V$
 Operating Temperature Range -40°C to 85°C

Soldering Temperature 260°C for 10 seconds
 Storage Temperature -55°C to 125°C

Voltages measured with respect to ground.

These are stress ratings only and functional operation is not implied.

Electrical Characteristics

Unless otherwise noted, $V_{CC} = 1.2V$ to $5.5V$ and specifications are over the operating temperature range of -40°C to +85°C.
 All voltages are referenced to ground.

Parameter	Symbol	Conditions	Min	Typ	Max	Units
Supply Voltage	V_{CC}		1.2		5.5	V
Output Voltage	V_{OH}	$I_{OUT} < 500\mu A$	$V_{CC} - 0.5V$	$V_{CC} - 0.1V$		V
Output Current	I_{OL}	Output = 0.4V, $V_{CC} \geq 2.7V$	+8			mA
Operating Current	I_{CC}	$V_{CC} < 5.5V$, \overline{RESET} output open		8	20	μA
Operating Current	I_{CC}	$V_{CC} \leq 3.6V$, \overline{RESET} output open		6	15	μA
V_{CC} Trip Point (IMP1233M-5)	V_{CCTP}		4.25	4.375	4.49	V
V_{CC} Trip Point (IMP1233M-55)	V_{CCTP}		4.5	4.625	4.75	V
V_{CC} Trip Point (IMP1233M-3)	V_{CCTP}		2.64	2.72	2.8	V
Voltage High Trip Level IMP1233M-5 IMP1233M-55	V_{HTL}				4.75	V
Voltage Low Trip Level IMP1233M-5 IMP1233M-55	V_{LTL}				4.00	V
Voltage High Trip Level IMP1233M-3	V_{HTL}				3.14	V
Voltage Low Trip Level IMP1233M-3	V_{LTL}				2.48	V
Internal Pull-Up Resistor	R_P		3.5	5.0	7.5	k Ω
Output Capacitance	C_{OUT}				10	pF
V_{CC} Detect to \overline{RESET} Low	t_{RPD}			2	10	μs
V_{CC} Slew Rate ($V_{HTL} - V_{LTL}$)	t_F		300			μs
V_{CC} Slew Rate ($V_{LTL} - V_{HTL}$)	t_R		0			ns
V_{CC} Detect to \overline{RESET} High	t_{RPU}	$t_R = 5\mu s$	200	350	500	ms

Notes: 1. A 1k Ω external resistor maybe required in some applications for proper operation of the microprocessor reset control circuit.

Application Information

Operation – Power Monitor

The IMP1233M detects out-of-tolerance power supply conditions. It resets a processor during power-up and issues a reset to the system processor when the monitored power supply voltage is below the reset threshold (power-down). When an out-of-tolerance V_{CC} voltage is detected, the $\overline{\text{RESET}}$ signal is asserted. On power-up, $\overline{\text{RESET}}$ is kept active (LOW) for approximately 350ms after the power supply voltage has reached the selected tolerance. This allows the power supply and microprocessor to stabilize before $\overline{\text{RESET}}$ is released.

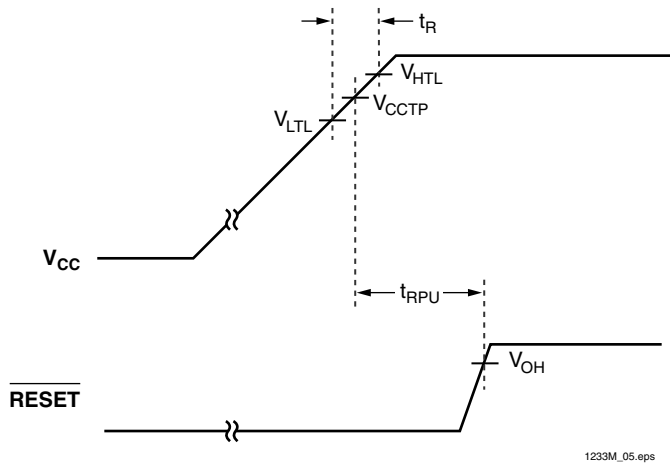

Figure 1. Timing Diagram: Power-Up

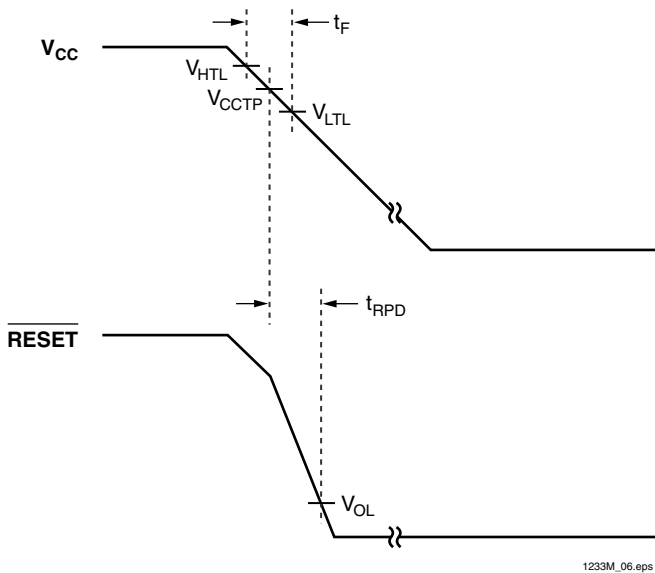
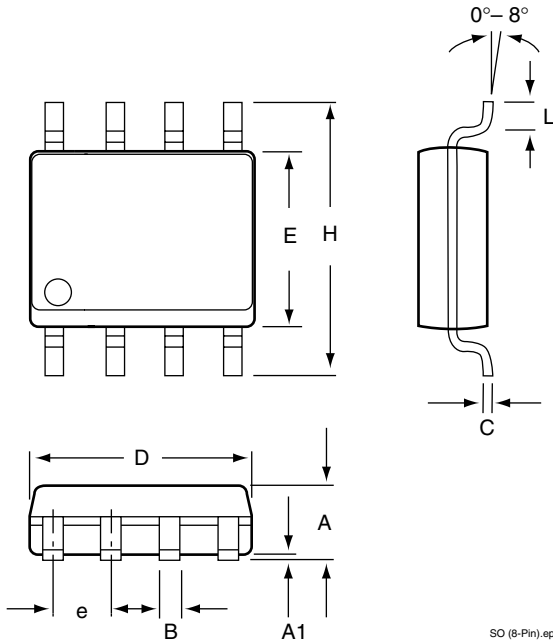

Figure 2. Timing Diagram: Power-Down

Plastic SO-8 (8-Pin)



Absolute Maximum Ratings

	Inches		Millimeters	
	Min	Max	Min	Max
Plastic SO-8 (8-Pin)				
A	0.053	0.069	1.35	1.75
A1	0.004	0.010	0.10	0.25
B	0.013	0.020	0.33	0.51
C	0.007	0.010	0.19	0.25
e	0.050		1.27	
E	0.150	0.157	3.80	4.00
H	0.228	0.244	5.80	6.20
L	0.016	0.050	0.40	1.27
D	0.189	0.197	4.80	2.00

1233M_15.eps



IMP, Inc.
Corporate Headquarters
2830 N. First Street
San Jose, CA 95134-2071
Tel: 408-432-9100
Tel: 800-438-3722
Fax: 408-434-0335
e-mail: info@impinc.com
<http://www.impweb.com>

The IMP logo is a registered trademark of IMP, Inc.
All other company and product names are trademarks of their respective owners.

2000 © IMP, Inc.
Printed in USA
Publication #: 1013
Revision: B
Issue Date: 06/01/00
Type: Preliminary