

FLX207MH-12

X, Ku Band Power GaAs FET

FEATURES

- High Output Power: $P_{1dB} = 32.5\text{dBm(Typ.)}$
- High Gain: $G_{1dB} = 7.0\text{dB(Typ.)}$
- High PAE: $\eta_{add} = 28\%\text{(Typ.)}$
- Proven Reliability
- Hermetic Metal/Ceramic Package

DESCRIPTION

The FLX207MH-12 is a power GaAs FET that is designed for general purpose applications in the X-Band frequency range as it provides superior power, gain, and efficiency.

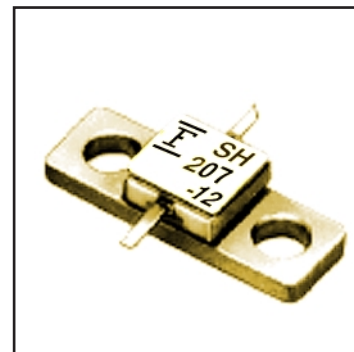

Fujitsu's stringent Quality Assurance Program assures the highest reliability and consistent performance.

ABSOLUTE MAXIMUM RATING (Ambient Temperature $T_a=25^\circ\text{C}$)

Item	Symbol	Condition	Rating	Unit
Drain-Source Voltage	V_{DS}		15	V
Gate-Source Voltage	V_{GS}		-5	V
Total Power Dissipation	P_T	$T_C = 25^\circ\text{C}$	12.5	W
Storage Temperature	T_{stg}		-65 to +175	$^\circ\text{C}$
Channel Temperature	T_{ch}		175	$^\circ\text{C}$

Fujitsu recommends the following conditions for the reliable operation of GaAs FETs:

1. The drain-source operating voltage (V_{DS}) should not exceed 10 volts.
2. The forward and reverse gate currents should not exceed 17.8 and -1.0 mA respectively with gate resistance of 250Ω .
3. The operating channel temperature (T_{ch}) should not exceed 145°C .

ELECTRICAL CHARACTERISTICS (Ambient Temperature $T_a=25^\circ\text{C}$)

Item	Symbol	Test Conditions	Limit			Unit
			Min.	Typ.	Max.	
Saturated Drain Current	I_{DSS}	$V_{DS} = 5\text{V}, V_{GS} = 0\text{V}$	-	800	1200	mA
Transconductance	g_m	$V_{DS} = 5\text{V}, I_{DS} = 500\text{mA}$	-	400	-	mS
Pinch-off Voltage	V_p	$V_{DS} = 5\text{V}, I_{DS} = 40\text{mA}$	-1.0	-2.0	-3.5	V
Gate Source Breakdown Voltage	V_{GSO}	$I_{GS} = -40\mu\text{A}$	-5	-	-	V
Output Power at 1dB G.C.P.	P_{1dB}	$V_{DS} = 10\text{V},$ $I_{DS} = 0.6 I_{DSS} \text{(Typ.)},$ $f = 12.5 \text{GHz}$	31.5	32.5	-	dBm
Power Gain at 1dB G.C.P.	G_{1dB}		6.0	7.0	-	dB
Power-added Efficiency	η_{add}		-	28	-	%
Thermal Resistance	R_{th}	Channel to Case	-	10	12	$^\circ\text{C/W}$

CASE STYLE: MH

G.C.P.: Gain Compression Point

FLX207MH-12

X, Ku Band Power GaAs FET

POWER DERATING CURVE

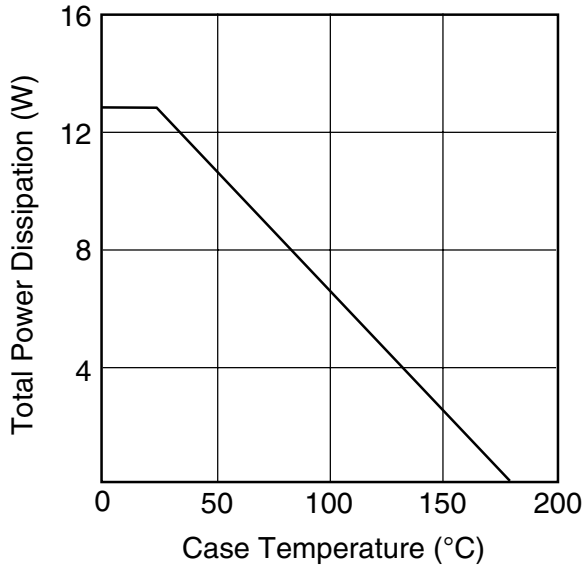

DRAIN CURRENT vs. DRAIN-SOURCE VOLTAGE

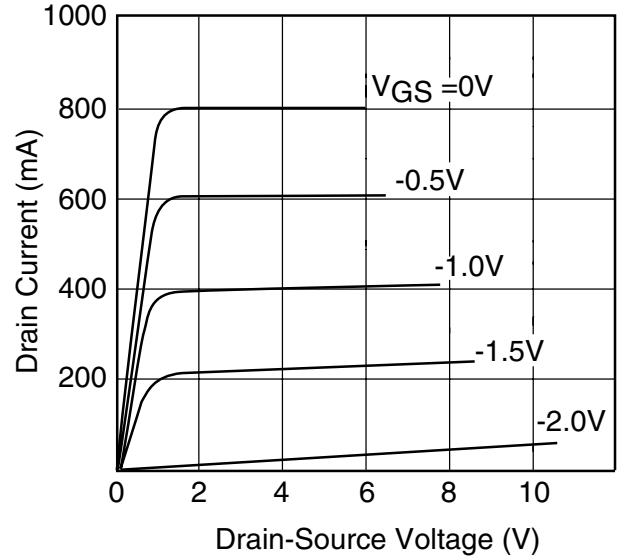

OUTPUT POWER vs. INPUT POWER

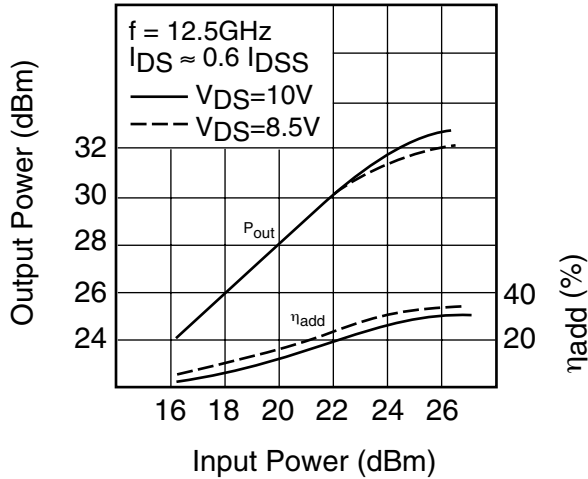

P1dB & η_{add} vs. VDS

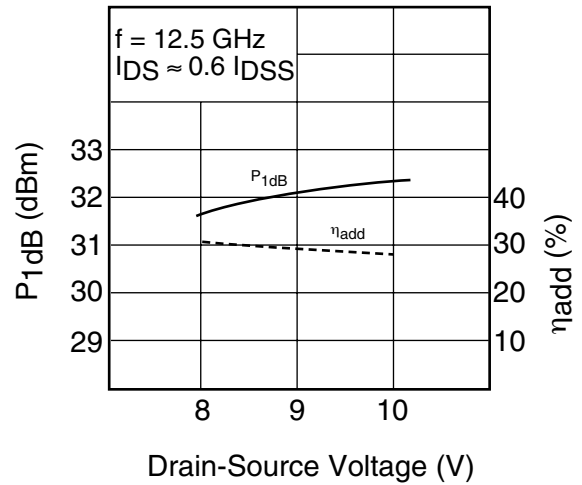

FLX207MH-12

X, Ku Band Power GaAs

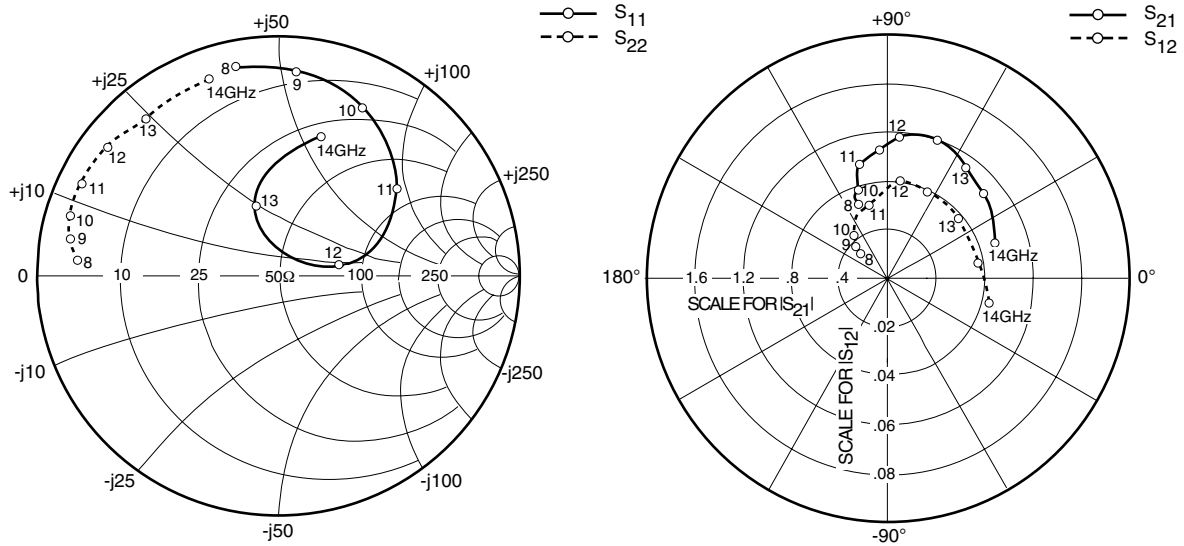

S-PARAMETERS

$V_{DS} = 10V, I_{DS} = 480mA$

FREQUENCY (MHZ)	S11		S21		S12		S22	
	MAG	ANG	MAG	ANG	MAG	ANG	MAG	ANG
500	.954	-136.6	7.426	115.6	.021	33.0	.312	-147.0
1000	.945	-161.8	4.100	105.6	.021	32.1	.363	-147.5
8000	.892	101.8	.684	112.8	.017	138.1	.832	175.4
8500	.877	94.1	.685	114.2	.017	136.1	.857	173.1
9000	.853	85.3	.702	113.2	.019	136.5	.872	170.1
9500	.831	75.3	.735	113.3	.020	128.3	.875	167.3
10000	.778	63.9	.781	109.2	.022	130.8	.898	163.8
10500	.713	51.0	.806	109.0	.030	117.1	.917	159.0
11000	.609	37.1	.967	104.9	.031	105.6	.903	154.8
11500	.466	21.2	1.051	94.2	.035	95.1	.887	150.9
12000	.251	9.9	1.167	85.6	.040	83.4	.894	142.8
12500	.087	73.9	1.214	70.1	.039	65.3	.873	136.8
13000	.307	108.5	1.114	55.1	.038	39.5	.858	129.7
13500	.475	90.2	1.053	41.7	.038	10.3	.873	122.5
14000	.603	73.4	.926	18.0	.043	-14.2	.872	109.5

FLX207MH-12

X, Ku Band Power GaAs FET

Case Style "MH" Metal-Ceramic Hermetic Package

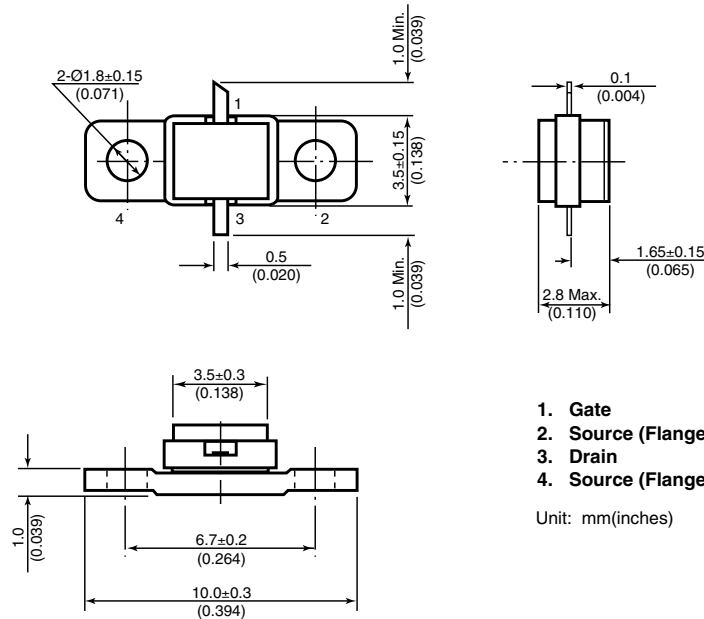

For further information please contact:

FUJITSU COMPOUND SEMICONDUCTOR, INC.

2355 Zanker Rd.
San Jose, CA 95131-1138, U.S.A.
Phone: (408) 232-9500
FAX: (408) 428-9111
www.fcsi.fujitsu.com

FUJITSU MICROELECTRONICS, LTD.

Compound Semiconductor Division
Network House
Norreys Drive
Maidenhead, Berkshire SL6 4FJ
Phone: +44 (0)1628 504800
FAX: +44 (0)1628 504888

CAUTION

Fujitsu Compound Semiconductor Products contain **gallium arsenide (GaAs)** which can be hazardous to the human body and the environment. For safety, observe the following procedures:

- Do not put these products into the mouth.
- Do not alter the form of this product into a gas, powder, or liquid through burning, crushing, or chemical processing as these by-products are dangerous to the human body if inhaled, ingested, or swallowed.
- Observe government laws and company regulations when discarding this product. This product must be discarded in accordance with methods specified by applicable hazardous waste procedures.

Fujitsu Limited reserves the right to change products and specifications without notice. The information does not convey any license under rights of Fujitsu Limited or others.

© 1998 FUJITSU COMPOUND SEMICONDUCTOR, INC.
Printed in U.S.A. FCSI0598M200