

LM150QML

3-Amp Adjustable Regulators

General Description

The LM150 adjustable 3-terminal positive voltage regulator is capable of supplying in excess of 3A over a 1.2V to 33V output range. It is exceptionally easy to use and requires only 2 external resistors to set the output voltage. Further, both line and load regulation are comparable to discrete designs. Also, the LM150 is packaged in standard transistor package which is easily mounted and handled.

In addition to higher performance than fixed regulators, the LM150 offers full overload protection available only in IC's. Included on the chip are current limit, thermal overload protection and safe area protection. All overload protection circuitry remains fully functional even if the adjustment terminal is accidentally disconnected.

Normally, no capacitors are needed unless the device is situated more than 6 inches from the input filter capacitors in which case an input bypass is needed. An output capacitor can be added to improve transient response, while bypassing the adjustment pin will increase the regulator's ripple rejection.

Besides replacing fixed regulators or discrete designs, the LM150 is useful in a wide variety of other applications. Since the regulator is "floating" and sees only the input-to-output

differential voltage, supplies of several hundred volts can be regulated as long as the maximum input to output differential is not exceeded, i.e., avoid short-circuiting the output.

By connecting a fixed resistor between the adjustment pin and output, the LM150 can be used as a precision current regulator. Supplies with electronic shutdown can be achieved by clamping the adjustment terminal to ground which programs the output to 1.2V where most loads draw little current.

Features

- Adjustable output down to 1.2V
- Guaranteed 3A output current
- Guaranteed thermal regulation
- Output is short circuit protected
- Current limit constant with temperature
- 86 dB ripple rejection

Applications

- Adjustable power supplies
- Constant current regulators
- Battery chargers

Ordering Information

NS Part Number	JAN Part Number	NS Package Number	Package Description
LM150K/883	5962-8767501XA	K02C	2LD T0-3 Metal Can

Connection Diagram

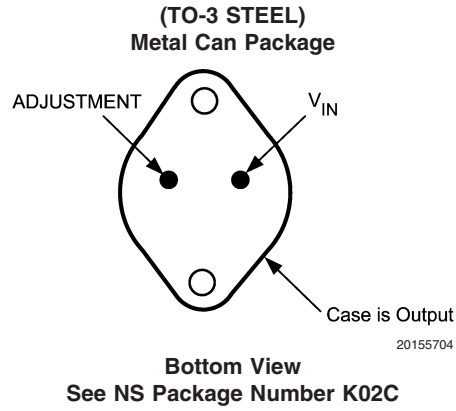

Schematic Diagram

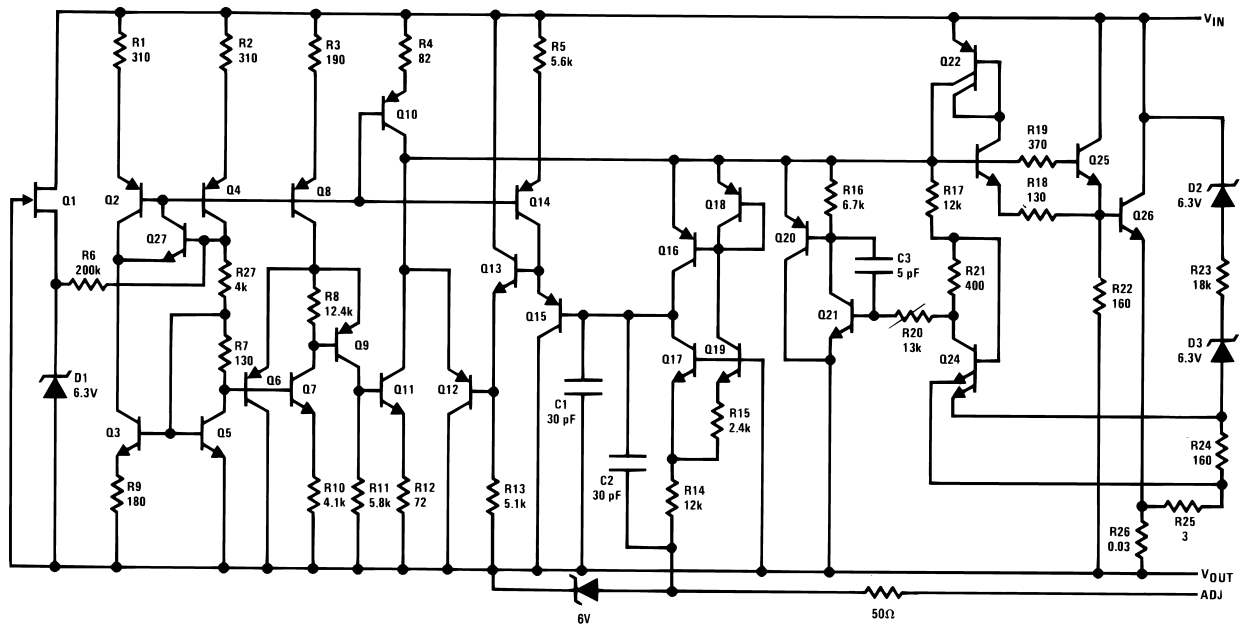

20155710

Absolute Maximum Ratings (Note 1)

Power Dissipation (Note 2)	Internally Limited
Input-Output Voltage Differential	+35V
Storage Temperature	$-65^{\circ}\text{C} \leq T_A \leq +150^{\circ}\text{C}$
Lead Temperature (Soldering, 10 sec.)	300°C
ESD Tolerance	TBD
Operating Temperature Range	$-55^{\circ}\text{C} \leq T_A \leq +125^{\circ}\text{C}$

Quality Conformance Inspection

Mil-Std-883, Method 5005 - Group A

Subgroup	Description	Temp °C
1	Static tests at	25
2	Static tests at	125
3	Static tests at	-55
4	Dynamic tests at	25
5	Dynamic tests at	125
6	Dynamic tests at	-55
7	Functional tests at	25
8A	Functional tests at	125
8B	Functional tests at	-55
9	Switching tests at	25
10	Switching tests at	125
11	Switching tests at	-55
12	Settling time at	25
13	Settling time at	125
14	Settling time at	-55

LM150 Electrical Characteristics

DC Parameters

The following conditions apply, unless otherwise specified.

DC: $V_{\text{Diff}} = 5\text{V}$, $V_{\text{O}} = V_{\text{Ref}}$, $I_{\text{O}} = 1.5\text{A}$.

Symbol	Parameter	Conditions	Notes	Min	Max	Unit	Sub-groups
V_{Ref}	Reference Voltage			1.2	1.3	V	1, 2, 3
		$V_{\text{Diff}} = 3.0\text{V}$, $I_{\text{L}} = 10\text{mA}$		1.2	1.3	V	1, 2, 3
		$V_{\text{Diff}} = 3.0\text{V}$, $I_{\text{L}} = 3.0\text{A}$		1.2	1.3	V	1, 2, 3
		$V_{\text{Diff}} = 35\text{V}$, $I_{\text{L}} = 10\text{mA}$		1.2	1.3	V	1, 2, 3
		$V_{\text{Diff}} = 10\text{V}$, $I_{\text{L}} = 3.0\text{A}$	(Note 9)	1.2	1.3	V	1, 2, 3
		$V_{\text{Diff}} = 30\text{V}$, $I_{\text{L}} = 300\text{mA}$		1.2	1.3	V	1, 2, 3
V_{Line}	Line Regulation	$3\text{V} \leq V_{\text{Diff}} \leq 35\text{V}$, $I_{\text{Load}} = 10\text{mA}$	(Note 6), (Note 3)	-3.8	3.8	mV	1
			(Note 6), (Note 3)	-19.0	19.0	mV	2, 3

LM150 Electrical Characteristics (Continued)

DC Parameters (Continued)

The following conditions apply, unless otherwise specified.

DC: $V_{\text{Diff}} = 5\text{V}$, $V_{\text{O}} = V_{\text{Ref}}$, $I_{\text{O}} = 1.5\text{A}$.

Symbol	Parameter	Conditions	Notes	Min	Max	Unit	Sub-groups
V_{Load}	Load Regulation	$10\text{mA} \leq I_{\text{L}} \leq 3\text{A}$, $V_{\text{O}} = V_{\text{Ref}}$	(Note 5), (Note 10), (Note 3)	-3.6	3.6	mV	1
			(Note 5), (Note 10), (Note 3)	-12.0	12.0	mV	2, 3
		$V_{\text{Diff}} = 30\text{V}$, $10\text{mA} \leq I_{\text{L}} \leq 300\text{mA}$	(Note 3)	-2.0	2.0	mV	1
			(Note 3)	-5.0	5.0	mV	2, 3
		$10\text{mA} \leq I_{\text{L}} \leq 3\text{A}$, $V_{\text{O}} = 5.0\text{V}$	(Note 5), (Note 7), (Note 3)	-15.0	15.0	mV	1
			(Note 5), (Note 7), (Note 3)	-50.0	50.0	mV	2, 3
T_{Reg}	Thermal Regulation	$t = 20\text{mS}$	(Note 8)	-9.75	9.75	mV	1
I_{Adj}	Adjust Pin Current				100	μA	1, 2, 3
		$V_{\text{Diff}} = 35\text{V}$, $I_{\text{O}} = 10\text{mA}$			100	μA	1, 2, 3
I_{Q}	Quiescent Current				5.0	mA	1, 2, 3
		$V_{\text{Diff}} = 35\text{V}$			5.0	mA	1, 2, 3
ΔI_{Adj}	Delta Adjustment Current	$3\text{V} \leq V_{\text{Diff}} \leq 35\text{V}$, $I_{\text{O}} = 10\text{mA}$		-5.0	5.0	μA	1, 2, 3
		$10\text{mA} \leq I_{\text{L}} \leq 3\text{A}$		-5.0	5.0	μA	1, 2, 3
		$V_{\text{Diff}} = 30\text{V}$, $10\text{mA} \leq I_{\text{L}} \leq 300\text{mA}$		-5.0	5.0	μA	1, 2, 3
	Current Limit	$V_{\text{Diff}} = 10\text{V}$		3.0		A	1, 2, 3
		$V_{\text{Diff}} = 30\text{V}$		0.3		A	1, 2, 3
$\Delta V_{\text{O}} / \Delta t$	Long Term Stability	$T_{\text{A}} = +125^{\circ}\text{C}$, $t = 1000\text{Hrs}$, $V_{\text{Diff}} = 3.0\text{V}$, $I_{\text{L}} = 10\text{mA}$	(Note 4)		1.0	$\%/V_{\text{O}}$	2
V_{Drop}	Voltage Dropout	$V_{\text{Diff}} = 2.9\text{V}$, $I_{\text{L}} = 3\text{A}$		-100	100	mV	1, 2, 3

AC Parameters

Symbol	Parameter	Conditions	Notes	Min	Max	Unit	Sub-groups
RR	Ripple Rejection	$f = 120\text{Hz}$, $e_{\text{r}} = 1V_{\text{RMS}}$, $C_{\text{Adj}} = 10\mu\text{F}$, $V_{\text{O}} = 10\text{V}$		66		dB	4, 5, 6

Note 1: Absolute Maximum Ratings indicate limits beyond which damage to the device may occur. Operating Ratings indicate conditions for which the device is functional, but do not guarantee specific performance limits. For guaranteed specifications and test conditions, see the Electrical Characteristics. The guaranteed specifications apply only for the test conditions listed. Some performance characteristics may degrade when the device is not operated under the listed test conditions.

Note 2: The maximum power dissipation must be derated at elevated temperatures and is dictated by T_{Jmax} (maximum junction temperature), θ_{JA} (package junction to ambient thermal resistance), and T_{A} (ambient temperature). The maximum allowable power dissipation at any temperature is $P_{\text{Dmax}} = (T_{\text{Jmax}} - T_{\text{A}})/\theta_{\text{JA}}$ or the number given in the Absolute Maximum Ratings, whichever is lower.

Note 3: Regulation is measured at a constant junction temperature, using pulse testing with a low duty cycle. Changes in output voltage due to heating effects are covered under the specifications for thermal regulation.

Note 4: Periodic Group C testing.

Note 5: These V_{O} conditions are worst case

Note 6: Limits = 0.01% of V_{O} @ 25°C , 0.05% @ -55°C , $+125^{\circ}\text{C}$ per volt of V_{Diff} change at $V_{\text{O}} = V_{\text{Ref}}$.

Note 7: Limits = 0.3% of V_{O} @ 25°C , 1.0% @ -55°C , $+125^{\circ}\text{C}$ @ $V_{\text{O}} = 5.0\text{V}$.

Note 8: Limits = 0.01% of V_{O} @ 25°C per Watt of power dissipation at $P_{\text{D}} = 7.5\text{W}$.

Note 9: Represents worst case power dissipation of 30W.

Note 10: Limits are equivalent to 15mV @ 25°C and 50mV @ -55°C , $+125^{\circ}\text{C}$ @ $V_{\text{O}} = 5.0\text{V}$.

Typical Performance Characteristics

Load Regulation

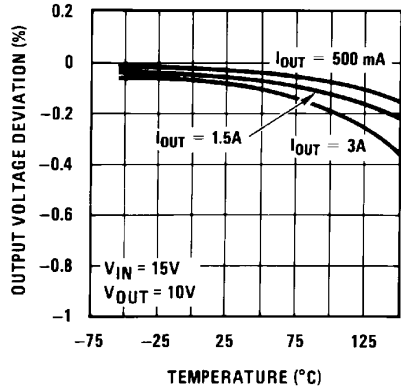

20155733

Current Limit

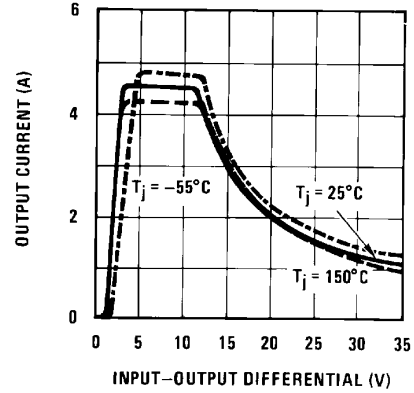

20155734

Adjustment Current

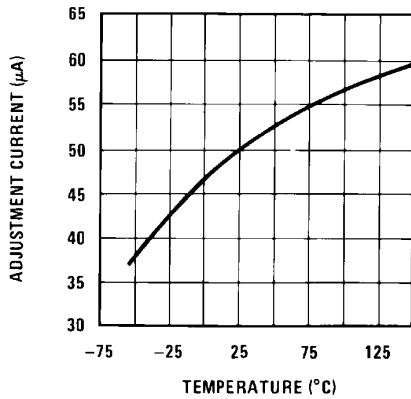

20155735

Dropout Voltage

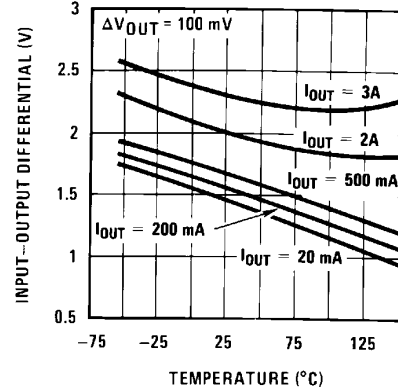

20155736

Temperature Stability

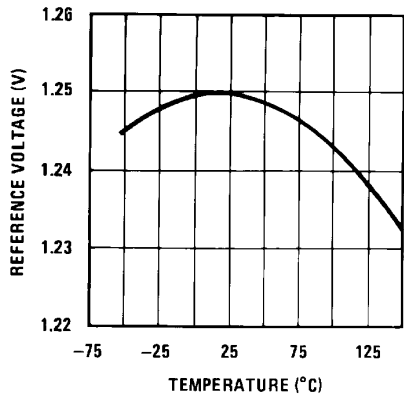

20155737

Minimum Operating Current

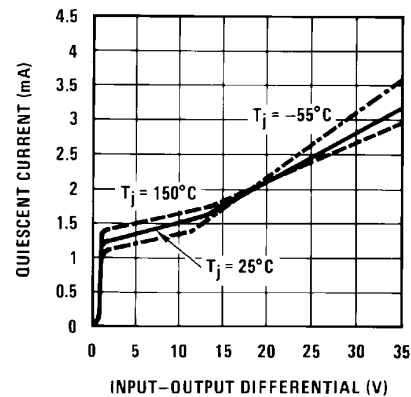

20155738

Typical Performance Characteristics (Continued)

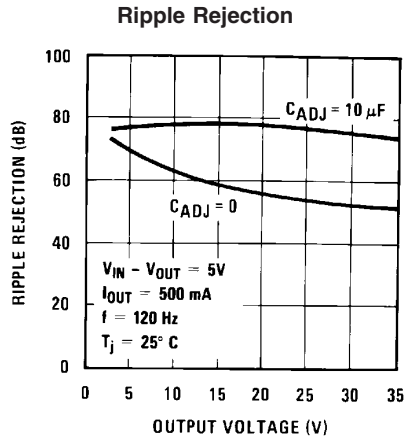

20155739

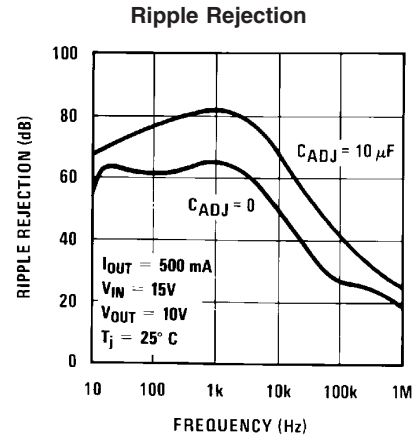

20155740

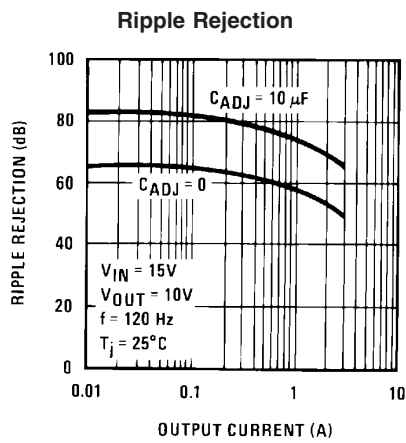

20155741

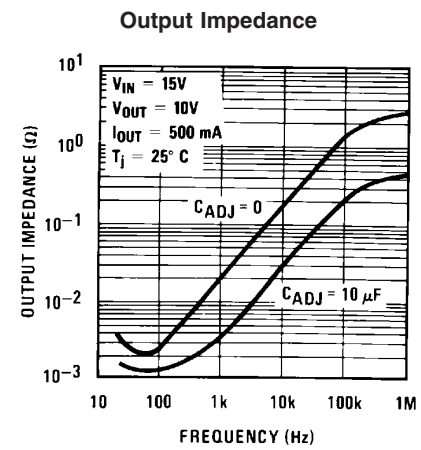

20155742

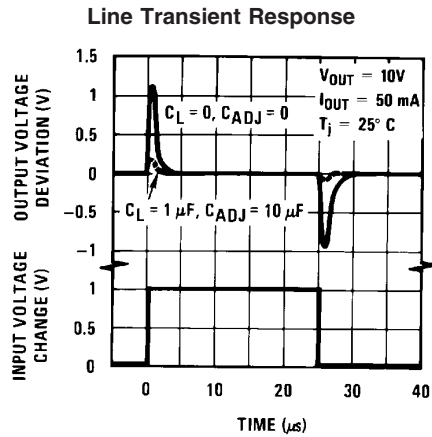

20155743

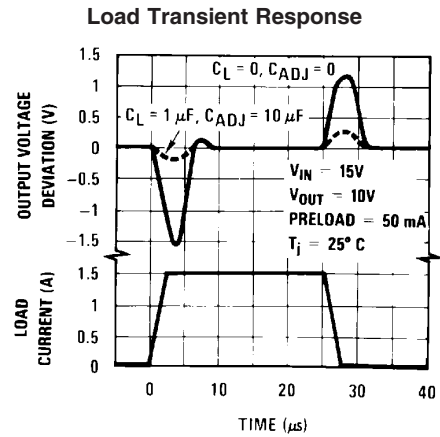

20155744

Application Hints

In operation, the LM150 develops a nominal 1.25V reference voltage, V_{REF} , between the output and adjustment terminal. The reference voltage is impressed across program resistor R1 and, since the voltage is constant, a constant current I_1 then flows through the output set resistor R2, giving an output voltage of

$$V_{OUT} = V_{REF} \left(1 + \frac{R2}{R1} \right) + I_{ADJ} R2.$$

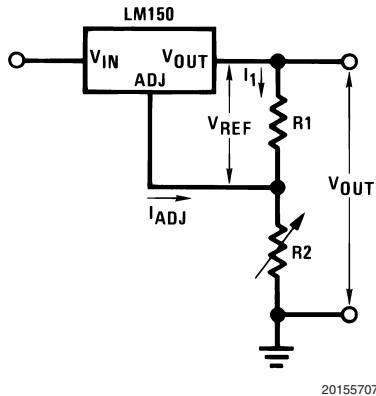

FIGURE 1.

Since the 50 μ A current from the adjustment terminal represents an error term, the LM150 was designed to minimize I_{Adj} and make it very constant with line and load changes. To do this, all quiescent operating current is returned to the output establishing a minimum load current requirement. If there is insufficient load on the output, the output will rise.

EXTERNAL CAPACITORS

An input bypass capacitor is recommended. A 0.1 μ F disc or 1 μ F solid tantalum on the input is suitable input bypassing for almost all applications. The device is more sensitive to the absence of input bypassing when adjustment or output capacitors are used but the above values will eliminate the possibility of problems.

The adjustment terminal can be bypassed to ground on the LM150 to improve ripple rejection. This bypass capacitor prevents ripple from being amplified as the output voltage is increased. With a 10 μ F bypass capacitor 86 dB ripple rejection is obtainable at any output level. Increases over 10 μ F do not appreciably improve the ripple rejection at frequencies above 120 Hz. If the bypass capacitor is used, it is sometimes necessary to include protection diodes to prevent the capacitor from discharging through internal low current paths and damaging the device.

In general, the best type of capacitors to use is solid tantalum. Solid tantalum capacitors have low impedance even at high frequencies. Depending upon capacitor construction, it takes about 25 μ F in aluminum electrolytic to equal 1 μ F solid tantalum at high frequencies. Ceramic capacitors are also good at high frequencies, but some types have a large decrease in capacitance at frequencies around 0.5 MHz. For this reason, 0.01 μ F disc may seem to work better than a 0.1 μ F disc as a bypass.

Although the LM150 is stable with no output capacitors, like any feedback circuit, certain values of external capacitance

can cause excessive ringing. This occurs with values between 500 pF and 5000 pF. A 1 μ F solid tantalum (or 25 μ F aluminum electrolytic) on the output swamps this effect and insures stability.

LOAD REGULATION

The LM150 is capable of providing extremely good load regulation but a few precautions are needed to obtain maximum performance. The current set resistor connected between the adjustment terminal and the output terminal (usually 240 Ω) should be tied directly to the output (case) of the regulator rather than near the load. This eliminates line drops from appearing effectively in series with the reference and degrading regulation. For example, a 15V regulator with 0.05 Ω resistance between the regulator and load will have a load regulation due to line resistance of 0.05 Ω x I_{OUT} . If the set resistor is connected near the load the effective line resistance will be 0.05 Ω (1 + R2/R1) or in this case, 11.5 times worse.

Figure 2 shows the effect of resistance between the regulator and 240 Ω set resistor.

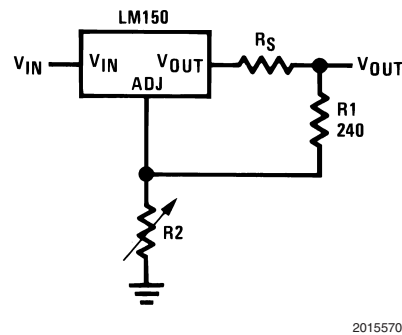

FIGURE 2. Regulator with Line Resistance in Output Lead

With the TO-3 package, it is easy to minimize the resistance from the case to the set resistor, by using two separate leads to the case. The ground of R2 can be returned near the ground of the load to provide remote ground sensing and improve load regulation.

PROTECTION DIODES

When external capacitors are used with *any* IC regulator it is sometimes necessary to add protection diodes to prevent the capacitors from discharging through low current points into the regulator. Most 10 μ F capacitors have low enough internal series resistance to deliver 20A spikes when shorted. Although the surge is short, there is enough energy to damage parts of the IC.

When an output capacitor is connected to a regulator and the input is shorted, the output capacitor will discharge into the output of the regulator. The discharge current depends on the value of the capacitor, the output voltage of the regulator, and the rate of decrease of V_{IN} . In the LM150, this discharge path is through a large junction that is able to sustain 25A surge with no problem. This is not true of other types of positive regulators. For output capacitors of 25 μ F or less, there is no need to use diodes.

The bypass capacitor on the adjustment terminal can discharge through a low current junction. Discharge occurs when *either* the input or output is shorted. Internal to the LM150 is a 50 Ω resistor which limits the peak discharge current. No protection is needed for output voltages of 25V

Application Hints (Continued)

or less and 10 μF capacitance. Figure 3 shows an LM150

with protection diodes included for use with outputs greater than 25V and high values of output capacitance.

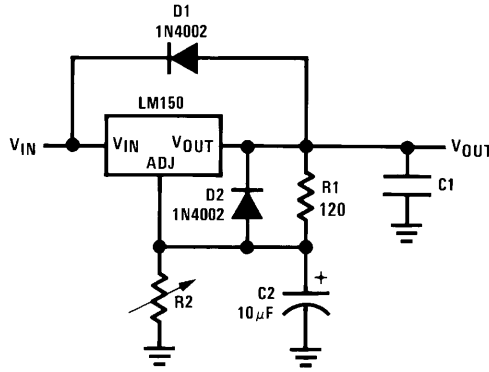

20155709

D1 protects against C1
D2 protects against C2

$$V_{OUT} = 1.25V \left(1 + \frac{R2}{R1} \right) + I_{ADJ}R2$$

FIGURE 3. Regulator with Protection Diodes

Typical Applications

1.2V–25V Adjustable Regulator

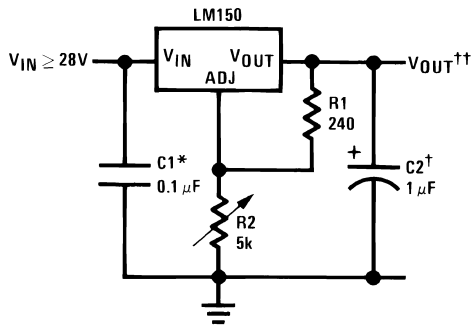

20155701

Full output current not available at high input-output voltages.

†Optional — improves transient response. Output capacitors in the range of 1 μF to 1000 μF of aluminum or tantalum electrolytic are commonly used to provide improved output impedance and rejection of transients.

*Needed if device is more than 6 inches from filter capacitors.

$$\dagger\dagger V_{OUT} = 1.25V \left(1 + \frac{R2}{R1} \right) + I_{ADJ} (R2)$$

Note: Usually R1 = 240Ω for LM150 and R1 = 120Ω.

Precision Power Regulator with Low Temperature Coefficient

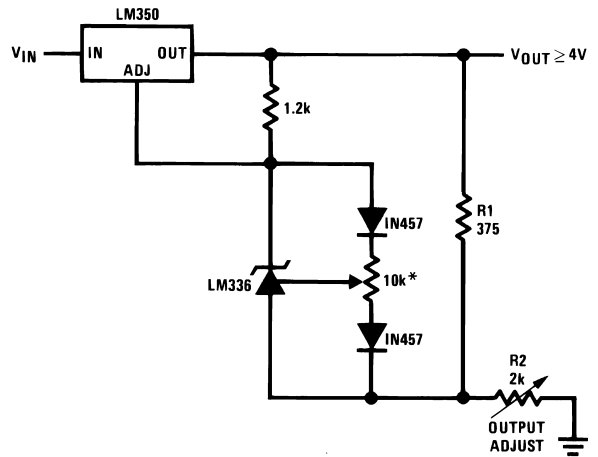

20155713

*Adjust for 3.75V across R1

Slow Turn-ON 15V Regulator

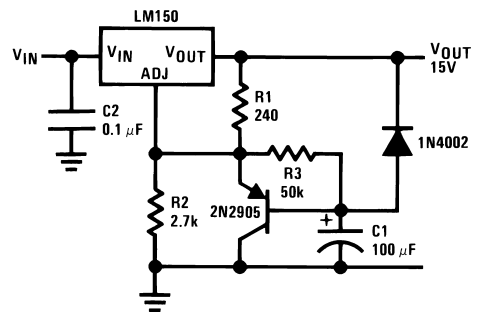

20155714

Typical Applications (Continued)

Adjustable Regulator with Improved Ripple Rejection

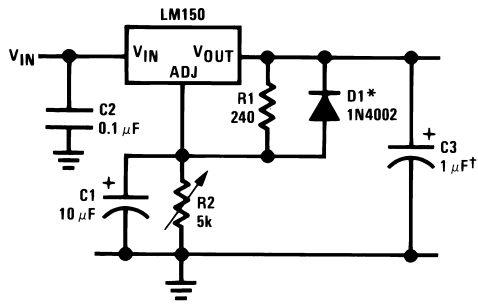

20155715

†Solid tantalum

*Discharges C1 if output is shorted to ground

High Stability 10V Regulator

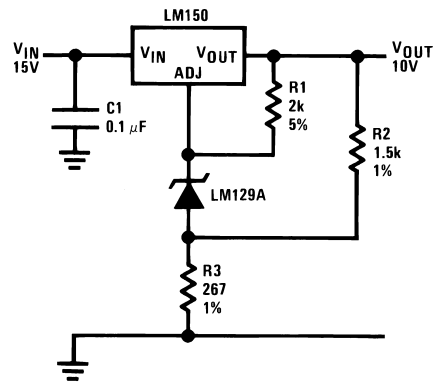

20155716

Digitally Selected Outputs

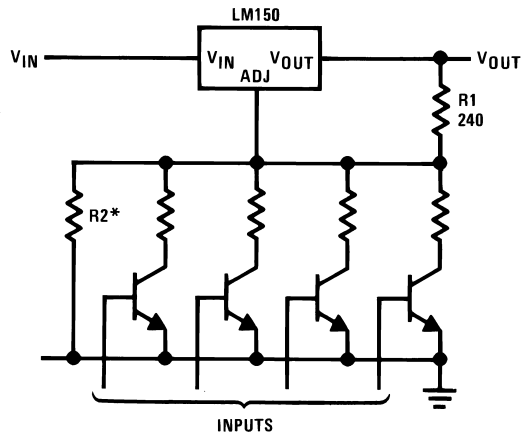

20155717

*Sets maximum V_O

Regulator and Voltage Reference

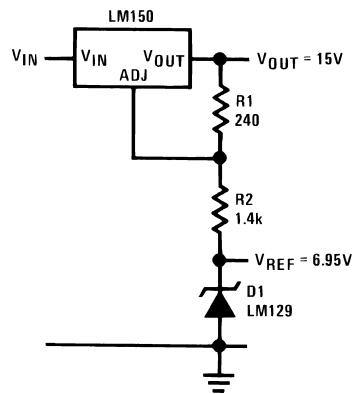

20155703

Typical Applications (Continued)

10A Regulator

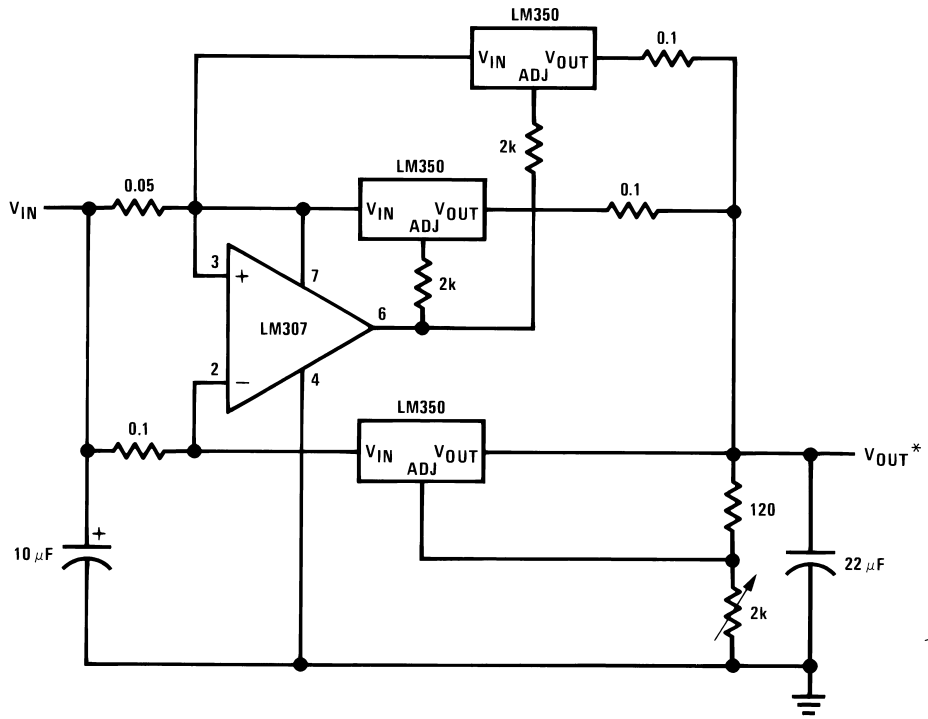

*Minimum load current 50 mA

20155718

5V Logic Regulator with Electronic Shutdown*

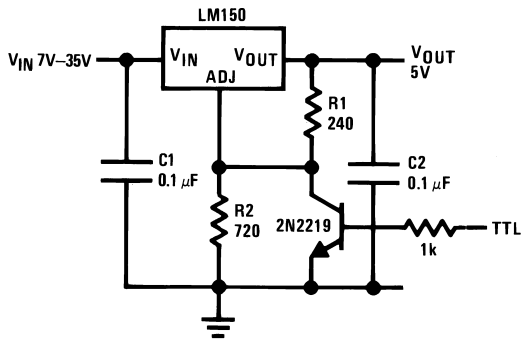

*Minimum output \approx 1.2V

20155719

Typical Applications (Continued)

0 to 30V Regulator

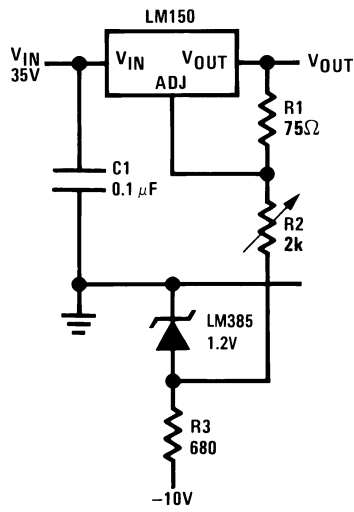

20155720

Full output current not available at high input-output voltages

5A Constant Voltage/Constant Current Regulator

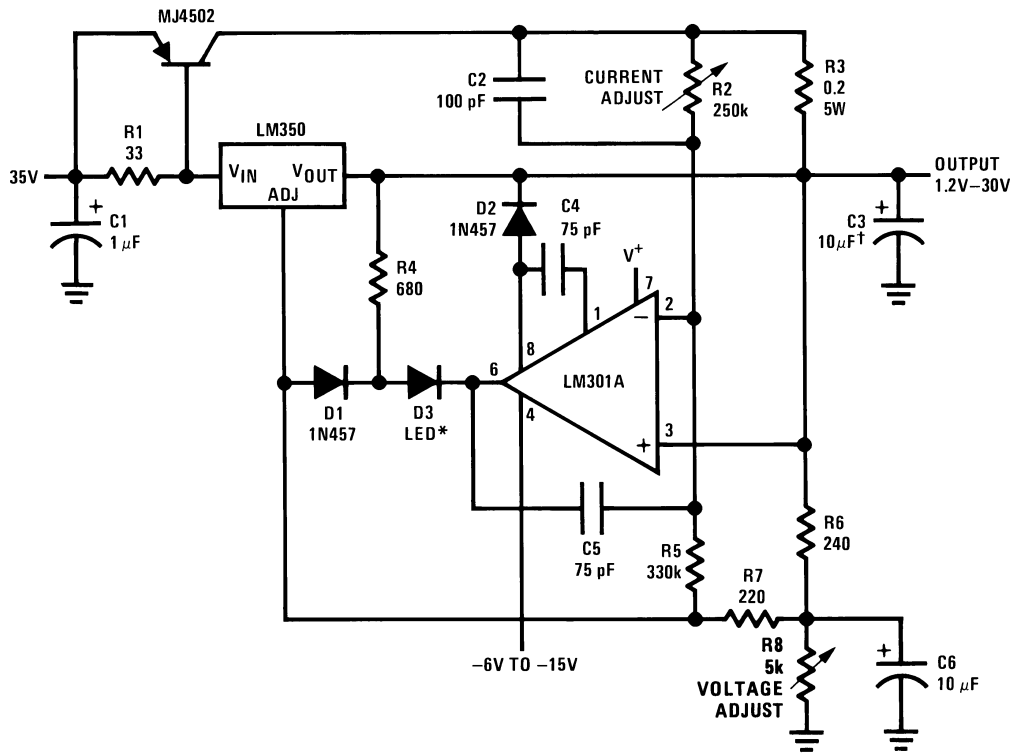

20155721

†Solid tantalum

*Lights in constant current mode

Typical Applications (Continued)

12V Battery Charger

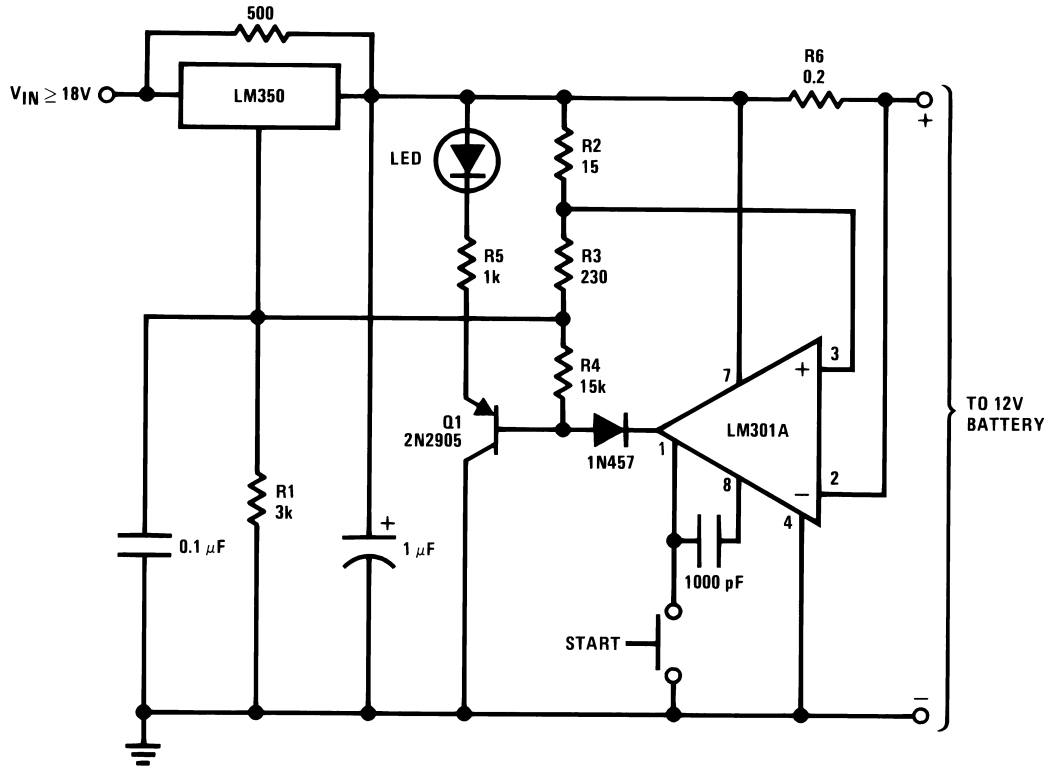

20155722

Adjustable Current Regulator

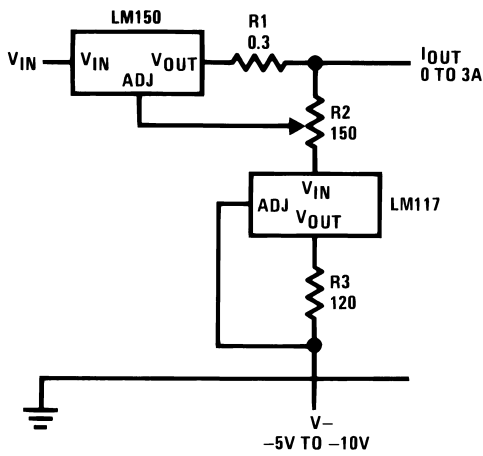

20155723

1.2V–20V Regulator with Minimum Program Current

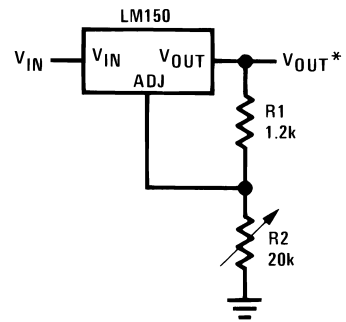

*Minimum output current = 4 mA

20155725

Precision Current Limiter

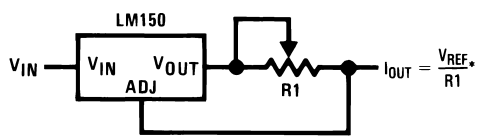

20155724

* $0.4 \leq R_1 \leq 120\Omega$

3A Current Regulator

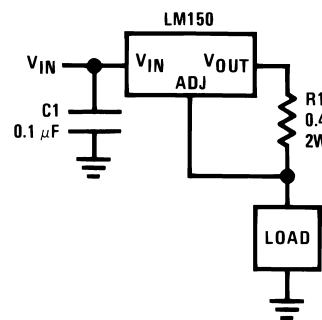

20155726

Typical Applications (Continued)

Tracking Preregulator

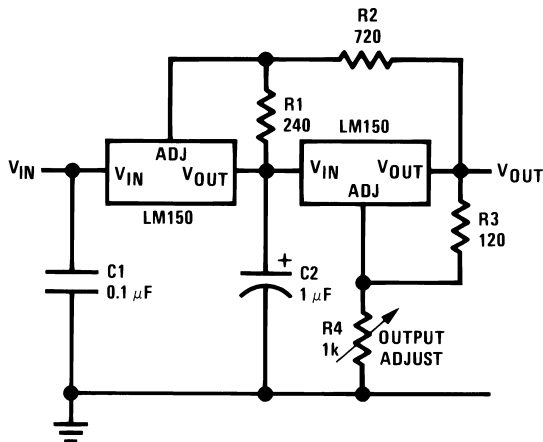

20155727

Adjusting Multiple On-Card Regulators with Single Control*

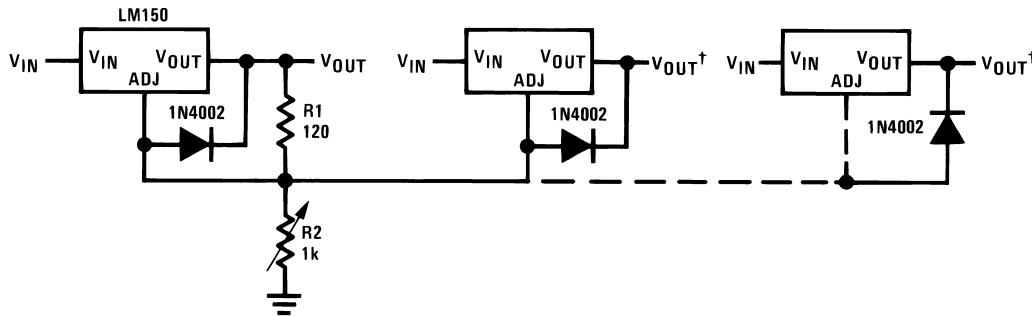

20155728

†Minimum load— 10 mA

*All outputs within ±100 mV

AC Voltage Regulator

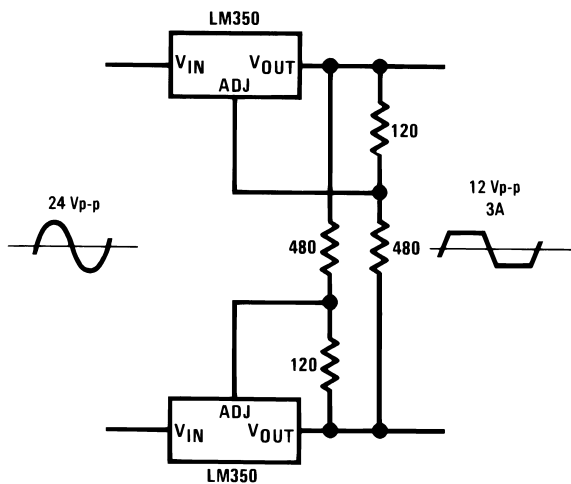

20155729

Simple 12V Battery Charger

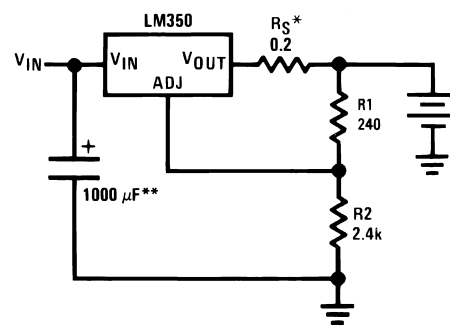

20155730

*R_S—sets output impedance of charger: $Z_{OUT} = R_S \left(1 + \frac{R_2}{R_1} \right)$

20155748

Use of R_S allows low charging rates with fully charged battery.

**1000 μF is recommended to filter out any input transients

Typical Applications (Continued)

Temperature Controller

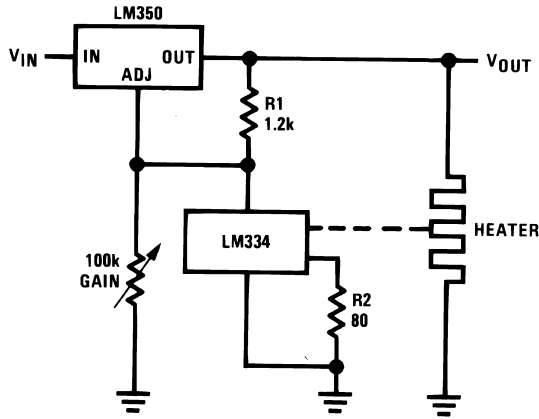

20155711

Light Controller

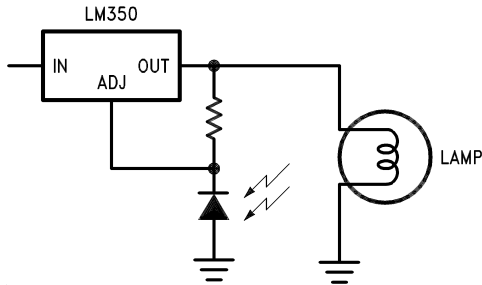

20155712

Adjustable 10A Regulator

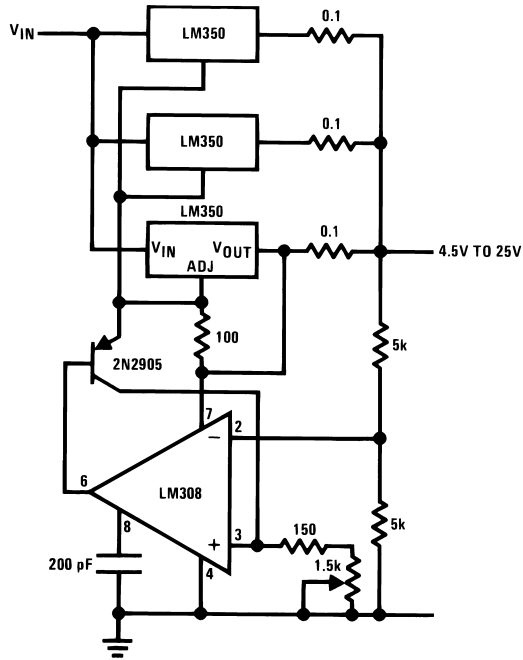

20155731

Current Limited 6V Charger

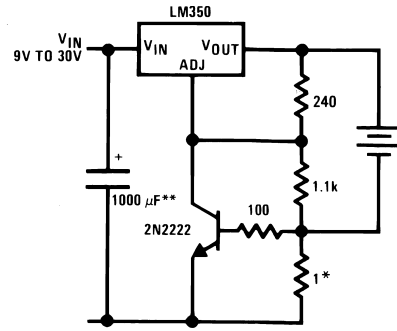

20155732

*Sets peak current (2A for 0.3Ω)

**1000 μF is recommended to filter out any input transients.

6A Regulator

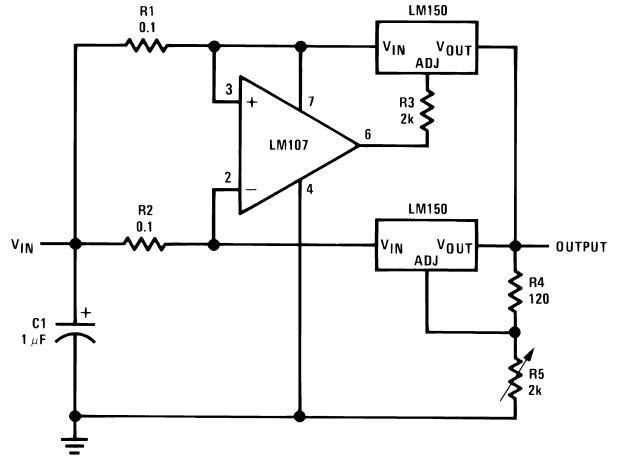

20155702

Revision History

Released	Revision	Section	Originator	Changes
03/10/06	A	New Release, Corporate format	L. Lytle	1 MDS data sheet converted into one Corp. data sheet format. MNLM150-X Rev. 0BL will be archived.

Physical Dimensions inches (millimeters) unless otherwise noted

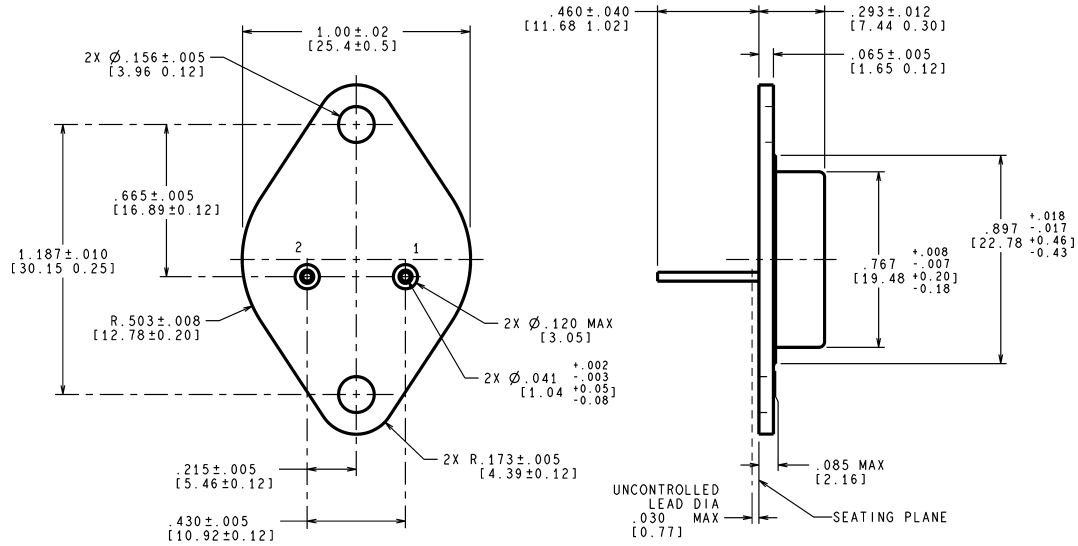

CONTROLLING DIMENSION IS INCH
VALUES IN [] ARE MILLIMETERS

MIL-PRF-38535
CONFIGURATION CONTROL

K02C (Rev E)

**2 Lead TO-3 Metal Can Package (K)
NS Package Number K02C**

National does not assume any responsibility for use of any circuitry described, no circuit patent licenses are implied and National reserves the right at any time without notice to change said circuitry and specifications.

For the most current product information visit us at www.national.com.

LIFE SUPPORT POLICY

NATIONAL'S PRODUCTS ARE NOT AUTHORIZED FOR USE AS CRITICAL COMPONENTS IN LIFE SUPPORT DEVICES OR SYSTEMS WITHOUT THE EXPRESS WRITTEN APPROVAL OF THE PRESIDENT AND GENERAL COUNSEL OF NATIONAL SEMICONDUCTOR CORPORATION. As used herein:

1. Life support devices or systems are devices or systems which, (a) are intended for surgical implant into the body, or (b) support or sustain life, and whose failure to perform when properly used in accordance with instructions for use provided in the labeling, can be reasonably expected to result in a significant injury to the user.
2. A critical component is any component of a life support device or system whose failure to perform can be reasonably expected to cause the failure of the life support device or system, or to affect its safety or effectiveness.

BANNED SUBSTANCE COMPLIANCE

National Semiconductor manufactures products and uses packing materials that meet the provisions of the Customer Products Stewardship Specification (CSP-9-111C2) and the Banned Substances and Materials of Interest Specification (CSP-9-111S2) and contain no "Banned Substances" as defined in CSP-9-111S2.

Leadfree products are RoHS compliant.



National Semiconductor
Americas Customer
Support Center
Email: new.feedback@nsc.com
Tel: 1-800-272-9959

National Semiconductor
Europe Customer Support Center
Fax: +49 (0) 180-530 85 86
Email: europa.support@nsc.com
Deutsch Tel: +49 (0) 69 9508 6208
English Tel: +44 (0) 870 24 0 2171
Français Tel: +33 (0) 1 41 91 8790

National Semiconductor
Asia Pacific Customer
Support Center
Email: ap.support@nsc.com

National Semiconductor
Japan Customer Support Center
Fax: 81-3-5639-7507
Email: jpn.feedback@nsc.com
Tel: 81-3-5639-7560

www.national.com