

GaAs SP3T 2.5V High Power Switch

DC - 2.5 GHz

Feb 12 2002

Preliminary

MASWSS0033

Features

- Low Harmonic Knee Voltage < 2.5V
- Low Harmonics > 65 dBc at +34 dBm & 1 GHz
- Low Insertion Loss 0.45 dB at 1 GHz
- High Isolation 18.5 dB at 2 GHz
- FQFP 12-lead 3x3mm Low Profile Package
- 0.5 micron GaAs pHEMT Process

Description

M/A-COM's MASWSS0033 is a GaAs PHEMT MMIC SP3T high power switch in a low cost miniature FQFP 12-lead 3x3mm thin profile package. This package represents a lower profile than standard FQFP style, featuring a 0.8mm maximum thickness.

The MASWSS0033 is ideally suited for applications where high power, low control voltage, low insertion loss, high isolation, small size and low cost are required. Typical applications are for GSM and DCS handset systems that connect separate transmit and receive functions to a common antenna, as well other handset and related applications. This part can be used in all systems operating up to 2.5 GHz requiring high power at low control voltage.

The MASWSS0033 is fabricated using a 0.5 micron gate length GaAs PHEMT process. The process features full passivation for performance and reliability.

Absolute Maximum Ratings ¹

Parameter	Absolute Maximum
Max Input Power (0.5 - 2.5 GHz, 2.5V Control)	+38 dBm
Operating Voltage	+8.5 volts
Operating Temperature	-40 °C to +85 °C
Storage Temperature	-65 °C to +150 °C

1. Exceeding any one or combination of these limits may cause permanent damage.

Functional Schematic

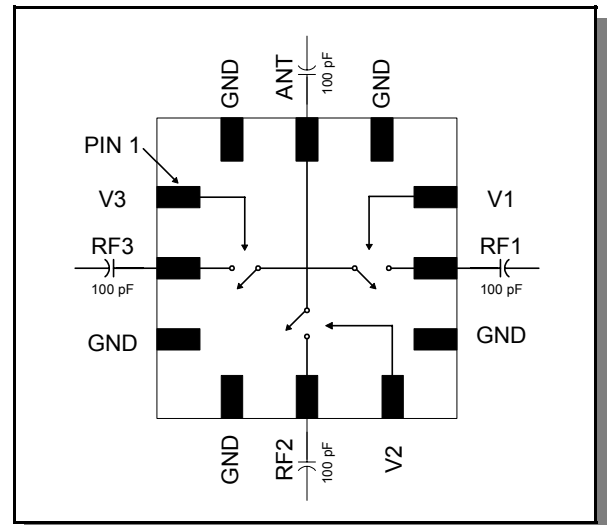

Pin Configuration

PIN No.	PIN Name	Description
1	V3	Control 3
2	RF3	RF Port 3
3	GND	RF Ground
4	GND	RF Ground
5	RF2	RF Port 2
6	V2	Control 2
7	GND	RF Ground
8	RF1	RF Port 1
9	V1	Control 1
10	GND	RF Ground
11	ANT	Antenna Port
12	GND	RF Ground
13	GND (paddle)	RF Ground

Parameter	Test Conditions	Units	Min.	Typ.	Max.
Insertion Loss	DC – 1 GHz	dB		0.5	0.65
	1 – 2 GHz	dB		0.6	0.8
	2 - 2.5 GHz	dB		0.8	1.0
Isolation	DC – 1 GHz	dB	23	25	
	1 – 2 GHz	dB	18	18.5	
	2 - 2.5 GHz	dB	15	16	
Return Loss	DC – 2.5 GHz	dB		20	
P1dB	V _c = 0V/2.5V	dBm		38	
2 nd Harmonic	1 GHz, P _{IN} = +34 dBm, V _c = 0V/2.5V	dBc	65		
3 rd Harmonic	1 GHz, P _{IN} = +34 dBm, V _c = 0V/2.5V	dBc	65		
Trise, Tfall	10% to 90% RF, 90% to 10% RF	μS		1	
Cross Modulation ANT - CELL ³	Two Tone +22 dBm, 1 MHz Spacing, 820 MHz,	dBm		59	
	Two Tone +19 dBm, 1 MHz Spacing, 1950 MHz,	dBm		57	
Cross Modulation ANT - PCS ³	Two Tones +22 dBm @ 820 & 821 MHz, One Tone -27 dBm @ 865 MHz	dBm		-108	
	Two Tones +17 dBm @ 1950 & 1951 MHz, One Tone -27 dBm @ 1870 MHz	dBm		TBD	
Ton, Toff	50% control to 90% RF, and 50% control to 10% RF	μS		1	
Transients	In Band	mV		10	
Gate Leakage	V _c = 2.5V	uA			100

2. Insertion Loss can be optimized by varying the DC Blocking Capacitor value, ie. 1000 pF for 100 MHz - 500 MHz, 100 pF for 0.5 GHz - 2.5 GHz.

3. IP3 slope versus input power is approximately 1.5:1.

Truth Table ⁴

V1	V2	V3	ANT- RF1	ANT - RF2	ANT - RF3
+2.5 to +5V	0 ± 0.2V	0 ± 0.2V	On	Off	Off
0 ± 0.2V	+2.5 to +5V	0 ± 0.2V	Off	On	Off
0 ± 0.2V	0 ± 0.2V	+2.5 to +5V	Off	Off	On

4. External DC blocking capacitors are required on all RF ports

Specifications subject to change without notice.

- North America: Tel. (800) 366-2266, Fax (800) 618-8883
- Asia/Pacific: Tel. +81-44-844-8296, Fax +81-44-844-8298
- Europe: Tel. +44 (1344) 869 595, Fax+44 (1344) 300 020

Visit www.macom.com for additional data sheets and product information.

tyco / Electronics

MACOM

Typical Performance Curves

Insertion Loss vs. Frequency,
25 °C, 100 pF

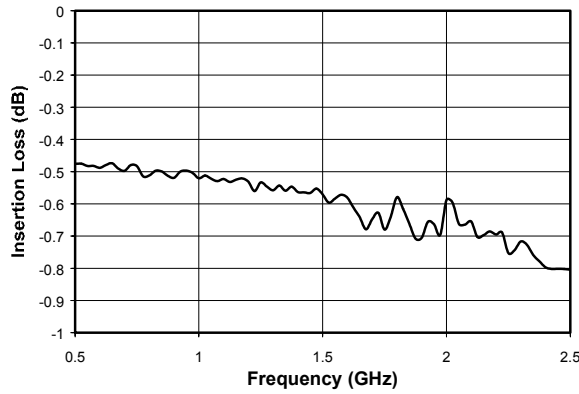

Isolation vs. Frequency,
25 °C, 100 pF

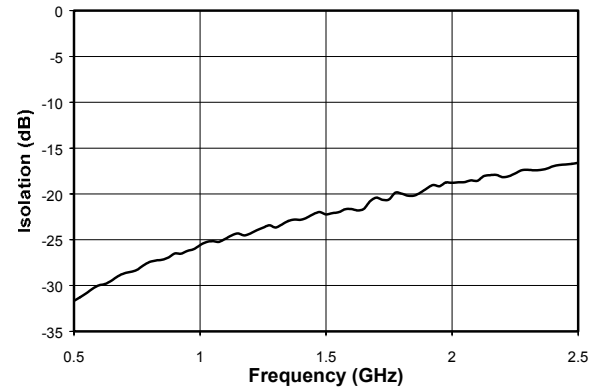

Harmonic Rejection vs. Frequency,
25 °C, 100 pF

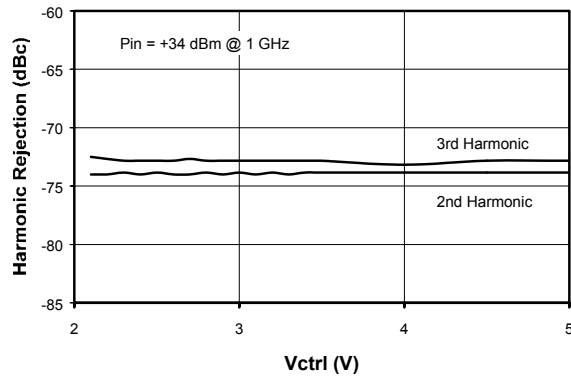

Specifications subject to change without notice.

- North America: Tel. (800) 366-2266, Fax (800) 618-8883
- Asia/Pacific: Tel. +81-44-844-8296, Fax +81-44-844-8298
- Europe: Tel. +44 (1344) 869 595, Fax +44 (1344) 300 020

Visit www.macom.com for additional data sheets and product information.



FQFP 12-lead 3x3 mm Low Profile

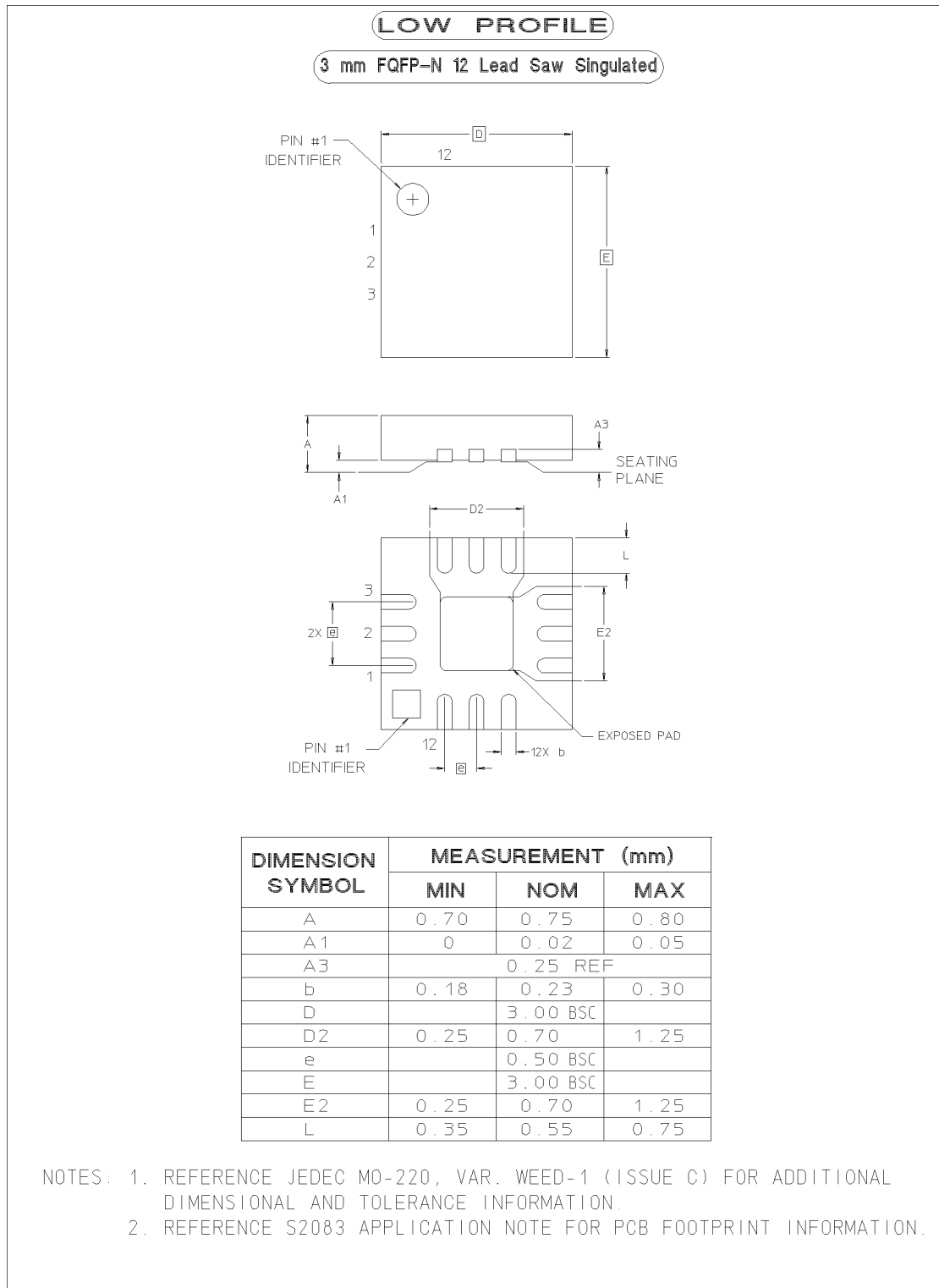

Specifications subject to change without notice.

- North America: Tel. (800) 366-2266, Fax (800) 618-8883
- Asia/Pacific: Tel. +81-44-844-8296, Fax +81-44-844-8298
- Europe: Tel. +44 (1344) 869 595, Fax +44 (1344) 300 020

Visit www.macom.com for additional data sheets and product information.

tyco / Electronics

MACOM

Handling Procedures

The following precautions should be observed to avoid damage:

Static Sensitivity

Gallium Arsenide Integrated Circuits are ESD sensitive and can be damaged by static electricity. Proper ESD techniques should be used when handling these devices.

Ordering Information

Part Number	Package
MASWSS0033	FQFP-N 12-lead Thin Plastic Package
MASWSS0033TR	1000 piece reel
MASWSS0033SMB	Sample Test Board

Specifications subject to change without notice.

- **North America:** Tel. (800) 366-2266, Fax (800) 618-8883
- **Asia/Pacific:** Tel.+81-44-844-8296, Fax +81-44-844-8298
- **Europe:** Tel. +44 (1344) 869 595, Fax+44 (1344) 300 020

Visit www.macom.com for additional data sheets and product information.

tyco / Electronics

MACOM