

MAS9184A

12 X 8-bit D to A Converter

- 12-bit serial data input
- Highly stable output buffer
- Serial data output for Daisy-Chaining

DESCRIPTION

The MAS9184 is a CMOS structured integrated circuit with 12 built-in D to A converter channels and 12 corresponding output buffer operational amplifiers. A simple 3-wire serial interface transfers

digital data from the micro controller. The output buffers operate in the entire voltage range from ground to the positive power supply rail.

FEATURES

- Twelve 8-bit DACs on a single monolithic chip
- Voltage level output
- SO 20 package
- Single +5V supply
- Power-on reset

APPLICATION

- High resolution monitors
- Automatic gain control
- Trimmer replacement

BLOCK DIAGRAM

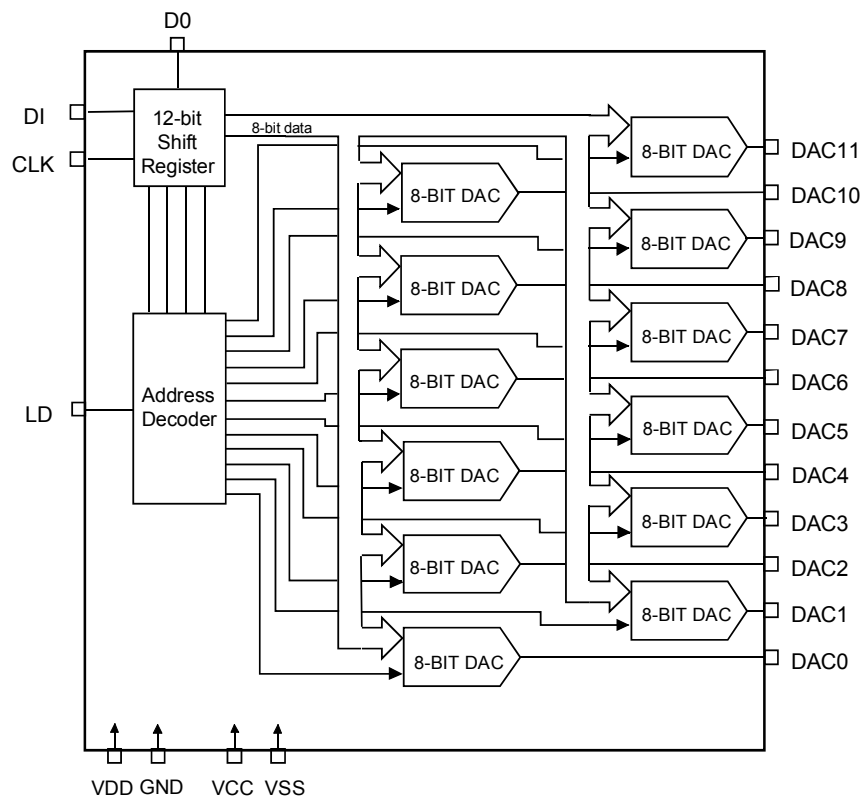

PIN CONFIGURATION

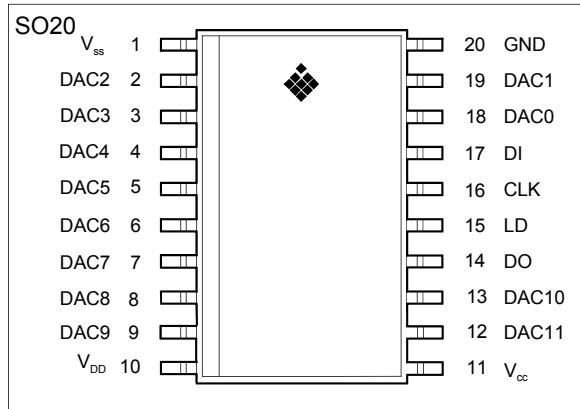

PIN DESCRIPTION

Pin name	SO	Function
V _{SS}	1	D/A converter low level reference voltage input terminal
DAC2	2	8-bit D/A converter output terminal
DAC3	3	8-bit D/A converter output terminal
DAC4	4	8-bit D/A converter output terminal
DAC5	5	8-bit D/A converter output terminal
DAC6	6	8-bit D/A converter output terminal
DAC7	7	8-bit D/A converter output terminal
DAC8	8	8-bit D/A converter output terminal
DAC9	9	8-bit D/A converter output terminal
V _{DD}	10	D-A converter high level reference voltage input terminal
V _{CC}	11	Power supply terminal
DAC10	12	8-bit D/A converter output terminal
DAC11	13	8-bit D/A converter output terminal
DO	14	Serial data output terminal
LD	15	Latch data terminal
CLK	16	Serial clock input terminal
DI	17	Serial data input terminal
DAC0	18	8-bit D/A converter output terminal
DAC1	19	8-bit D/A converter output terminal
GND	20	Digital and analog ground

ABSOLUTE MAXIMUM RATINGS

Parameter	Symbol	Conditions	Min	Max	Unit
Supply Voltage	V_{CC}		-0.3	7.0	V
High level reference voltage	V_{DD}		-0.3	7.0	V
Digital input voltage	V_{in}		-0.3	$V_{CC}+0.3$	V
Output voltage	V_{out}		-0.3	$V_{CC}+0.3$	V
Power dissipation	P_D			150	mW
Operating temperature	T_{amb}		-20	+85	°C
Storage temperature	T_S		-55	+125	°C

RECOMMENDED OPERATION CONDITIONS

($V_{CC}=V_{DD}=5V\pm 10\%$, $GND=V_{SS}=0V$, $T_a=-20\text{ }^\circ\text{C}$ to $+85\text{ }^\circ\text{C}$, unless otherwise noted)

Parameter	Symbol	Conditions	Min	Typ	Max	Unit
Supply Voltage	V_{CC}		4.5	5.0	5.5	V
Supply current	I_{CC}	CLK = 1MHz		2.5		mA
Input leakage current	I_{ILK}	$V_{in}=0V$ to V_{CC}	-10		10	uA

ELECTRICAL CHARACTERISTICS

◆ Digital inputs

($V_{CC} = V_{DD} = 5V \pm 10\%$, $GND = V_{SS} = 0V$, $T_a = -20\text{ }^\circ\text{C}$ to $+85\text{ }^\circ\text{C}$, unless otherwise noted)

Parameter	Symbol	Conditions	Min	Typ	Max	Unit
Input low voltage	V_{IL}				$3.0V_{CC}$	V
Input high voltage	V_{IH}		$0.7V_{CC}$			V

◆ Digital outputs

($V_{CC} = V_{DD} = 5V \pm 10\%$, $GND = V_{SS} = 0V$, $T_a = -20\text{ }^\circ\text{C}$ to $+85\text{ }^\circ\text{C}$, unless otherwise noted)

Parameter	Symbol	Conditions	Min	Typ	Max	Unit
Output low voltage	V_{OL}	$I_{OL} = 400\mu\text{A}$			0.4	V
Output high voltage	V_{OH}	$I_{OH} = -400\mu\text{A}$	$V_{CC}-0.4$			V

◆ Analog outputs

($V_{CC} = V_{DD} = 5V \pm 10\%$, $GND = V_{SS} = 0V$, $T_a = -20\text{ }^\circ\text{C}$ to $+85\text{ }^\circ\text{C}$, unless otherwise noted)

Parameter	Symbol	Conditions	Min	Typ	Max	Unit
Reference voltage pin current	I_{DD}		30	50	80	μA
D/A high level reference voltage range	V_{DD}		3.0		V_{CC}	V
D/A low level reference voltage range	V_{SS}		GND		$V_{CC}-3.0$	V
Buffer amplifier output voltage range	V_{AO}	$I_{AO} = 100\mu\text{A}$	0.1		$V_{CC}-0.1$	V
		$I_{AO} = 500\mu\text{A}$	0.2		$V_{CC}-0.2$	V
Buffer amplifier output drive range	I_{AO}		-5.0		5.0	mA
Differential nonlinearity	S_{DL}		-1.0		1.0	LSB
Nonlinearity	S_L		-1.5		1.5	LSB
Zero code error	S_{ZERO}		-1.0		1.0	LSB
Full scale error	S_{FULL}		-1.0		1.0	LSB
Output capacitive load	C_L				0.1	μF
Buffer amplifier output impedance	R_O			5		Ω

ELECTRICAL CHARACTERISTICS

◆ AC Characteristics

($V_{CC} = V_{DD} = 5V \pm 10\%$, $GND = V_{SS} = 0V$, $T_a = -20^\circ C$ to $+85^\circ C$, unless otherwise noted)

Parameter	Symbol	Conditions	Min	Typ	Max	Unit
Clock 'L' pulse width	t_{CKL}		100			ns
Clock 'H' pulse width	t_{CKH}		100			ns
Rise time	t_{CR}				200	ns
Fall time	t_{CF}				200	ns
Data setup time	t_{DCH}		30			ns
data hold time	t_{CHD}		70			ns
LD setup time	t_{CHL}		200			ns
LD hold time	t_{LDC}		100			ns
LD 'H' pulse width	t_{LDH}		100			ns
Data output delay time	t_{DO}		70		350	ns
D/A output settling time	t_{LDD}				300	ns
Power-on reset level	V_{CC}		2.4	3.0	3.3	V

◆ Timing diagram

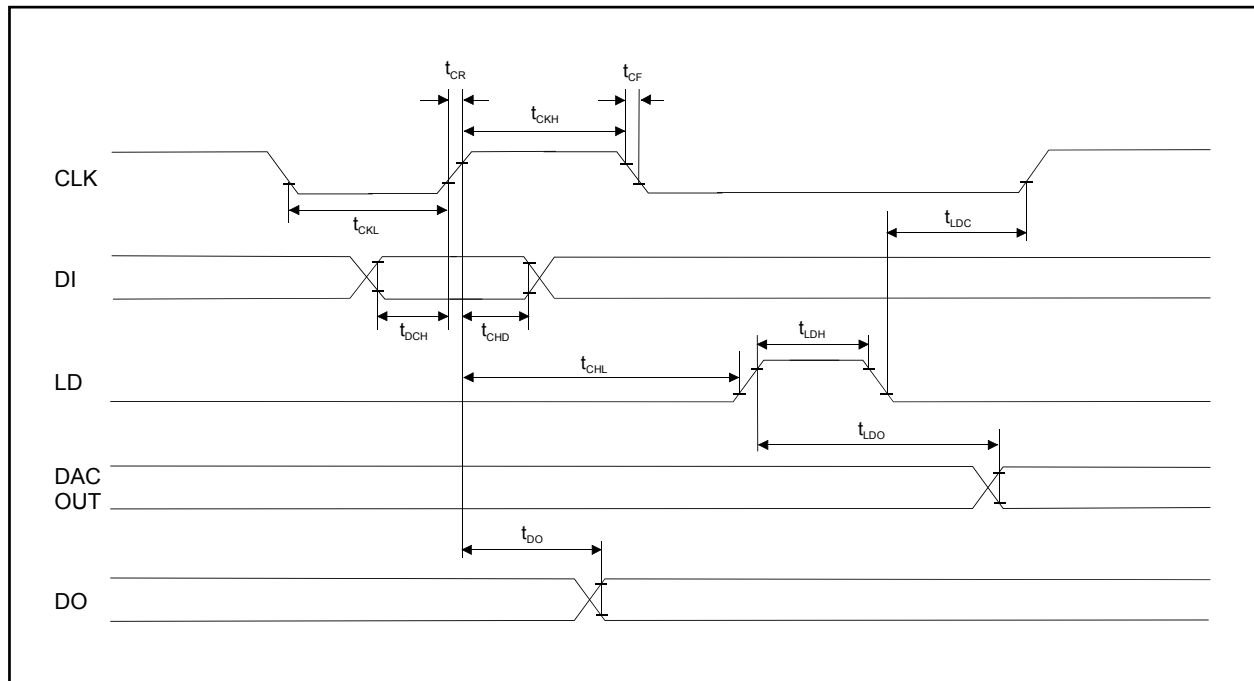

TIMING

◆ Data format

Address Data				Selected
D11	D10	D9	D8	DAC
0	0	0	0	X
1	0	0	0	DAC0
0	1	0	0	DAC1
1	1	0	0	DAC2
0	0	1	0	DAC3
1	0	1	0	DAC4
0	1	1	0	DAC5
1	1	1	0	DAC6
0	0	0	1	DAC7
1	0	0	1	DAC8
0	1	0	1	DAC9
1	1	0	1	DAC10
0	0	1	1	DAC11
1	0	1	1	X
0	1	1	1	X
1	1	1	1	X

X = Don't care condition

DAC Data								DAC Output Level
D7	D6	D5	D4	D3	D2	D1	D0	
0	0	0	0	0	0	0	0	V_{SS}
0	0	0	0	0	0	0	1	$(V_{DD}-V_{SS})/256x1+V_{SS}$
0	0	0	0	0	0	1	0	$(V_{DD}-V_{SS})/256x2+V_{SS}$
0	0	0	0	0	0	1	1	$(V_{DD}-V_{SS})/256x3+V_{SS}$
0	0	0	0	0	1	0	0	$(V_{DD}-V_{SS})/256x4+V_{SS}$
0	0	0	0	0	1	0	1	$(V_{DD}-V_{SS})/256x5+V_{SS}$
0	0	0	0	0	1	1	0	$(V_{DD}-V_{SS})/256x6+V_{SS}$
:	:	:	:	:	:	:	:	:
:	:	:	:	:	:	:	:	:
1	1	1	1	1	0	0	1	$(V_{DD}-V_{SS})/256x249+V_{SS}$
1	1	1	1	1	0	1	0	$(V_{DD}-V_{SS})/256x250+V_{SS}$
1	1	1	1	1	0	1	1	$(V_{DD}-V_{SS})/256x251+V_{SS}$
1	1	1	1	1	1	0	0	$(V_{DD}-V_{SS})/256x252+V_{SS}$
1	1	1	1	1	1	0	1	$(V_{DD}-V_{SS})/256x253+V_{SS}$
1	1	1	1	1	1	1	0	$(V_{DD}-V_{SS})/256x254+V_{SS}$
1	1	1	1	1	1	1	1	$(V_{DD}-V_{SS})/256x255+V_{SS}$

◆ Data format Timing

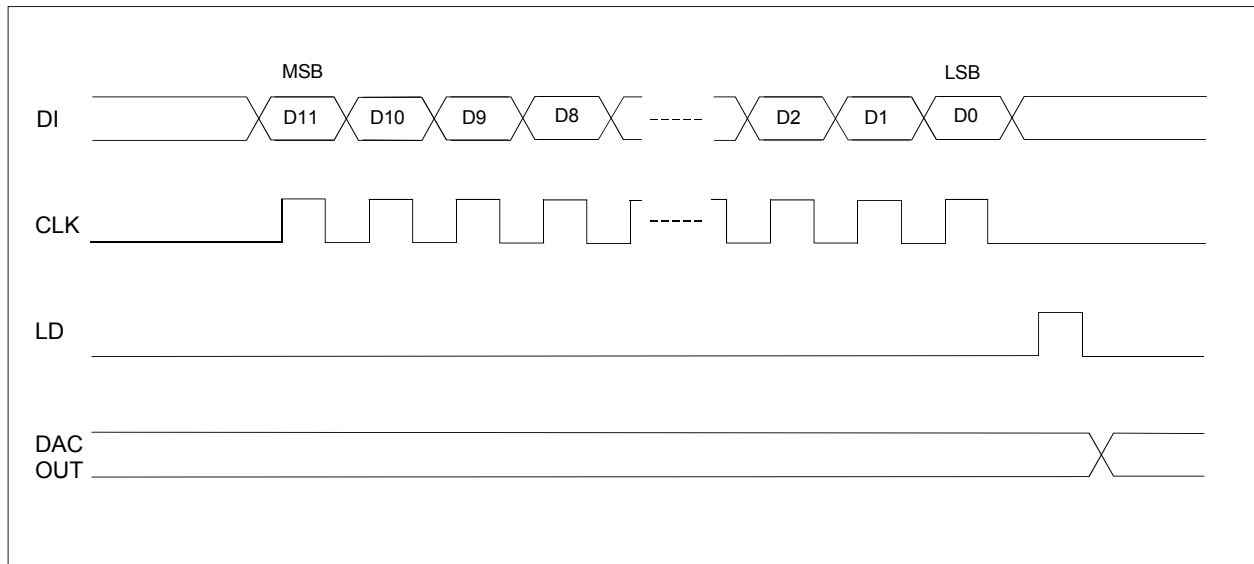

APPLICATION AND TEST CIRCUIT INFORMATION

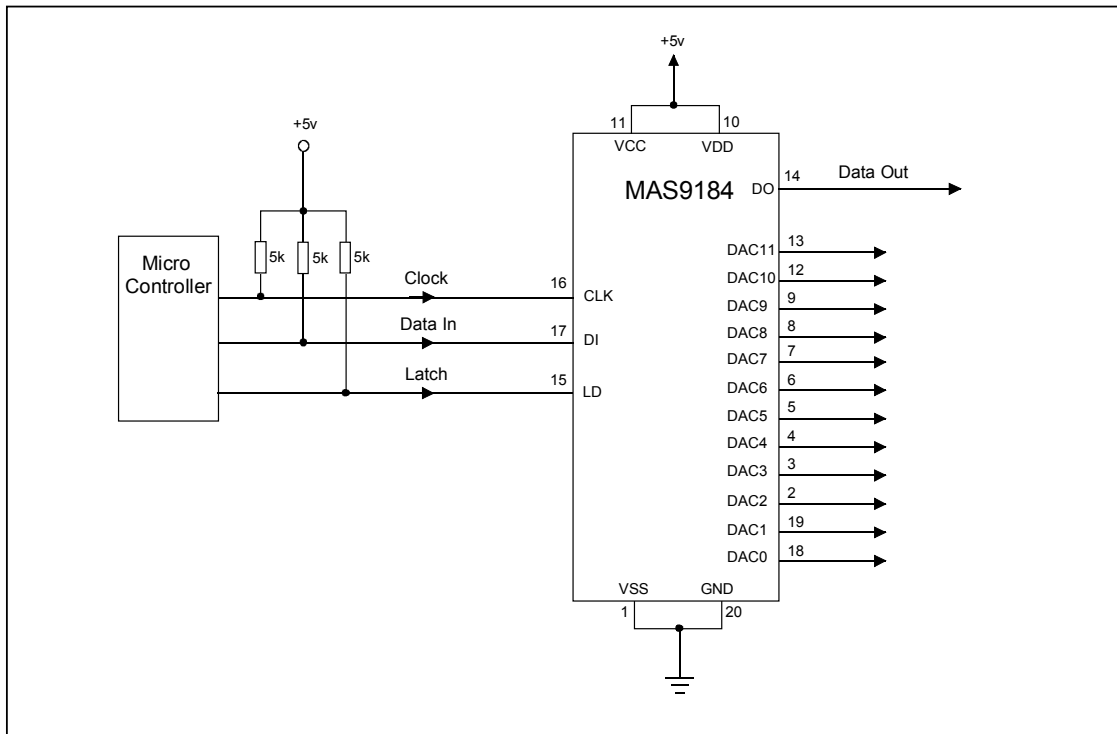

PACKAGE OUTLINES

20 LEAD SO OUTLINE (300 MIL BODY)

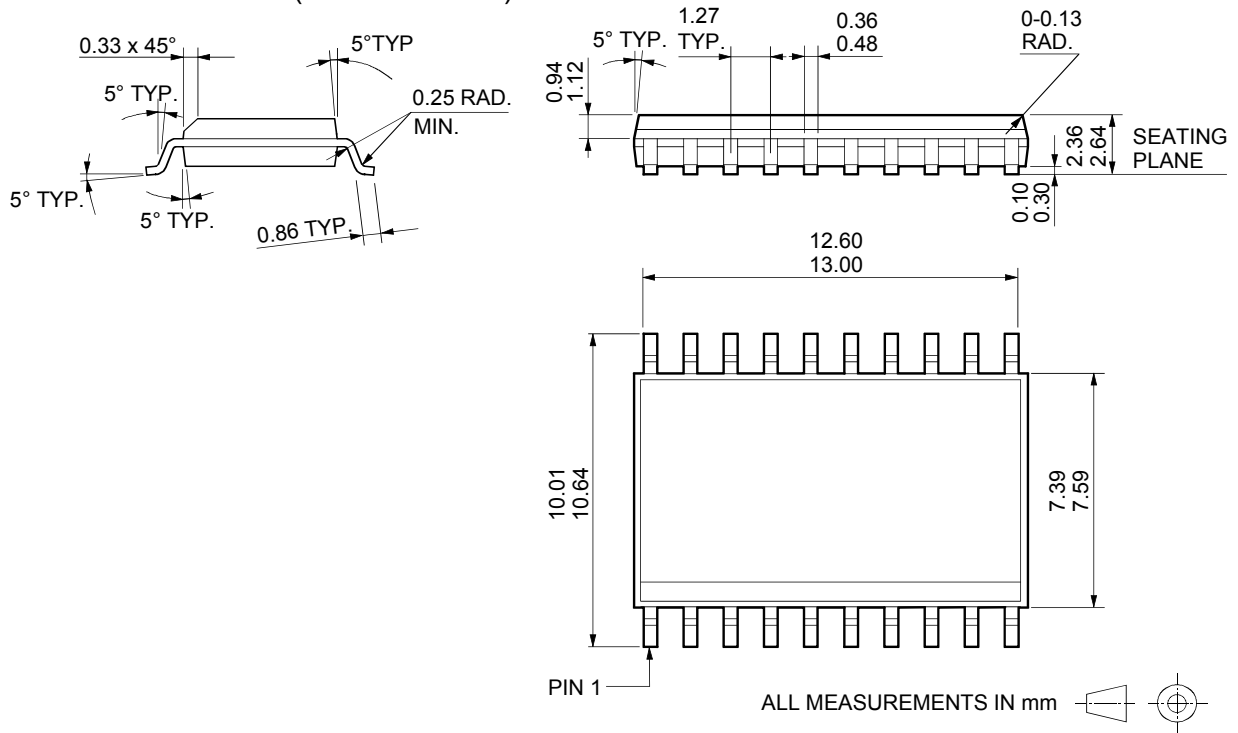

ORDERING INFORMATION

Product Code	Product	Package	Comments
MAS9184AS	12 x 8-bit D to A Converter	20 Pin SO 0.3"	
MAS9184AS-T	12 x 8-bit D to A Converter	20 Pin SO 0.3"	T&R

LOCAL DISTRIBUTOR

--

MICRO ANALOG SYSTEMS OY CONTACTS

Micro Analog Systems Oy Kamreerintie 2, P.O. Box 51 FIN-02771 Espoo, FINLAND	Tel. +358 9 80 521 Fax +358 9 805 3213 http://www.mas-oy.com
--	--

NOTICE

Micro Analog Systems Oy reserves the right to make changes to the products contained in this data sheet in order to improve the design or performance and to supply the best possible products. Micro Analog Systems Oy assumes no responsibility for the use of any circuits shown in this data sheet, conveys no license under any patent or other rights unless otherwise specified in this data sheet, and makes no claim that the circuits are free from patent infringement. Applications for any devices shown in this data sheet are for illustration only and Micro Analog Systems Oy makes no claim or warranty that such applications will be suitable for the use specified without further testing or modification.