

# RMBA09501A-58 - Cellular 2 Watt Linear GaAs MMIC Power Amplifier

ADVANCED INFORMATION

### Description

The RMBA09501A is a high power, highly linear Power Amplifier. The two stage circuit uses Raytheon RF Components' pHEMT process. It is designed for use as a driver stage for Cellular base stations, or as the output stage for Micro- and Pico-Cell base stations. The amplifier has been optimized for high linearity requirements for CDMA operation.

### Features

- ◆ 2 Watt Linear output power at 36 dBc ACPR1 for CDMA operation
- ◆ OIP3 ≥43 dBc at 27 and 30 dBm power output
- ◆ Small Signal Gain of > 30 dB
- ◆ Small outline SMD package

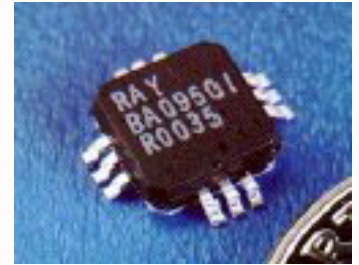

### Electrical Characteristics<sup>2</sup>

Parameter	Min	Typ	Max	Unit
Frequency Ranges	869		894	MHz
Gain (small signal)	30	35		dB
Gain variation:				
Over frequency range		+/-1.5		dB
Over temperature range		+/-2.5		dB
Noise Figure		6		dB
Output power @ CDMA <sup>3</sup>	33			dBm
OIP3 <sup>4</sup>	43	45		dBc

Parameter	Min	Typ	Max	Unit
I <sub>dd</sub> @33 dBm P <sub>out</sub> - 7V		1.0		A
PAE@33 dBm P <sub>out</sub>		28.5		%
Input VSWR (50Ω)		2:1		
Drain Voltage (V <sub>dd</sub> )		7.0		Volts
Gate Voltage (V <sub>G1</sub> , V <sub>G2</sub> ) <sup>5</sup>	-2		-0.25	Volts
Quiescent currents <sup>5</sup> (IDQ1, IDQ2)		150, 400		mA
Thermal Resistance (Channel to Case) R <sub>jc</sub>		11		°C/W

### Absolute Ratings

Parameter	Symbol	Value	Unit
Drain Supply Voltage <sup>1</sup>	V <sub>dd</sub>	+10	V
Gate Supply Voltage	V <sub>gs</sub>	-5	V
RF Input Power (from 50 Ω source)	P <sub>in</sub>	5	dBm
Operating Case Temperature	T <sub>c</sub>	-30 to +85	°C
Storage Temperature Range	T <sub>stg</sub>	-40 to +100	°C

#### Notes:

1. Only under quiescent conditions – no RF applied.
2. V<sub>DD</sub> = 7.0V, T<sub>c</sub> = 25°C. Part mounted on evaluation board with input and output matching to 50 Ohms.
3. 9 Channel Forward Link QPSK Source; 1.23 Mbps modulation rate. CDMA ACPR1 is measured using the ratio of the average power within the 1.23 MHz channel at band center to the average power within a 30 KHz bandwidth at an 885 KHz offset. Minimum CDMA output power is met with ACPR1 > 36 dBc.
4. OIP3 specifications are achieved for power output levels of 27 and 30 dBm per tone with tone spacing of 1.25 MHz at band-center.
5. V<sub>G1</sub> and V<sub>G2</sub> must be individually adjusted to achieve IDQ1 and IDQ2. A single VGG bias supply adjusted to achieve IDQTOTAL=550mA can be used with nearly equivalent performance. Values for IDQ1 and IDQ2 shown have been optimized for CDMA operation. IDQ1 and IDQ2 (or IDQTOTAL) can be adjusted to optimize the linearity of the amplifier for other modulation systems.

The device requires external input and output matching to 50 Ohms as shown in Figure 3 and the Parts List.

# RMBA09501A-58 - Cellular 2 Watt Linear GaAs MMIC Power Amplifier

ADVANCED INFORMATION

**Application Information**

**CAUTION: THIS IS AN ESD SENSITIVE DEVICE**

The following describes a procedure for evaluating the RMBA09501A-58, a monolithic high efficiency power amplifier, in a surface mount package, designed for use as a driver stage for Cellular base stations, or as the final output stage for Micro- and Pico-Cell base stations. Figure 1 shows the package outline and the pin designations. Figure 2 shows the functional block diagram of the packaged product. The RMBA09501A-58 requires external passive components for DC bias and RF input and output matching circuits as shown in Figure 3 and the Parts List. A recommended schematic circuit is shown in Figure 3. The gate biases for the two stages of the amplifier may be be set by simple resistive voltage dividers. Figure 4 shows a typical layout of an evaluation board, corresponding to the schematic circuits of figure 3. The following designations should be noted:

- (1) Pin designations are as shown in figure 1.
  - (2)  $V_{g1}$  and  $V_{g2}$  are the Gate Voltages (negative) applied at the pins of the package
  - (3)  $V_{gg1}$  and  $V_{gg2}$  are the negative supply voltages at the evaluation board terminals
  - (4)  $V_{d1}$  and  $V_{d2}$  are the Drain Voltages (positive) applied at the pins of the package
  - (5)  $V_{dd1}$  and  $V_{dd2}$  are the positive supply voltages at the evaluation board terminals
- Note: The 2 terminals of  $V_{dd1}$  and  $V_{dd2}$  may be tied together.  
The base of the package must be soldered on to a heat sink for proper operation.

**Figure 1**  
Package Outline and Pin Designations

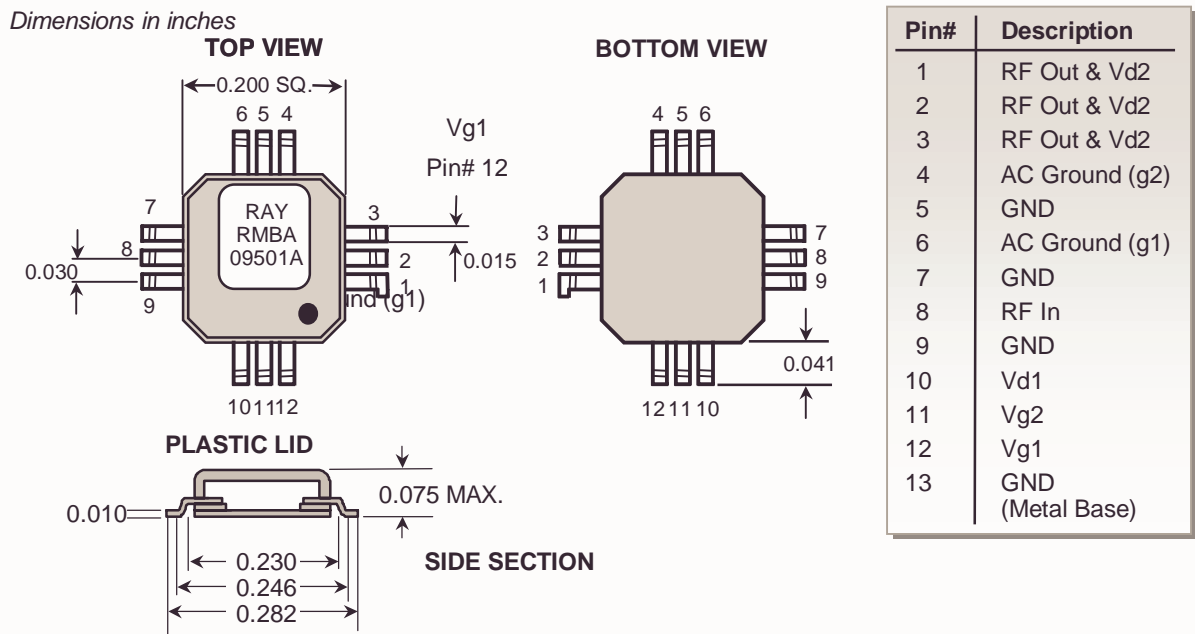

**Figure 2**  
Functional Block Diagram

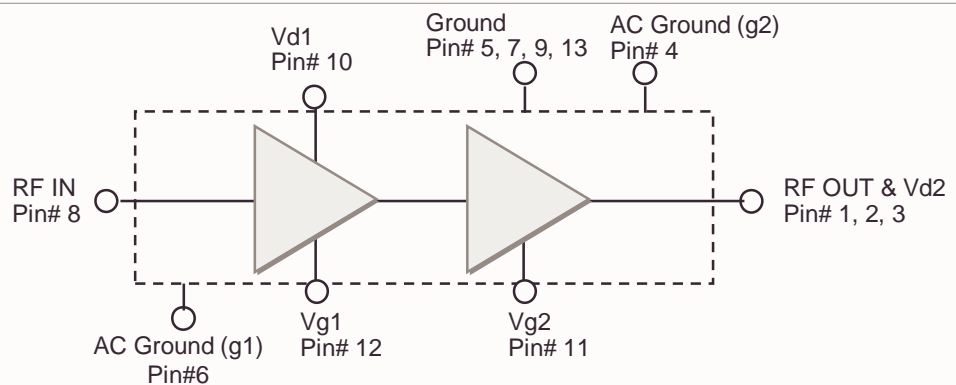

# RMBA09501A-58 - Cellular 2 Watt Linear GaAs MMIC Power Amplifier

ADVANCED INFORMATION

**Figure 3**

Schematic for a Typical Test Evaluation Board (RMBA09501A-58-TB)

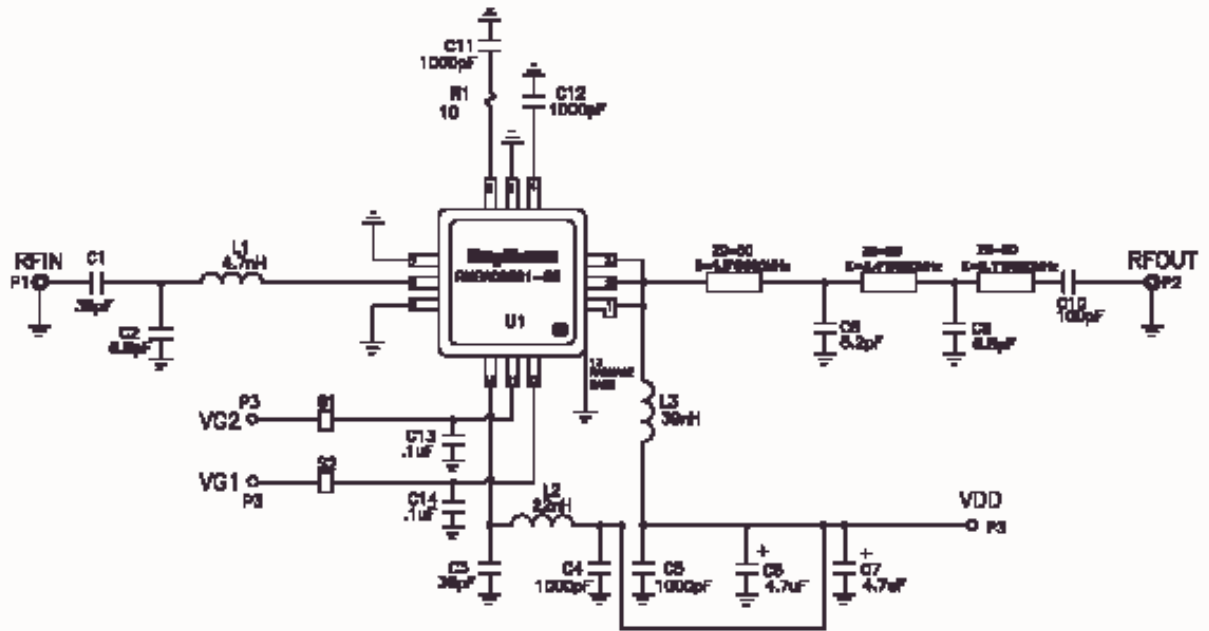

**Figure 4**

Layout and Assembly of Test Evaluation Board (RMBA09501A-58-TB, G657471)

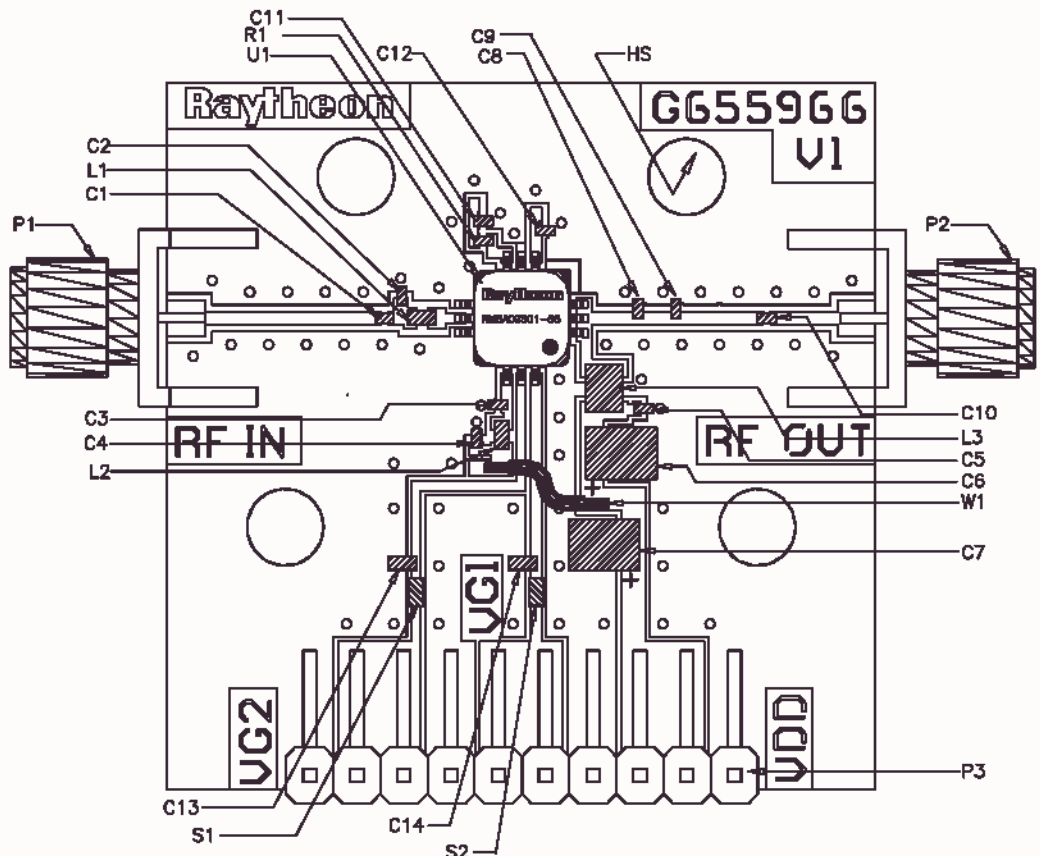

# RMBA09501A-58 - Cellular 2 Watt Linear GaAs MMIC Power Amplifier

ADVANCED INFORMATION

### Test Procedure

for the evaluation board (RMBA09501A-58-TB)

**CAUTION: LOSS OF GATE VOLTAGES (Vg1, Vg2) WHILE CORRESPONDING DRAIN VOLTAGES (Vdd) ARE PRESENT CAN DAMAGE THE AMPLIFIER.**

The following sequence must be followed to properly test the amplifier. (It is necessary to add a fan to provide air cooling across the heat sink of RMBA09501A.) Note: Vdd1, 2 are tied together.

**Step 1:** Turn off RF input power.

**Step 2:** Use GND terminal of the evaluation board for the ground of the DC supplies. Slowly apply gate supply voltages as specified on results sheet supplied with test board to the board terminals Vgg1 and Vgg2.

**Step 3:** Slowly apply drain supply voltages of +7.0 V to the board terminals Vdd1, 2. Adjust Vgg to set the total quiescent current (with no RF applied) Idq as per supplied result sheet. [Gate supply voltages (Vgg i.e., Vgg1, Vgg2) may be adjusted, only if quiescent current (Idq1 and Idq2) values desired are different from those noted on the data summary supplied with product samples].

**Step 4:** After the bias condition is established, RF input signal may now be applied at the appropriate frequency band and appropriate power level.

**Step 5:** Follow turn-off sequence of:

- (i) Turn off RF Input Power
- (ii) Turn down and off drain voltages Vdd1, 2.
- (iii) Turn down and off gate voltages Vgg1 and Vgg2.

### Parts List

for Test Evaluation Board (RMBA09501A-58-TB)

Part	Value	EIA Size	Vendor(s)
C1,C3	39 pF	0402	Murata, GRM36COG390J050
C2,C9	6.8 pF	0402	Murata, GRM36COG6R8B050
C8	8.2 pF	0402	Murata, GRM36COG8R2B50
C4,C5,C11,C12	1000 pF	0402	Murata, GRM36X7R102K050
C6,C7	4.7 uF	3528	TDK, C3216X7R102K050
L1	4.7 nH	0603	Toko, LL1608-FH4N7S
L2	22 nH	0603	Toko, LL1608-FH22NK
L3	39 nH	1008	Coilcraft, 1008HQ-39NTKBC
R1	10 Ohm	0402	IMS, RCI-0402-10R0J
S1, S2			Bar or Ni Ribbon Short
W1	26AWG (0.015" dia) Wire		Alpha, 2853/1
U1	RMBA09501-58 PA		Raytheon
P3	Right angle Pin Header		3M 2340-5211TN
P1,P2	Brass SMA Connectors		Johnson Components 142-0701-841
Board	FR4		Raytheon Dwg# G654626, V1
C10	100 pF	0603	Murata, GRM36COG101J50
C13, C14	1.0 uF	0805	Murata, GRM39Y5V104Z50

### Thermal Considerations for Heat Sinking the RMBA09501A-58

The PWB must be prepared with either an embedded copper slug in the board where the package is to be mounted or a heat sink should be attached to the backside of the PWB where the package is to be mounted on the front side. The slug or the heat sink should be made of a highly electrically and thermally conductive material such as copper or aluminum. The slug should be at least the same thickness as the PWB. In the case of the heat sink, a small pedestal should protrude through a hole in the PWB where the package bottom is directly soldered. In either configuration, the top surface of the slug or the pedestal should be made coplanar with the package lead mounting plane i.e., the top surface of the PWB. Use Sn96 solder (96.5% Sn and 3.5% Ag) at 220°C for 20 seconds or less to attach the heat sink to the backside of the PWB. Then, using Sn63, the package bottom should be firmly soldered to the slug or the pedestal while the pins are soldered to the respective pads on the front side of the PWB without causing any stress on the pins. Remove flux completely if used for soldering.