

SMP402

1-Watt Buck Regulator IC

20-72 VDC Input

Non-isolated DC Output



Product Highlights

Integrated Power Switch and CMOS Controller

- Output power > 1 W from 48 VDC input
- Adjustable output voltage
- Integrated solution minimizes overall size

High-voltage, Low-capacitance MOSFET Output

- Designed for ISDN T1 telecommunications applications
- Low capacitance allows for high frequency operation

High-voltage Buck Regulator

- Internal pre-regulator self-powers the IC on start-up
- Designed for low power consumption
- Minimum external parts required

Built-In Self-protection Circuits

- Undervoltage lockout
- Thermal shutdown
- Input polarity/level sense

Description

The SMP402, intended for non-isolated ISDN telecommunications power supply applications, combines a high voltage power MOSFET switch with a switchmode power system controller in a monolithic integrated circuit. Few external components are required to implement a low cost power supply which meets stringent ISDN specifications. High frequency operation reduces total power supply size.

The P-channel power MOSFET switch features include high voltage, low $R_{DS(ON)}$, and low capacitance. Lower capacitance results in a reduction in gate drive power, and also facilitates higher frequency operation.

The controller section of the SMP402 contains all the blocks required to drive and control the power stage: start-up pre-regulator circuit, oscillator, bandgap reference, error amplifier, gate driver and level shift. Protection features include undervoltage lockout, thermal shutdown, and input polarity and level sensing.

The SMP402 is available in a 16-pin plastic SOIC package.

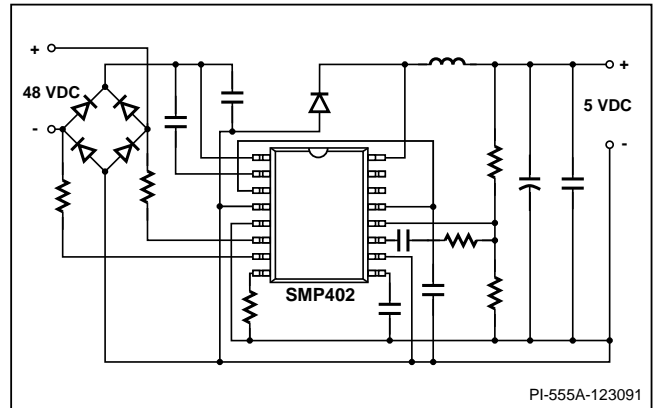

Figure 1. Typical Application.

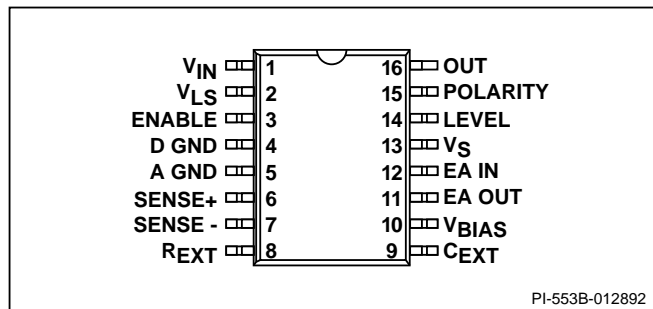

Figure 2. Pin Configuration.

ORDERING INFORMATION		
PART NUMBER	PACKAGE OUTLINE	T _J RANGE
SMP402SC	S16A	0 to 120°C

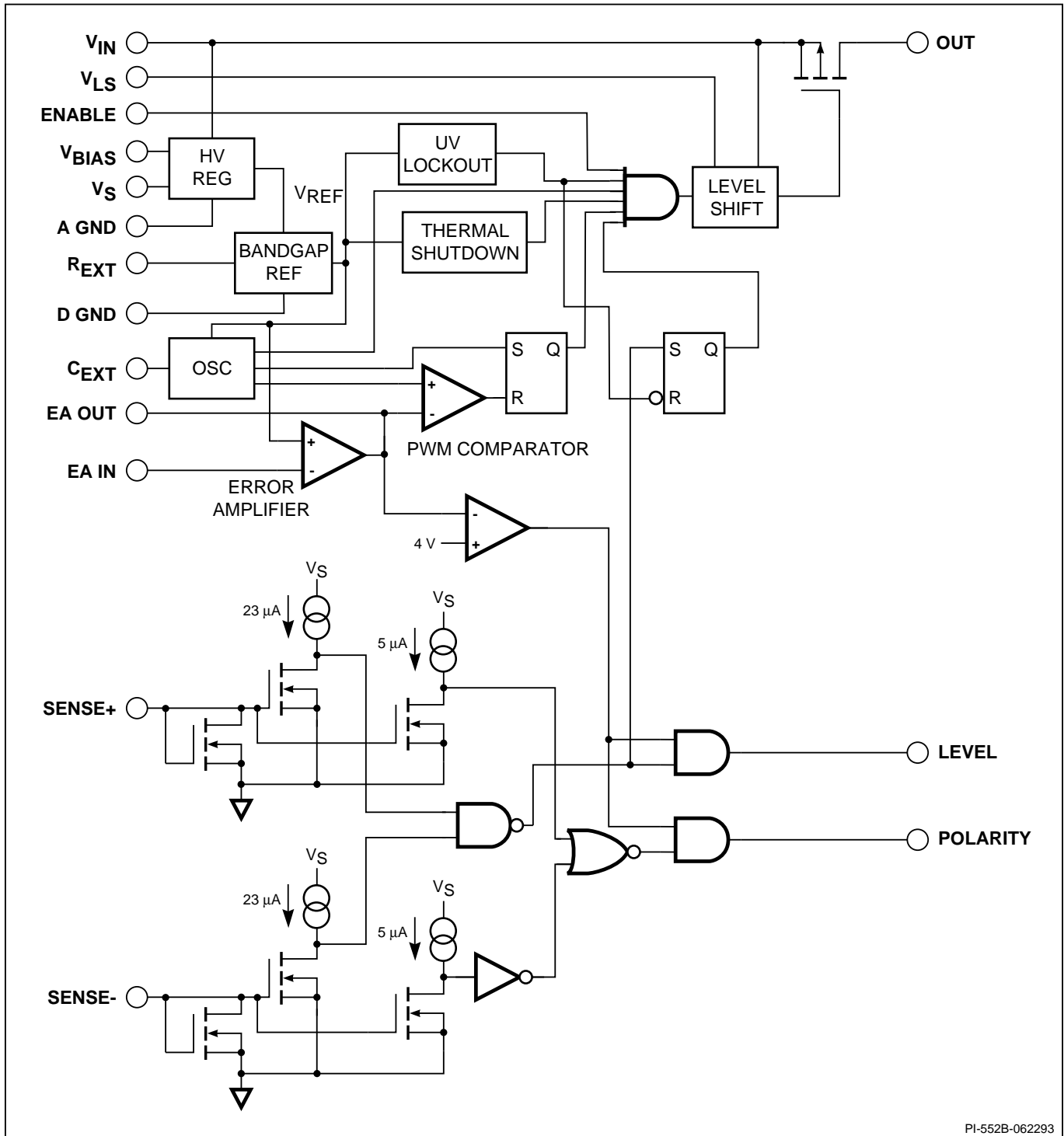

Figure 3. Functional Block Diagram.

Pin Functional Description

Pin 1:

V_{IN} is the high-voltage input to the switching regulator. This is the Source connection of the P-Channel power MOSFET pass transistor.

Pin 2:

V_{LS} is an internal supply for the level shift circuit that drives the P-Channel MOSFET. A capacitor should be placed between V_{LS} and V_{IN} for bypassing. V_{LS} is normally 10 V below V_{IN} .

Pin 3:

The power supply can be shut down by pulling **ENABLE** low.

Pin 4:

D GND is the common return point for the power and logic portions of the circuit.

Pin 5:

A GND is the common return point. R_{EXT} and C_{EXT} are directly connected to this point.

Pin 6:

The **SENSE+** input monitors the polarity and level of the input voltage through an external resistor for ISDN emergency standby sensing.

Pin 7:

The **SENSE-** input monitors the polarity and level of the input voltage through an external resistor for ISDN emergency standby sensing.

Pin 8:

A 20.5 k Ω resistor connected between R_{EXT} and A GND sets the internal bias currents including oscillator charge and discharge currents.

Pin 9:

The oscillator frequency can be programmed by selecting the value of the capacitor connected between C_{EXT} and A GND.

Pin 10:

V_{BIAS} can be connected to the output 5 V rail of the converter to reduce power dissipation. The internal 5 V regulator is cut off when the output is in regulation.

Pin 11:

EA OUT is the error amplifier output pin for connection to the external compensation network.

Pin 12:

EA IN is the error amplifier negative input for connection to the feedback and compensation networks.

Pin 13:

V_S is the internal supply voltage. This pin is brought out for external bypassing.

Pin 14:

The **LEVEL** output indicates when the input voltage is in its normal operating range.

Pin 15:

The **POLARITY** output is used to notify a microprocessor of an emergency standby condition for ISDN applications.

Pin 16:

OUT is the Drain connection of the P-Channel pass transistor.

Functional Description

High Voltage Regulator

The high-voltage regulator provides the bias current required by the controller and driver circuitry. The pre-regulator consists of a high voltage MOSFET, a gate bias current source, and an error amplifier. The error amplifier regulates V_S to approximately 5 V by controlling the gate of the MOSFET.

In 5 V output applications, the control circuitry may also be operated by connecting the V_{BIAS} pin to the output 5 V rail of the converter to reduce power dissipation. The internal 5 V regulator is cut off automatically when the converter output is in regulation. Only the supply

current for the level shift stage ($\approx 50 \mu\text{A}$) and the AC switching currents for the P-Channel output device are drawn from the V_{IN} supply under this condition. If unused, V_{BIAS} must be hardwired to A GND to disable the automatic switchover during power-up.

V_{LS} is the level-shift supply for driving the gate of the internal P-channel MOSFET. The voltage at V_{LS} is approximately 10 V below V_{IN} . V_S is the supply voltage for the controller and driver circuitry. External bypass capacitors connected to V_{LS} and V_S are required for filtering and reducing noise.

UV Lockout

During power-up, the undervoltage lockout circuit keeps the P-channel output transistor in the off state until the internal V_S supply is in regulation and the voltage sensed by the input monitor circuit is within the normal operation range ($>12 \text{ V}$).

Band Gap Reference

V_{REF} is the 1.3 V reference voltage generated by the temperature-compensated bandgap reference and buffer. This voltage is used for setting thresholds for the error amplifier and over temperature circuit.



Functional Description (cont.)

Oscillator

The oscillator frequency can be adjusted by changing the external C_{EXT} capacitor. This capacitor is charged and discharged by switched constant current sources.

The voltage switch points are determined by hysteresis built into a comparator. The period of the waveform is determined by values of the current sources which set the rising and falling slopes of the sawtooth waveform. Maximum duty cycle is equal to the ratio of the charge time to the period. Clock and blanking signals are synthesized from the comparator output for use by the modulator.

Error Amplifier

The error amplifier consists of a high performance operational amplifier with the non-inverting input connected to the internal bandgap reference voltage. The output of the error amplifier directly controls the duty cycle of the power switch.

Pulse Width Modulator

The pulse width modulator implements a voltage-mode control loop, and generates the digital driver signal which controls the power switch. The duty cycle of the driver signal will change as a function of input voltage and load. Increasing the duty cycle causes the power supply output voltage to go up. Conversely, decreasing the duty cycle causes the output voltage to go down. The pulse width modulator compares the control voltage (error amplifier output) with the sawtooth voltage generated by the oscillator to produce the required duty cycle.

Thermal Shutdown

Temperature protection is provided by a precision analog circuit that turns the power switch off when the junction gets too hot (typically 140°C). The device will automatically reset and turn back on again when the junction has cooled past the hysteresis temperature level.

SENSE+ and SENSE- Inputs

SENSE+ and SENSE- are both current mirror inputs consisting of N-channel MOSFETs connected as diodes. The threshold voltage of each transistor is typically 1.7 V. An input current which exceeds the indicated threshold current will turn on the mirror transistor for an active-low signal.

POLARITY and LEVEL Outputs

The LEVEL output is high when the input current to either SENSE+ or SENSE- exceeds the LEVEL current threshold and the output voltage is in regulation. During normal operation, the POLARITY output is high when the input current to SENSE+ is above the POLARITY current threshold and the output voltage is in regulation. During emergency operation (when the DC input voltage is inverted), the POLARITY output is low when the input current to SENSE- exceeds the

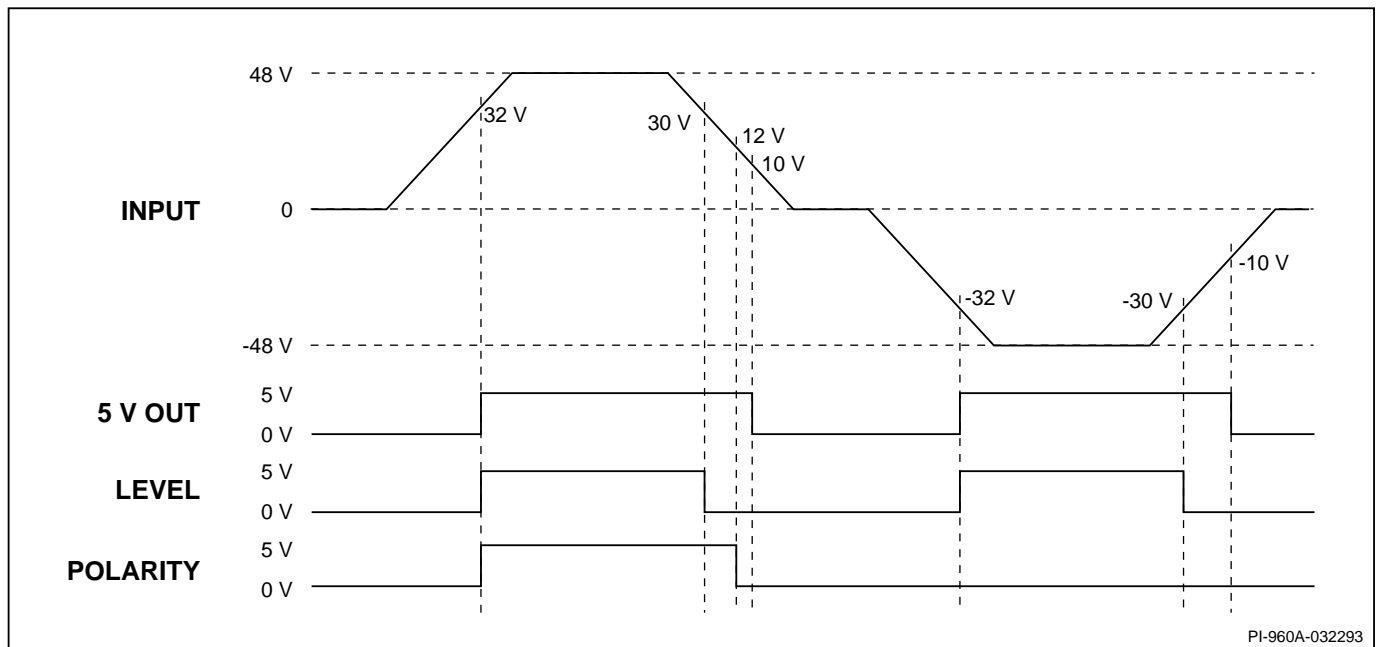

Figure 4. Turn-on and Turn-off Waveforms of the SMP402.

Functional Description (cont.)

POLARITY current threshold. Regulation of the output voltage is detected by a comparator which looks for error amplifier saturation in the output high (maximum duty cycle) state.

Power supply turn on and turn off with a slowly changing input voltage is shown in Figure 4 as measured using the circuit shown in Figure 6. Also shown are the level and polarity outputs. The input voltage must rise above 32 V before the SMP402 will turn on. At this input voltage the current through R1 into the SENSE+ input exceeds the threshold current (typically 23 μ A), the LEVEL and POLARITY outputs go high, and

the power supply turns on. As the input voltage goes down, LEVEL will go low at approximately 30 V, but POLARITY will stay high. As the input voltage continues to drop, POLARITY goes low at approximately 12 V and the converter loses regulation at approximately 10 V and turns off. The LEVEL output will go high and the power supply turns on when the input voltage reaches -32 V. POLARITY stays low to indicate that the input voltage has reversed polarity. As the negative input voltage falls toward zero, LEVEL goes low at approximately -30 V and the converter loses regulation and turns off at approximately -10 V.

Enable

The power supply can be shut down by pulling the ENABLE pin low. It is internally pulled up to V_S with a 100 μ A (nominal) current source. However, it is recommended that this pin be tied to V_S if it is unused.

P-Channel Output Transistor

The output MOSFET is a 90 V pass transistor capable of supplying >200 mA. To minimize switching noise and EMI, it is important to keep the path from OUT through the output diode, the input storage capacitor, and into V_{IN} as short as possible.

INPUT VOLTAGE CONDITION	POLARITY	LEVEL
Negative voltage, level too low	0	0
Negative voltage, correct level	0	1
Positive voltage, level too low	1	0
Positive voltage, correct level	1	1

Figure 5. LEVEL/POLARITY Truth Table. The LEVEL and POLARITY signals are only valid when the output voltage is in regulation.

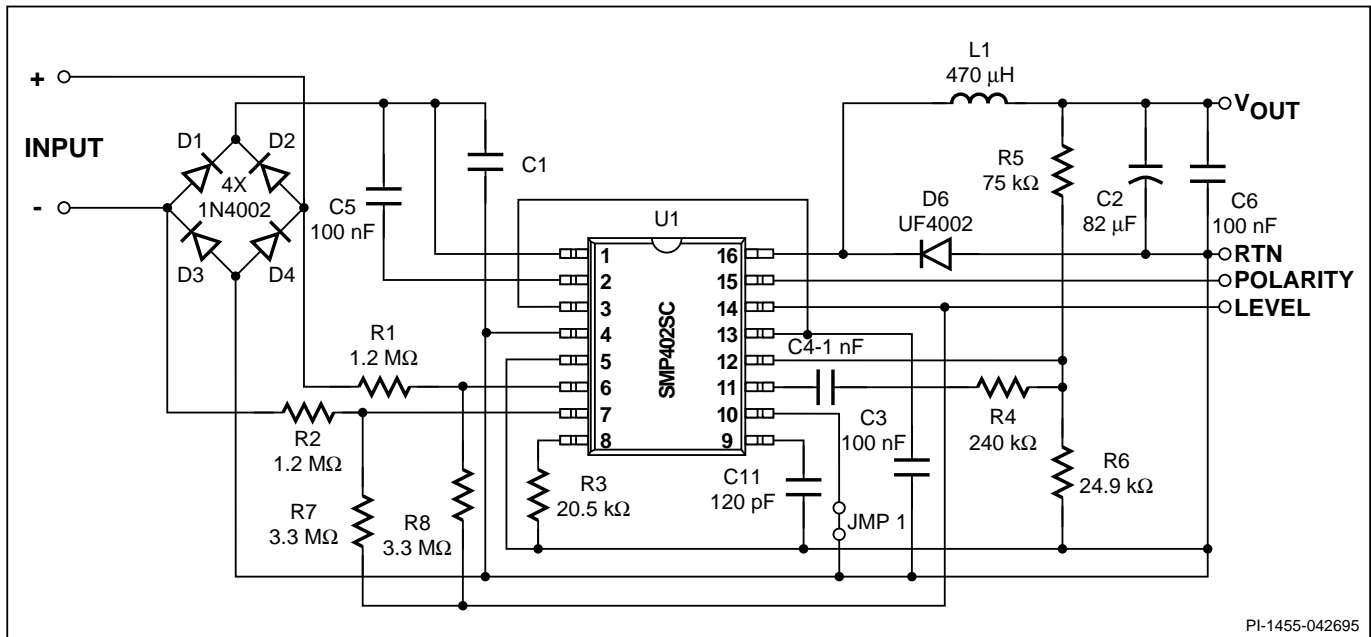

Figure 6. Schematic Diagram of a Non-isolated 5 V, 1 W ISDN Regulator Circuit Utilizing the SMP402.

General Circuit Operation

The Buck DC-to-DC converter shown in Figure 6 produces a single non-isolated 5 V, 1 W power supply. The high-voltage P-channel MOSFET transistor in the SMP402 is turned on and off at the switching frequency. The ratio of ON-time to the switching period is defined as the duty cycle. The duty cycle changes with input voltage to maintain a constant average value of the switching waveform. The switching waveform is filtered by inductor L1 and capacitor C2 to produce the 5 V output. During the MOSFET ON-time, the switch current and inductor current ramp up at a linear rate. During the P channel MOSFET switch off time, the voltage across L1 reverses, forward biasing D6. Inductor and diode current then ramp down linearly until the MOSFET turns on again. During normal operation, inductor current ramps up and down around the average value (I_{OUT}), which is actually the DC load current.

The 5 V output voltage is directly sensed and accurately regulated by an internal error amplifier. The error amplifier generates an error signal which directly controls the duty cycle of the integrated high-voltage P-channel MOSFET switch. The effective output voltage can be fine-tuned by adjusting the resistor divider formed by R5 and R6. Other output voltages are possible (up to approximately half the input voltage) by changing the value of L1 as well as the resistor divider.

Polarity of the DC input voltage can be either positive or negative. D1, D2, D3, and D4 “rectify” the DC input voltage to provide a positive polarity input voltage for the converter. C1 provides input voltage filtering. The SMP402 contains the integrated controller and high-voltage P-channel MOSFET which, together with D6, generates a pulse width modulated switching AC voltage waveform. L1 and C2 filter the AC voltage to create the 5 V output. C6 filters high-frequency noise currents. R5 and R6 sense and divide the 5 V output voltage for comparison with the internal

bandgap reference voltage. C4 and R4 provide control loop compensation feedback around the internal error amplifier. C3 bypasses the onboard V_s regulator. C11 sets the switching frequency. R3 is fixed to set internal currents accurately. C5 bypasses an internally-generated, level-shifted bias source of approximately 10 V, which is referenced to the positive side of the effective input voltage. This floating supply is used for biasing the P-channel MOSFET gate drivers. R1 and R2 sense the level and polarity of the DC input voltage. The current through R1 and the SENSE+ input or R2 and the SENSE- input must exceed 23 μ A before the converter will turn on. R7 and R8 provide hysteresis for the SENSE+ and SENSE- inputs. Jumper JMP1 disables the self-bias feature of the SMP402.

General Circuit Operation (cont.)

The line and load regulation graphs were measured on the circuit shown in Figure 6. The switching frequency of the power supply was measured at 230 kHz.

The maximum output power curve shows

the power output capability for a 470 μH output filter inductor (L1).

The output power versus frequency curve was generated by characterization of the SMP402 at various frequencies. The

curve demonstrates the trade-off between AC and DC power losses within the device. As AC losses rise with frequency, DC losses and output power must be reduced to maintain the same device maximum power dissipation.

Typical Performance Characteristics (Figure 6 Power Supply)

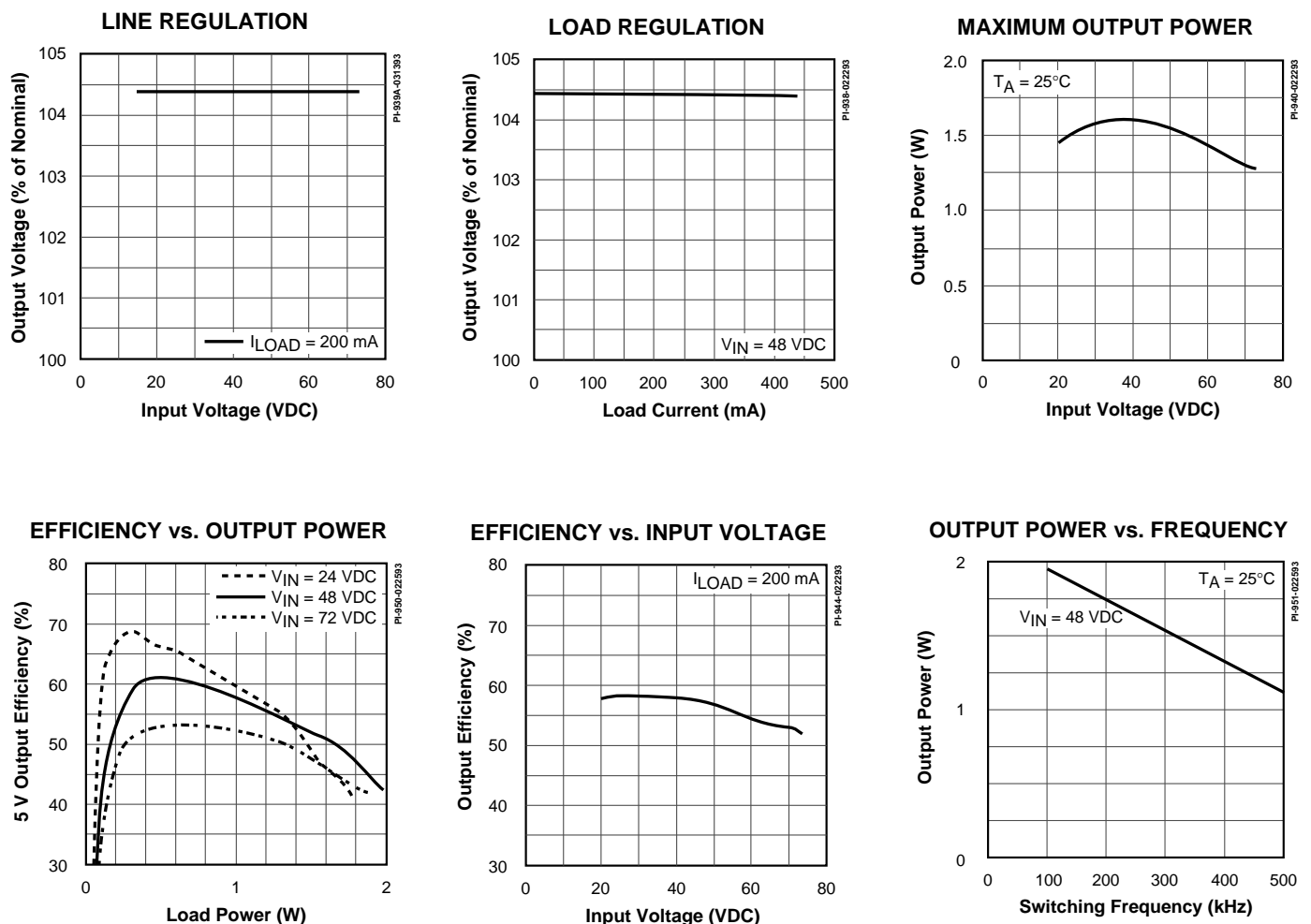

ABSOLUTE MAXIMUM RATINGS¹

V _{IN} Voltage 80 V	Lead Temperature ⁽³⁾ 260°C
Drain-Source Voltage (V _{IN} to OUT) 90 V	Power Dissipation 1.0 W
V _{BIAS} Voltage 5.5 V	Thermal Impedance (θ _{JA}) 55°C/W
SENSE Current ±200 μA	Thermal Impedance (θ _{JC}) ⁽⁴⁾ 15°C/W
OUT Voltage V _{IN} + 0.3 V to -4 V	
OUT Current 250 mA	1. Unless noted, all voltages referenced to A GND, T _A = 25°C
Logic Input Voltage -0.3 V to V _S + 0.3 V	2. Normally limited by internal circuitry.
Storage Temperature -65 to 125°C	3. 1/16" from case for 5 seconds.
Operating Junction Temperature ⁽²⁾ 0 to 150°C	4. Measured at pin 4/5.

Parameter	Symbol	Conditions	Min	Typ	Max	Units
		(Unless Otherwise Specified) V _{IN} = 48 V, V _{BIAS} = 5 V, GNDs = 0 V R _{EXT} = 20.5 kΩ, C _{EXT} = 120 pF R _{S+} , R _{S-} = 1.2 MΩ, T _j = 0 to 120°C				
OSCILLATOR						
Output Frequency	f _{OSC}	C _{EXT} = 30 to 300 pF	50		500	kHz
Initial Accuracy	Δf _{OSC}		200	230	260	kHz
PULSE WIDTH MODULATOR						
Duty Cycle	DC		0-50	0-70		%
ERROR AMPLIFIER						
Threshold Voltage	V _{REF}		1.22		1.32	V
Gain-Bandwidth Product				0.5		MHz
DC Gain	A _{VOL}		60	80		dB
Common-mode Range	V _{EA IN}	See Note 2	0		3	V
Output Impedance	Z _{OUT}			1		kΩ



Parameter	Symbol	Conditions		Min	Typ	Max	Units
		(Unless Otherwise Specified) $V_{IN} = 48\text{ V}$, $V_{BIAS} = 5\text{ V}$, $GNDs = 0\text{ V}$ $R_{EXT} = 20.5\text{ k}\Omega$, $C_{EXT} = 120\text{ pF}$ R_{S+} , $R_{S-} = 1.2\text{ M}\Omega$, $T_j = 0\text{ to }120^\circ\text{C}$					
CIRCUIT PROTECTION							
Thermal Shutdown Temperature		$V_{IH} = 3.0\text{ V}$		120	140		$^\circ\text{C}$
Thermal Shutdown Hysteresis		$V_{IL} = 0\text{ V}$			15		$^\circ\text{C}$
LOGIC							
Input Current High	I_{IH}				10	50	μA
Input Current Low	I_{IL}			-500	-100		μA
Input Voltage High	V_{IH}					3.0	V
Input Voltage Low	V_{IL}			1.0			V
Output Voltage High	V_{OH}	$I_{OH} = -0.5\text{ mA}$		3.5			V
Output Voltage Low	V_{OL}	$I_{OL} = 0.5\text{ mA}$				0.4	V
SENSE INPUTS							
Threshold Voltage	$V_{SENSE+/-}$				1.7	2.2	V
LEVEL Threshold Current	I_{LEVEL}			21	24	27	μA
POLARITY Threshold Current	$I_{POLARITY}$				5	7	μA
OUTPUT							
ON-State Resistance	$R_{DS(ON)}$	$I_{OUT} = -100\text{ mA}$	$T_j = 25^\circ\text{C}$			12	Ω
			$T_j = 100^\circ\text{C}$			20	
ON-State Current	$I_{D(ON)}$	$V_{DS} = 5\text{ V}$ See Note 1	$T_j = 25^\circ\text{C}$	200	500		mA
			$T_j = 100^\circ\text{C}$	100	350		

Parameter	Symbol	Conditions	Min	Typ	Max	Units
		(Unless Otherwise Specified) $V_{IN} = 48\text{ V}$, $V_{BIAS} = 5\text{ V}$, $GNDs = 0\text{ V}$ $R_{EXT} = 20.5\text{ k}\Omega$, $C_{EXT} = 120\text{ pF}$ $R_{S+}, R_{S-} = 1.2\text{ M}\Omega$, $T_j = 0\text{ to }120^\circ\text{C}$				
OUTPUT (cont.)						
OFF-State Current	I_{DSS}	$V_{IN} = 72\text{ V}$, $OUT = 0\text{ V}$, $T_A = 120^\circ\text{C}$	-50	-10		μA
Breakdown Voltage	BV_{DSS}	$I_{OUT} = -250\text{ }\mu\text{A}$, $T_A = 25^\circ\text{C}$	90			V
SUPPLY						
HV Regulator Voltage	V_{IN}		12		72	V
Off-line Supply Current	I_{IN}	$V_{BIAS} = A\text{ GND}$		1.5	2.5	mA
		$V_{BIAS} = 5\text{ V}$		1	1.5	
V_{BIAS} Supply Voltage	V_{BIAS}		4.75		5.25	V
V_{BIAS} Supply Current	I_{BIAS}			1	1.5	mA

NOTES:

- At low output currents (< 20 mA), the part may operate in blocking oscillation mode, resulting in large output ripple.
- Applying >3.5 V to the EA IN pin activates an internal test circuit that turns on the output switch continuously. Destruction of the part can occur if the output of the SMP402 is connected to a high voltage power source when the test circuit is activated.

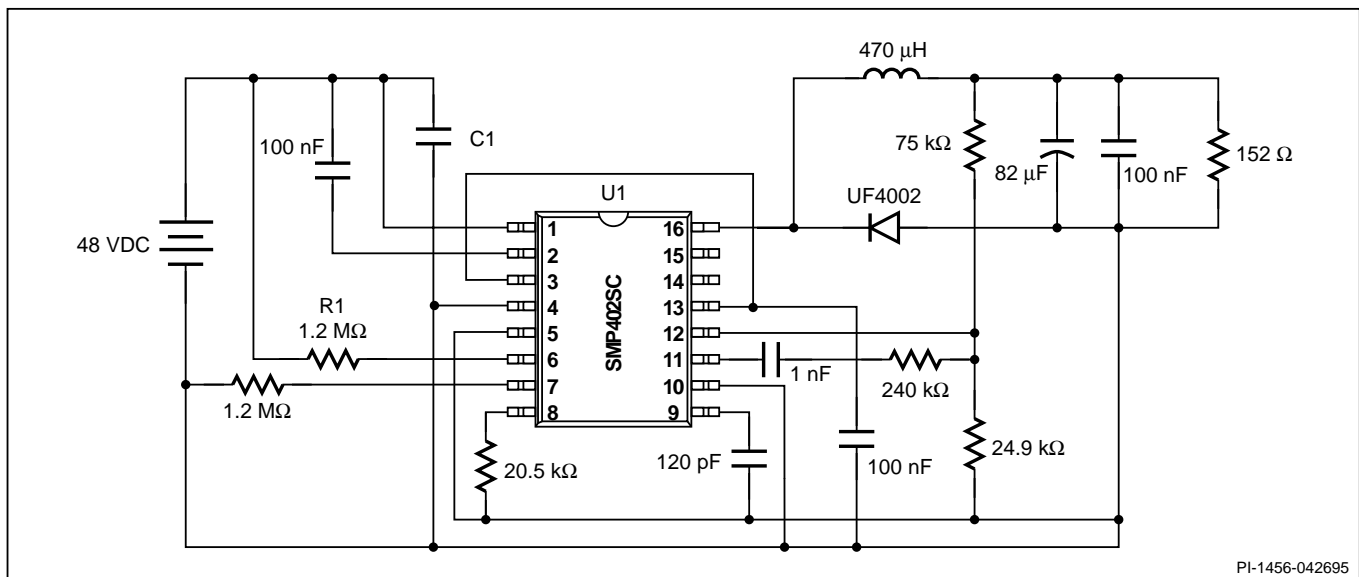

PI-1456-042695

Figure 7. Switching Time Test Circuit.

BREAKDOWN vs. TEMPERATURE

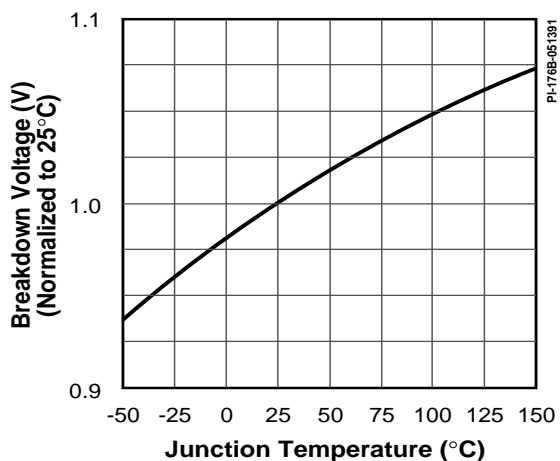

fPWM vs. EXTERNAL CAPACITANCE

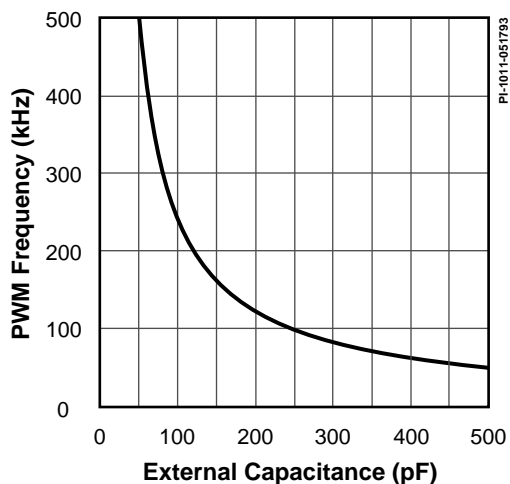

C_{oss} vs. DRAIN VOLTAGE

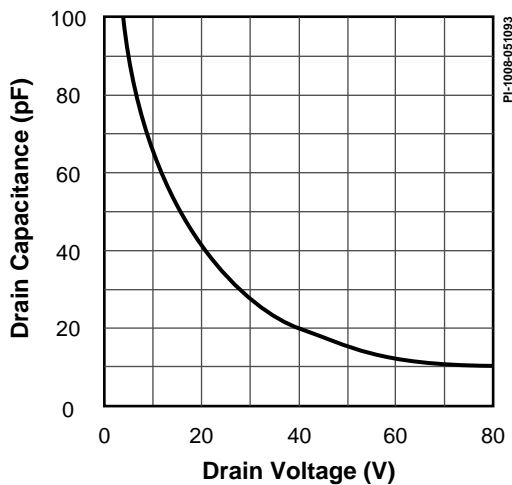

DRAIN CHARGE vs. DRAIN VOLTAGE

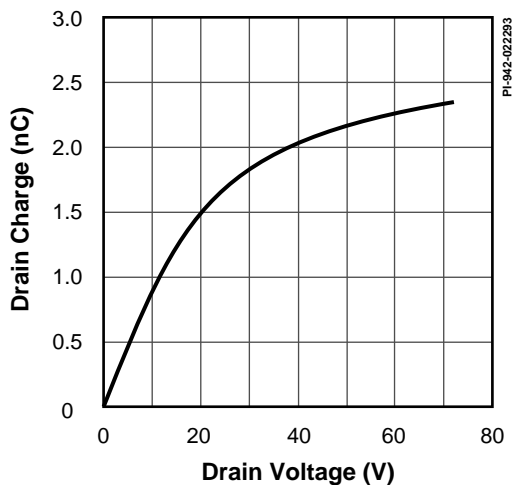

DRAIN CAPACITANCE ENERGY

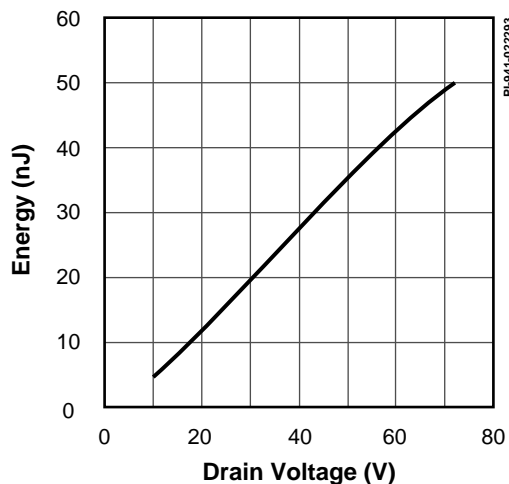

PACKAGE POWER DERATING

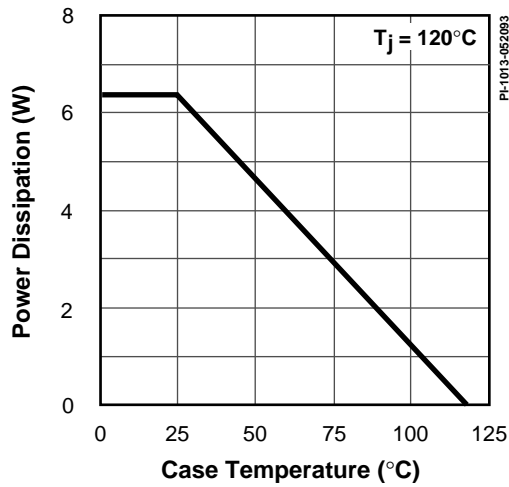

TRANSIENT THERMAL IMPEDANCE

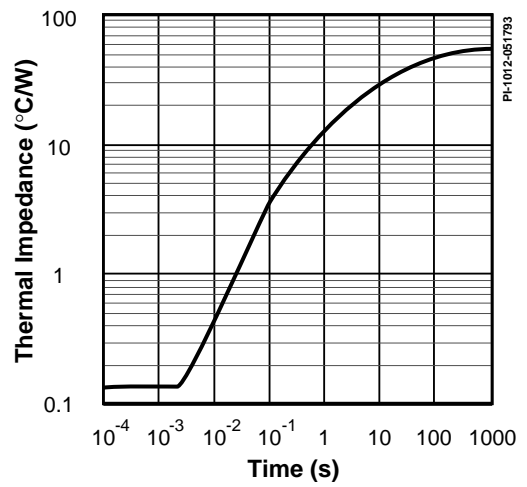

S16A

Plastic SO-16 (W)

DIM	inches	mm
A	.398-.413	10.10-10.50
B	.050 BSC	1.27 BSC
C	.014-.018	0.36-0.46
E	.093-.104	2.35-2.65
F	.004-.012	0.10-0.30
J	.394-.418	10.01-10.62
L	.009-.012	0.23-0.32
M	.020-.040	0.51-1.02
N	.291-.299	7.40-7.60

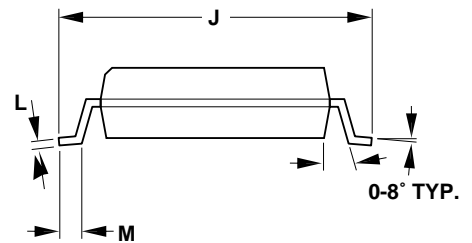
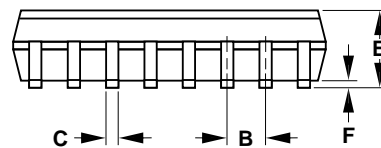
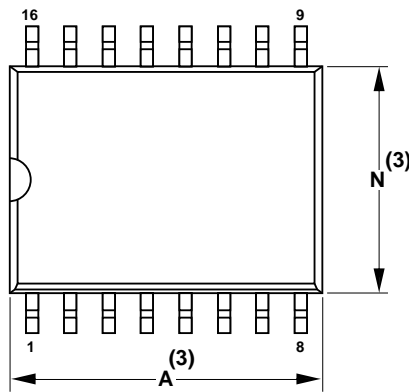

Notes:

- Package dimensions conform to JEDEC specification MS-013-AA for standard small outline (SO) package, 16 leads, 7.50 mm (.300 inch) body width (issue A, June 1985).
- Controlling dimensions are in mm.
- Dimensions are for the molded body and do not include mold flash or protrusions. Mold flash or protrusions shall not exceed .15 mm (.006 inch) on any side.
- Pin 1 side identified by chamfer on top edge of the package body or indent on Pin 1 end.

PI-1846-050196



NOTES



NOTES



NOTES

Power Integrations reserves the right to make changes to its products at any time to improve reliability or manufacturability. Power Integrations does not assume any liability arising from the use of any device or circuit described herein, nor does it convey any license under its patent rights or the rights of others.

PI Logo and **TOPSwitch** are registered trademarks of Power Integrations, Inc.
©Copyright 1994, Power Integrations, Inc. 477 N. Mathilda Avenue, Sunnyvale, CA 94086

WORLD HEADQUARTERS

Power Integrations, Inc.
477 N. Mathilda Avenue
Sunnyvale, CA 94086
USA
Main: 408•523•9200
Customer Service:
Phone: 408•523•9265
Fax: 408•523•9365

AMERICAS

For Your Nearest Sales/Rep Office
Please Contact Customer Service
Phone: 408•523•9265
Fax: 408•523•9365

EUROPE & AFRICA

Power Integrations (Europe) Ltd.
Mountbatten House
Fairacres
Windsor SL4 4LE
United Kingdom
Phone: 44•(0)•1753•622•208
Fax: 44•(0)•1753•622•209

JAPAN

Power Integrations, K.K.
Keihin-Tatemono 1st Bldg.
12-20 Shin-Yokohama 2-Chome, Kohoku-ku,
Yokohama-shi, Kanagawa 222
Japan
Phone: 81•(0)•45•471•1021
Fax: 81•(0)•45•471•3717

ASIA & OCEANIA

For Your Nearest Sales/Rep Office
Please Contact Customer Service
Phone: 408•523•9265
Fax: 408•523•9365

APPLICATIONS HOTLINE

World Wide 408•523•9260

APPLICATIONS FAX

Americas 408•523•9361
Europe/Africa
44•(0)•1753•622•209
Japan 81•(0)•45•471•3717
Asia/Oceania 408•523•9364

