

# SMP211

## PWM Power Supply IC

### 85-265 VAC Input

### Isolated, Regulated DC Output



### Product Highlights

#### Integrated Power Switch and CMOS Controller

- Output power up to 10 W from rectified 220 VAC input, 5 W from rectified universal (85 to 265 VAC) input
- External transformer provides isolated output voltages
- Integrated solution minimizes overall size

#### High-voltage, Low-capacitance MOSFET Output

- Designed for 120/220 V off-line applications
- Can also be used with DC inputs from 36 V to 400 V
- Low capacitance allows for high frequency operation

#### High-speed Voltage-mode PWM Controller

- Internal pre-regulator self-powers the IC on start-up
- Wide  $V_{BIAS}$  voltage range
- Designed for use with optocoupler feedback

#### Built-In Self-protection Circuits

- Adjustable cycle-by-cycle current limit
- Latching shutdown can be used for output overvoltage protection
- Input undervoltage lockout
- Thermal shutdown

## Description

The SMP211, intended for 220 V or universal off-line isolated power supply applications, combines a high voltage power MOSFET switch with a switchmode power system controller in a monolithic integrated circuit. Few external components are required to implement a small, low-cost, isolated, off-line power supply.

The high-speed power MOSFET switch features include high voltage, low  $R_{DS(ON)}$ , low capacitance, and low threshold voltage. Low capacitance and low threshold voltage reduce gate drive and bias power, allowing higher frequency operation.

The controller section of the SMP211 contains all the blocks required to drive and control the power stage: off-line pre-regulator, oscillator, bandgap reference, error amplifier, gate driver, and circuit protection. This voltage-mode Pulse Width Modulation control circuit is optimized for flyback topologies, but may be used with other topologies as well.

The SMP211 is available in a 16-pin plastic batwing DIP or 20-pin batwing SOIC package.

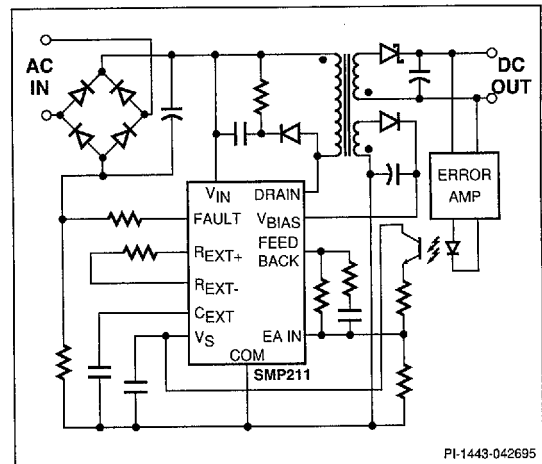

Figure 1. Typical Application

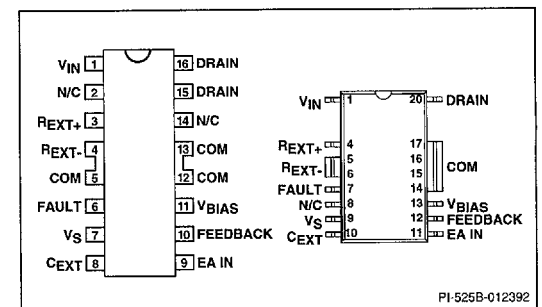

Figure 2. Pin Configuration

### ORDERING INFORMATION

PART NUMBER	PACKAGE OUTLINE	T <sub>J</sub> RANGE
SMP211BNI	P16B	-40 to 125°C
SMP211SRI	S20B	-40 to 125°C

www.DataSheet4U.com



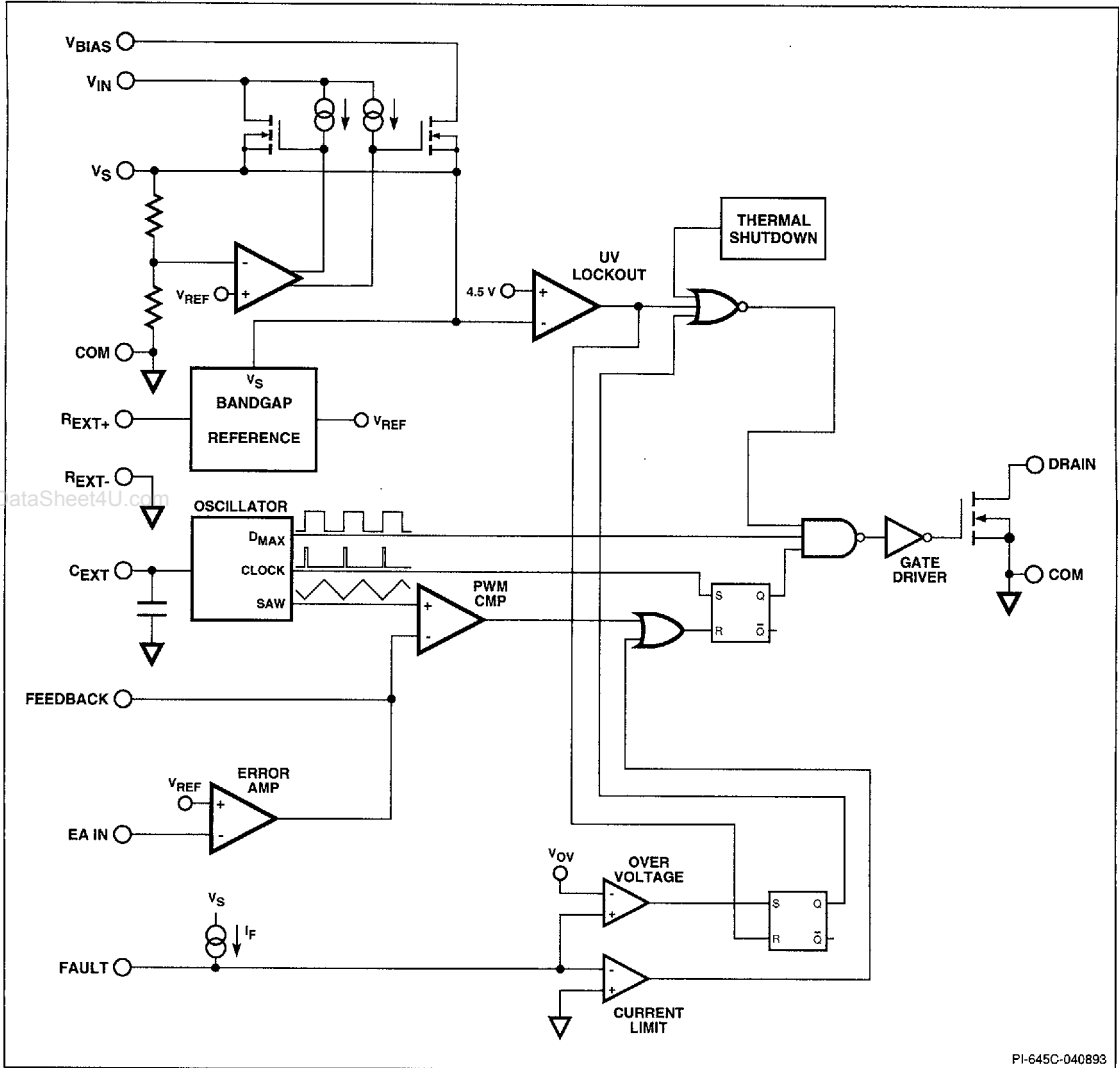

Figure 3. Functional Block Diagram of the SMP211.

PI-645C-040893



## Pin Functional Description

(Pin Number in Parentheses for SOIC version)

### Pin 1(1):

High voltage  $V_{IN}$  for connection to the high voltage pre-regulator used to self-power the device during start-up.

### Pin 2:

N/C for creepage distance.

### Pin 3(4):

A resistor placed between  $R_{EXT+}$  and  $R_{EXT-}$  sets the internal bias currents.

### Pin 4(5, 6):

$R_{EXT-}$  is the return for the reference current.

### Pin 5, 12, 13(14, 15, 16, 17):

COM connections. Ground or reference point for the circuit.

### Pin 6(7):

The **FAULT** pin is used with an external resistor to implement current limit. This pin may also driven by an optocoupler to implement over voltage protection of the power supply output.

### Pin 7(9):

Connection for a bypass capacitor for the internally generated  $V_S$  supply.

### Pin 8(10):

$C_{EXT}$  is used to set the oscillator frequency. Adding external capacitance lowers the PWM frequency.

### Pin 9(11):

**EA IN** is the error amplifier inverting input for connection to the external feedback and compensation networks.

### Pin 10(12):

**FEEDBACK** is the error amplifier output for connection to the external compensation network.

### Pin 11(13):

$V_{BIAS}$  is the bootstrap voltage used to self-power the device once the supply is operating.

### Pin 14:

N/C for creepage distance.

### Pin 15, 16(20):

Open **DRAIN** of the output MOSFET. Both pins must be externally connected.

## SMP211 Functional Description

### Bias Regulator

The onboard supply voltage ( $V_S$ ) is supplied from either of two high-voltage linear regulators. The  $V_{IN}$  linear regulator draws current from the high-voltage bus while the  $V_{BIAS}$  regulator draws current from a voltage generated from a transformer winding. The  $V_{IN}$  regulator dissipates significant power levels and should be cut off during normal operation for improved efficiency. The  $V_S$  error amplifier has a built-in preference for generating  $V_S$  from the  $V_{BIAS}$  regulator, which automatically cuts off the  $V_{IN}$  regulator during normal operation. During start-up and under power supply fault conditions, the bias error amplifier generates  $V_S$  from the  $V_{IN}$  regulator.

$V_S$  is the supply voltage for the controller and driver circuitry. An external bypass capacitor connected to  $V_S$  is required for filtering and noise immunity. The value of  $V_S$  also determines when the internal undervoltage lockout is enabled. Undervoltage lockout disables the power MOSFET until  $V_S$  is within its normal operating range.

### Bandgap Reference

$V_{REF}$  is a 1.25 V reference voltage generated by the temperature compensated bandgap reference. This reference voltage is used for setting thresholds for comparators, amplifiers, and the thermal shutdown circuit. The external resistor connected between  $R_{EXT+}$  and  $R_{EXT-}$  and the bandgap reference set the proper internal bias current levels for the various internal circuits.

### Oscillator

The oscillator linearly charges and discharges the combined internal and external capacitance between two different voltage levels to create a sawtooth waveform for the pulse width modulator. Two digital signals,  $D_{MAX}$  and **CLOCK** are also generated.  $D_{MAX}$  corresponds to the rising portion of the sawtooth waveform, and is used to gate the MOSFET driver. A short **CLOCK** pulse is used to reset the pulse width modulation and current limit latch at the beginning of each cycle.



## SMP211 Functional Description (cont.)

### Error Amplifier

The error amplifier consists of a high performance operational amplifier with the non-inverting input connected to the internal bandgap reference voltage. The output of the error amplifier directly controls the duty cycle of the power switch.

### Pulse Width Modulator

The pulse width modulator implements a voltage-mode control loop by driving the power MOSFET with a duty cycle proportional to the voltage on the FEEDBACK pin as shown in Figure 4. The duty cycle signal is generated by a comparator which compares the FEEDBACK voltage with the sawtooth waveform generated on the  $C_{EXT}$  pin. As the input voltage increases the duty cycle decreases. A clock signal from the oscillator sets a latch which turns on the power MOSFET. The pulse width modulator resets the latch, turning off the power MOSFET. The  $D_{MAX}$  signal from the oscillator limits the maximum duty cycle by gating the output driver.

### Fault Protection

The FAULT pin is used to implement both cycle-by-cycle MOSFET transistor current limiting and latching output shutdown protection.

The FAULT pin turns off the power MOSFET switch when an overcurrent condition causes the voltage on this pin to drop below the FAULT current limit threshold. The DRAIN current is converted to a voltage by an external sense resistor. An internal current source applied to an external offset resistor biases the FAULT signal to a positive voltage when no DRAIN current is flowing. During an overcurrent condition, current flowing in the sense resistor will cause the FAULT voltage to decrease. When the FAULT voltage falls below the fault current limit threshold for a time period exceeding the current limit delay, the power switch will be latched off until the beginning of the next clock cycle as shown in Figure 4. The FAULT pin will continuously limit the duty cycle on a cycle-by-cycle basis until the fault condition is removed.

For latching output overvoltage protection, an external optocoupler can be used to drive the FAULT pin above the FAULT OV threshold, as shown in Figure 5. A latch is set that turns off the power MOSFET switch. Cycling the undervoltage lockout circuit by removing and restoring input power is necessary to reset the latch and resume normal power supply operation.

### Overtemperature Protection

Temperature protection is provided by a precision analog circuit that turns the power switch off and reduces supply current when the switch junction gets too hot (typically 140°C). When the circuit has cooled past the hysteresis temperature, normal operation resumes.

## General Circuit Operation

The flyback power supply circuit shown in Figure 6 is a 5 volt, 5 watt power supply that operates from 85 to 265 V(rms) AC input voltage. The output voltage is directly sensed and accurately regulated by a secondary-referenced error amplifier. The error amplifier drives an error signal through an optocoupler to the SMP211 which directly controls the duty cycle of the integrated high voltage MOSFET switch. The effective output voltage can be fine-tuned by adjusting the resistive divider formed by R13 and R14. Other output voltages are possible by adjusting the transformer turns ratios as well as the resistor divider.

AC power is rectified and filtered by BR1 and C1 to create the high voltage DC bus applied to the primary winding of T1. The other side of the transformer primary is driven by the integrated high voltage MOSFET transistor within the SMP211. The clamp circuit implemented by R10, C9, and D5 clamps the leading edge voltage spike caused by transformer leakage inductance to a safe value. Ringing caused by parasitic capacitance and leakage inductance is damped by C15 and R9. The power secondary winding is rectified and filtered by D2, C2, and C10 to create the desired output voltage. The bias winding is rectified and filtered by D3 and C5 to create a bias voltage to the SMP211

which effectively cuts off the high voltage internal linear regulator. Common-mode emission currents which flow between the primary windings of the transformer and the secondary output circuitry are attenuated by C12, C17, C7, C8, L2, and L4. Differential-mode emission currents caused by pulsating currents at the input of the power supply are attenuated by C6 and L3. Voltage spikes on the AC line are clamped by VR1.

Internal bias currents are accurately set by R3. Bypass capacitor C3 filters current spikes on the internally generated voltage source  $V_S$ . The oscillator frequency is determined by C11.

[www.DataSheet4U.com](http://www.DataSheet4U.com)



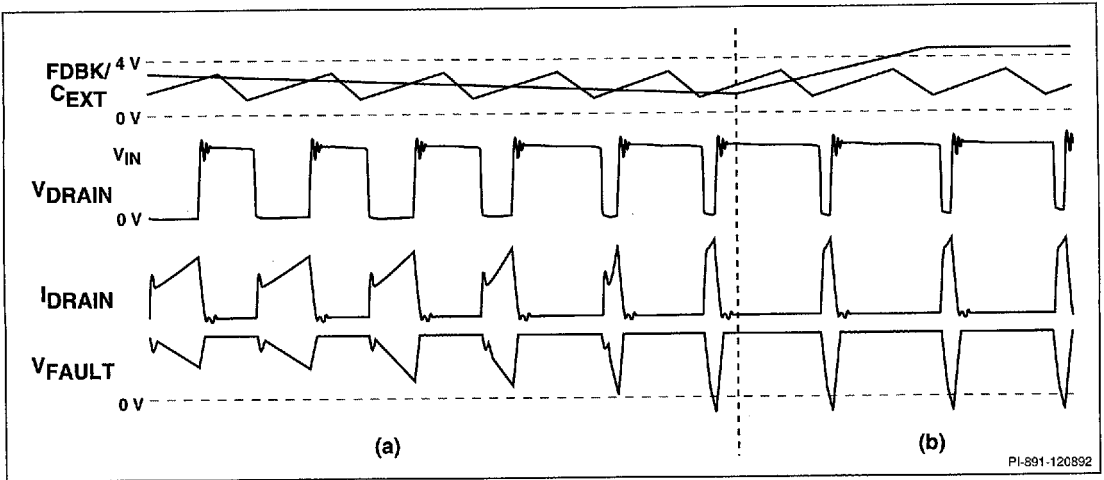

Figure 4. Typical Waveforms for (a) Normal Operation, and (b) Cycle-by-cycle Current Limit.

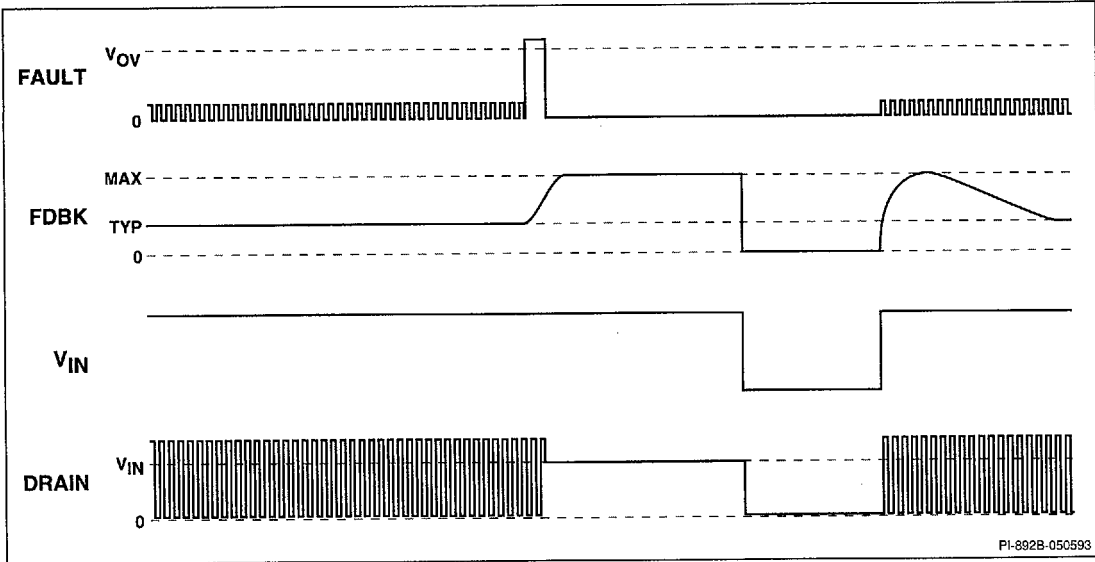

Figure 5. Typical Waveforms for Overvoltage Shutdown.



## 5 W Universal Off-line Power Supply with Optocoupler Feedback

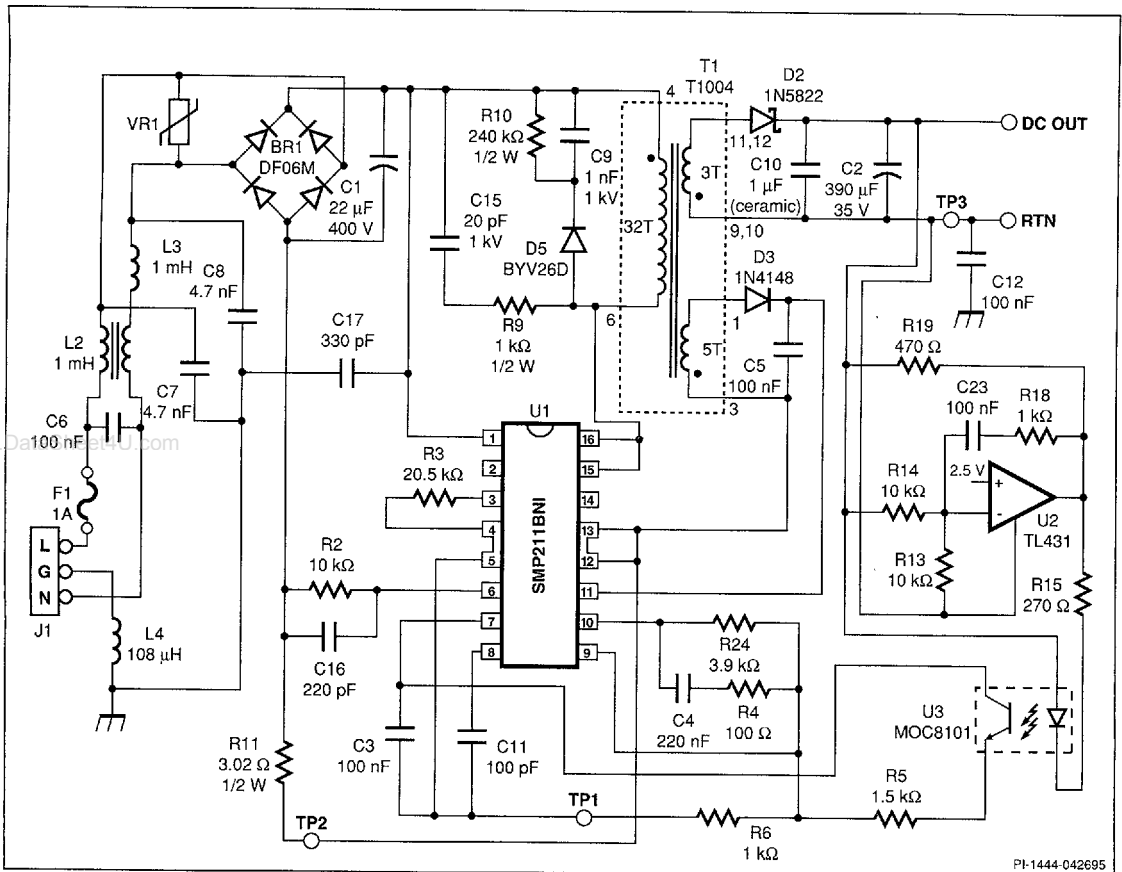

Figure 6. Schematic Diagram of a 5 V, 5 W Universal Input Power Supply Utilizing the SMP211 with Optocoupler Feedback.

## General Circuit Operation (cont.)

Transistor switch current is sensed by R11. The initial voltage level at the FAULT pin is determined by R2. C16 filters drain switching noise without delaying the current sense signal across R11.

The secondary-referenced error amplifier control system is implemented with a TL431 shunt regulator (U2). This device consists of an accurate 2.5 V bandgap reference, error amplifier, and driver. The output voltage is sensed,

divided by R13 and R14, and applied to the inverting input of the error amplifier. The non-inverting input of the error amplifier is internally connected to the bandgap reference voltage. The frequency response of the error amplifier is determined by the compensation network consisting of R18, C23, and the high frequency gain setting resistor R14. Bias current of 2 mA minimum for U2 is provided by R19. The LED current in the optocoupler is limited by R15.

To achieve full output power and reliable operation of the SMP211, both DRAIN outputs on the plastic batwing DIP version must be connected together at the printed circuit board. These pins are not connected within the package.

To reduce device power dissipation and temperature rise during normal operation, the voltage applied to  $V_{BIAS}$  must be greater than the minimum specified value to ensure complete cutoff of the high-voltage linear regulator. Ensure [www.DataSheet4U.com](http://www.DataSheet4U.com)

## General Circuit Operation (cont.)

voltage on the  $V_{BIAS}$  pin is not exceeded when adjusting the value of the output voltage.

Performance data is shown below for the power supply circuit given in Figure 6.

The line and load regulation graphs were measured when operated from a DC

source. The switching frequency of the power supply was measured at 250 kHz.

The maximum output power curve shows the power output capability for the normal transformer, and the performance with twice and half the normal number of primary turns.

The output power versus frequency curve

was generated by characterization of the SMP211 at various frequencies. Several different power transformers, optimized for each frequency, were used to generate the maximum power at each point. The curves illustrate the trade-off between AC and DC power losses within the device. As AC losses rise with frequency, DC losses and output power must be reduced to maintain the same device maximum power dissipation.

## Typical Performance Characteristics (Figure 6 Power Supply)

LINE REGULATION

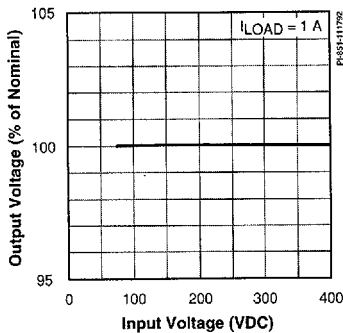

LOAD REGULATION

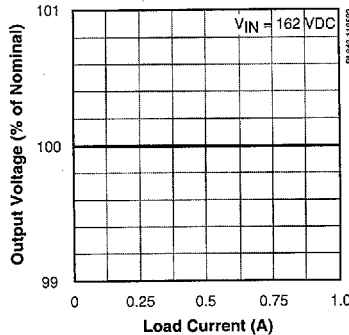

MAXIMUM OUTPUT POWER

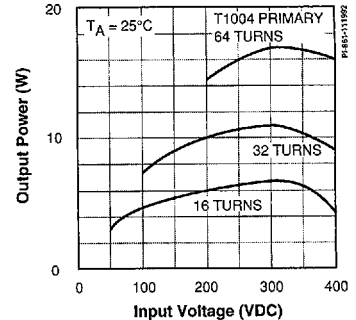

EFFICIENCY vs. INPUT VOLTAGE

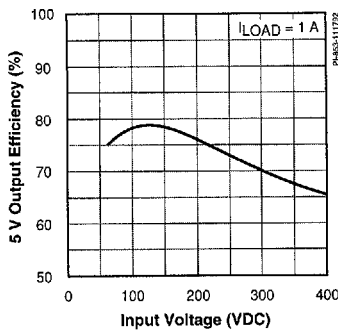

EFFICIENCY vs. OUTPUT POWER

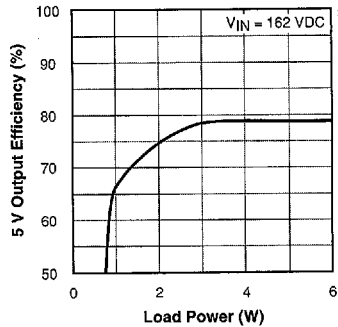

OUTPUT POWER vs. FREQUENCY

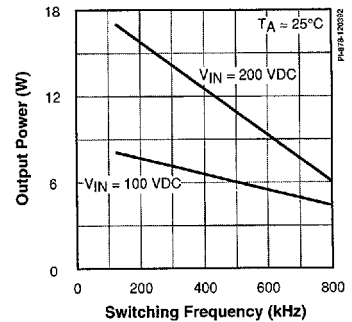

2



## Upgrading Existing SMP210 Designs to the SMP211

The SMP211 is compatible with PC boards designed for the SMP210. The resistor required between  $V_s$  and  $I_{LIMIT}$  on the SMP210 has been eliminated on the SMP211. The  $I_{LIMIT}$  pin on the SMP210 has been renamed to FAULT on the SMP211 due to the additional

over voltage protection feature. External resistor R2 will have a different value when using the SMP211.

EA- and EAO on the SMP210 have been renamed EA IN and FEEDBACK on the SMP211 because of the use of the internal

error amplifier is optional. When using primary-referenced feedback winding control the functionality is the same for both devices. An example of this method using the SMP211 is shown in Figure 7.

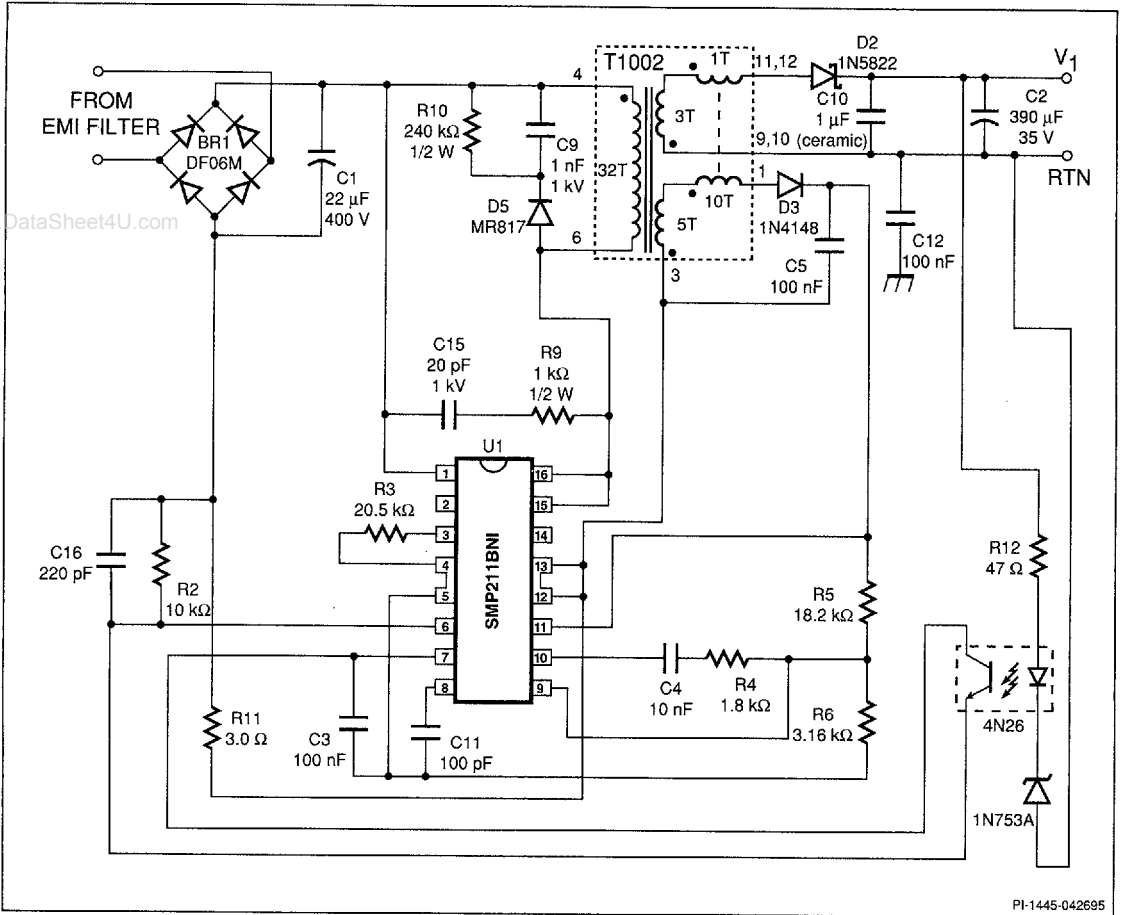

Figure 7. Implementing Feedback Winding Regulation and Output Overvoltage Protection.

## Implementing Output Overvoltage Protection

If the load is extremely sensitive to overvoltage conditions, an overvoltage shutdown function can be implemented as shown in Figure 7. The output voltage is fed back to the SMP211 via an op amp

and optocoupler. If the voltage at pin 6 is greater than  $V_{OV}$ , the internal latch will shut off the output.

The SMP211 must be restarted by removing the input voltage and then reapplying it, causing the latch to reset and the circuit to begin a new startup cycle. [www.DataSheet4U.com](http://www.DataSheet4U.com)





**ABSOLUTE MAXIMUM RATINGS<sup>1</sup>**

Drain Voltage .....	800 V	Thermal Impedance ( $\theta_{JA}$ ) (BN Suffix) .....	43°C/W
$V_{IN}$ Voltage .....	500 V	(SR Suffix) .....	30°C/W
$V_{BIAS}$ Voltage .....	35 V	Thermal Impedance ( $\theta_{IC}$ ) <sup>(6)</sup> (BN Suffix) .....	6°C/W
Drain Current <sup>(2)</sup> .....	800 mA	(SR Suffix) .....	6°C/W
Input Voltage <sup>(3)</sup> .....	-0.3 V to $V_S + 0.3$ V		
Storage Temperature .....	-65 to 125°C		
Operating Junction Temperature <sup>(4)</sup> .....	-40 to 150°C		
Lead Temperature <sup>(5)</sup> .....	260°C		
Power Dissipation			
BN Suffix ( $T_A = 25^\circ\text{C}$ ) .....	2.33 W		
( $T_A = 70^\circ\text{C}$ ) .....	1.28 W		
SR Suffix ( $T_A = 25^\circ\text{C}$ ) .....	3.33 W		
( $T_A = 70^\circ\text{C}$ ) .....	1.83 W		

1. Unless noted, all voltages referenced to COM,  $T_A = 25^\circ\text{C}$
2. 300  $\mu\text{s}$ , 2% duty cycle.
3. Does not apply to  $V_{IN}$  or DRAIN.
4. Normally limited by internal circuitry.
5. 1/16" from case for 5 seconds.
6. Measured at pin 12/13 (BN Suffix), or pin 15/16 (SR Suffix).

Parameter	Symbol	Conditions				Units		
		(Unless Otherwise Specified) $V_{IN} = 325$ V, $V_{BIAS} = 8.5$ V, COM = 0 V $R_{EXT} = 20.5$ k $\Omega$ , $C_{EXT} = 100$ pF $T_A = -40$ to 125°C (See Note 1)						
		Min	Typ	Max				
<b>OSCILLATOR</b>								
Output Frequency	$f_{OSC}$	$C_{EXT} = \text{Open}$			900	kHz		
		193	233	272				
<b>PULSE WIDTH MODULATOR</b>								
Duty Cycle Range	DC	$C_{EXT} = \text{Open}$			0-35	0-40	%	
		0-48	0-52					
<b>CIRCUIT PROTECTION</b>								
FAULT Offset Current	$I_F$	-103	-93	-83		$\mu\text{A}$		
FAULT OV Threshold	$V_{OV}$	3.5	$V_S - 1.6$ V	4.9		V		
FAULT Current Limit Threshold	$V_{ILIMIT}$	-100		0		mV		
Current Limit Delay Time	$t_{d(off)}$	See Figure 8			75	150	250	ns
Thermal Shutdown Temperature		125	140				$^\circ\text{C}$	
Thermal Shutdown Hysteresis			15				$^\circ\text{C}$	



Parameter	Symbol	Conditions			Min	Typ	Max	Units
		(Unless Otherwise Specified) $V_{IN} = 325 \text{ V}$ , $V_{BIAS} = 8.5 \text{ V}$ , $COM = 0 \text{ V}$ $R_{EXT} = 20.5 \text{ k}\Omega$ , $C_{EXT} = 100 \text{ pF}$ $T_j = -40 \text{ to } 125^\circ\text{C}$ (See Note 1)						
<b>ERROR AMPLIFIER</b>								
Reference Voltage	$V_{REF}$			1.21	1.25	1.29		V
Reference Voltage Temperature Drift	$\Delta V_{REF}$				$\pm 300$			ppm/ $^\circ\text{C}$
Gain-Bandwidth Product					500			kHz
DC Gain	$A_{VOL}$			60	80			dB
Output Current	$I_{OUT}$	$V_{FB} = 2.3 \text{ V}$			-2.5			mA
		$V_{FB} = 1.1 \text{ V}$			0.7			
Output Impedance	$Z_{OUT}$				27			$\Omega$
<b>OUTPUT</b>								
ON-State Resistance	$R_{DS(ON)}$	$I_D = 100 \text{ mA}$	$T_j = 25^\circ\text{C}$		20	25		$\Omega$
			$T_j = 100^\circ\text{C}$		33	43		
ON-State Current	$I_{D(ON)}$	$V_{DS} = 10 \text{ V}$	$T_j = 25^\circ\text{C}$	300	380			mA
			$T_j = 100^\circ\text{C}$	200	240			
OFF-State Current	$I_{DSS}$	$V_{DRAIN} = 640 \text{ V}$ , $T_A = 125^\circ\text{C}$				100	500	$\mu\text{A}$
Breakdown Voltage	$BV_{DSS}$	$I_{DRAIN} = 250 \mu\text{A}$ , $T_A = 25^\circ\text{C}$			800			V
Output Capacitance	$C_{OSS}$	$V_{DRAIN} = 25 \text{ V}$ , $f = 1 \text{ MHz}$				45		pF
Output Stored Energy	$E_{OSS}$	$V_{DRAIN} = 400 \text{ V}$				700		nJ
Rise Time	$t_r$	See Figure 8				70	150	ns
Fall Time	$t_f$	See Figure 8				70	150	ns

Parameter	Symbol	Conditions			Min	Typ	Max	Units
		(Unless Otherwise Specified) $V_{IN} = 325\text{ V}$ , $V_{BIAS} = 8.5\text{ V}$ , $COM = 0\text{ V}$ $R_{EXT} = 20.5\text{ k}\Omega$ , $C_{EXT} = 100\text{ pF}$ $T_j = -40\text{ to }125^\circ\text{C}$ (See Note 1)						
<b>SUPPLY</b>								
Pre-regulator Voltage	$V_{IN}$			36		500		V
Off-line Supply Current	$I_{IN}$	$V_{BIAS}$ not connected, $C_{EXT} = \text{Open}$			3	4.5		mA
		$V_{BIAS} > 8.25\text{ V}$				0.1		
		Thermal Shutdown ON					2	
$V_{BIAS}$ Supply Voltage	$V_{BIAS}$	$V_{BIAS}$ externally supplied		8.25		30		V
$V_{BIAS}$ Supply Current	$I_{BIAS}$	$V_{BIAS}$ externally supplied			3	4.5		mA
$V_S$ Source Voltage	$V_S$			5.1		6.4		V
$V_S$ Source Current	$I_S$					5		mA

**NOTES:**

- Applying  $>3.5\text{ V}$  to the  $C_{EXT}$  pin activates an internal test circuit that turns on the output switch continuously. Destruction of the part can occur if the output of the SMP211 is connected to a high voltage power source when the test circuit is activated.

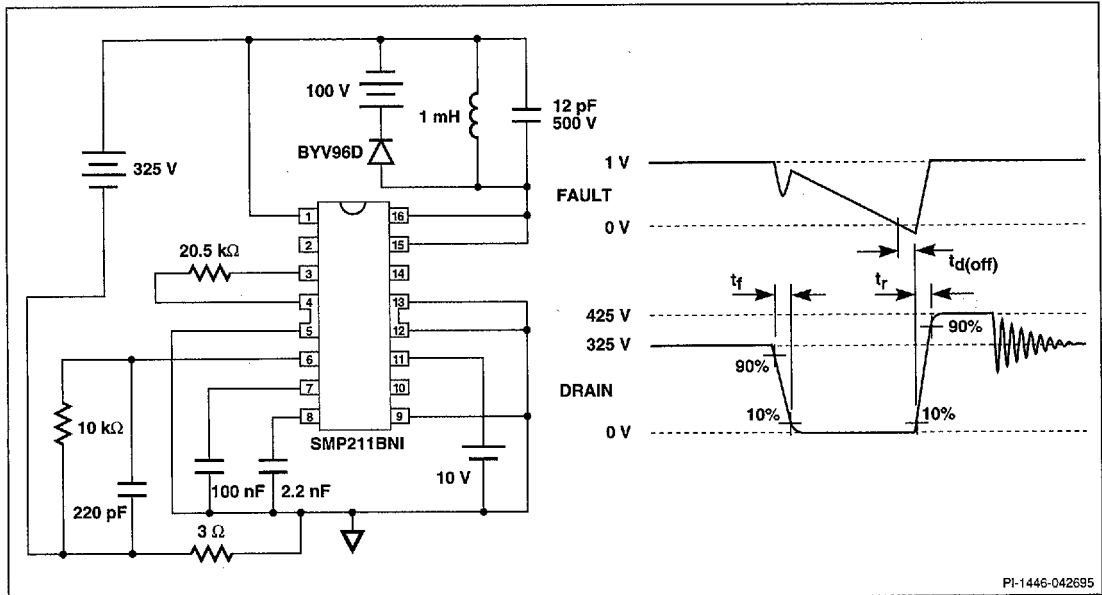
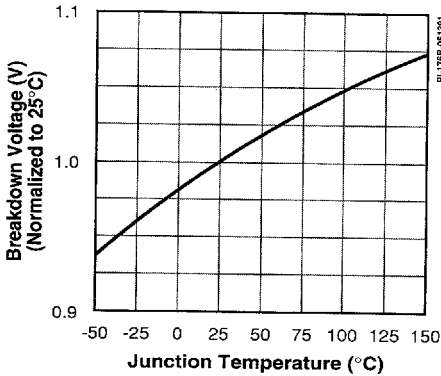

Figure 8. Current Limit Delay/Switching Time Test Circuit.



**BREAKDOWN vs. TEMPERATURE**



**f<sub>PWM</sub> vs. EXTERNAL CAPACITANCE**

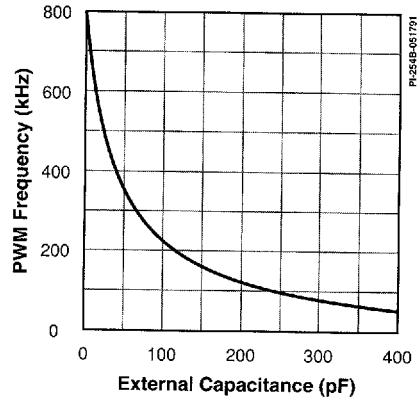

www.DataSheet4U.com

**C<sub>oss</sub> vs. DRAIN VOLTAGE**

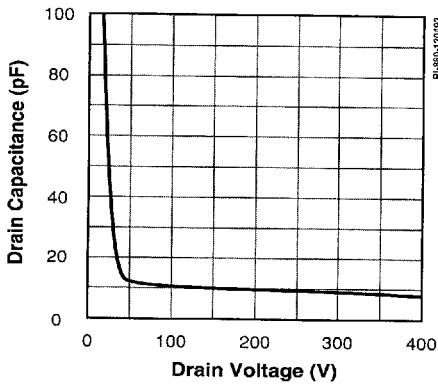

**DRAIN CHARGE vs. DRAIN VOLTAGE**

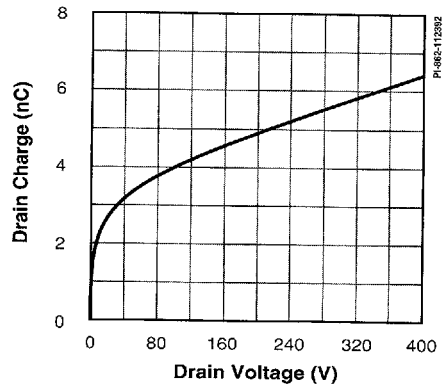

2

**DRAIN CAPACITANCE ENERGY**

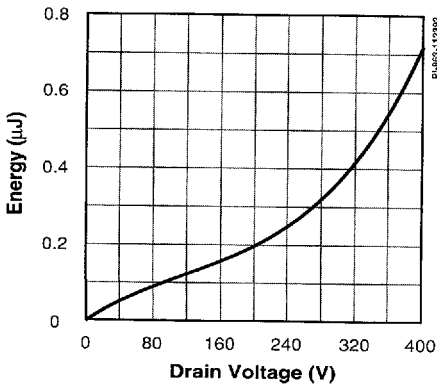

**OUTPUT CHARACTERISTICS**

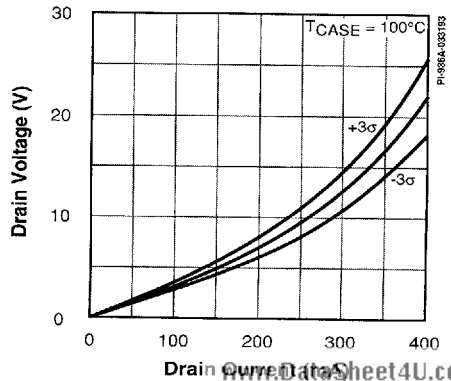

www.DataSheet4U.com



PACKAGE POWER DERATING

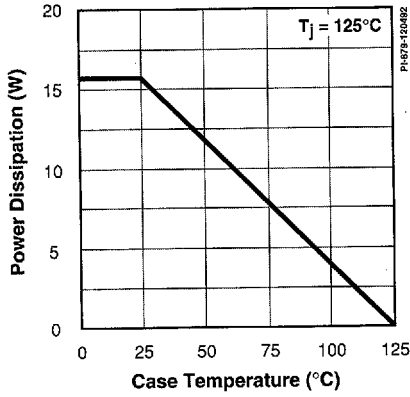

TRANSIENT THERMAL IMPEDANCE

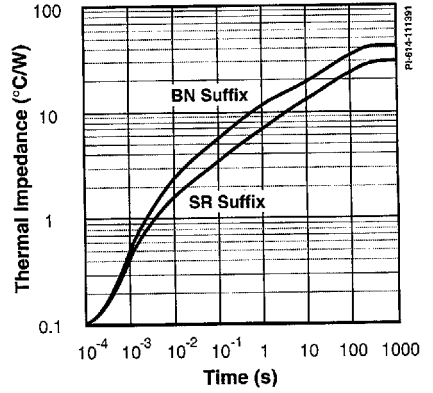

Y03A

Plastic TO-220/3

DIM	inches	mm
A	.460-.480	11.68-12.19
B	.400-.415	10.16-10.54
C	.236-.260	5.99-6.60
D	.240 - REF.	6.10 - REF.
E	.520-.560	13.21-14.22
F	.028-.038	.71-.97
G	.045-.055	1.14-1.40
H	.090-.110	2.29-2.79
J	.165-.185	4.19-4.70
K	.045-.055	1.14-1.40
L	.095-.115	2.41-2.92
M	.015-.020	.38-.51
N	.705-.715	17.91-18.16
O	.146-.156	3.71-3.96
P	.103-.113	2.62-2.87

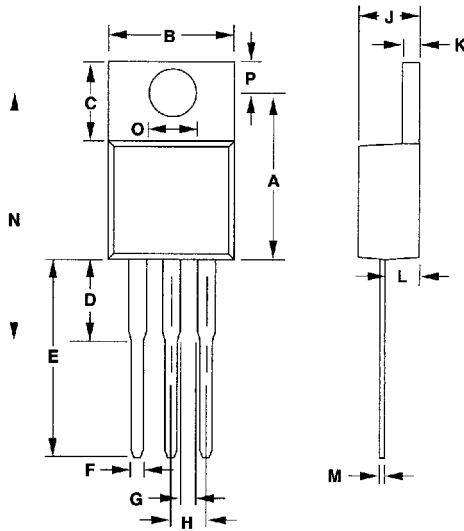

- Notes:
1. Package dimensions conform to JEDEC specification TO-220 AB for standard flange mounted, peripheral lead package; .100 inch lead spacing (Plastic) 3 leads (Issue J, March 1987)
  2. Controlling dimensions are inches.
  3. Pin numbers start with Pin 1, and continue from left to right when viewed from the top.
  4. Dimensions shown do not include mold flash or other protrusions. Mold flash or protrusions shall not exceed .006 (.15 mm) on any side.
  5. Position of terminals to be measured at a position .25 (6.35 mm) from the body.
  6. All terminals are solder plated.

PI-1848-050696

P08A

Plastic DIP-8

Dim.	inches	mm
A	.395 MAX	10.03 MAX
B	.090-.110	2.29-2.79
C	.015-.021	0.38-0.53
D	.040 TYP	1.02 TYP
E	.015-.030	0.38-0.76
F	.125 MIN	3.18 MIN
G	.015 MIN	0.38 MIN
H	.125-.135	3.18-3.43
J	.300-.320	7.62-8.13
K	.245-.255	6.22-6.48
L	.009-.015	0.23-0.38

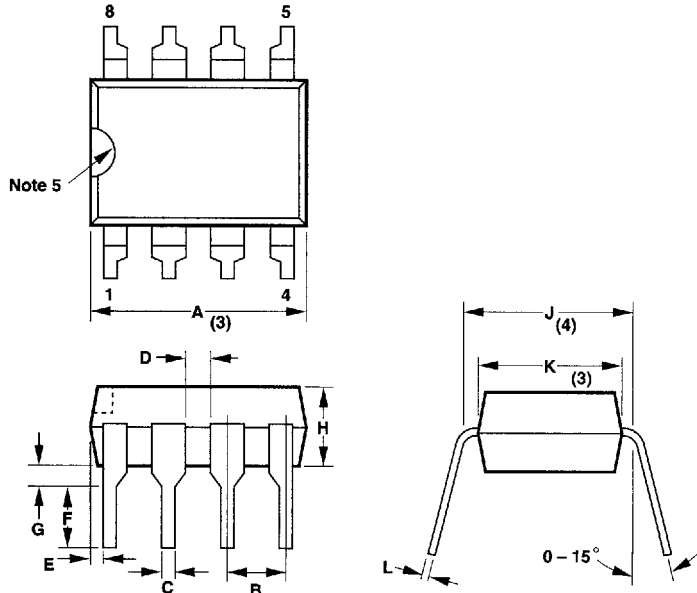

- Notes:
1. Package dimensions conform to JEDEC specification MS-001-AB for standard dual in-line (DIP) package .300 inch row spacing (PLASTIC) 8 leads (Issue B, 7/85).
  2. Controlling dimensions: inches.
  3. Dimensions are for the molded body and do not include mold flash or other protrusions. Mold flash or protrusions shall not exceed .010 inch (.25 mm) on any side.
  4. These dimensions measured with the leads constrained to be perpendicular to package bottom.
  5. Pin 1 orientation identified by end notch or dot adjacent to Pin 1.

PI-1842-050196

P16B

Plastic DIP-16

DIM	Inches	mm
A	.780 MAX	19.81 MAX
B	.090-.110	2.29-2.79
C	.015-.021	.38-.53
D	.040 TYP	1.02 TYP
E	.015-.030	.38-.76
F	.125 MIN	3.18 MIN
G	.015 MIN	.38 MIN
H	.125-.135	3.18-3.43
J	.300-.320	7.62-8.13
K	.245-.255	6.22-6.48
L	.009-.015	.23-.38

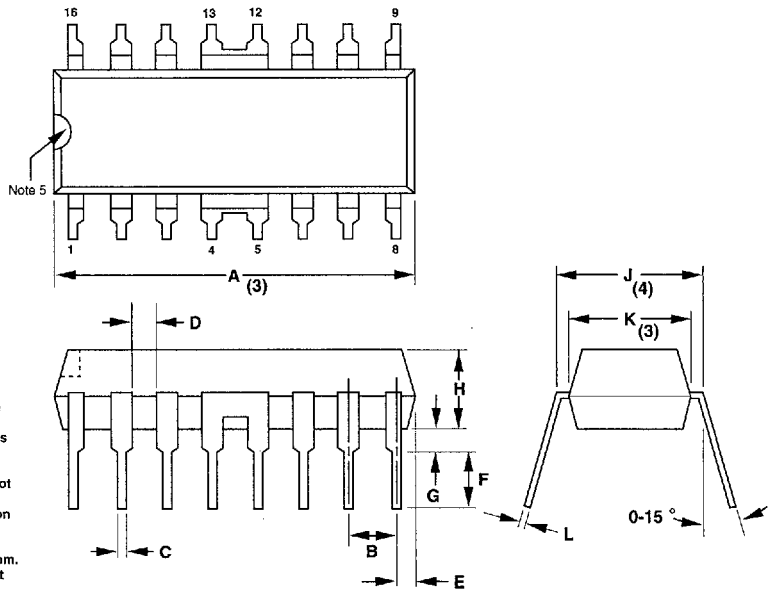

- Notes:
1. Package dimensions conform to JEDEC specification MS-001-AA for standard dual in-line (DIP) package .300 inch row spacing (PLASTIC) 16 leads (Issue B, 7/85). Except for joining of Pins 4-5 and Pins 12-13.
  2. Controlling dimension: inches.
  3. Dimensions are for the molded body and do not include mold flash or protrusions. Mold flash or protrusions shall not exceed .010 inch (.25 mm) on any side.
  4. These dimensions measured with the leads constrained to be perpendicular to package bottom.
  5. Pin 1 orientation identified by end notch or dot adjacent to Pin 1.

PI-1844-050196

T08A

Plastic SO-8

DIM	Inches	mm
A	0.189-0.197	4.80-5.00
B	0.050 TYP	1.27 TYP
C	0.014-0.019	0.35-0.49
D	0.012 TYP	0.31 TYP
E	0.053-0.069	1.35-1.75
F	0.004-0.010	0.10-0.25
G	0.228-0.244	5.80-6.20
H	0.007-0.010	0.19-0.25
J	0.021-0.045	0.51-1.14
K	0.150-0.157	3.80-4.00

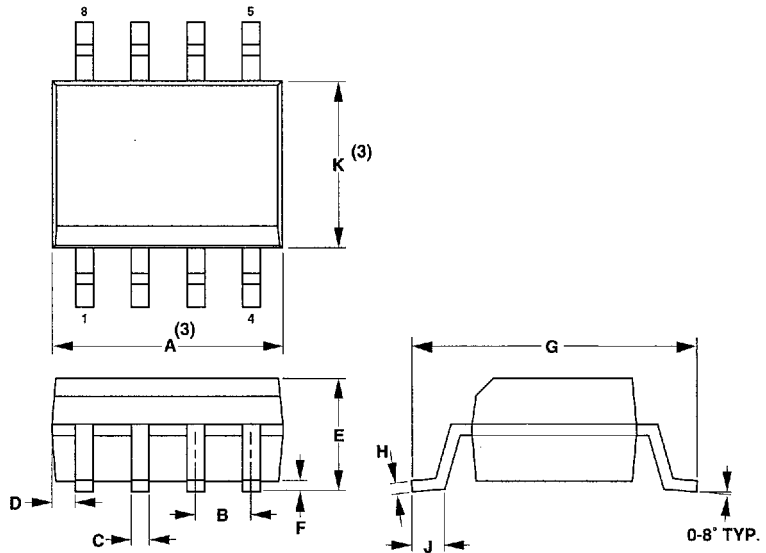

- Notes:
1. Package dimensions conform to JEDEC specification MS-012-AA for standard small outline (SO) package, 8 leads, 3.75 mm (.150 inch) body width (Issue A, June 1985).
  2. Controlling dimensions are in mm.
  3. Dimensions are for the molded body and do not include mold flash or protrusions. Mold flash or protrusions shall not exceed .15 mm (.006 inch) on any side.
  4. Pin 1 side identified edge by chamfer on top of the package body or indent on Pin 1 end.

PI-1845-050196



S16A

Plastic SO-16 (W)

DIM	inches	mm
A	.398-.413	10.10-10.50
B	.050 BSC	1.27 BSC
C	.014-.018	0.36-0.46
E	.093-.104	2.35-2.65
F	.004-.012	0.10-0.30
J	.394-.418	10.01-10.62
L	.009-.012	0.23-0.32
M	.020-.040	0.51-1.02
N	.291-.299	7.40-7.60

Notes:

1. Package dimensions conform to JEDEC specification MS-013-AA for standard small outline (SO) package, 16 leads, 7.50 mm (.300 inch) body width (issue A, June 1985).
2. Controlling dimensions are in mm.
3. Dimensions are for the molded body and do not include mold flash or protrusions. Mold flash or protrusions shall not exceed .15 mm (.006 inch) on any side.
4. Pin 1 side identified by chamfer on top edge of the package body or indent on Pin 1 end.

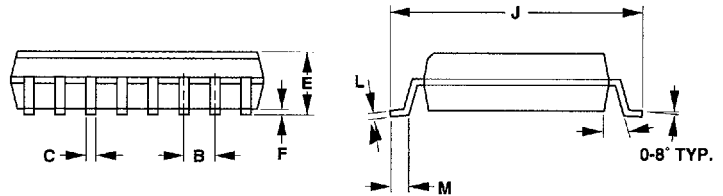
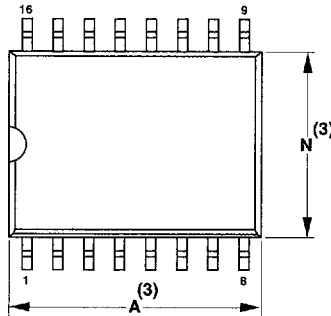

PI-1846-050196

S20B

Plastic SO-20

DIM	inches	mm
A	.496-.512	12.60-13.00
B	.050 BSC	1.27 BSC
C	.014-.019	0.35-0.49
E	.093-.104	2.35-2.65
F	.004-.012	0.10-0.30
J	.394-.419	10.00-10.65
L	.009-.013	0.23-0.32
M	.016-.050	0.40-1.27
N	.291-.299	7.40-7.60

Notes:

1. Package dimensions conform to JEDEC specification MS-013-AC for standard small outline (SO) package, 20 leads, 7.50 mm (.300 inch) body width (issue A, June 1985). Except for joining of Pins 5-6 and Pins 13-14-15.
2. Controlling dimensions are in mm.
3. Dimensions are for the molded body and do not include mold flash or protrusions. Mold flash or protrusions shall not exceed .15 mm (.006 inch) on any side.
4. Pin 1 side identified by chamfer on top edge of the package body or indent on Pin 1 end.

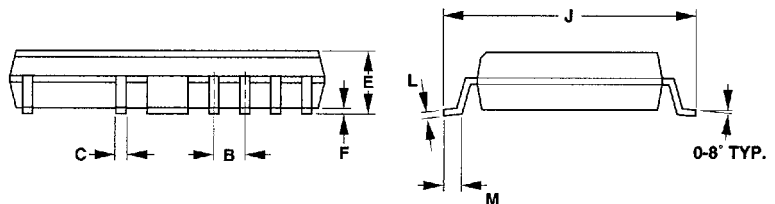
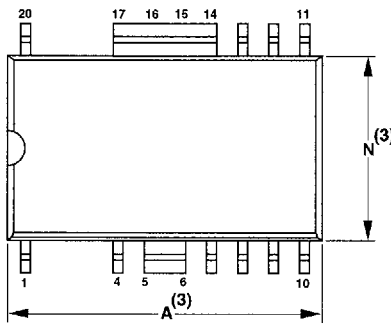

PI-1847-050198



# Tape & Reel Ordering Information



Power Integrations, Inc. makes selected surface-mount parts available in tape and reel form for use with automatic pick-and-place equipment. Tape and reel specifications meet or exceed industry standard specification EIA-481.

## Ordering Information

Parts available in tape and reel form can be ordered by placing a T&R ordering suffix after the base part number. Standard orientation is Pin 1 Left. The ordering suffix for this orientation (see Figure 1) is TL. For example:

Base Part #      T&R Suffix  
INT100S          -TL

Please contact the factory for other options. Minimum order size is 1 reel per line item, and all orders will be in multiples of full reel quantities. The quantity per reel for each package type is shown in Table 1. Power Integrations normal terms and conditions apply.

## Electrical Specifications

Parts are subjected to the Power Integrations standard test flow, after which the parts are loaded into the tape cavities and sealed with a cover tape using standard anti-static handling procedures. The tape and cover are constructed of conductive modified polystyrene, providing a surface resistivity of  $\leq 10^6 \Omega/\text{square}$ . The reel is made of polystyrene with a topical anti-static coating, providing a surface resistivity of  $\leq 10^{11} \Omega/\text{square}$ .

## Physical Specifications

Physical specifications of the tape, cover, and reel are governed by EIA-481. Physical dimensions of the tapes are given in Figure 2 and Table 2, and physical dimensions of the reels are given in Figure 3 and Table 3.

## 5 Packaging for Shipment

Power Integrations supplies the following information on the side of each reel for ease of product identification:

- Power Integrations part number (MPN), including orientation suffix
- Encapsulation date code (D/C)
- Assembly lot identification (LOT)
- Quantity (QTY)
- Tape and reel packing date code (R/D)

PACKAGE	TAPE		REEL DIA	REEL QTY
	WIDTH (W)	PITCH (P)		
SO-8	12mm	8mm	330mm	2500
SO-16 (W)	16mm	12mm	360mm	1000
SO-20	24mm	12mm	360mm	1000

Table 1. Primary Tape & Reel Dimensions and Reel Quantities.

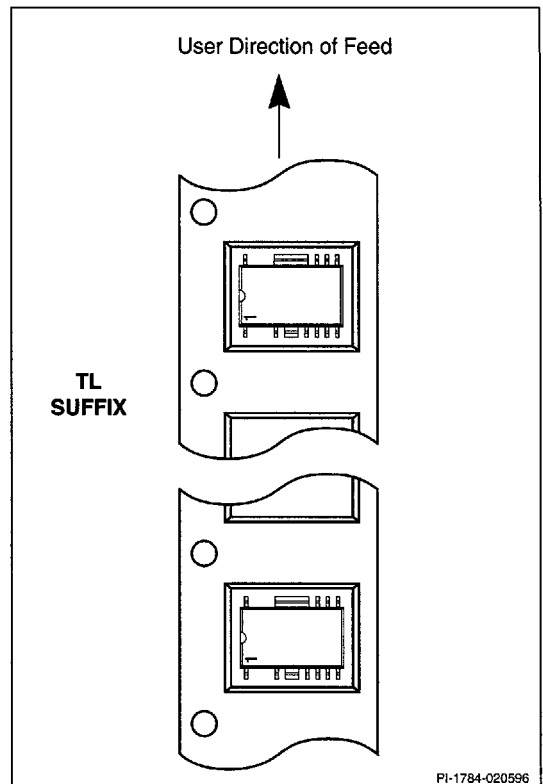
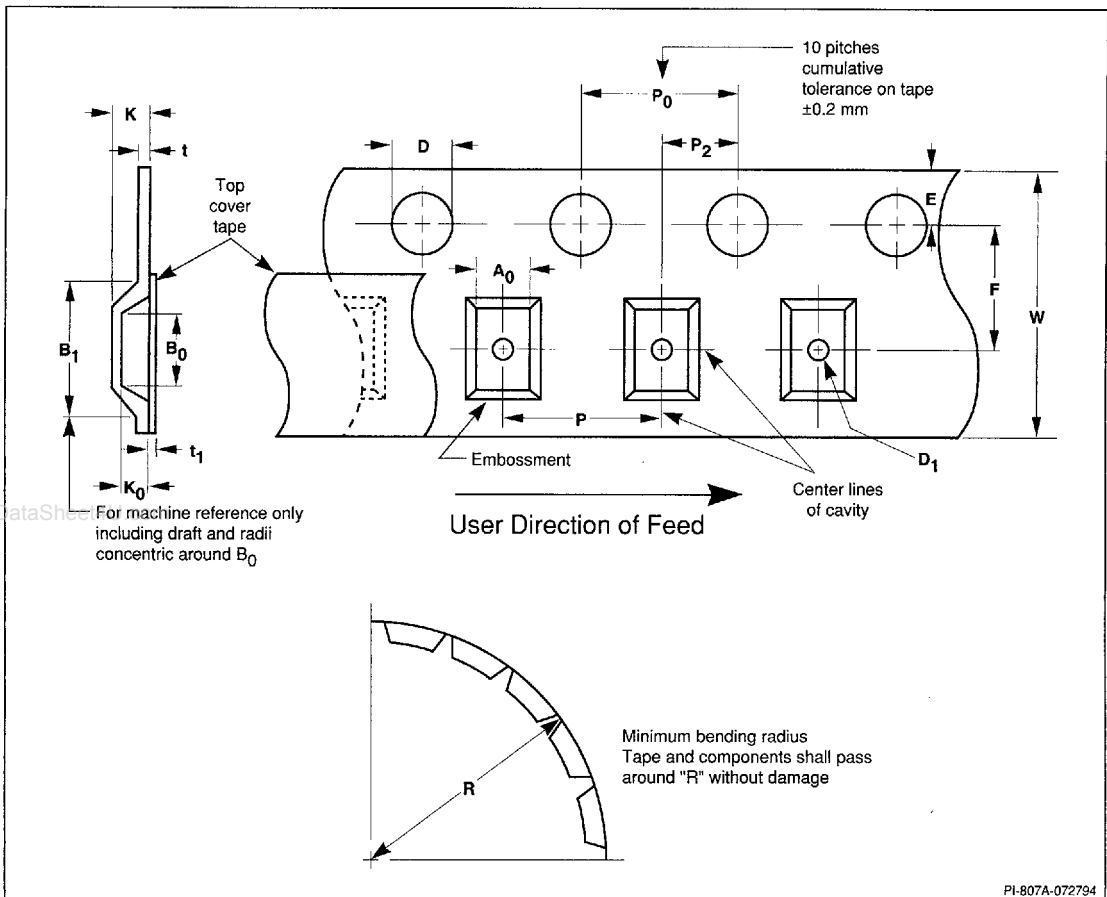

Figure 1. Part Orientation and Ordering Suffix.





PI-807A-072794

Figure 2. Tape Dimension Index.

Package Type	Tape Size	$A_0$	$B_0$	$B_1$	D	$D_1$	E	F	K
Plastic SO-8	12 mm	6.3-6.5	5.1-5.3	8.2 (max)	1.5-1.6	1.5 (min)	1.65-1.85	5.45-5.55	4.5 (max)
Plastic SO-16 (W)	16 mm	10.8-11.0	10.6-10.8	12.1 (max)	1.5-1.6	1.5 (min)	1.65-1.85	7.40-7.60	6.5 (max)
Plastic SO-20	24 mm	10.8-11.0	13.2-13.4	20.1 (max)	1.5-1.6	1.5 (min)	1.65-1.85	11.40-11.60	6.5 (max)

Package Type	Tape Size	$K_0$	P	$P_0$	$P_2$	R	t	$t_1$	W
Plastic SO-8	12 mm	2.00-2.20	7.9-8.1	3.9-4.1	1.95-2.05	30 (min)	0.400 (max)	0.10 (max)	11.7-12.3
Plastic SO-16 (W)	16 mm	2.90-3.10	11.9-12.1	3.9-4.1	1.90-2.10	40 (min)	0.400 (max)	0.10 (max)	15.7-16.3
Plastic SO-20	24 mm	2.90-3.10	11.9-12.1	3.9-4.1	1.90-2.10	50 (min)	0.400 (max)	0.10 (max)	23.7-24.3

Table 2. Tape Dimensions (in mm).



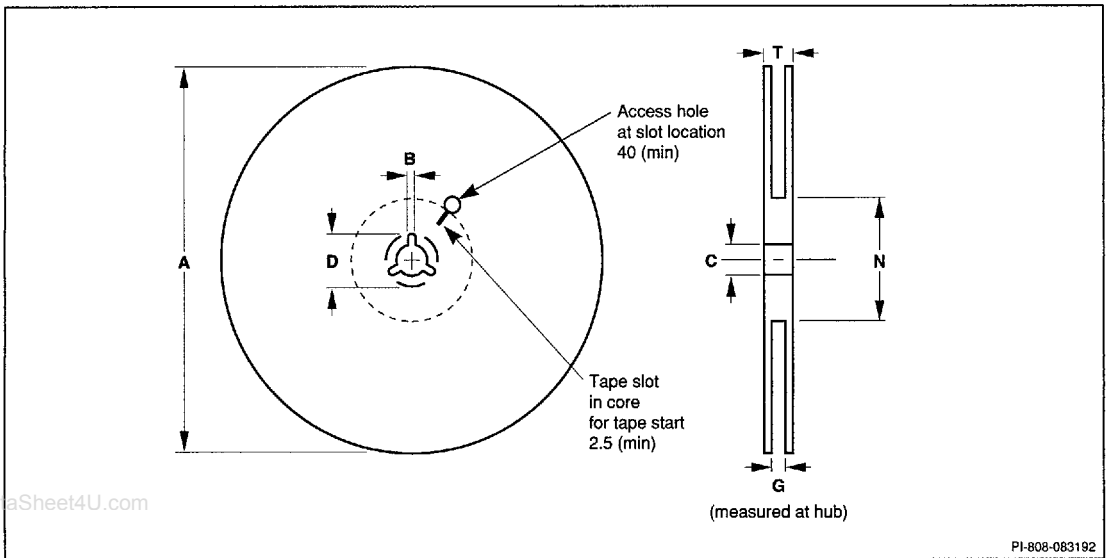

Figure 3. Reel Dimension Index.

Package Type	Tape Size	A	B	C	D	G	N	T
Plastic SO-8	12 mm	330 (max)	1.5 (min)	12.80-13.20	20.2 (min)	12.4-14.4	50 (min)	18.4 (max)
Plastic SO-16 (W)	16 mm	360 (max)	1.5 (min)	12.80-13.20	20.2 (min)	16.4-18.4	50 (min)	22.4 (max)
Plastic SO-20	24 mm	360 (max)	1.5 (min)	12.80-13.20	20.2 (min)	24.4-26.4	50 (min)	30.4 (max)

Table 3. Reel Dimensions (in mm).

