

IEEE 1394b S200 Transceiver Pair

FDL300E/FDL300D

650 nm 250 Mbps Fiber Optic Transceiver Solution for Seamless Digital to Light/ Light to Digital Conversion

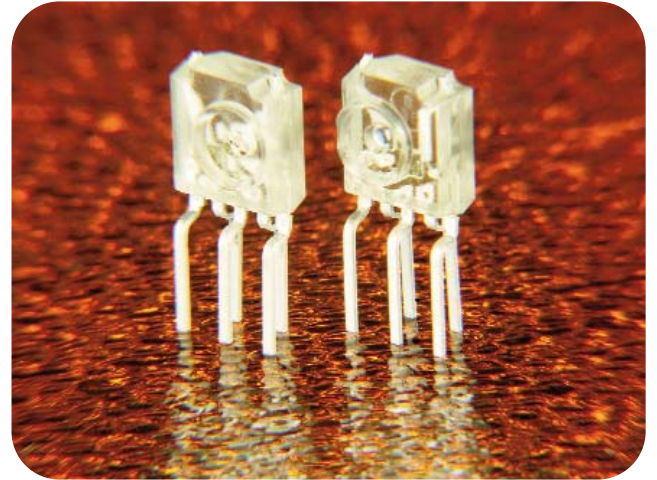

FEATURES

- Meets the IEEE 1394b S200 (250 Mbps) specification
- Integrated CMOS driver IC
- Resonant Cavity LED at red 650 nm with small emission aperture suitable for Plastic Optical Fiber (POF)
- Resonant Cavity LED reliability tested to over 400,000 hours lifetime
- Configured for IEEE 1394b with LVDS I/O
- High sensitivity receiver IC and pin-diode for one-step light to digital conversion
- Compatible with SMI connector form factor
- Integrated optics to efficiently focus and direct light
- Ultra-low power consumption



DESCRIPTION

Firecomms RCLED-based 650 nm fiber optic transceiver (FOT) solution provides a seamless digital media to red light conversion, and subsequent recovery for performance at maximum speed in POF applications such as IEEE 1394b S200. The FOTs operate at LVDS signal levels directly compatible with IEEE 1394b PHY ICs.

The FOT solution pairs Firecomms RCLED (Resonant Cavity Light Emitting Diode) technology with an encapsulated driver IC for coupling digital media signals to light in a POF link. At the receive side, the solution provides a 250 Mbps capacity light receiver in an integrated package that recovers digital media compatible signals (IEEE 1394 LVDS). The integration of the emitter Tx FOT with its driver IC and a pin-diode Rx FOT with a receiver IC in a POF link provides for a high-integrity digital data link over a range of up to 50m at 250 Mbps (S200), depending on installation conditions.

APPLICATIONS

Application	Standard	Distance	Speed
Home/Office Network	IEEE 1394b S100	100 meters	125 Mbps
Home/Office Network, High Speed	IEEE 1394b S200	50 meters	250 Mbps

ABSOLUTE MAXIMUM RATINGS^[1]

Parameter	Symbol	Minimum	Maximum	Unit
Storage Temperature	T _{stg}	-40	+100	°C
Operating Temperature	T _{op}	-20	+70	°C
Soldering Temperature ^[2]			+260	°C
Supply Voltage	V _{cc}	-0.5	+4.5	V

Notes:

1. These are absolute maximum ratings at or beyond which the FOT can be expected to be damaged.
2. 260°C, 5s 3 times, at least 2.2 mm away from lead root.

Preliminary
Release

TRANSMITTER ELECTRICAL CHARACTERISTICS

Parameter	Symbol	Minimum	Typical	Maximum	Unit
Baud Rate for IEEE 1394b S200	Baud Rate			250	MBd
Supply Voltage	V _{CC}	3.0	3.3	3.6	V
Current Consumption	I _{CC}			55	mA
Data Input Capacitance	C _{IN}			5	pF
Data Input Resistance (Single-ended)	R _{IN}		5		kΩ
Input Common-Mode Range	V _{IN-BIAS}	GND+0.8		V _{DD} -0.8	V
Input Voltage Swing	V _{IN-SWING}	100		1200	mV
Input Guaranteed Wake Voltage	V _{IN-WAKE}	50		100	mV
Input Guaranteed Sleep Voltage	V _{IN-SLEEP}	25		95	mV
Optical Power OFF Delay	T _{PD}	0.02		20	μs
Optical Power ON Delay	T _{PU}			5	μs
Current Consumption in Sleep Mode	I _{CC-sleep}			20	uA

TRANSMITTER PIN DESCRIPTION

Pin	Name	Symbol
1	Data Input (Negative)	TD-
2	Data Input (Positive)	TD+
3	Ground Pin	GND
4	Input DC Power Pin	V _{CC}
5	Input, -3dB Power Down (Forces output power to drop by 3dB)	Rex

TRANSMITTER SPECIAL FUNCTIONS

Function	Description
Rex	<p>The function of the Rex pin is to allow the user to adjust the optical power of the FOT by changing the drive current of the RCLED. The pin has three settings:</p> <ol style="list-style-type: none"> (1) <i>Rex is pulled to ground (set to low).</i> This is the default position and in this case the part is set to the internal default drive current of the FOT. This is the recommended setting for normal operation. (2) <i>The Rex pin is pulled high (set to rail voltage 3.3V).</i> The power of the FOT is reduced by 3 dBm. This function can be used by a system designer to perform an end of life test. (3) <i>The drive current of the device can be externally set and varied at will by placing a 15k Ohm variable resistor between Rex and ground.</i> It is not recommended to use this for standard operation, especially in applications that are sensitive to current consumption as the external variable resistor can cause higher than normal current consumption.
Sleep-State	If the FOT does not see data on its differential pins for more than 5 us, the FOT is switched into a sleep state where the optical output is switched off and the current consumption is reduced to a maximum of 20uA. For a full description, refer to the section <i>Power Management Functions</i> .

TRANSMITTER OPTICAL CHARACTERISTICS

Parameter	Symbol	Minimum	Typical	Maximum	Unit
Peak Wavelength ($T_A=-20$ to 70°C)	λ_{peak}	640	660	670	nm
Spectral Bandwidth (FWHM)	$\Delta\lambda$		23	30	nm
Average Output Power Coupled into Plastic Fiber at $T_A=-20$ to 70°C	P	-8.5		-2.0	dBm
Optical Rise Time, S200 (20%-80%)	t_r		1.5	2.0	ns
Optical Fall Time (80%-20%)	t_f		2.0	3.0	ns
Extinction Ratio	R_E	10			dB
Maximum Systematic Jitter, Light Output at TP2 ^[1]	S200			0.855	ns
Maximum Random Jitter, Light Output at TP2 ^[1]	S200			0.855	ns

Note:

1. TP2, test point 2, is the standard test point representing a point in an optical link located 50cm into the fiber from the transmitter side. This is a standard point of reference quoted in the IEEE 1394b and IDB-1394 standards.

RECEIVER ELECTRICAL CHARACTERISTICS

Parameter	Minimum	Typical	Maximum	Unit
V _{cc}	3.0	3.3	3.6	V
I _{cc} (Normal Operation)			45	mA
I _{cc} - Sleep State			20	uA
Output Impedance Between D and \bar{D}		100		Ω
Offset Voltage for LVDS		1.2		V
Differential Output Voltage (LVDS)	300		400	mV
SD (Signal Detect) On Output Voltage	2.4			V
SD (Signal Detect) Off Output Voltage	0		0.4	V
SD (Signal Detect) Assert Level	-28	-27	-24	dBm
SD (Signal Detect) Deassert Level	-32	-29	-24.5	dBm
SD (Signal Detect) Assert Time	0.6	5	100	us
SD (Signal Detect) Deassert Time	0.6	5	100	us
High Level Output Voltage			1.475	V
Low Level Output Voltage	0.925			V
Maximum Systematic Jitter, Electrical Output at TP4 (S200) ^[1]			1200	ps p-p
Maximum Random Jitter, Electrical Output at TP4 (S200) ^[1]			700	ps p-p

Note:

1. TP4, test point 4, is the electrical interface of the receiver which corresponds to the standard as set in IEEE 1394b and IDB-1394 standards.

RECEIVER PIN DESCRIPTION

Pin	Name	Symbol
1	Input DC Power Pin	V _{cc}
2	Ground Pin	GND
3	Output Signal Detect	SD
4	Data Input (Negative)	RD-
5	Data Input (Positive)	RD+

RECEIVER SPECIAL FUNCTIONS

Function	Description
Sleep Function for Power Saving Applications	If the Rx FOT does not see optical data on its PD (photo detector) for more than 5 us, the FOT is switched into a sleep state where the main IC is switched off and the current consumption is reduced to a maximum of 20uA. At this point there is no electrical output from the device. For a full description of this function refer to the section <i>Power Management Functions</i> .
SD (Signal Detect)	This is an LVCMOS-type signal with output high of 2.4V and output low of 0.4V.

RECEIVER OPTICAL CHARACTERISTICS

Parameter	Symbol	Minimum	Typical	Maximum	Unit
Receivable Power		-24		-2	dBm
Rise/Fall Time (10%-90%)				2	ns

GENERAL TEST APPLICATION CIRCUIT

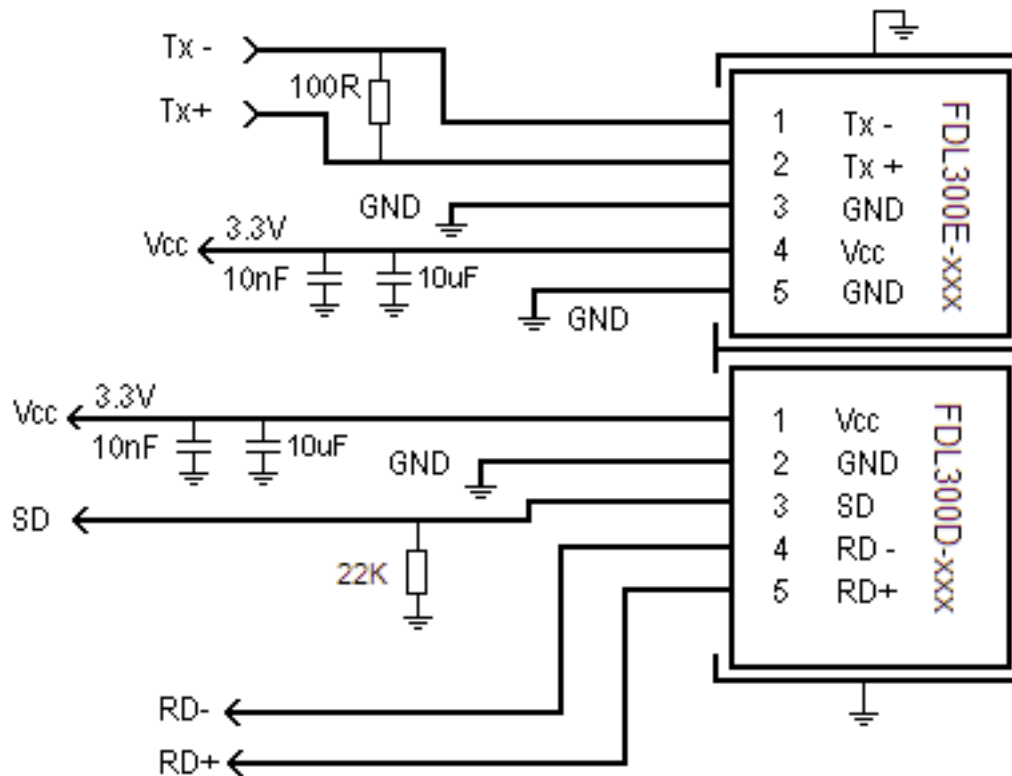

Figure 1. General application circuit.

Preliminary
Release

IEEE 1394 APPLICATION CIRCUIT

Figure 2 illustrates the correct configuration for the interface between the Texas Instruments 1394b PHY (part number TSB41BA3B) and the Firecomms Tx and Rx FOT pair, part numbers FDL300E and FDL300D.

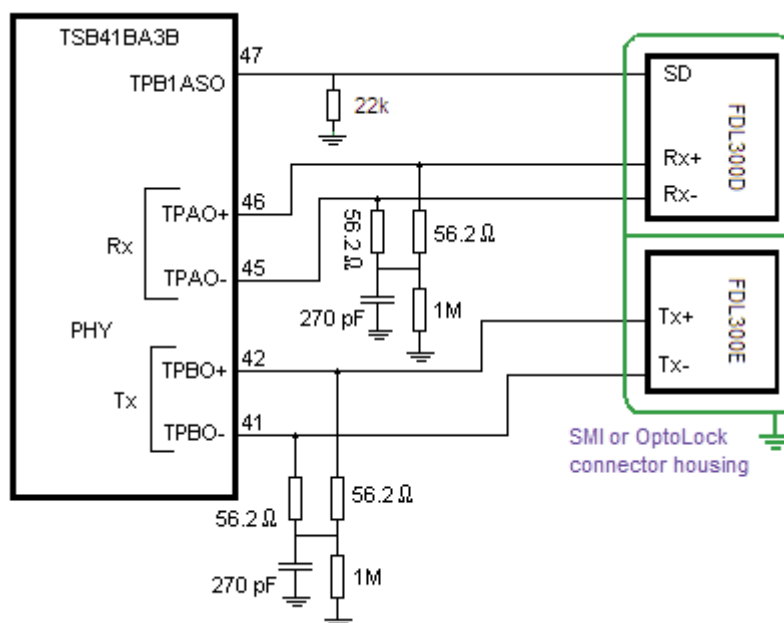

Figure 2. Circuit schematic for interface between a T1 1394b PHY and Firecomms FOTs.

Note on Reduced Power Consumption

Firecomms FOTs do not need a level-shifting circuit between the PHY and FOT as the differential I/O swings have been matched. The result of this PHY and FOT I/O matching is the elimination of power consumption by the level shifting circuit. Previously, FOT designs required a level shifting network (LVDS to LVPECL) which consumed approximately 33 mA from the power rail (V_{CC}) for each I/O. In that design, power consumption continued irrespective of the PHY IC and even if the FOTs were powered down or in sleep states. With the Firecomms FOT solution, this power consumption has been eliminated.

In the circuit shown in Figure 2, once the PHY and FOTs enter a sleep state the power consumption is reduced to the data sheet values for PHY and FDL300 sleep states. There is no residual power consumption from the interface circuit. Similarly, if the PHY and the FOTS experience a hard power-down, current consumption goes to zero.

MECHANICAL DATA

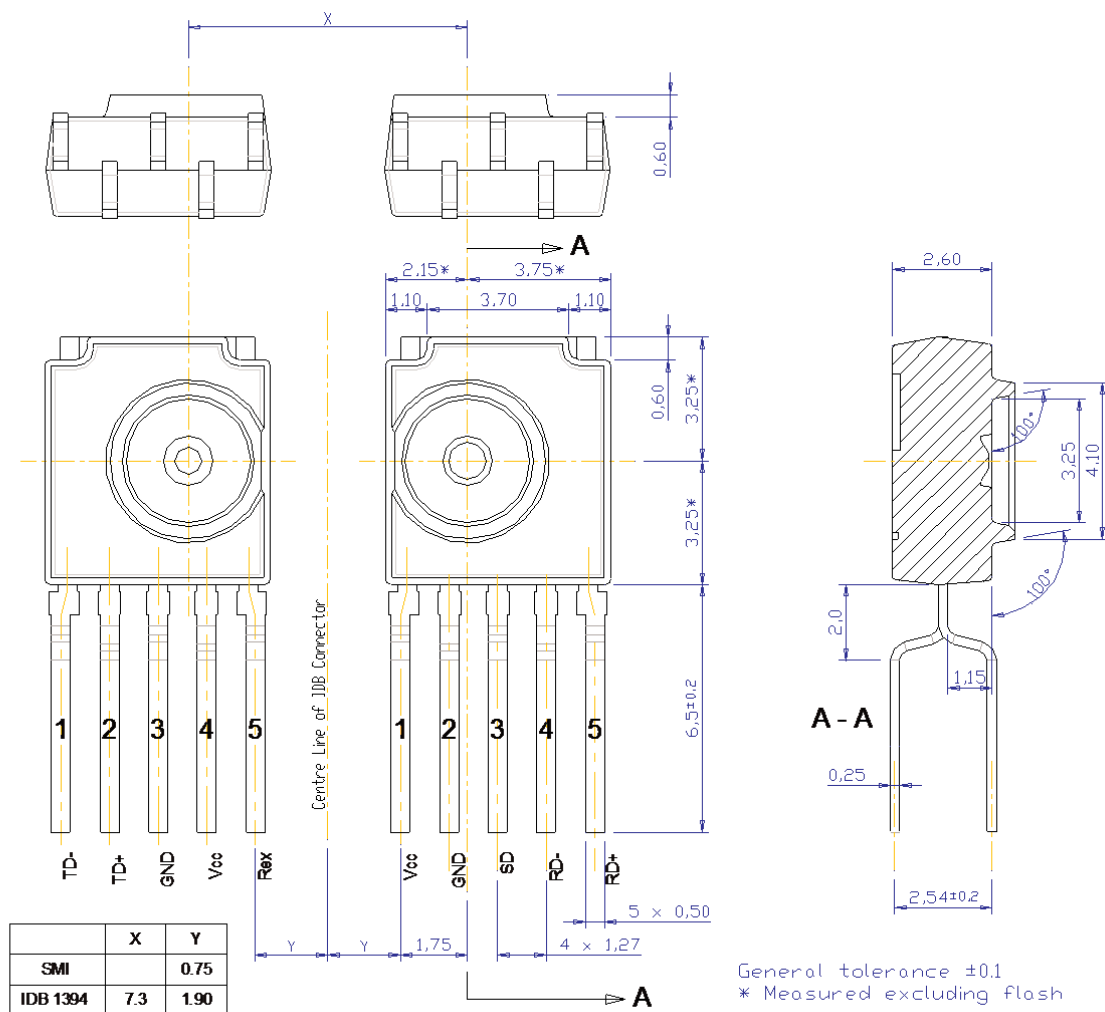

FDL300E-120

FDL300D-120

Figure 3.

Mechanical data for the Firecomms integrated transmitter FDL300E and integrated receiver FDL300D.

Notes:

- A. The metal projections at the top corners of the package are internally connected and should not come into electrical contact with any metal surface, ground plane or circuit board.
- B. The alignment ring (diameter 3.25/4.10) is the primary mechanical reference for alignment of the fiber.

PCB LAYOUT FOR SMI CONNECTOR (CONSUMER 1394 APPLICATIONS)

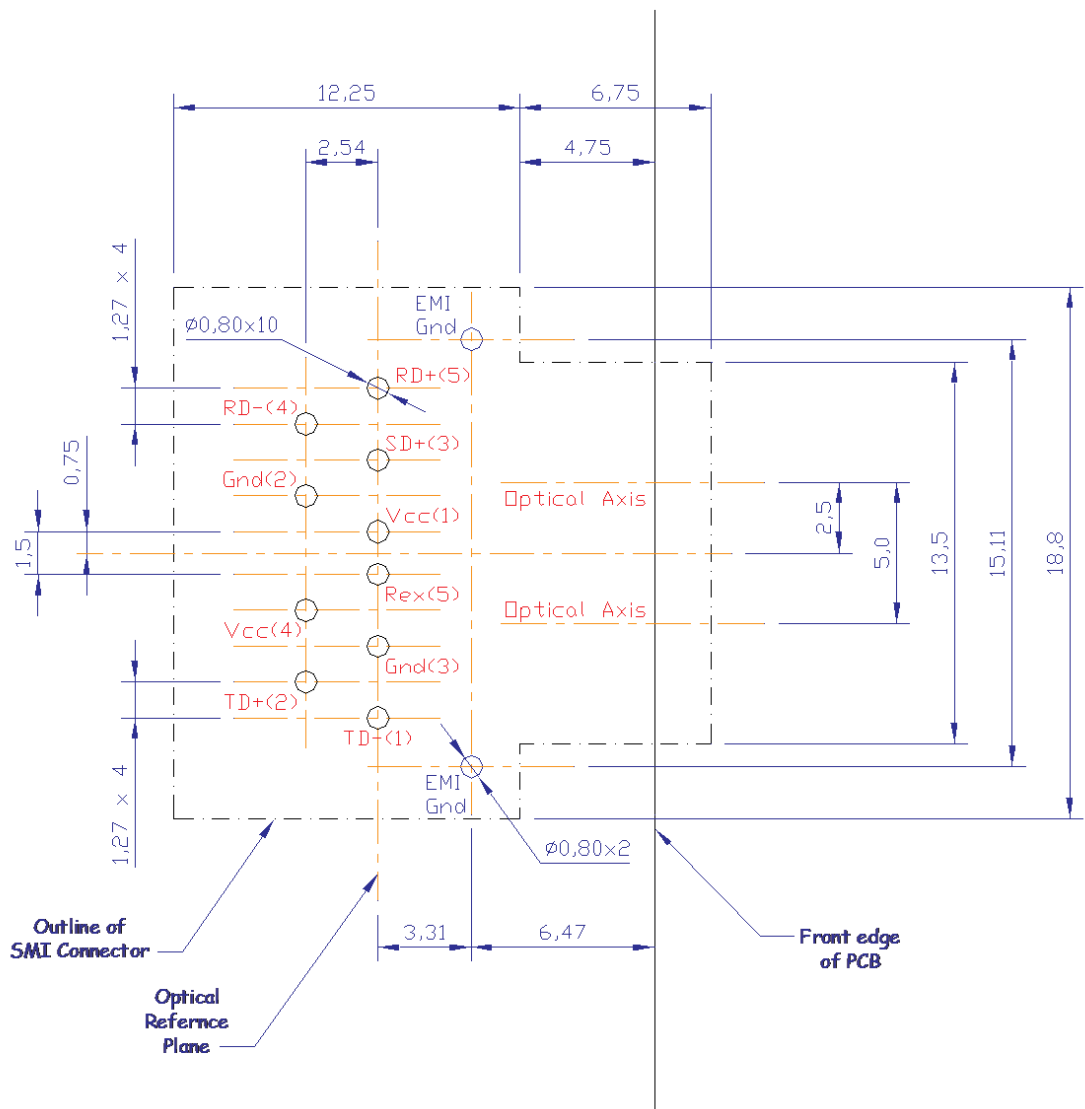

Figure 4.

PCB footprint for SMI connector housing containing Firecomms FDL300E integrated transmitter and FDL300D high sensitivity integrated receiver with pre-formed leads. Firecomms FOTs with straight leads also are available.

POWER MANAGEMENT FUNCTIONS

There are four port states available when Firecomms FDL FOTs are configured for IEEE 1394 operation. These states are described in the Port States table.

Each FOT can be in one of three states: On, Sleep, or Off. Based on these states, the port states can be implemented as follows:

- Full Power: Both Tx and Rx are fully powered up
- Low Power: Tx and Rx are in a sleep state
- Ultra-Low Power: Tx is fully powered down ($V_{cc} = 0\text{ V}$) and Rx is in a sleep state
- Off: Both Tx and Rx are fully powered down ($V_{cc} = 0\text{ V}$)

PORT STATES					
Port State	Tx	Tx Current Consumption (Maximum)	Rx	Rx Current Consumption (Maximum)	Tx+Rx Total Maximum Current
Full Power	On	55 mA	On	45 mA	100 mA
Low Power	Sleep	20 μA	Sleep	20 μA	40 μA
Ultra-Low Power	Off	0 A	Sleep	20 μA	20 μA
Off	Off	0 A	Off	0 A	0 A

The FDL300E/D FOT pair supports the IEEE 1394b PMD wake up on LAN specification (ref: TS2004024). Low power mode is triggered by the differential voltage signal swing at the input to the Tx dropping below 50 mV. In this case, the Tx switches to a sleep power state consuming a maximum of 20 μA . Ultra-low power mode is triggered by a hard-disable of the Tx, which is when the power to the Tx is switched off ($V_{cc} = 0\text{ V}$). In both low power and ultra-low power cases, the Rx responds to the Tx powering down. With the Tx powered off, the Rx signal detect (SD) drops low and remains low for more than 50 ms at which point the Rx also switches into sleep mode (consuming a maximum of 20 μA). The last power mode is referred to as power off. This occurs when the DC power (V_{cc}) to both the Tx and Rx is hard-disabled (switched off). The wake up is described by the circuit diagrams shown in Figures 5 through 7.

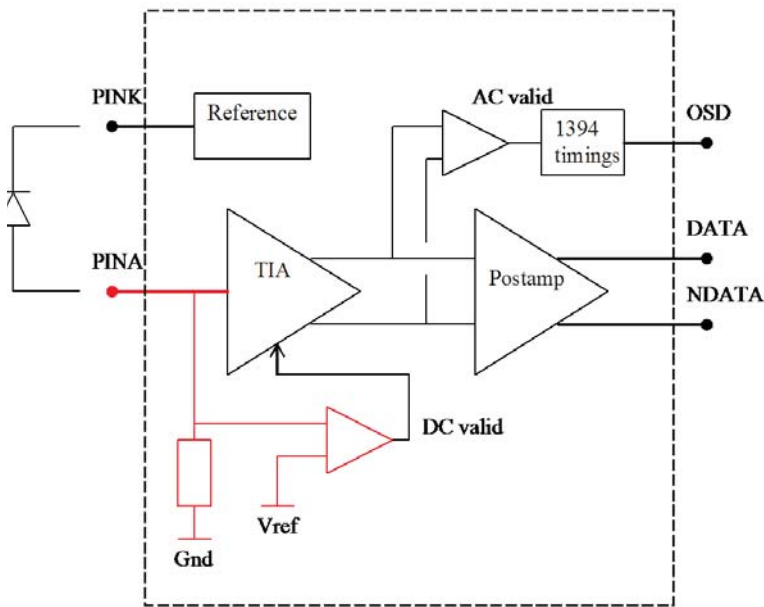

Figure 5.
In low power or ultra-low power state, the receiver uses a maximum of 20 uA to monitor optical activity. The PIN diode and a voltage reference monitor for the presence of optical data.

Figure 6.
On receiving optical power, the Rx will power up all sections of the IC, except the output data section, and will check to see if the optical signal is a valid data signal.

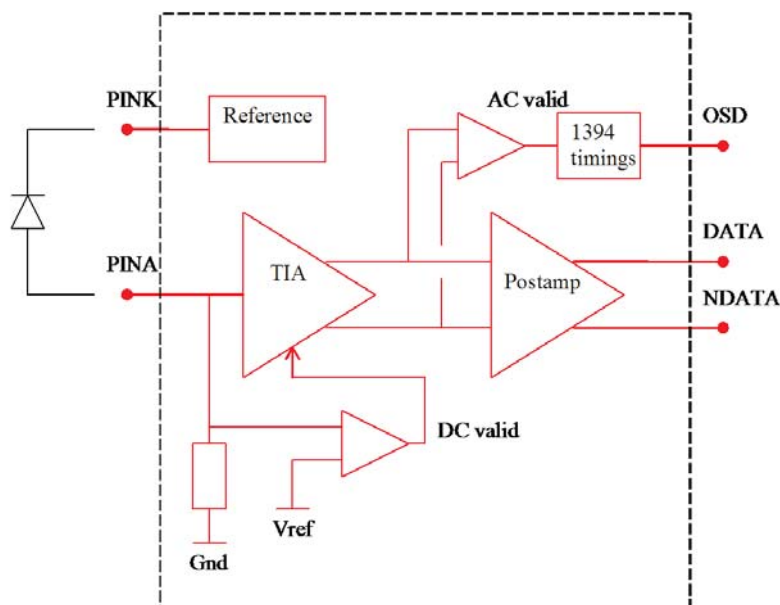
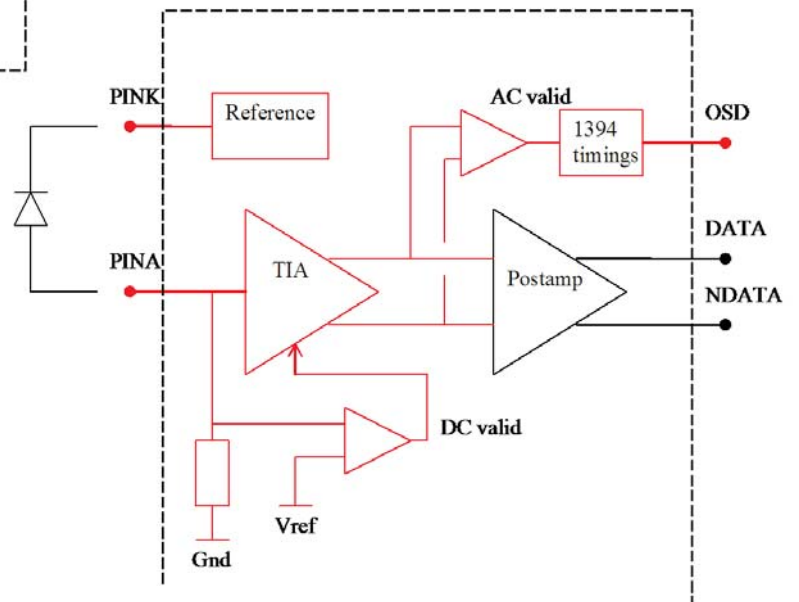

Figure 7.
Once valid data has been received for 5 us, the complete IC powers up and data is available from the Data+ and Data- output pins.

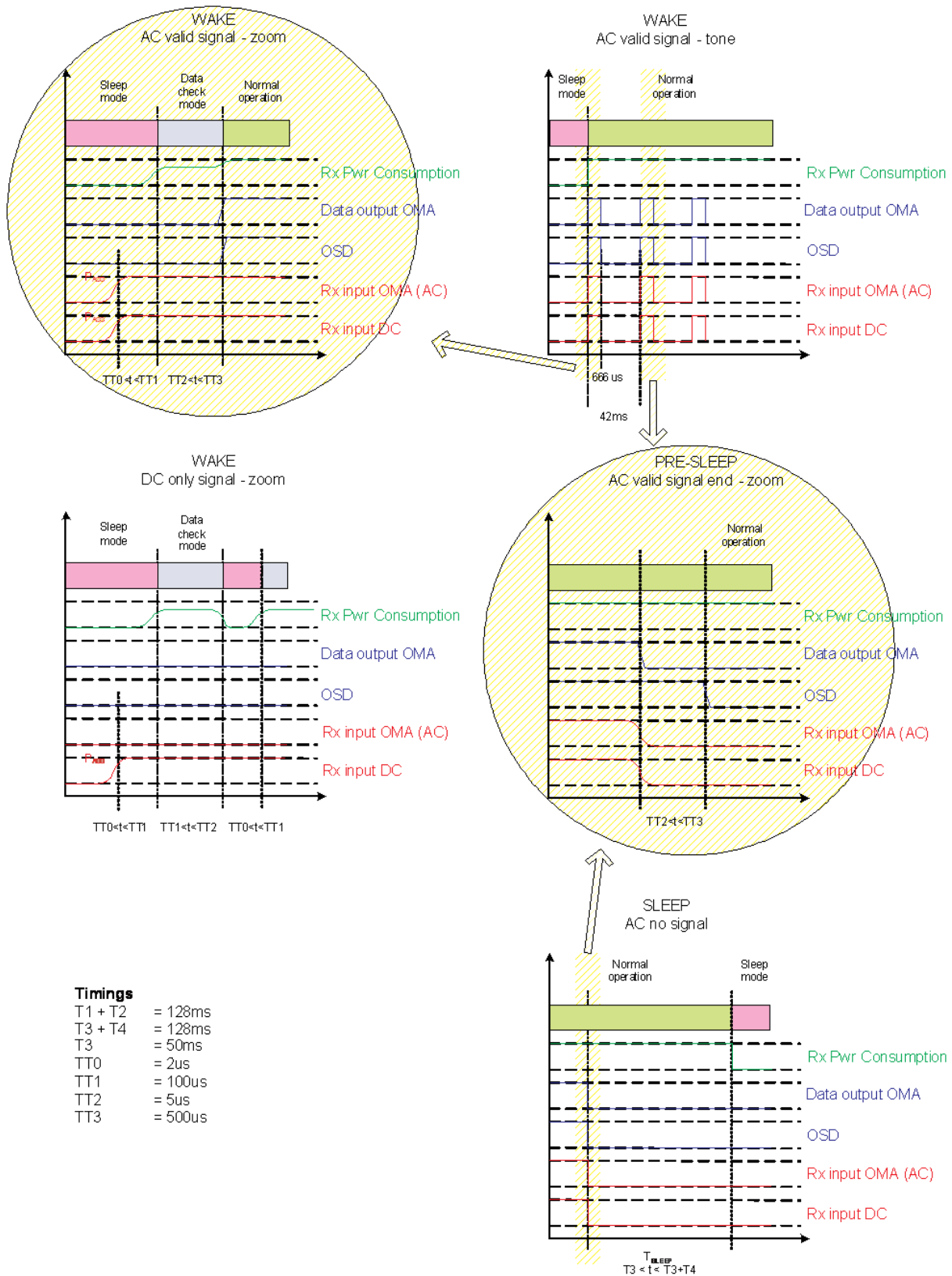

Figure 8.
Timing diagrams for PMD wake-up on LAN.

EVALUATION BOARDS

Firecomms offers a Transceiver Developer Kit that consists of two evaluation boards for the Firecomms IEEE 1394 FOT. Each evaluation board includes one 10m cable (Eska Mega 0.3NA) completely assembled with connector plugs, and is fitted with a choice of a SMI connector or an IDB connector that contains the FDL300E/FDL300D pair. SMA-type connectors are used to interface Data I/O, SD, and Rex.

PACKING INFORMATION

Components are packed in PVC anti-static tubes in moisture barrier bags. Bags should be opened only in static-controlled locations, and standard procedures should be followed for handling moisture sensitive components.

PACKING INFORMATION

Components per Tube	50
Tube Length	316 mm
Tube Height	5 mm
Tube Depth	20 mm
Tubes per Bag	20
Bags per Inner Carton	1
Inner Carton Length	450 mm
Inner Carton Height	100 mm
Inner Carton Depth	120 mm
Weight per Inner Carton, Complete	0.7 Kg
Components per Inner Carton	1000
Inner Cartons per Outer Carton	4
Outer Carton Length	465 mm
Outer Carton Height	260 mm
Outer Carton Depth	220 mm
Weight per Outer Carton, Complete	3.2 Kg
Components per Outer Carton	4000

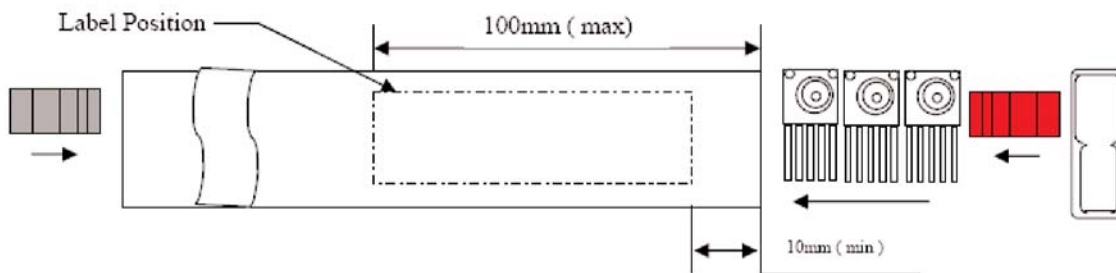

Figure 9. FDL300 Rx components inside tube.

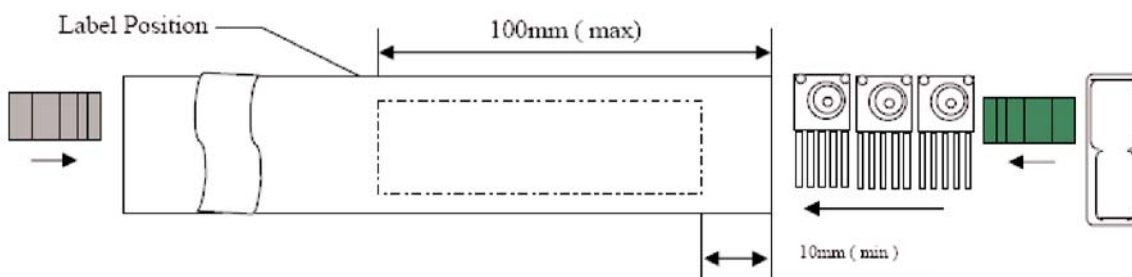

Figure 10. FDL300 Tx components inside tube.

ORDERING INFORMATION

Part Number	Name	Description
FDL300E-120	Tx FOT	Transmitter, pre-formed leads (see Figure 3)
FDL300D-120	Rx FOT	Receiver, pre-formed leads (see Figure 3)
FDL300K-120	Kit	Includes Tx FOT (FDL300E-120) and Rx FOT (FDL300D-120)

Firecomms Ltd.
 2200 Airport Business Park
 Cork, Ireland
 Ph +353 (21) 4547100 Fax +353 (21) 4322657
www.firecomms.com

Copyright (c) 2007 Firecomms Ltd.
 FDL300E/FDL300D (Preliminary) Revision P13
 Firecomms assumes no responsibility for inaccuracies or omissions in the information contained in this document. Specifications are subject to change without notice.
 No patent rights are granted to any of the circuits described herein.