

MPS-350

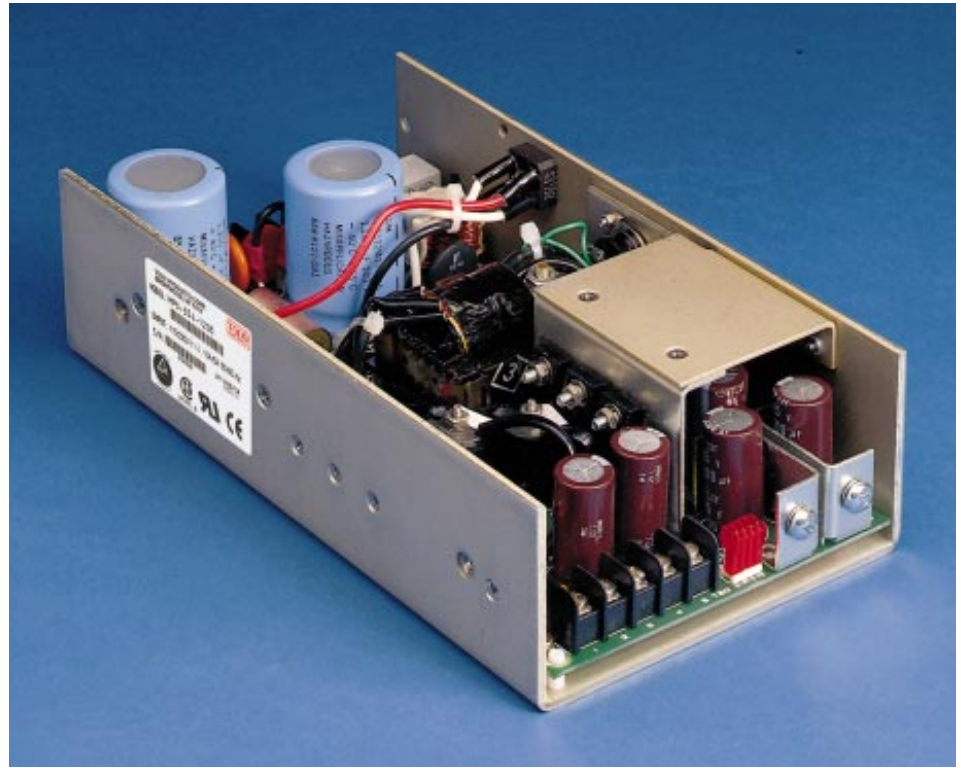

STANDARD MPS SERIES

MODEL	PWR	OUTPUT #1	OUTPUT #2	OUTPUT #3	OUTPUT #4
MPS-353-0512	350	+5V @ 50A	+12V @ 8/12A pk	-12V @ 4A	
MPS-354-1205	350	+5V @ 50A	+12V @ 8/12A pk	-12V @ 4A	-5.2V @ 2A
MPS-354-1224	350	+5V @ 50A	+12V @ 8/12A pk	-12V @ 4A	+24V @ 1.5A

Featuring:

- N +1 redundancy and parallel power sharing
- “Zero wire” slope program current sharing for redundancy
- Over 3 watts/in³ power density
- 80% overall efficiency
- Meets international safety agency requirements
- All auxiliary outputs regulated $\pm 1\%$
- High peak currents for motor starting
- System air or self-cooling options
- AC automatic line selection option
- Available in 48 Vdc input

Condor’s MPS-350 multiple output switching power supplies are the ideal solutions for critical applications such as communications equipment and industrial controls. These often require parallel power sharing for expandable systems or redundant power supplies for “fail-safe” reliability. With Condor’s innovative “zero wire” power sharing technique, these switchers will provide a highly reliable power sharing system.

The MPS Series utilizes proprietary technology that does not require extra connections to achieve redundancy or to share power. This technology ensures that all of the working supplies stay “on” and deliver current to the load, allowing no glitches. The load sees consistent regulated voltage before, during, and after a power supply failure. With our MPS Series, the user enjoys highly reliable power sharing, glitch-free performance, and minimum complexity.

You can build any number of these switchers into your system to allow paralleling for additional power or N +1 redundancy. The switcher can also be used alone as the basic building block power supply for future system expansion.

Housed in a low-profile, open frame configuration measuring only 9” x 5” x 2.5”, the MPS delivers 350 watts of power with a main output of 5 Volts at 50 Amps. The unit is designed to be cooled with system air or through an optional fan/cover assembly.

Other features include: Overvoltage Protection, Overtemperature Protection, Soft Start, Remote Inhibit, Remote Sense, Overcurrent Protection, DC Power Good and Auto-Ranging. Fan/covers are also available.

If your design calls for power sharing, redundancy, or expandability, check out the important features and specifications of this Condor switcher for a truly reliable, optimum power sharing system.

MPS-350
3.4 lbs - 1.5 kgs

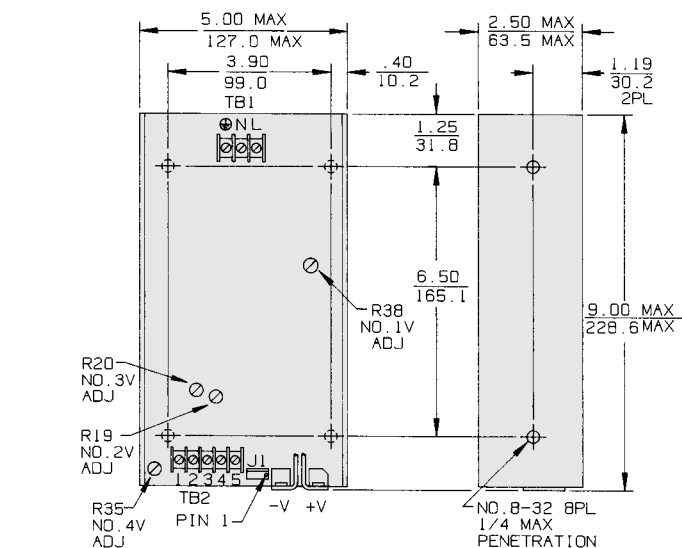

Dimensions: Inches
Millimeters

SPECIFICATIONS: ALL MODELS

INPUT

AC Input: 90-132 Vac/180-264 Vac, 47 to 63 Hz. User selectable. See option "A" for automatic line selection. Internally fused for 10 A.

Inrush: Cold start AC current is less than 10 A at 115 Vac and 18 A at 230 Vac. For MTX models, 10 A at 115 Vac and 20 A at 230 Vac. Limited by thermistor.

Holdup Time: 16 ms minimum after removal of power, at nominal line, full load.

Efficiency: 80% typical.

Brownout Protection: Holds regulation to 85 Vac or 170 Vac.

OUTPUT

Adjustability: All outputs user adjustable $\pm 5\%$ minimum.

Line & Load Reg (Output #1): $\pm 3\%$ over AC input range and 10 to 100% load change (preprogrammed slope). 10% minimum load required.

Line & Load Reg (Other outputs): $\pm 1\%$ over AC input range and 0 to 100% load change. No minimum load required.

Ripple & Noise: Less than 1% p-p or 100 mV, whichever is greater.

Remote Sense (Output #1): Compensates for 250 mV total line drop. Open sense lead protection. (See Redundancy, below.)

Temperature Coefficient: 0.02% per degree C.

Stability: 0.1% over 8 hours after 30 minutes warm-up.

Transient Response: Output voltage returns to within 1% in less than 500 μ s for a 50% load change. Peak transient does not exceed 5%.

Overload Protection: All outputs are protected against overload and short circuit. Automatic recovery upon removal of fault.

Overvoltage Protection (Output #1): Protects load against power supply induced overvoltage. Trip point is factory set so that output voltage cannot exceed 136% of nominal.

Peak Output Current: Dual current ratings define continuous and peak currents. The peak current shown can be delivered for a maximum period of 30 seconds.

Remote Inhibit: Contact closure to the negative sense line drops output power to nominal zero.

Redundancy: External OR-ing diodes and slope program current sharing on output #1 provide "N+1" capability. Remote sense (+S) compensates for additional 0.6 V diode voltage drop. Current sharing remains within 10% of the unit's full output current rating.

Reverse Voltage: Protected against reverse voltage up to supply current rating.

ENVIRONMENTAL

Thermal Protection: Shuts down power supply if overheated. Automatic recovery.

Temperature Range: 0° to 50°C at full ratings.

Safety Agencies: Most models are approved to UL1950; CSA 22.2 #234; IEC 950 and TÜV EN60950, Class 1 SELV, CE 72/23/EEC/93/68EEC (low voltage directive).

Conducted RFI: Meets FCC Part 15, Subpart J, Class A; EN55022 Class B; CISPR 22 Class B.

Output Isolation: Isolated from ground 50 Vdc.

Cooling: 30 CFM required to achieve full ratings.

OPTIONS:

Option "A", AC Auto-Range: Automatically selects proper AC line voltage range to enable power operation at either 115 or 230 Vac without user intervention.

Option "C", Cover: Limits contact with power supply interior.

MPS-350 with option F
3.9 lbs - 1.8 kgs

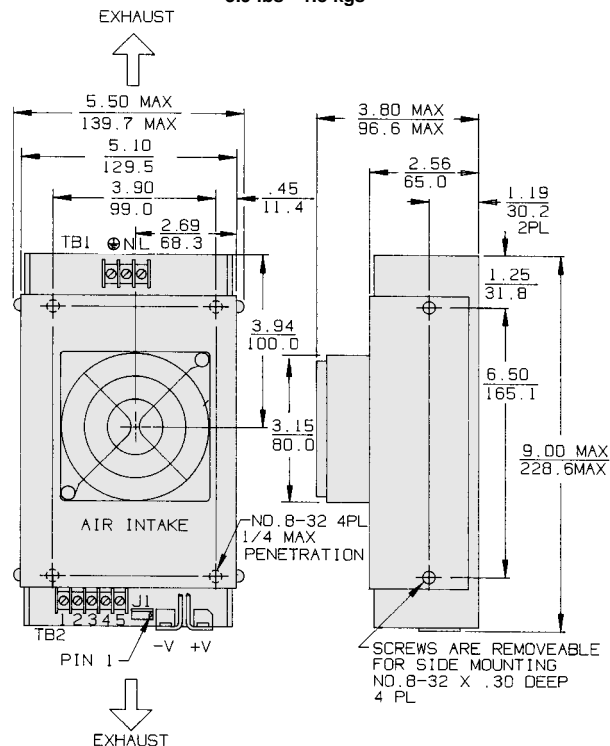

Option "F", Fan/Cover Assembly: Cover with integral ball-bearing fan provides proper cooling to achieve full ratings at 50°C ambient temperature.

Option "G", DC Power Good: Provides a TTL "1" open collector when output #1 is above 4.6 V nominal. Not available if option "P" is selected.

Option "P", AC Power Fail: Provides TTL "0" 5 ms before output voltage goes out of regulation band upon loss of ac power. VMEbus compatible, provides 48 mA sink current capability. Not available if option "G" is selected.

Option "V", Fan/Cover Assembly: Low profile, end venting cover with integral ball-bearing fan.

Consult factory for other available options.

AC INPUT

FUNCTION	115 VAC	230 VAC	CONNECTOR
Input Select	Short	Open	0.187 Male Fastons
TB1- (L)	Line	Line 1	Barrier strip
TB1- (N)	Neutral	Line 2	#6-32 screws
TB1- (G)	Safety Ground	Safety Ground	3/8" centers

DC OUTPUT

FUNCTION	LOCATION	NOTES	CONNECTOR
Output #1	Terminal marked +V	Main Output	Bus bars
	Terminal marked COM	Rtn (Common)	#10-32 screws
Output #2	TB2-3		Barrier strip #6-32 screws 3/8" centers
	TB2-4	Rtn (Common)	
Output #3	TB2-5		Barrier strip #6-32 screws 3/8" centers
	TB2-4	Rtn (Common)	
Output #4* (If provided)	TB2-1	(+)	Barrier strip #6-32 screws 3/8" centers
	TB2-2	(-)	

*Rtn connected to common only if output is polarized in product selection chart

STATUS AND CONTROL

FUNCTION	LOCATION	NOTES	CONNECTOR
Remote Sense	J1-1(+S)	Output #1 Sense	AMP MTA type #640456-4 pin header (locking)
	J1-2 (-S)	Output #1 Sense Rtn	
AC Power Fail or DC Power Good*	J1-3 (PF)	Reference to J1-2	AMP MTA type #640456-4 pin header (locking)
Inhibit	J1-4 (IH)	Short to J1-2	

*Optional function