

The RF Line Microwave Power Transistor

... designed for CW and long pulsed common base amplifier applications, such as JTIDS and Mode S, in the 0.96 to 1.215 GHz frequency range at high overall duty cycles.

- Guaranteed Performance @ 1.215 GHz, 28 Vdc
Output Power = 5.0 Watts CW
Minimum Gain = 8.5 dB, 10.3 dB (Typ)
- RF Performance Curves given for 28 Vdc and 36 Vdc Operation
- 100% Tested for Load Mismatch at All Phase Angles with 10:1 VSWR
- Hermetically Sealed Industry Standard Package
- Silicon Nitride Passivated
- Gold Metallized, Emitter Ballasted for Long Life and Resistance to Metal Migration
- Internal Input Matching for Broadband Operation

MRF10005

**5.0 W, 960–1215 MHz
MICROWAVE POWER
TRANSISTOR
NPN SILICON**

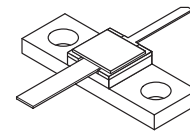

CASE 336E-02, STYLE 1

MAXIMUM RATINGS

Rating	Symbol	Value	Unit
Collector–Emitter Voltage	V_{CES}	55	Vdc
Collector–Base Voltage	V_{CBO}	55	Vdc
Emitter–Base Voltage	V_{EBO}	3.5	Vdc
Collector Current — Continuous (1)	I_C	1.25	mAdc
Total Device Dissipation @ $T_A = 25^\circ\text{C}$ (1) Derate above 25°C	P_D	25 143	Watt mW/ $^\circ\text{C}$
Storage Temperature Range	T_{stg}	-65 to +200	$^\circ\text{C}$
Junction Temperature	T_J	200	$^\circ\text{C}$

THERMAL CHARACTERISTICS

Characteristic	Symbol	Max	Unit
Thermal Resistance, Junction to Case (2)	$R_{\theta JC}$	7.0	$^\circ\text{C}/\text{W}$

NOTES:

1. These devices are designed for RF operation. The total device dissipation rating applies only when the devices are operated as RF amplifiers.
2. Thermal Resistance is determined under specified RF operating conditions by infrared measurement techniques.

ELECTRICAL CHARACTERISTICS ($T_C = 25^\circ\text{C}$ unless otherwise noted.)

Characteristic	Symbol	Min	Typ	Max	Unit
OFF CHARACTERISTICS					
Collector–Emitter Breakdown Voltage ($I_C = 25\text{ mAdc}$, $V_{BE} = 0$)	$V_{(BR)CES}$	55	—	—	Vdc
Collector–Base Breakdown Voltage ($I_C = 25\text{ mAdc}$, $I_E = 0$)	$V_{(BR)CBO}$	55	—	—	Vdc
Emitter–Base Breakdown Voltage ($I_E = 0.5\text{ mAdc}$, $I_C = 0$)	$V_{(BR)EBO}$	3.5	—	—	Vdc
Collector Cutoff Current ($V_{CB} = 28\text{ Vdc}$, $I_E = 0$)	I_{CBO}	—	—	1.0	mAdc

ON CHARACTERISTICS

DC Current Gain ($I_C = 500\text{ mAdc}$, $V_{CE} = 5.0\text{ Vdc}$)	h_{FE}	20	—	100	—
---	----------	----	---	-----	---

DYNAMIC CHARACTERISTICS

Output Capacitance ($V_{CB} = 28\text{ Vdc}$, $I_E = 0$, $f = 1.0\text{ MHz}$)	C_{ob}	—	7.0	10	pF
--	----------	---	-----	----	----

FUNCTIONAL TESTS

Common–Base Amplifier Power Gain ($V_{CC} = 28\text{ Vdc}$, $P_{out} = 5.0\text{ W}$, $f = 1215\text{ MHz}$)	G_{PB}	8.5	10.3	—	dB
Collector Efficiency ($V_{CC} = 28\text{ Vdc}$, $P_{out} = 5.0\text{ W}$, $f = 1215\text{ MHz}$)	η	45	55	—	%
Load Mismatch ($V_{CC} = 28\text{ Vdc}$, $P_{out} = 5.0\text{ W}$, $f = 1215\text{ MHz}$, $VSWR = 10:1$ All Phase Angles)	ψ	No Degradation in Output Power			

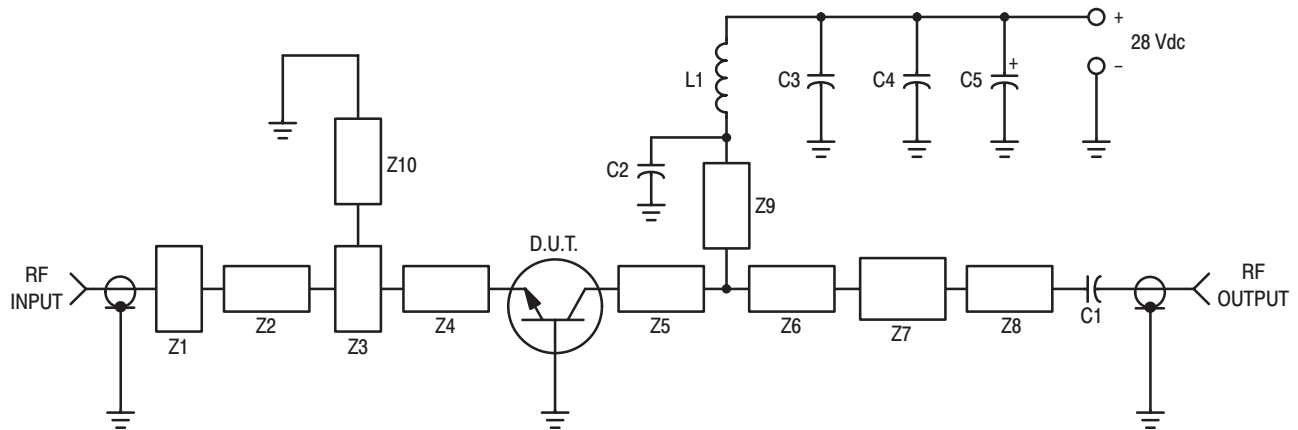

C1, C2, C3 — 220 pF 100 mil Chip Capacitor
 C4 — 0.1 μF
 C5 — 47 $\mu\text{F}/50\text{ V}$ Electrolytic
 L1 — 3 turn #18 AWG, 1/8" ID, 0.18" Long

Z1–Z10 — Microstrip, see details below
 Board Material — 0.030" Glass Teflon,
 2.0 oz. Copper, $\epsilon_r = 2.55$

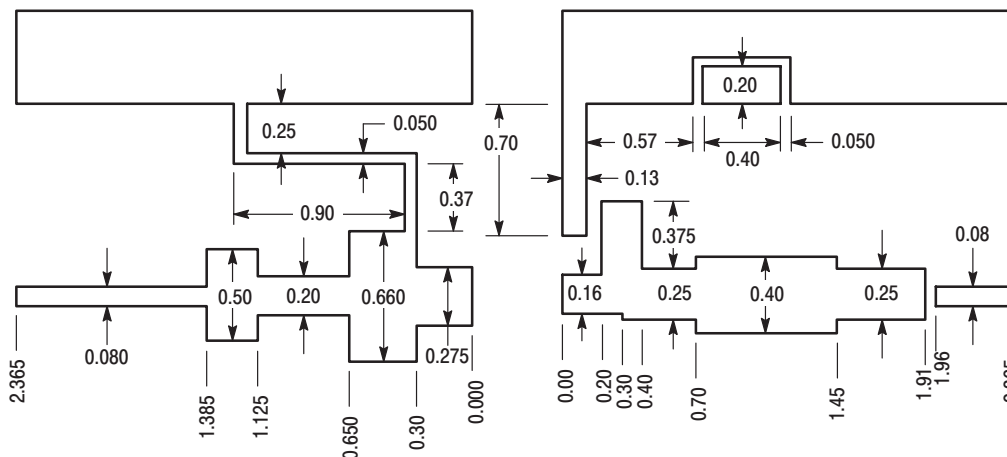

Figure 1. Test Circuit

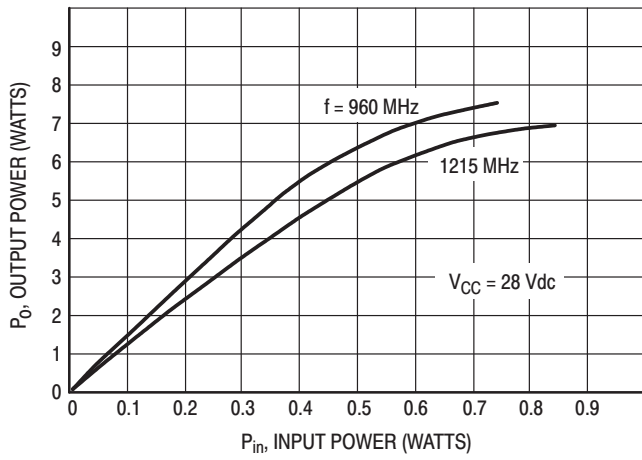

Figure 2. Output Power versus Input Power

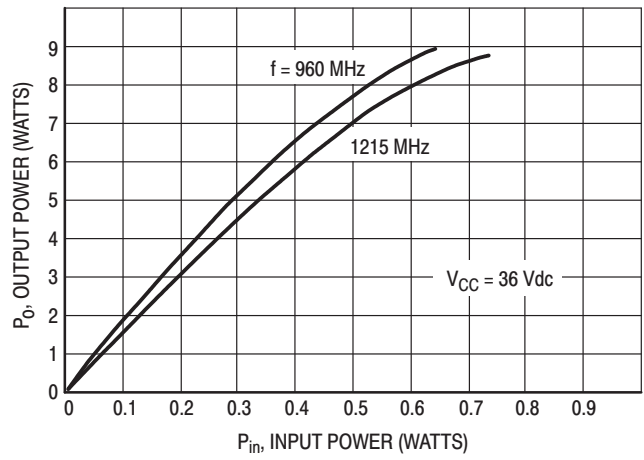

Figure 3. Output Power versus Input Power

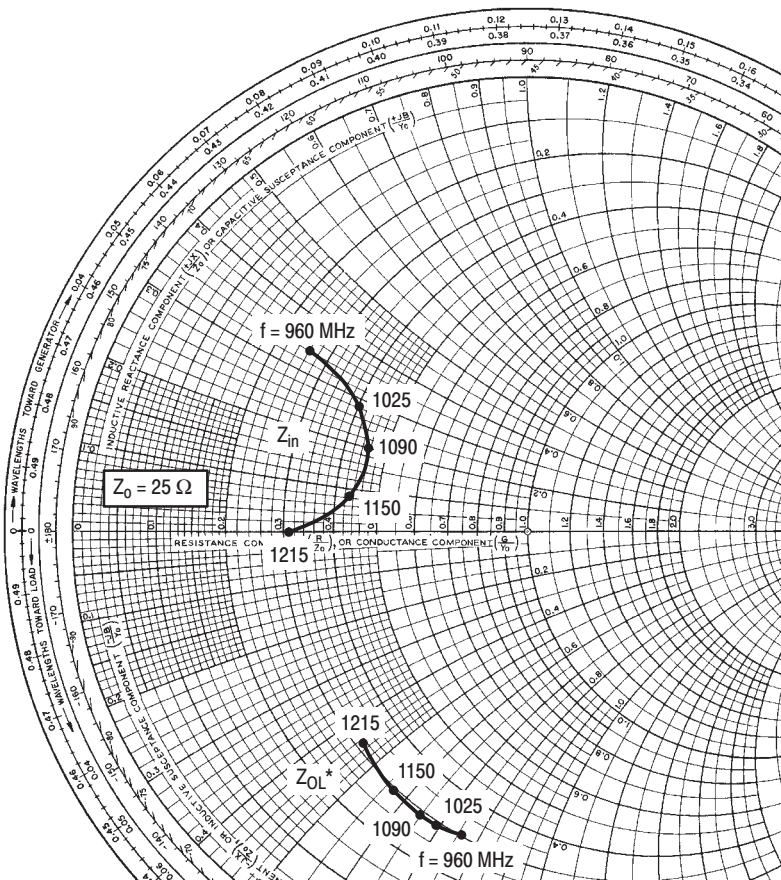

Figure 4. Series Equivalent Input/Output Impedances

$P_{out} = 5\text{ W}, V_{CC} = 28\text{ V}$

f MHz	Z_{in} OHMS	Z_{OL}^* OHMS
960	$6.5 + j8.5$	$7.4 - j18.9$
1025	$10.0 + j7.0$	$7.2 - j17.4$
1090	$11.2 + j4.9$	$7.1 - j16.3$
1150	$10.8 + j2.0$	$7.15 - j14.3$
1215	$7.8 + j0.0$	$7.8 - j11.2$

Z_{OL}^* = Conjugate of the optimum load impedance into which the device output operates at a given output power, voltage and frequency.

PACKAGE DIMENSIONS

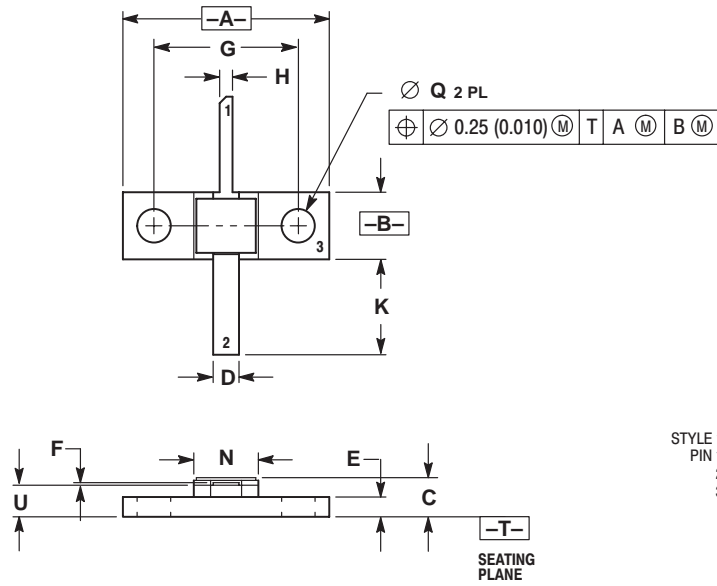

NOTES:
 1. DIMENSIONING AND TOLERANCING PER ANSI Y14.5M, 1982.
 2. CONTROLLING DIMENSION: INCH.

DIM	INCHES		MILLIMETERS	
	MIN	MAX	MIN	MAX
A	0.790	0.810	20.07	20.57
B	0.253	0.267	6.43	6.78
C	0.144	0.160	3.66	4.06
D	0.093	0.107	2.37	2.71
E	0.074	0.080	1.88	2.03
F	0.002	0.006	0.06	0.15
G	0.560 BSC		14.22 BSC	
H	0.043	0.057	1.10	1.44
K	0.346	0.394	8.79	10.10
N	0.243	0.257	6.18	6.52
Q	0.125	0.135	3.18	3.42
U	0.117	0.128	2.98	3.25

STYLE 1:
 PIN 1. COLLECTOR
 2. EMITTER
 3. BASE

**CASE 336E-02
 ISSUE B**

Specifications subject to change without notice.

- North America: Tel. (800) 366-2266, Fax (800) 618-8883
- Asia/Pacific: Tel.+81-44-844-8296, Fax +81-44-844-8298
- Europe: Tel. +44 (1344) 869 595, Fax+44 (1344) 300 020

Visit www.macom.com for additional data sheets and product information.

REV 6

tyco / Electronics

MACOM